

Table of contents

1	Safety information	1
1.1	General safety instructions	1
1.2	Safety when making the electrical connection	1
1.3	Avoid connection errors	2
1.4	Safe function and EMC of the drive system	2
1.5	Applied standards	2
2	Power connection	2
2.1	Motor connection with star connection	3
2.2	Motor connection with delta connection	3
2.3	Motor connection with star/delta connection	4
3	Options	4
3.1	Temperature sensor	4
3.2	Connection for external fan motor	5
3.3	Brake connection	5
3.3.1	Connection without rectifier	5
3.3.2	Connection with rectifier	6
3.4	Connection for encoder	8
3.4.1	Incremental encoder HTL/TTL	8
3.4.2	Encoder SSI digital	8
3.4.3	Additional options	8

1 Safety information

1.1 General safety instructions

 **WARNING!**

When connecting and operating the motors considerable hazards to the life and health of persons may occur!

- ▶ When connecting the motor observe the following safety instructions, the operating instructions for the motor and applicable national, local and system-specific regulations.
-

1.2 Safety when making the electrical connection

 **WARNING!**

Electrical shock by touching live unpainted parts of the motor!

- ▶ The electrical connection of the motor may only be carried out by a qualified electrician.
 - ▶ Before connecting the motor, switch the relevant system or machine to zero potential with the main switch and protect the main switch against being turned on again!
 - ▶ Close the entire connector housing before turning on the motor.
-

1.3 Avoid connection errors

NOTICE

Electrical connection errors can cause damage to the motor and its components.

- ▶ Make sure that the cables and connectors to be connected meet this motor connection plan.
- ▶ Carefully note the information on the motor name plate and this motor connection plan. For questions please contact STÖBER Service department.

1.4 Safe function and EMC of the drive system

NOTICE

If connection cables or a drive controller that are not designed for the motor are used to make the electrical connection for the motor, this may result in damage to the motor or that compliance with the legal requirements for EMC is no longer provided and claims under the warranty will be null and void.

- ▶ You should use connection cables and a drive controller specifically designed for your motor from the STÖBER product range.

1.5 Applied standards

Asynchronous motors meet the requirements of the standard VDE 0530 / DIN EN 60034.

Colors are coded as per IEC 60757 and are only relevant for the internal motor connection strands

2 Power connection

NOTICE

The motor can be damaged by electrical connection errors!

- ▶ Check before making the connection whether the connection voltage and configuration of the motor (see name plate) match the supply voltage or the selected connection diagram.

To connect the motor:

1. Open the cover of the connector box.
2. Remove the plug connector from the cover of the connector box.
3. Connect the pins of the connector with the enclosed jumpers according to the diagram, which corresponds to your application and is described in the following chapters.
4. Connect appropriate cables to the connector.
5. Reassemble the connector to the cover of the connector box.
6. Remove any remaining jumpers from the connector box.
7. Close the connector box.



Information

You can change the direction of rotation of the motor by changing two supply lines.

2.1 Motor connection with star connection

Connection diagram	Pin	Terminal	Connection
	1	U1	L1
	2	V1	L2
	3	W1	L3
	4		$U_{AC}^{1)}$
	5		
	6		Switching contact rectifier ¹⁾
	7		$U_{DC} (GND)^{1)}$
	8		Temperature sensor ²⁾
	9	W2	Jumper to pin 10
	10	U2	Jumper to pin 11
	11	V2	
	12		$U_{AC}^{1)}$
	13		
	14		Switching contact rectifier ¹⁾
	15		$+U_{DC}^{1)}$
	16		Temperature sensor ²⁾
		Protective conductor (PE)	

Plug connector from the cover of the connector box

1) See chapter "Brake connection"

2) See chapter "Temperature sensor"

2.2 Motor connection with delta connection



Connection diagram	Pin	Terminal	Connection
	1	U1	L1
	2	V1	L2
	3	W1	L3
	4		$U_{AC}^{1)}$
	5		
	6		Switching contact rectifier ¹⁾
	7		$U_{DC} (GND)^{1)}$
	8		Temperature sensor ²⁾
	9	W2	Jumper to pin 1
	10	U2	Jumper to pin 2
	11	V2	Jumper to pin 3
	12		$U_{AC}^{1)}$
	13		
	14		Switching contact rectifier ¹⁾
	15		$+U_{DC}^{1)}$
	16		Temperature sensor ²⁾
		Protective conductor (PE)	

Plug connector from the cover of the connector box

1) See chapter "Brake connection"

2) See chapter "Temperature sensor"

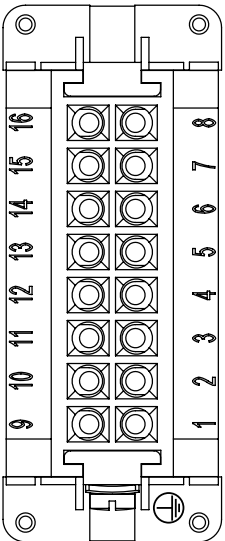
2.3 Motor connection with star/delta connection

Connection diagram	Pin	Terminal	Connection
 <p>Plug connector from the cover of the connector box</p>	1	U1	U1
	2	V1	V1
	3	W1	W1
	4		$U_{AC}^{1)}$
	5		
	6		Switching contact rectifier ¹⁾
	7		$U_{DC} (GND)^{1)}$
	8		Temperature sensor ²⁾
	9	W2	W2
	10	U2	U2
	11	V2	V2
	12		$U_{AC}^{1)}$
	13		
	14		Switching contact rectifier ¹⁾
	15		$+U_{DC}^{1)}$
	16		Temperature sensor ²⁾
			Protective conductor (PE)

1) See chapter "Brake connection"

2) See chapter "Temperature sensor"

3 Options

3.1 Temperature sensor

NOTICE

The thermal winding protection can be damaged by electrical connection errors!

- Carefully note the type of the temperature sensor indicated on the motor name plate.

The temperature sensor is connected via the power connector. Details can be found in chapter "Power connection".

3.2 Connection for external fan motor

NOTICE

The external fan motor can be damaged by electrical connection errors!

- ▶ Check before making the connection whether the connection voltage and design of the external fan motor (see name plate) match the supply voltage or the selected connection diagram.

Note:

The external fan motor has its own connection box.

Connection type	Connection diagram
Three-phase current (delta connection)	
Three-phase current (star connection)	
Alternating current in the Steinmetz circuit with operating capacitor C _B	

3.3 Brake connection

NOTICE

The brake can be damaged by electrical connection errors!

- ▶ Read before connecting the brake the corresponding operation manual.
- ▶ Check before connecting the brake whether the external DC voltage or the output voltage of the rectifier matches the connection voltage of the brake U_{DC} (see name plate).
- ▶ Note the connection designations of the brake and the rectifier.

The brake is connected via the power connector. See chapter "Power Connection" for details.

3.3.1 Connection without rectifier

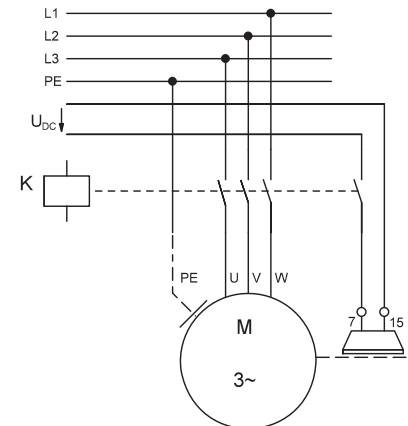

3.3.2 Connection with rectifier

NOTICE

The rectifier can be damaged by exceeding the maximum permissible ambient temperature!

- ▶ If you take full advantage of the rated power of the motor or operate the motor without forced air ventilation in the lower speed range on a drive controller, do not build a rectifier in the terminal box of the motor, but in a well-ventilated cabinet.



Information

When the brake needs to engage faster in time-critical applications, remove the bridge B and switch the brake simultaneously on the DC side (in the following circuit diagrams displayed as a dashed line).

Note:

The rectifier is installed as standard in the connector box and connected via the plug connector.

3.3.2.1 Rectifier with external power supply

NOTICE

The rectifier or brake can be damaged by electrical connection errors!

- ▶ Check before connecting the rectifier whether the external power supply matches the connection voltage of the rectifier U_{AC} . For the Powerbox rectifier is valid: $220\text{ V} \leq U_{AC} \leq 277\text{ V}$.

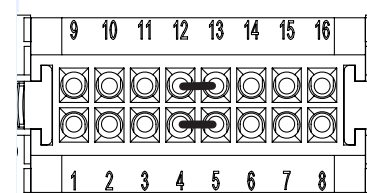
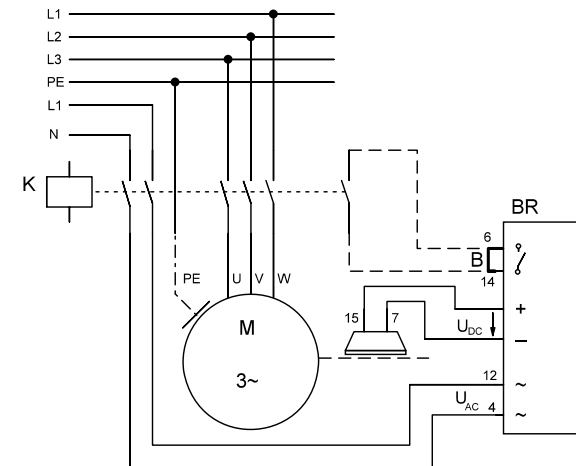

Connect pin 12 / 13 and pin 4 / 5 with jumpers.
If you do not switch the brake on the DC side, also connect pins 6 and 14.

Details on the power connection can be found in chapter "Power connection".

3.3.2.2 Rectifier with power supply from the motor with star connection

NOTICE

The rectifier or brake can be damaged by electrical connection errors!

- ▶ For the connection voltage of the rectifier is valid:
 $U_{AC} \geq \text{Line voltage } U_L \times 0,58$.
 For the Powerbox rectifier is valid additionally: $220 \text{ V} \leq U_{AC} \leq 277 \text{ V}$.
- ▶ The motor must not be connected to a drive controller, but only directly to the mains.
- ▶ The motor may start only connected directly to the mains (no star/delta connection).

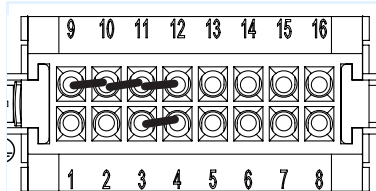
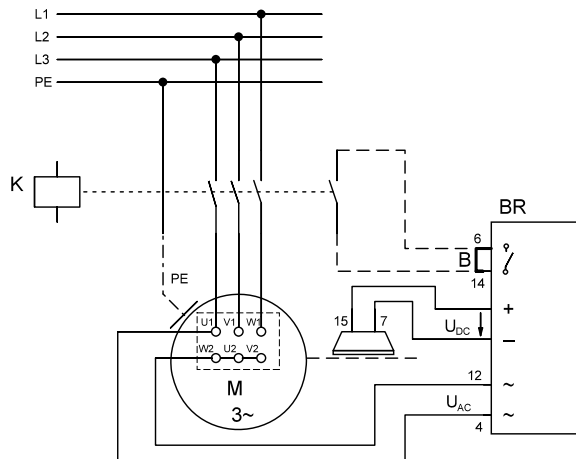

Connect pin 11 / 12 and pin 3 / 4 with jumpers.
 If you do not switch the brake on the DC side, also connect pins 6 and 14.

Details on the power connection can be found in chapter "Power connection".

3.3.2.3 Rectifier with power supply from the motor terminals (delta connection)

NOTICE

The rectifier or brake can be damaged by electrical connection errors!

- ▶ The Powerbox rectifier may **not** be connected to the motor terminals with delta connection.
- ▶ For the connection voltage of the rectifier is valid:
 $U_{AC} \geq \text{Line voltage } U_L$.
- ▶ The motor must not be connected to a drive controller, but only directly to the mains.
- ▶ The motor may start up only connected directly to the mains (no star/delta connection).

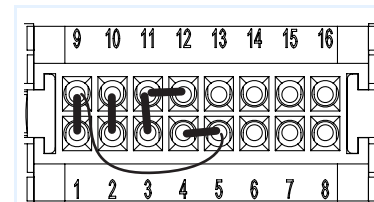
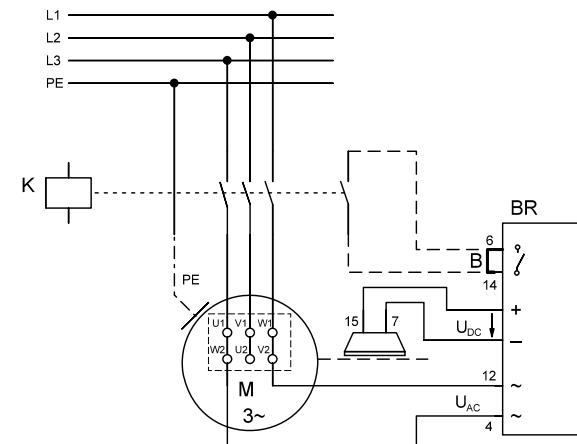

Connect pin 11 / 12 and pin 4 / 5 with jumpers and pin 5 / 9 with a wire.
 If you do not switch the brake on the DC side, also connect pins 6 and 14.

Details on the power connection can be found in chapter "Power connection".

3.4 Connection for encoder

NOTICE

The encoder can be damaged by connection errors!

- ▶ You should therefore check before making the connection whether the type of the encoder (see motor name plate) and the pin assignment of the plug connector match your application.

3.4.1 Incremental encoder

Color 1 of the motor-internal connecting wires applies up to motor size 80, color 2 applies starting with motor size 90.

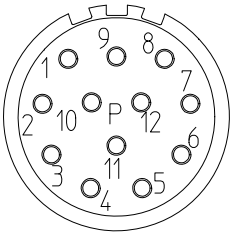
Connection diagram	Pin	Connection	Color 1	Color 2
 <p>Size con.23</p>	1	B –	PK	BK
	2	Up sense	–	YE
	3	N +	BU	PK
	4	N –	RD	WH
	5	A +	GN	GN
	6	A –	YE	BN
	7			
	8	B +	GY	GY
	9			
	10	0 V GND	WH	BU
	11	0 V GND	–	VT
	12	Up +	BN	RD

Further information on the encoder can be found on the nameplate of the motor.

3.4.2 Encoder SSI digital

This encoder is available only for asynchronous motors with external fan.

Multiturn absolute value encoder (SSI)

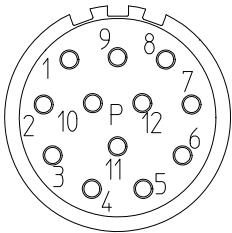
Connection diagram	Pin	Connection	Color
 <p>Size con.23</p>	1	Clock +	VT
	2*	Up sense	WHGN
	3		
	4		
	5	Data –	PK
	6	Data +	GY
	7		
	8	Clock –	YE
	9		
	10	0 V GND	WHGN
	11		
	12	Up +	BNGN

* Pin 2 is connected with pin 12 in the connection socket

3.4.3 Additional options

NOTICE

If your motor includes other options or attachment parts, make note of the corresponding technical documentation in addition.