

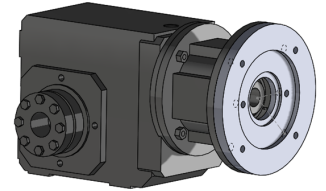

STOBER HYDRAULIC MOTOR ADAPTERS

Using a hydraulic motor with a STOBER gearbox has never been easier!

Give us the manufacturer and model of the motor and we will provide the appropriate adapter.



HOW DO WE MATE A HYDRAULIC MOTOR TO STOBER GEAR REDUCER?

Most hydraulic motors have 2 or 4 bolt SAE flanges. We design adapter plates and shaft hubs to mount the motors directly to our gearboxes.

Benefits of STOBER Hydraulic Motor Plate

- Use current SAE motor
- Ease of motor installation
- Ease of motor removal

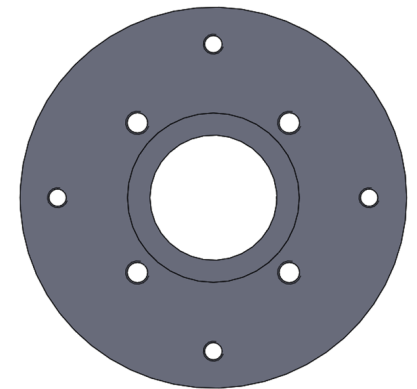
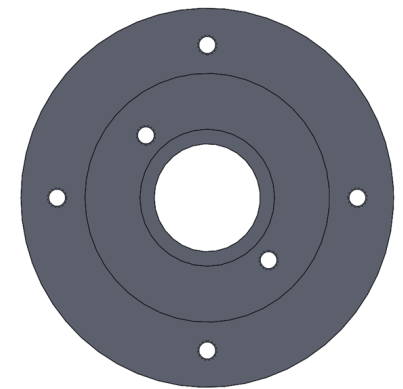
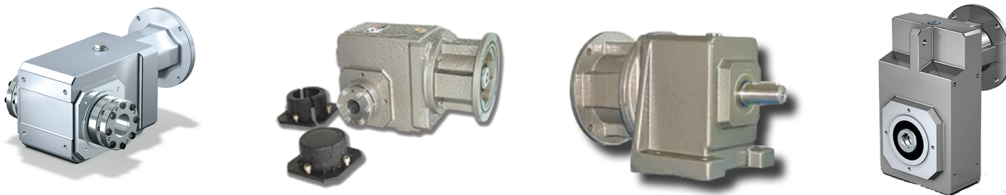

STOBER STANDARD SAE MOTOR ADAPTER OPTIONS MEAN MORE SOLUTIONS!

Plate Dimensions			
Pilot	Bolt Circle Diameter	Bolt Hole	Number of Holes
82.56	106.4	M12	2
101.6	127	M14	4
101.6	146.05	M12	2
127	161.9	M12	4
127	161.9	1/2 - 13 UNC	4

*Hydraulic motor shaft can be round keyed or splined.