

Connection method Manual

en-US
04/2026
ID 443102.06

Table of contents

- Table of contents 2**
- 1 Foreword 5**
- 2 User information 6**
 - 2.1 Directives and standards 6
 - 2.2 Timeliness 6
 - 2.3 Original language 6
 - 2.4 Limitation of liability 6
 - 2.5 Formatting conventions 7
 - 2.5.1 Display of warning messages and information 7
 - 2.5.2 Distinction of text elements 8
 - 2.5.3 Conventions for cables 8
 - 2.6 Trademarks 8
- 3 Safety notes 9**
- 4 Overview 10**
 - 4.1 Encoder cables 10
 - 4.2 Power cables 11
 - 4.3 One Cable Solution EnDat 3 and HIPERFACE DSL 11
- 5 Length definition for ready-made cables 12**
- 6 Encoder cables 13**
 - 6.1 Connection description and technical data 13
 - 6.1.1 EnDat 2.1/2.2 digital encoders 13
 - 6.1.2 Differential HTL incremental encoders 19
 - 6.1.3 SSI encoders 25
 - 6.1.4 Resolver 29
 - 6.1.5 EnDat 2.1 sin/cos encoders 41
 - 6.1.6 EnDat 3 or HIPERFACE DSL encoders 48
 - 6.2 Determining the cable code for ready-made cables 49
 - 6.2.1 Codes for EZ, EZHD, EZHP, EZS, EZM synchronous servo motors 49
 - 6.2.2 Codes for ED, EK synchronous servo motors 50
 - 6.2.3 Codes for IE2, IE3 asynchronous motors 51
 - 6.3 Ready-made encoder cables 52
 - 6.4 Service packs for encoder cables 55
 - 6.5 Accessories 55
 - 6.5.1 HTL-to-TTL adapter 55
 - 6.5.2 Interface adapters 56
 - 6.5.3 Adapter cables 56
 - 6.5.4 Encoder battery module 57
 - 6.5.5 Encoder adapter box 57
 - 6.5.6 Axis switcher 58

7	Power cables	59
7.1	Connection description	59
7.2	Technical data.....	67
7.3	Power cables for asynchronous motors	74
7.3.1	Assignment of motor to minimum cross-section	74
7.3.2	Checking the minimum cross-section for non-terminated power cables.....	75
7.3.3	Non-terminated power cables.....	76
7.4	Power cables for synchronous motors	77
7.4.1	Determining the cable code for ready-made cables in 3 steps	77
7.4.2	Ready-made power cables	95
7.5	Service packs for power cables.....	99
7.6	Accessories	99
7.6.1	TEP output choke.....	99
8	One Cable Solution	102
8.1	Connection description	102
8.2	Technical data.....	104
8.3	Determining the cable code for ready-made cables in 3 steps	109
8.3.1	Sizes for EZ, EZS synchronous servo motors	110
8.3.2	Checking the minimum cross-section and contact length.....	113
8.3.3	Codes for EZ, EZS synchronous servo motors.....	114
8.4	Ready-made hybrid cables	115
8.5	Accessories	116
8.5.1	TEP output choke.....	116
9	Appendix	118
9.1	Terminal specifications.....	118
9.1.1	SB6 drive controller – X20	118
9.1.2	SC6 drive controller – X20	118
9.1.3	SI6 drive controller – X20.....	119
9.1.4	SD6 drive controller – X20	119
9.1.5	FDS 5000 frequency inverter – X20	120
9.1.6	MDS 5000 servo inverter – X20	120
9.1.7	SDS 5000 servo inverter – X20.....	121
9.2	EMC recommendations	122
9.3	Detailed information	123
9.4	Formula symbols	123
10	Contact	124
10.1	Consultation, service and address.....	124
10.2	Your opinion is important to us.....	124
10.3	Close to customers around the world	125

Glossary	126
List of figures.....	128
List of tables.....	129

1 Foreword

A drive controller, cable and motor that are not coordinated with one another can lead to impermissibly high voltage peaks in the drive system, which may cause damage to the motor. The legal requirements of (EMC) Directive 2014/30/EU must also be observed.

The combination of STOBER motors with STOBER cables and STOBER drive controllers enables compliance with legal requirements.

STOBER offers a range of cables to match. Cables are available in different lengths and are ready-made on both ends.

Using unsuitable cables may void any claims made under the warranty.

Features

- One Cable Solution EnDat 3 and Hiperface DSL available
- Torsional stress $\pm 30^\circ/\text{m}$
- Bending resistance
- Oil resistance
- Chemical resistance

2 User information

This documentation describes the available STOBER power, encoder and hybrid cables. It provides you with assistance in selecting the right cable and with relevant information about properly connecting to the motor and drive controller without any errors.

2.1 Directives and standards

The following European directives and standards are relevant for STOBER cables:

- Low Voltage Directive 2014/35/EU
- EN 60204-1:2019-06: Safety of machinery – Electrical equipment of machines – Part 1
- DIN VDE 0298-4:2023-06: Use of cables and insulated lines for power systems – Part 4

Subsequent references to the standards do not specify the respective year in order to improve readability.

2.2 Timeliness

Check whether you have the latest version of this documentation. The latest document versions for our products are available for download on our website:

<http://www.stoeber.de/en/downloads/>.

2.3 Original language

The original language of this documentation is German; all other language versions are derived from the original language.

2.4 Limitation of liability

This documentation was created taking into account the applicable standards and regulations as well as the current state of technology.

No warranty or liability claims for damage shall result from failure to comply with the documentation or from use that deviates from the intended use of the product. This is especially true for damage caused by individual technical modifications to the product or the project configuration and operation of the product by unqualified personnel.

2.5 Formatting conventions

Orientation guides in the form of signal words, symbols and special text markups are used to emphasize specific information so that you are able identify it in this documentation quickly.

2.5.1 Display of warning messages and information

Warning messages are identified with symbols. They indicate special risks when handling the product and are accompanied by relevant signal words that express the extent of the risk. Furthermore, useful tips and recommendations for efficient, error-free operation are specially highlighted.

ATTENTION!

Attention

This indicates that damage to property may occur

- if the stated precautionary measures are not taken.
-

CAUTION!

Caution

This word with a warning triangle indicates that minor personal injury may occur

- if the stated precautionary measures are not taken.
-

WARNING!

Warning

This word with a warning triangle means there may be a considerable risk of fatal injury

- if the stated precautionary measures are not taken.
-

DANGER!

Danger

This word with a warning triangle indicates that there is a considerable risk of fatal injury

- if the stated precautionary measures are not taken.
-

Information

Information indicates important information about the product or serves to emphasize a section in the documentation that deserves special attention from the reader.

2.5.2 Distinction of text elements

Certain elements of the continuous text are distinguished as follows.

Important information	Words or expressions with a special meaning
Interpolated position mode	Optional: File or product name or other name
<u>Detailed information</u>	Internal cross-reference
http://www.samplelink.com	External cross-reference

2.5.3 Conventions for cables

In the cable connection descriptions, core colors are shortened and used as follows.

Cable colors

BK:	BLACK	PK:	PINK
BN:	BROWN	RD:	RED
BU:	BLUE	VT:	VIOLET
GN:	GREEN	WH:	WHITE
GY:	GRAY	YE:	YELLOW
OG:	ORANGE		

Formatting conventions

Two-colored core:	WHYE	WHITEYELLOW (white-yellow core)
Single-colored core:	BK/BN	BLACK/BROWN (black or brown core)
Core pair:	BU-BK	BLUE-BLACK (blue and black core)

2.6 Trademarks

The following names are trademarks or registered trademarks of other companies:

EnDat [®]	EnDat [®] and the EnDat [®] logo are registered trademarks of Dr. Johannes Heidenhain GmbH, Germany.
HIPERFACE [®]	HIPERFACE [®] and the HIPERFACE DSL [®] logo are registered trademarks of SICK AG, Germany.
speedtec [®]	speedtec [®] is a registered trademark of TE Connectivity Industrial GmbH, Germany.

All other trademarks not listed here are the property of their respective owners.

Products that are registered as trademarks are not specially indicated in this documentation. Existing property rights (patents, trademarks, protection of utility models) are to be observed.

3 Safety notes

WARNING!

Risk of fatal injury if safety notes and residual risks are not observed!

Failure to observe the safety notes and residual risks in the drive controller and motor documentation may result in accidents causing serious injury or death.

- Observe the safety notes in the drive controller and motor documentation.
 - Consider the residual risks in the risk assessment for the machine or system.
-

4 Overview

4.1 Encoder cables

Design	Motor plug connector size		
	con.15	con.17	con.23
Quick-lock	✓		
speedtec quick-lock		✓	✓

Encoder	Motor plug connector size			
	con.15	con.17	con.23 synchronous	con.23 asynchronous
EnDat 2.1/2.2 digital	✓	✓	✓	
Incremental (HTL)				✓
SSI				✓
Resolver	✓	✓	✓	
EnDat 2.1 sin/cos	✓	✓	✓	

Information

In combination with an EnDat 3 or HIPERFACE DSL encoder, you require hybrid cables which feature encoder communication and power transmission in a shared cable. STOBER OCS hybrid cables were specially developed for use in cable carriers with cable lengths up to 100 m. With line lengths up to 50 m, they can also be used in dynamic applications without an additional output choke.

For an overview of the motor connection using hybrid cables, see [One Cable Solution EnDat 3 and HIPERFACE DSL \[▶ 11\]](#).

Encoder	Supply cores	Pilot cores	Cable Ø	Bending radius 1 (min.)	Bending radius 2 (min.)
EnDat 2.1/2.2 digital	2 × 0.25 mm ²	3 × 2 × 0.14 mm ²	Max. 6.7 mm	67.0 mm	33.5 mm
Incremental (HTL)	2 × 0.25 mm ²	3 × 2 × 0.14 mm ²	Max. 6.7 mm	67.0 mm	33.5 mm
SSI	2 × 0.25 mm ²	3 × 2 × 0.14 mm ²	Max. 6.7 mm	67.0 mm	33.5 mm
Resolvers	2 × 0.25 mm ²	3 × 2 × 0.25 mm ²	Max. 10.3 mm	103.0 mm	51.5 mm
EnDat 2.1 sin/cos	2 × 0.34 mm ²	2 × 2 × 0.25 mm ² + 4 × 2 × 0.14 mm ²	Max. 8.7 mm	87.0 mm	43.5 mm

Bending radius: 1 = free to move, 2 = fixed installation

4.2 Power cables

Design	Motor plug connector size			
	con.15	con.23	con.40	con.58
Quick-lock	✓			
speedtec quick-lock		✓	✓	
Screw technology		On request	On request	✓

Power cores (3 + PE)	Brake cores	Temperature sensor cores	Cable Ø	Bending radius 1 (min.)	Bending radius 2 (min.)
4 × 1.0 mm ²	2 × 0.5 mm ²	2 × 0.34 mm ²	Max. 10.1 mm	101.0 mm	50.5 mm
4 × 1.5 mm ²	2 × 1.0 mm ²	2 × 0.5 mm ²	Max. 12.2 mm	122.0 mm	61.0 mm
4 × 2.5 mm ²	2 × 1.0 mm ²	2 × 1.0 mm ²	Max. 15.1 mm	151.0 mm	75.5 mm
4 × 4.0 mm ²	2 × 1.5 mm ²	2 × 1.0 mm ²	Max. 16.8 mm	168.0 mm	84.0 mm
4 × 10.0 mm ²	2 × 1.5 mm ²	2 × 1.0 mm ²	Max. 22.3 mm	223.0 mm	111.5 mm
4 × 16.0 mm ²	2 × 1.5 mm ²	2 × 1.5 mm ²	Max. 25.0 mm	250.0 mm	125.0 mm
4 × 25.0 mm ²	2 × 1.5 mm ²	2 × 1.5 mm ²	Max. 27.5 mm	275.0 mm	137.5 mm

Bending radius: 1 = free to move, 2 = fixed installation

4.3 One Cable Solution EnDat 3 and HIPERFACE DSL

Design	Motor plug connector size			
	con.23			
speedtec quick-lock	✓			

Power cores (3 + PE)	Brake cores	Pilot cores	Cable Ø	Bending radius 1 (min.)	Bending radius 2 (min.)
OCS-Basic (up to max. 12.5 m)					
4 × 1.0 mm ²	2 × 0.75 mm ²	2 × AWG22	Max. 13.6 mm	136.0 mm	68.0 mm
4 × 1.5 mm ²	2 × 1.0 mm ²	2 × AWG22	Max. 13.7 mm	137.0 mm	68.5 mm
OCS-Advanced (up to 100 m)					
4 × 1.5 mm ²	2 × 0.75 mm ²	2 × AWG22	Max. 14.7 mm	147.0 mm	73.5 mm
4 × 2.5 mm ²	2 × 0.75 mm ²	2 × AWG22	Max. 16.8 mm	168.0 mm	84.0 mm

Bending radius: 1 = free to move, 2 = fixed installation

5 Length definition for ready-made cables

The following length definitions apply to ready-made cables from STOBER.

Encoder cables

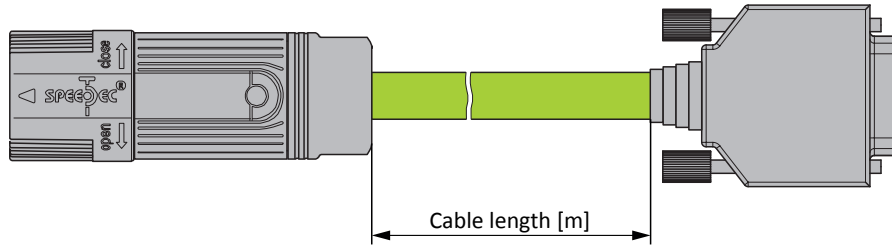

Fig. 1: Length definition for ready-made encoder cables

Power cable

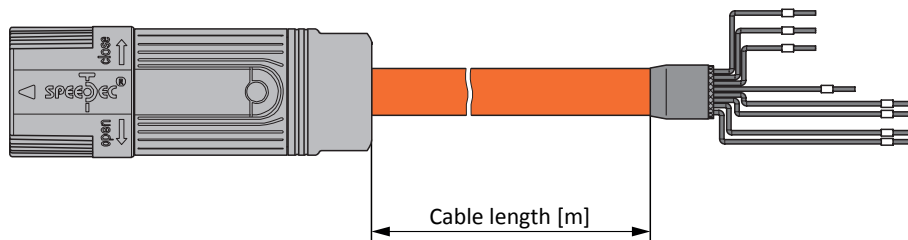

Fig. 2: Length definition for ready-made power cables – SB6, SC6, S16

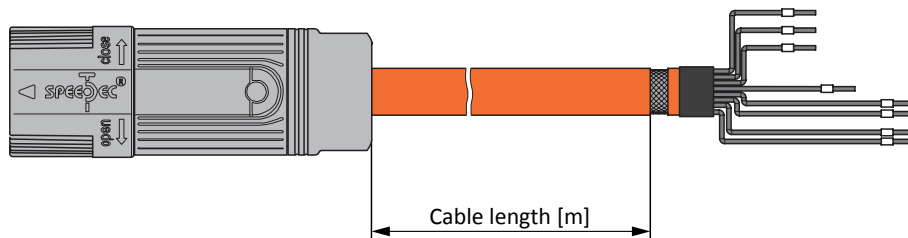

Fig. 3: Length definition for ready-made power cables – FDS 5000, MDS 5000, SDS 5000 and SD6

One Cable Solution

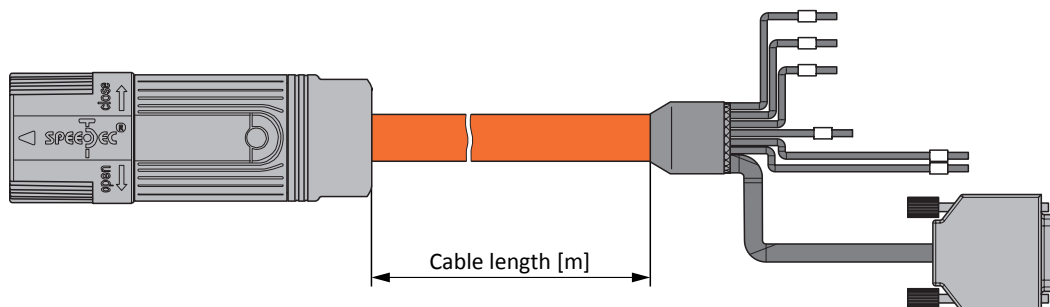

Fig. 4: Length definition for ready-made hybrid cables

6 Encoder cables

The motors are equipped with encoder systems and plug connectors as standard.

STOBER provides suitable cables in various lengths, conductor cross-sections and connector sizes.

Depending on the respective motor types, different encoder systems can be used.

6.1 Connection description and technical data

Connection descriptions and technical data of the available encoder cables can be found in the following chapters.

6.1.1 EnDat 2.1/2.2 digital encoders

Suitable encoder cables are described below.

6.1.1.1 Connection description

Depending on the size of the motor plug connector, encoder cables are available in the following designs:

- Quick-lock for con.15
- speedtec quick-lock for con.17 and con.23

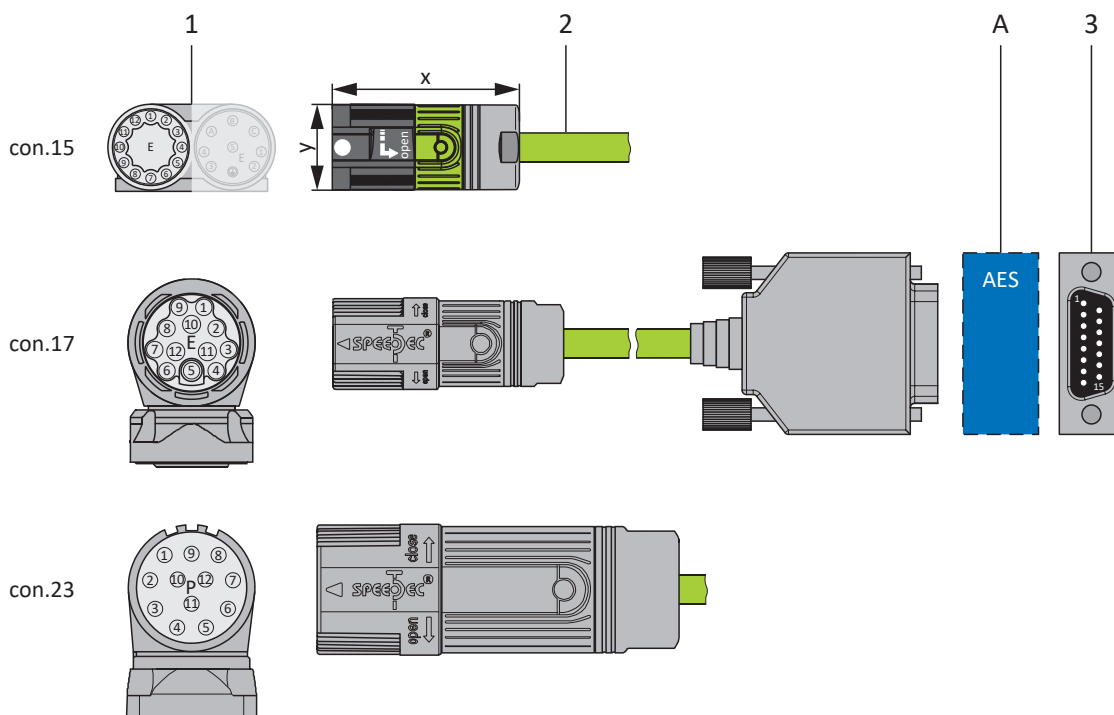

- 1 Plug connectors
- 2 Encoder cables
- A Only con.15 and con.17: Optional Absolute Encoder Support (AES) battery module
- 3 D-sub X4/X14

Encoder cables – con.15 plug connectors

With the "EBI 1135" and "EBI 135" EnDat 2.2 encoders, the supply voltage must also be buffered. The AES battery module can be used for buffering. The AES battery modules are available as accessories for the drive controllers. In this case, pin 2 and pin 3 of the motor are assigned to the U_{2BAT} buffer battery. Note that the encoder cable must not be connected to the encoder interface of the drive controller, but rather to the AES battery module for these encoders.

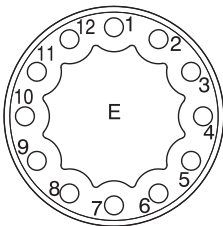
Motor (1)		Cable (2)	Drive controller (3)	
Connection diagram	Pin	Designation	Core color	
	1	Clock +	YE	Pin X4/X140 8
	2	U_{2BAT+} ¹	PK	12
	3	U_{2BAT-} ²	GY	3
	4	—	—	—
	5	Data -	BN	13
	6	Data +	WH	5
	7	—	—	—
	8	Clock -	GN	15
	9	—	—	—
	10	0 V GND	BU	2
	11	—	—	—
	12	U_2	RD	4
	Housing	Shield	—	Housing

Tab. 1: con.15 encoder cable pin assignment, EnDat 2.1/2.2 digital

Length x [mm]	Diameter y [mm]
42	18.7

Tab. 2: con.15 connector dimensions

¹ Only relevant for EBI encoders

² Only relevant for EBI encoders

Encoder cables – con.17 plug connectors

With the "EBI 1135" and "EBI 135" EnDat 2.2 encoders, the supply voltage must also be buffered. The AES battery module can be used for buffering. The AES battery modules are available as accessories for the drive controllers. In this case, pin 2 and pin 3 of the motor are assigned to the U_{2BAT} buffer battery. Note that the encoder cable must not be connected to the encoder interface of the drive controller, but rather to the AES battery module for these encoders.

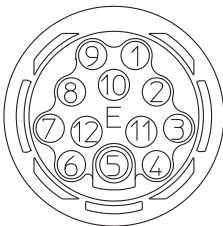
Motor (1)		Cable (2)	Drive controller (3)	
Connection diagram	Pin	Designation	Core color	
			Pin X4/X140	
	1	Clock +	YE	8
	2	U_{2BAT+} ³	PK	12
	3	U_{2BAT-} ⁴	GY	3
	4	—	—	—
	5	Data -	BN	13
	6	Data +	WH	5
	7	—	—	—
	8	Clock -	GN	15
	9	—	—	—
	10	0 V GND	BU	2
	11	—	—	—
	12	U_2	RD	4
	Housing	Shield	—	Housing

Tab. 3: con.17 encoder cable pin assignment, EnDat 2.1/2.2 digital

Length x [mm]	Diameter y [mm]
56	22

Tab. 4: con.17 connector dimensions

³ Only relevant for EBI encoders

⁴ Only relevant for EBI encoders

Encoder cables – con.23 plug connectors

Motor (1)		Cable (2)	Drive controller (3)
Connection diagram	Pin	Designation	Core color
	8	Clock +	YE
	12	U ₂ Sense ^{5 6}	PK
	—	—	—
	—	—	—
	13	Data –	BN
	5	Data +	WH
	—	—	—
	15	Clock –	GN
	—	—	—
	2	0 V GND	BU
	—	—	—
	4	U ₂	RD
	Housing	Shield	—

Tab. 5: con.23 encoder cable pin assignment, EnDat 2.1/2.2 digital

Length x [mm]	Diameter y [mm]
58	26

Tab. 6: con.23 plug dimensions

6.1.1.2 Technical data

IP protection class of the plug connectors

The plug connectors meet the IP 66/67 protection class (in accordance with IEC 60529). This information applies if both parts of the plug connector are connected together properly. Plug connectors have to be protected against environmental factors that affect functionality (dust, moisture, etc.) in accordance with the type approval laws.

Conductor design

Flexible, bare copper; all elements mounted in a round design at optimum length with filler

Peak operating voltage

Voltage: max. 300 V

Test voltage

Core/core and core/shield: 2000 V × 5 min

⁵ Only relevant for ECI 1319 or EQI 1331 encoders

⁶ Not applicable for delivery dates in June 2025 or later

Limit temperature

Temperature range by operating mode	DIN VDE	UL/CSA
Permanently installed	-50 °C to +90 °C	Up to +80 °C
Free to move	-40 °C to +90 °C	Up to +80 °C

Tensile stress when being laid

- Free to move: 20 N per mm² conductor cross-section
- Permanently installed: 50 N per mm² conductor cross-section

Smallest permissible bending radius

- Freely movable: 10 x d_{out}
- Permanently installed: 5 x d_{out}

Torsional stress

± 30°/m

Bending resistance

Trailable with 5 million bending cycles at a travel velocity of 180 m/min and an acceleration of 5 m/s² under optimum ambient conditions

Resistance

- Oil-resistant: in accordance with EN 50363-10-2
- Chemical: UV-resistant in accordance with EN 50289-4-17, hydrolysis-resistant in accordance with EN 50396, microbacteria-resistant

Outer sheath

PUR

Banding

Fleece tape with overlapping

Core insulation

PP

Core identification

Pair	Colors	
2 × 0.14	YE	GN
2 × 0.14	BN	WH
2 × 0.14	PK	GY
2 × 0.25	BU	RD

Sheath identification

Green color (similar to RAL 6018) imprinted with STOBER and No. "5050044"

Shield design

- Copper braid, tin-plated
- Cover: $\geq 90\%$

Insulation material

Halogen-free in accordance with EN 60754-1, silicone-free, CFC-free, free from paint-wetting impairment substances (PWIS)

Flammability

Combustion behavior: flame retardant and self-extinguishing in accordance with IEC 60332-1-2, UL/CSA FT1, UL VW-1

RoHS conformity

Free of hazardous substances in accordance with the RoHS-2 Directive 2011/65/EU and RoHS-3 Directive 2015/863

Conductor cross-sections

Cable diameter	Description	Weight	ID No. (non-terminated cable)	
			New	Previously
Max. 6.7 mm	(3 x 2 x 0.14 mm ² + 2 x 0.25 mm ²)	85 g/m	5050044	49484

"(...)" = Shield

Design

UL/CSA (E172204, E170315 or E356538); for UL file number, see cable imprint

Capacitance, inductance, DC resistance

Operating capacitance in accordance with EN 50395 clause 8.1	
Pair 0.14 mm ²	Max. 100 nF/km
Pair 0.25 mm ²	Max. 100 nF/km

Inductance in accordance with EN 50289-1-12	
Pair 0.14 mm ²	Max. 0.8 mH/km
Pair 0.25 mm ²	Max. 0.8 mH/km

DC resistance at 20 °C	
Pair 0.14 mm ²	139.3 Ω /km
Pair 0.25 mm ²	78.0 Ω /km

6.1.2 Differential HTL incremental encoders

Suitable encoder cables are described below.

6.1.2.1 Connection description

The encoder cable is available in plug connector size con.23 with a speedtec quick-lock.

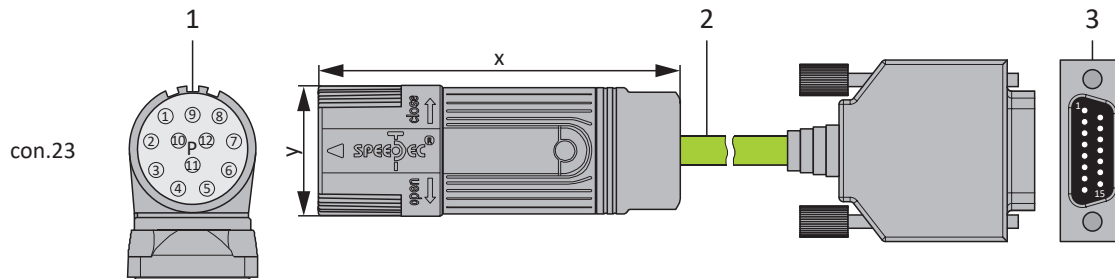

- 1 Plug connectors
- 2 Encoder cables
- 3 D-sub X4

Information

For the connection of an HTL incremental encoder to terminal X4 of SC6 or SI6 drive controllers, you need the HT6 adapter (ID No. 56665). HT6 takes over level conversion from HTL signals to TTL signals.

Encoder cables – con.23 plug connectors

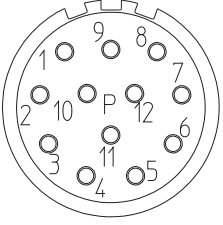
Connection diagram	Motor (1)		Cable (2)	Drive controller (3)
	Pin	Designation	Core color	Pin X4
	1	B -	YE	9
	2	—	—	—
	3	N +	PK	3
	4	N -	GY	10
	5	A +	BN	6
	6	A -	WH	11
	7	—	—	—
	8	B +	GN	1
	9	—	—	—
	10	0 V GND	BU	2 ⁷
	11	—	—	—
	12	U ₂	RD	4
	Housing	Shield	—	Housing

Tab. 7: con.23 encoder cable pin assignment, incremental HTL

Length x [mm]	Diameter y [mm]
58	26

Tab. 8: con.23 plug dimensions

⁷ Pin 12 (U₂ Sense) with pin 2 (0 V GND) bridged: The bridge is constructed in the cable connector that is connected to X4.

6.1.2.2 HT6 interface adapter (HTL to TTL)

HT6 – HTL to TTL (15-pin to 15-pin)

Interface adapter for level conversion from HTL signals to TTL signals for connecting the encoder cable to the SC6 and SI6 drive controllers.

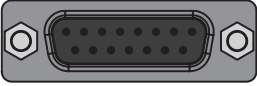
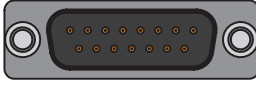
Socket ⁸	Pin	Designation	Function	Pin	Connector ⁹
8 7 6 5 4 3 2 1	1	B +	Differential input for B track	5	1 2 3 4 5 6 7 8
	2	0 V GND	Reference potential for encoder supply to pin 4	2	
15 14 13 12 11 10 9	3	N +	Differential input for N track	7	9 10 11 12 13 14 15
	4	U ₂	Encoder supply	4	
	5	—	—	—	
	6	A +	Differential input for A track	8	
	7	—	—	—	
	8	—	—	—	
	9	B –	Inverse differential input for B track	13	
	10	N –	Inverse differential input for N track	14	
	11	A –	Inverse differential input for A track	15	
	12	—	—	—	
	13	—	—	—	
	14	—	—	—	
	15	—	—	—	

Tab. 9: HT6 connection description for HTL differential encoder (15-pin to 15-pin)

⁸View of 15-pin D-sub for connecting the encoder cable

⁹View of 15-pin D-sub for connecting to terminal X4

6.1.2.3 Technical data

IP protection class of the plug connectors

The plug connectors meet the IP 66/67 protection class (in accordance with IEC 60529). This information applies if both parts of the plug connector are connected together properly. Plug connectors have to be protected against environmental factors that affect functionality (dust, moisture, etc.) in accordance with the type approval laws.

Conductor design

Flexible, bare copper; all elements mounted in a round design at optimum length with filler

Peak operating voltage

Voltage: max. 300 V

Test voltage

Core/core and core/shield: 2000 V × 5 min

Limit temperature

Temperature range by operating mode	DIN VDE	UL/CSA
Permanently installed	-50 °C to +90 °C	Up to +80 °C
Free to move	-40 °C to +90 °C	Up to +80 °C

Tensile stress when being laid

- Free to move: 20 N per mm² conductor cross-section
- Permanently installed: 50 N per mm² conductor cross-section

Smallest permissible bending radius

- Freely movable: 10 x d_{out}
- Permanently installed: 5 x d_{out}

Torsional stress

± 30°/m

Bending resistance

Trailable with 5 million bending cycles at a travel velocity of 180 m/min and an acceleration of 5 m/s² under optimum ambient conditions

Resistance

- Oil-resistant: in accordance with EN 50363-10-2
- Chemical: UV-resistant in accordance with EN 50289-4-17, hydrolysis-resistant in accordance with EN 50396, microbacteria-resistant

Outer sheath

PUR

Banding

Fleece tape with overlapping

Core insulation

PP

Core identification

Pair	Colors	
2 × 0.14	YE	GN
2 × 0.14	BN	WH
2 × 0.14	PK	GY
2 × 0.25	BU	RD

Sheath identification

Green color (similar to RAL 6018) imprinted with STOBER and No. "5050044"

Shield design

- Copper braid, tin-plated
- Cover: ≥ 90%

Insulation material

Halogen-free in accordance with EN 60754-1, silicone-free, CFC-free, free from paint-wetting impairment substances (PWIS)

Flammability

Combustion behavior: flame retardant and self-extinguishing in accordance with IEC 60332-1-2, UL/CSA FT1, UL VW-1

RoHS conformity

Free of hazardous substances in accordance with the RoHS-2 Directive 2011/65/EU and RoHS-3 Directive 2015/863

Conductor cross-sections

Cable diameter	Description	Weight	ID No. (non-terminated cable)	
			New	Previously
Max. 6.7 mm	(3 x 2 x 0.14 mm ² + 2 x 0.25 mm ²)	85 g/m	5050044	49484

"(...)" = Shield

Design

UL/CSA (E172204, E170315 or E356538); for UL file number, see cable imprint

Capacitance, inductance, DC resistance

Operating capacitance in accordance with EN 50395 clause 8.1

Pair 0.14 mm ²	Max. 100 nF/km
Pair 0.25 mm ²	Max. 100 nF/km

Inductance in accordance with EN 50289-1-12

Pair 0.14 mm ²	Max. 0.8 mH/km
Pair 0.25 mm ²	Max. 0.8 mH/km

DC resistance at 20 °C

Pair 0.14 mm ²	139.3 Ω/km
Pair 0.25 mm ²	78.0 Ω/km

6.1.3 SSI encoders

Suitable encoder cables are described below.

6.1.3.1 Connection description

The encoder cable is available in plug connector size con.23 with a speedtec quick-lock.

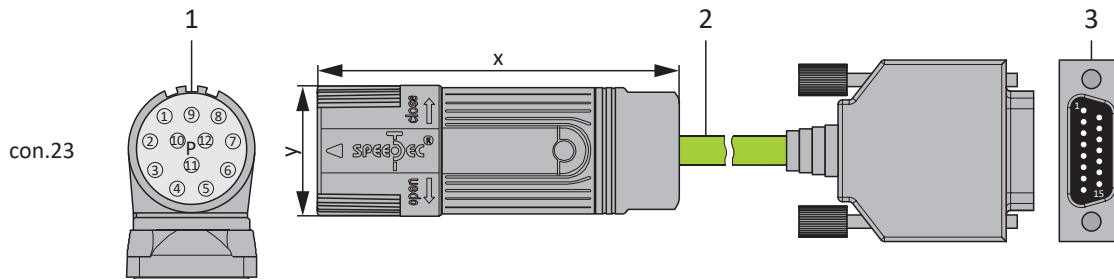

- 1 Plug connectors
- 2 Encoder cables
- 3 D-sub X4

Encoder cables – con.23 plug connectors

Connection diagram	Motor (1)		Cable (2)	Drive controller (3)	
	Pin	Designation	Core color	Pin X4	
	1	Clock +	YE	8	
	2	U ₂ Sense	PK	12	
	3	—	—	—	
	4	—	—	—	
	5	Data -	BN	13	
	6	Data +	WH	5	
	7	—	—	—	
	8	Clock -	GN	15	
	9	—	—	—	
	10	0 V GND	BU	2	
	11	—	—	—	
	12	U ₂	RD	4	
	Housing	Shield	—	Housing	

Tab. 10: con.23 encoder cable pin assignment, SSI

Length x [mm]	Diameter y [mm]
58	26

Tab. 11: con.23 plug dimensions

6.1.3.2 Technical data

IP protection class of the plug connectors

The plug connectors meet the IP 66/67 protection class (in accordance with IEC 60529). This information applies if both parts of the plug connector are connected together properly. Plug connectors have to be protected against environmental factors that affect functionality (dust, moisture, etc.) in accordance with the type approval laws.

Conductor design

Flexible, bare copper; all elements mounted in a round design at optimum length with filler

Peak operating voltage

Voltage: max. 300 V

Test voltage

Core/core and core/shield: 2000 V × 5 min

Limit temperature

Temperature range by operating mode	DIN VDE	UL/CSA
Permanently installed	-50 °C to +90 °C	Up to +80 °C
Free to move	-40 °C to +90 °C	Up to +80 °C

Tensile stress when being laid

- Free to move: 20 N per mm² conductor cross-section
- Permanently installed: 50 N per mm² conductor cross-section

Smallest permissible bending radius

- Freely movable: 10 x d_{out}
- Permanently installed: 5 x d_{out}

Torsional stress

± 30°/m

Bending resistance

Trailable with 5 million bending cycles at a travel velocity of 180 m/min and an acceleration of 5 m/s² under optimum ambient conditions

Resistance

- Oil-resistant: in accordance with EN 50363-10-2
- Chemical: UV-resistant in accordance with EN 50289-4-17, hydrolysis-resistant in accordance with EN 50396, microbacteria-resistant

Outer sheath

PUR

Banding

Fleece tape with overlapping

Core insulation

PP

Core identification

Pair	Colors	
2 × 0.14	YE	GN
2 × 0.14	BN	WH
2 × 0.14	PK	GY
2 × 0.25	BU	RD

Sheath identification

Green color (similar to RAL 6018) imprinted with STOBER and No. "5050044"

Shield design

- Copper braid, tin-plated
- Cover: ≥ 90%

Insulation material

Halogen-free in accordance with EN 60754-1, silicone-free, CFC-free, free from paint-wetting impairment substances (PWIS)

Flammability

Combustion behavior: flame retardant and self-extinguishing in accordance with IEC 60332-1-2, UL/CSA FT1, UL VW-1

RoHS conformity

Free of hazardous substances in accordance with the RoHS-2 Directive 2011/65/EU and RoHS-3 Directive 2015/863

Conductor cross-sections

Cable diameter	Description	Weight	ID No. (non-terminated cable)	
			New	Previously
Max. 6.7 mm	(3 x 2 x 0.14 mm ² + 2 x 0.25 mm ²)	85 g/m	5050044	49484

"(...)" = Shield

Design

UL/CSA (E172204, E170315 or E356538); for UL file number, see cable imprint

Capacitance, inductance, DC resistance

Operating capacitance in accordance with EN 50395 clause 8.1

Pair 0.14 mm ²	Max. 100 nF/km
Pair 0.25 mm ²	Max. 100 nF/km

Inductance in accordance with EN 50289-1-12

Pair 0.14 mm ²	Max. 0.8 mH/km
Pair 0.25 mm ²	Max. 0.8 mH/km

DC resistance at 20 °C

Pair 0.14 mm ²	139.3 Ω/km
Pair 0.25 mm ²	78.0 Ω/km

6.1.4 Resolver

Suitable encoder cables are described below.

6.1.4.1 Connection description

Depending on the size of the motor plug connector, encoder cables are available in the following designs:

- Quick-lock for con.15
- speedtec quick-lock for con.17 and con.23

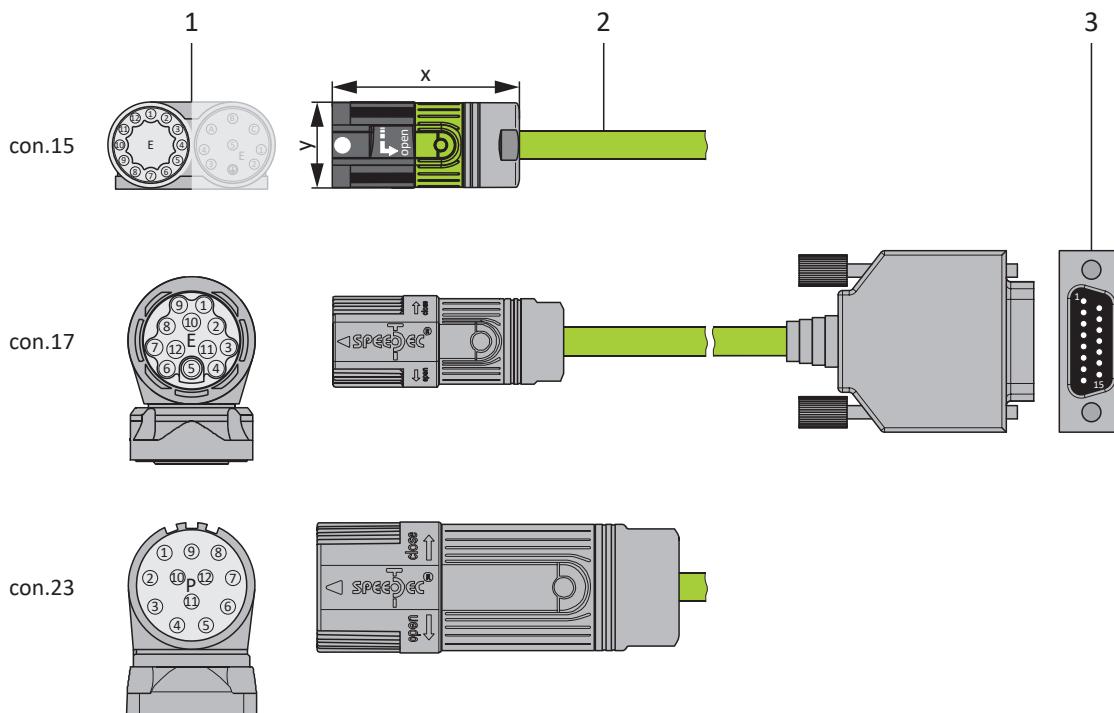

- 1 Plug connectors
- 2 Encoder cables
- 3 D-sub X4/X140/adapter

Information

Note that the cores for the temperature sensor are routed in the power cable as standard. For motors that provide the temperature sensor at the encoder connection, you need an interface adapter to lead out the temperature sensor cores for connecting the cable to the drive controller.

Information

For connecting con.23 resolver cables with a 9-pin D-sub connector, such as the standard design for ED/EK synchronous servo motors, you must use interface adapter AP6A00 (ID No. 56498) or AP6A01 (ID No. 56522, with motor temperature sensor leads), available separately.

6.1.4.1.1 Resolver cable with "Motion Resolver" imprint

Encoder cables – con.15 plug connectors

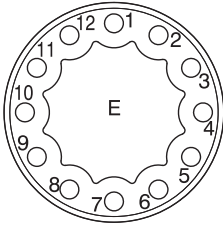
Connection diagram	Motor (1)		Cable (2)		Drive controller (3)
	Pin	Designation	Core color	Pair	Pin X4/X140
	1	S3 Cos +	GN	GN-BK	3
	2	S1 Cos –	BK	GN-BK	11
	3	S4 Sin +	WH	WH-BK	1
	4	S2 Sin –	BK	WH-BK	9
	5	1TP1	RD	RD-BK	7
	6	1TP2	BK	RD-BK	14
	7	R2 Ref +	BU	BU-BK	6
	8	R1 Ref –	BK	BU-BK	2
	9	–	–	–	–
	10	–	–	–	–
	11	–	–	–	–
	12	–	–	–	–
	Housing	Shield	–	–	Housing

Tab. 12: Encoder cable pin assignment con.15, resolver, "Motion Resolver" cable label

Length x [mm]	Diameter y [mm]
42	18.7

Tab. 13: con.15 connector dimensions

Encoder cables – con.17 plug connectors

Connection diagram	Motor (1)		Cable (2)		Drive controller (3)
	Pin	Designation	Core color	Pair	Pin X4/X140
	1	S3 Cos +	GN	GN-BK	3
	2	S1 Cos –	BK	GN-BK	11
	3	S4 Sin +	WH	WH-BK	1
	4	S2 Sin –	BK	WH-BK	9
	5	1TP1	RD	RD-BK	7
	6	1TP2	BK	RD-BK	14
	7	R2 Ref +	BU	BU-BK	6
	8	R1 Ref –	BK	BU-BK	2
	9	–	–	–	–
	10	–	–	–	–
	11	–	–	–	–
	12	–	–	–	–
	Housing	Shield	–	–	Housing

Tab. 14: Encoder cable pin assignment con.17, resolver, "Motion Resolver" cable label

Length x [mm]	Diameter y [mm]
56	22

Tab. 15: con.17 connector dimensions

Encoder cables – con.23 plug connectors

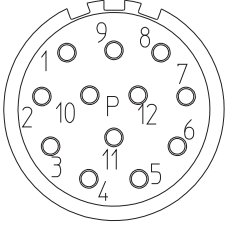
Connection diagram	Motor (1)		Cable (2)		Adapter (3)
	Pin	Designation	Core color	Pair	Pin 9-pin connector
	1	S3 Cos +	GN	GN-BK	8
	2	S1 Cos –	BK	GN-BK	4
	3	S4 Sin +	WH	WH-BK	7
	4	S2 Sin –	BK	WH-BK	3
	5	1TP1	RD	RD-BK	2
	6	1TP2	BK	RD-BK	6
	7	R2 Ref +	BU	BU-BK	9
	8	R1 Ref –	BK	BU-BK	5
	9	–	–	–	–
	10	–	–	–	–
	11	–	–	–	–
	12	–	–	–	–
	Housing	Shield	–	–	Housing

Tab. 16: Encoder cable pin assignment con.23, resolver, "Motion Resolver" cable label

Length x [mm]	Diameter y [mm]
58	26

Tab. 17: con.23 plug dimensions

6.1.4.1.2 Resolver cable with "No. 44206" imprint

Encoder cables – con.15 plug connectors

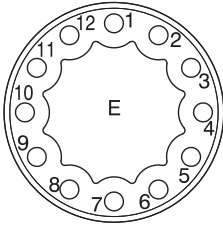
Motor (1)		Cable (2)	Drive controller (3)
Connection diagram	Pin	Designation	Core color
	1	S3 Cos +	YE
	2	S1 Cos –	GN
	3	S4 Sin +	WH
	4	S2 Sin –	BN
	5	1TP1	RD
	6	1TP2	BU
	7	R2 Ref +	GY
	8	R1 Ref –	PK
	9	–	–
	10	–	–
	11	–	–
	12	–	–
	Housing	Shield	–

Tab. 18: Encoder cable pin assignment con.15, resolver, "No. 44206" cable label

Length x [mm]	Diameter y [mm]
42	18.7

Tab. 19: con.15 connector dimensions

Encoder cables – con.17 plug connectors

Connection diagram	Motor (1)		Cable (2)	Drive controller (3)
	Pin	Designation	Core color	Pin X4/X140
	1	S3 Cos +	YE	3
	2	S1 Cos –	GN	11
	3	S4 Sin +	WH	1
	4	S2 Sin –	BN	9
	5	1TP1	RD	7
	6	1TP2	BU	14
	7	R2 Ref +	GY	6
	8	R1 Ref –	PK	2
	9	–	–	–
	10	–	–	–
	11	–	–	–
	12	–	–	–
	Housing	Shield	–	Housing

Tab. 20: Encoder cable pin assignment con.17, resolver, "No. 44206" cable label

Length x [mm]	Diameter y [mm]
56	22

Tab. 21: con.17 connector dimensions

Encoder cables – con.23 plug connectors

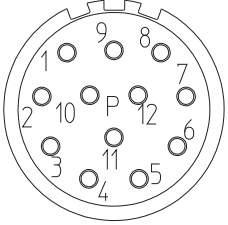
Connection diagram	Motor (1)		Cable (2)	Adapter (3)
	Pin	Designation	Core color	Pin 9-pin connector
	1	S3 Cos +	YE	8
	2	S1 Cos –	GN	4
	3	S4 Sin +	WH	7
	4	S2 Sin –	BN	3
	5	1TP1	RD	2
	6	1TP2	BU	6
	7	R2 Ref +	GY	9
	8	R1 Ref –	PK	5
	9	–	–	–
	10	–	–	–
	11	–	–	–
	12	–	–	–
	Housing	Shield	–	Housing

Tab. 22: Encoder cable pin assignment con.23, resolver, "No. 44206" cable label

Length x [mm]	Diameter y [mm]
58	26

Tab. 23: con.23 plug dimensions

6.1.4.2 AP6 interface adapter (resolver)

AP6A00 – Resolver (9-pin to 15-pin)

Interface adapter for connecting the resolver cable with 9-pin D-sub connector to the drive controller.

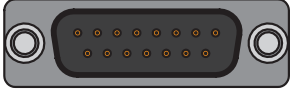
Socket ¹⁰	Pin	Designation	Function	Pin	Connector ¹¹
	1	—	—	—	
	2	1TP1	—	—	
	3	S2 Sin –	Reference potential for sin input	9	
	4	S1 Cos –	Reference potential for cos input	11	
	5	R1 Ref –	Reference potential for resolver excitation signal	2	
	6	1TP2	—	—	
	7	S4 Sin +	Sin input	1	
	8	S3 Cos +	Cos input	3	
	9	R2 Ref +	Resolver excitation signal	6	

Tab. 24: AP6A00 connection description for resolver (9-pin to 15-pin)

¹⁰View of 9-pin D-sub for connecting the SDS 4000-compatible resolver cable

¹¹View of 15-pin D-sub for connecting to X140 of the RI6 terminal module or to X4 of the SC6 or SI6 drive controller

AP6A01 – Resolver and motor temperature sensor (9-pin to 15-pin)

Interface adapter with temperature sensor cores led out at the side (core length: approx. 11 cm) for connecting the resolver cable with 9-pin D-sub connector to the drive controller.

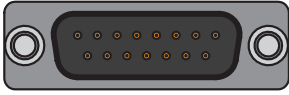
Socket ¹²	Pin	Designation	Function	Pin	Connector ¹³
 <p>1 2 3 4 5 6 7 8 9</p>	1	—	—	—	 <p>1 2 3 4 5 6 7 8 9 10 11 12 13 14 15</p>
	2	1TP1	Motor temperature sensor connection, if included in the encoder cable connector; routed out for the direct connection to terminal X2	—	
	3	S2 Sin –	Reference potential for sin input	9	
	4	S1 Cos –	Reference potential for cos input	11	
	5	R1 Ref –	Reference potential for resolver excitation signal	2	
	6	1TP2	Motor temperature sensor connection, if included in the encoder cable connector; routed out for the direct connection to terminal X2	—	
	7	S4 Sin +	Sin input	1	
	8	S3 Cos +	Cos input	3	
	9	R2 Ref +	Resolver excitation signal	6	

Tab. 25: AP6A01 connection description for the resolver and motor temperature sensor (9-pin to 15-pin)

¹²View of 9-pin D-sub for connecting the SDS 4000-compatible resolver cable

¹³View of 15-pin D-sub for connecting to terminal X4 or X140

6.1.4.3 Technical data

IP protection class of the plug connectors

The plug connectors meet the IP 66/67 protection class (in accordance with IEC 60529). This information applies if both parts of the plug connector are connected together properly. Plug connectors have to be protected against environmental factors that affect functionality (dust, moisture, etc.) in accordance with the type approval laws.

Conductor design

"No. 44206" cable imprint

Copper, bare, finely stranded; twisted pairs; optimized twisting of the pairs with filler in the gussets; wound with overlapping mesh tape

"Motion Resolver" cable imprint

Flexible, tin-plated copper; all elements mounted in a round design at optimum length with filler

Peak operating voltage

Voltage: max. 300 V

Test voltage

Core/core and core/shield: 1500 V × 5 min

Limit temperature

Temperature range by operating mode	DIN VDE	UL/CSA
Permanently installed	-50 °C to +90 °C	Up to +80 °C
Free to move	-40 °C to +90 °C	Up to +80 °C

Tensile stress when being laid

- Free to move: 20 N per mm² conductor cross-section
- Permanently installed: 50 N per mm² conductor cross-section

Smallest permissible bending radius

- Freely movable: 10 x d_{out}
- Permanently installed: 5 x d_{out}

Torsional stress

± 30°/m

Bending resistance

Trailable with 5 million bending cycles at a travel velocity of 180 m/min and an acceleration of 5 m/s² under optimum ambient conditions

Resistance

- Oil-resistant: in accordance with EN 50363-10-2
- Chemical: UV-resistant in accordance with EN 50289-4-17, hydrolysis-resistant in accordance with EN 50396, microbacteria-resistant

Outer sheath

PUR

Banding

Fleece tape with overlapping

Core insulation**"Motion Resolver" cable imprint**

PP

"No. 44206" cable imprint

TPE

Core identification**"Motion Resolver" cable imprint**

Pair	Colors	
2 × 0.25	BK	RD
2 × 0.25	BK	WH
2 × 0.25	BK	GN
2 × 0.25	BK	BU

"No. 44206" cable imprint

Pair	Colors	
2 × 0.14	YE	GN
2 × 0.14	BN	WH
2 × 0.14	PK	GY
2 × 0.25	BU	RD

Sheath identification

Yellow-green color (similar to RAL 6018) imprinted with "Motion Resolver" or with STOBER and "No. 44206"

Shield design

- Copper braid, tin-plated
- Cover: ≥ 80%

Insulation material

Halogen-free in accordance with EN 60754-1, silicone-free, CFC-free, free from paint-wetting impairment substances (PWIS)

Flammability

Combustion behavior: flame retardant and self-extinguishing in accordance with IEC 60332-1-2, UL/CSA FT1, UL VW-1

RoHS conformity

Free of hazardous substances in accordance with the RoHS-2 Directive 2011/65/EU and RoHS-3 Directive 2015/863

Conductor cross-sections and weights

"Motion Resolver" cable imprint

Cable diameter	Description	Weight	ID No. (non-terminated cable)
Max. 10.3 mm	$4 \times (2 \times 0.25 \text{ mm}^2)$	112 g/m	5052299

"No. 44206" cable imprint

Cable diameter	Description	Weight	ID No. (non-terminated cable)
Max. 11.4 mm	$3 \times (2 \times 0.14 \text{ mm}^2) + (2 \times 0.25 \text{ mm}^2)$	147 g/m	44206

"(...)" = Shield

Design

UL/CSA (E172204, E170315 or E356538); for UL file number, see cable imprint

Capacitance, inductance, DC resistance

"Motion Resolver" cable imprint

Operating capacitance in accordance with EN 50395 clause 8.1	
Pair 0.25 mm ²	On request

Inductance in accordance with EN 50289-1-12	
Pair 0.25 mm ²	On request

DC resistance at 20 °C	
Pair 0.25 mm ²	84.2 Ω/km

"No. 44206" cable imprint

Operating capacitance in accordance with EN 50395 clause 8.1	
Pair 0.14 mm ²	Max. 150 nF/km
Pair 0.25 mm ²	Max. 150 nF/km

Inductance in accordance with EN 50289-1-12	
Pair 0.14 mm ²	Max. 0.8 mH/km
Pair 0.25 mm ²	Max. 0.8 mH/km

DC resistance at 20 °C	
Pair 0.14 mm ²	139.3 Ω/km
Pair 0.25 mm ²	78.0 Ω/km

6.1.5 EnDat 2.1 sin/cos encoders

Suitable encoder cables are described below.

6.1.5.1 Connection description

Depending on the size of the motor plug connector, encoder cables are available in the following designs:

- Quick-lock for con.15
- speedtec quick-lock for con.17 and con.23

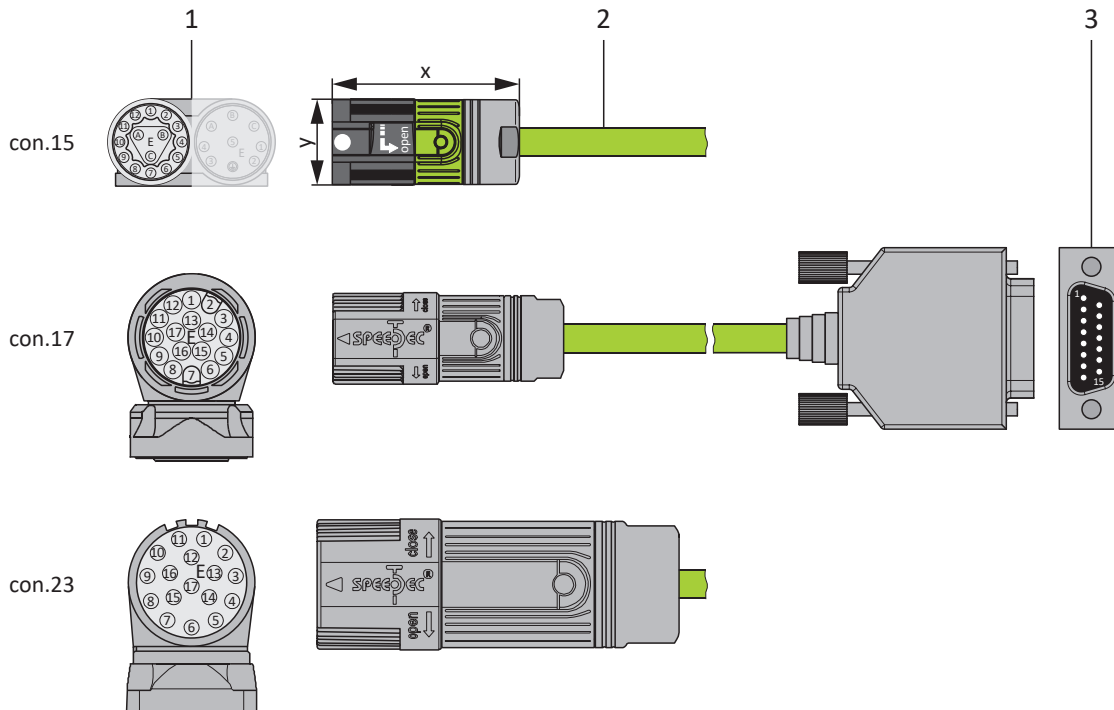

- 1 Plug connectors
- 2 Encoder cables
- 3 D-sub X140

Information

Note that the cores for the temperature sensor are routed in the power cable as standard. For motors that provide the temperature sensor at the encoder connection, you need an interface adapter to lead out the temperature sensor cores for connecting the cable to the drive controller.

Information

For connecting EnDat 2.1 sin/cos cables with a 15-pin D-sub connector to an integrated motor temperature sensor, you must use the AP6A02 interface adapter (ID No. 56523), available separately, to lead out the temperature sensor cores.

Encoder cables – con.15 plug connectors

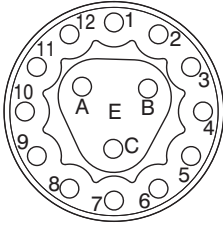
Connection diagram	Motor (1)		Cable (2)	Drive controller (3)
	Pin	Designation	Core color	Pin X140
	1	U ₂ Sense	GNRD	12
	2	0 V Sense	GNBK	10
	3	U ₂	BNRD	4
	4	Clock +	WHBK	8
	5	Clock -	WHYE	15
	6	0 V GND	BNBU	2
	7	B + (Sin +)	RD	9
	8	B - (Sin -)	OG	1
	9	Data +	GY	5
	10	A + (Cos +)	GN	11
	11	A - (Cos -)	YE	3
	12	Data -	BU	13
	A	1TP2	BNGY	14
	B	1TP1	BNYE	7
	C	—	—	—
	Housing	Shield	—	Housing

Tab. 26: con.15 encoder cable pin assignment, EnDat 2.1 sin/cos

Length x [mm]	Diameter y [mm]
42	18.7

Tab. 27: con.15 connector dimensions

Encoder cables – con.17 plug connectors

Motor (1)		Cable (2)		Drive controller (3)
Connection diagram	Pin	Designation	Core color	Pin X140
	1	U ₂ Sense	GNRD	12
	2	—	—	—
	3	—	—	—
	4	0 V Sense	GNBK	10
	5	1TP2	BNGY	14
	6	1TP1	BNYE	7
	7	U ₂	BNRD	4
	8	Clock +	WHBK	8
	9	Clock -	WHYE	15
	10	0 V GND	BNBU	2
	11	—	—	—
	12	B + (Sin +)	RD	9
	13	B - (Sin -)	OG	1
	14	Data +	GY	5
	15	A + (Cos +)	GN	11
	16	A - (Cos -)	YE	3
	17	Data -	BU	13
Housing	Shield	—	Housing	

Tab. 28: con.17 encoder cable pin assignment, EnDat 2.1 sin/cos

Length x [mm]	Diameter y [mm]
56	22

Tab. 29: con.17 connector dimensions

Encoder cables – con.23 plug connectors

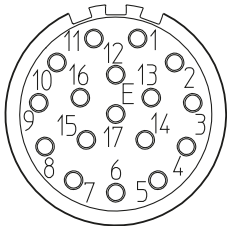
Connection diagram	Motor (1)		Cable (2)	Drive controller (3)
	Pin	Designation	Core color	Pin X140
	1	U ₂ Sense	GNRD	12
	2	—	—	—
	3	—	—	—
	4	0 V Sense	GNBK	10
	5	1TP2	BNGY	14
	6	1TP1	BNYE	7
	7	U ₂	BNRD	4
	8	Clock +	WHBK	8
	9	Clock -	WHYE	15
	10	0 V GND	BNBU	2
	11	—	—	—
	12	B + (Sin +)	RD	9
	13	B - (Sin -)	OG	1
	14	Data +	GY	5
	15	A + (Cos +)	GN	11
	16	A - (Cos -)	YE	3
	17	Data -	BU	13
Housing	Shield	—	Housing	

Tab. 30: con.23 encoder cable pin assignment, EnDat 2.1 sin/cos

Length x [mm]	Diameter y [mm]
58	26

Tab. 31: con.23 plug dimensions

6.1.5.2 AP6 interface adapter (EnDat 2.1 sin/cos)

AP6A02 – EnDat 2.1 sin/cos encoder (15-pin to 15-pin)

Interface adapter with temperature sensor cores led out at the side (core length: approx. 11 cm) for connecting the encoder cable to the drive controller.

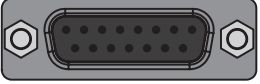
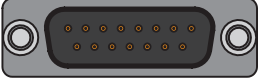
Socket ¹⁴	Pin	Designation	Function	Pin	Connector ¹⁵
 8 7 6 5 4 3 2 1 15 14 13 12 11 10 9	1	B – (Sin –)	Reference potential for sin input	1	 1 2 3 4 5 6 7 8 9 10 11 12 13 14 15
	2	0 V GND	Reference potential for encoder supply	2	
	3	A – (Cos –)	Reference potential for cos input	3	
	4	U ₂	Encoder supply	4	
	5	Data +	Differential input for DATA	5	
	6	—	—	6	
	7	1TP1	Motor temperature sensor connection, if included in the encoder cable; routed out for the direct connection to X2	—	
	8	Clock +	Differential input for CLOCK	8	
	9	B + (Sin +)	Sin input	9	
	10	0 V Sense	Optional reference potential of the Sense connection for regulating the encoder supply	10	
	11	A + (Cos +)	Cos input	11	
	12	U ₂ Sense	Sense signals for voltage excitation	12	
	13	Data –	Inverse differential input for DATA	13	
	14	1TP2	Motor temperature sensor connection, if included in the encoder cable; routed out for the direct connection to X2	—	
	15	Clock –	Inverse differential input for CLOCK	15	

Tab. 32: AP6A02 connection description for EnDat 2.1 sin/cos encoder and motor temperature sensor (15-pin to 15-pin)

¹⁴View of 15-pin D-sub for connecting the SDS 4000-compatible EnDat cable

¹⁵View of 15-pin D-sub for connecting to SD6, terminal X140 (RI6)

6.1.5.3 Technical data

IP protection class of the plug connectors

The plug connectors meet the IP 66/67 protection class (in accordance with IEC 60529). This information applies if both parts of the plug connector are connected together properly. Plug connectors have to be protected against environmental factors that affect functionality (dust, moisture, etc.) in accordance with the type approval laws.

Conductor design

Flexible, bare copper; all elements mounted in a round design at optimum length with filler

Peak operating voltage

- Peak operating voltage (DIN VDE): max. 100 V
- Voltage (UL/CSA): 30 V

Test voltage

Core/core and core/shield: 500 V × 1 min

Limit temperature

Temperature range by operating mode	DIN VDE	UL/CSA
Permanently installed	-50 °C to +90 °C	Up to +80 °C
Free to move	-40 °C to +90 °C	Up to +80 °C

Tensile stress when being laid

- Free to move: 20 N per mm² conductor cross-section
- Permanently installed: 50 N per mm² conductor cross-section

Smallest permissible bending radius

- Freely movable: 10 x d_{out}
- Permanently installed: 5 x d_{out}

Torsional stress

± 30°/m

Bending resistance

Trailable with 5 million bending cycles at a travel velocity of 180 m/min and an acceleration of 5 m/s² under optimum ambient conditions

Resistance

- Oil-resistant: in accordance with EN 50363-10-2
- Chemical: UV-resistant in accordance with EN 50289-4-17, hydrolysis-resistant in accordance with EN 50396, microbacteria-resistant

Outer sheath

PUR

Banding

Fleece tape with overlapping

Core insulation

PP

Core identification

Pair	Colors	
2 × 0.14	GN	YE
2 × 0.14	RD	OG
2 × 0.14	BU	GY
2 × 0.14	WHBK	WHYE
2 × 0.25	GNRD	GNBK
2 × 0.25	BNGY	BNYE
2 × 0.34	BNRD	BNBU

Sheath identification

Yellow-green color (similar to RAL 6018) imprinted with STOBER and No. "5050704"

Shield design

- Copper braid, tin-plated
- Cover: ≥ 80%

Insulation material

Halogen-free in accordance with EN 60754-1, silicone-free, CFC-free, free from paint-wetting impairment substances (PWIS)

Flammability

Combustion behavior: flame retardant and self-extinguishing in accordance with IEC 60332-1-2, UL/CSA FT1, CSA FT2, UL VW-1

RoHS conformity

Free of hazardous substances in accordance with the RoHS-2 Directive 2011/65/EU and RoHS-3 Directive 2015/863

Conductor cross-sections

Cable diameter	Description	Weight	ID No. (non-terminated cable)	
			New	Previously
Max. 8.7 mm	$(2 \times 2 \times 0.25 \text{ mm}^2 + 2 \times 2 \times 0.14 \text{ mm}^2 + 2 \times (2 \times 0.14 \text{ mm}^2) + 2 \times 0.34 \text{ mm}^2)$	87 g/m	5050704	44207

"(...)" = Shield

Design

UL/CSA (E172204, E170315 or E356538); for UL file number, see cable imprint

Capacitance, inductance, DC resistance

Operating capacitance in accordance with EN 50395 clause 8.1	
Pair 0.14 mm ²	Max. 150 nF/km
Pair 0.25 mm ²	Max. 150 nF/km
Pair 0.34 mm ²	Max. 150 nF/km

Inductance in accordance with EN 50289-1-12	
Pair 0.14 mm ²	Max. 0.8 mH/km
Pair 0.25 mm ²	Max. 0.8 mH/km
Pair 0.34 mm ²	Max. 0.8 mH/km

DC resistance at 20 °C	
Pair 0.14 mm ²	139.3 Ω/km
Pair 0.25 mm ²	78.0 Ω/km
Pair 0.34 mm ²	57.4 Ω/km

6.1.6 EnDat 3 or HIPERFACE DSL encoders**Information**

In combination with an EnDat 3 or HIPERFACE DSL encoder, you require hybrid cables which feature encoder communication and power transmission in a shared cable. STOBER OCS hybrid cables were specially developed for use in cable carriers with cable lengths up to 100 m. With line lengths up to 50 m, they can also be used in dynamic applications without an additional output choke.

For more information on motor connection using a hybrid cable, see [One Cable Solution \[► 102\]](#).

6.2 Determining the cable code for ready-made cables

The motor model, encoder model and encoder interface of the drive controller provide you with the cable code, which you in turn can use to determine the identification numbers of ready-made cables.

Information

Note that the cable codes used in this documentation are intended only to refer to the overview and selection tables within this manual. The cable codes are not part of the ordering process and are not printed on the cables.

6.2.1 Codes for EZ, EZHD, EZHP, EZS, EZM synchronous servo motors

The size of the motor plug connector of EZ, EZHD, EZM or EZS series synchronous servo motors depends on the size of the motor:

- con.15 for motors of sizes 2 to 3
- con.17 for motors of size 4 or larger

The encoder interface for connecting the cable varies based on the encoder model and drive controller series.

Cables

Type		EnDat 2.1/2.2 digital		Resolvers		EnDat 2.1 sin/cos	
		con.15	con.17	con.15	con.17	con.15	con.17
MDS 5000, SDS 5000, SB6, SD6	X4	<u>SZ7</u>	<u>SZ2</u>	—	—	—	—
MDS 5000, SDS 5000	X140	—	—	<u>SZ8</u>	<u>SZ1</u>	<u>SZ9</u>	<u>SZ3</u>
SB6, SD6	X140	<u>SZ7</u>	<u>SZ2</u>	<u>SZ8</u>	<u>SZ1</u>	<u>SZ9</u>	<u>SZ3</u>
SC6, SI6	X4	<u>SZ7</u>	<u>SZ2</u>	<u>SZ8</u>	<u>SZ1</u>	—	—

Tab. 33: Encoder cable codes for EZ, EZHD, EZM and EZS synchronous servo motors

Extension cables

Type		EnDat 2.1/2.2 digital		Resolvers		EnDat 2.1 sin/cos	
		con.15	con.17	con.15	con.17	con.15	con.17
All series		<u>SZ10</u>	<u>SZ5</u>	<u>SZ11</u>	<u>SZ4</u>	<u>SZ12</u>	<u>SZ13</u>

Tab. 34: Extension cable codes for EZ, EZHD, EZM and EZS synchronous servo motors

6.2.2 Codes for ED, EK synchronous servo motors

ED and EK series synchronous servo motors are equipped with size con.23 motor plug connectors.

The encoder interface for connecting the cable varies based on the encoder model and drive controller series.

Cables

Type		EnDat 2.1/2.2 digital	Resolvers	EnDat 2.1 sin/cos
		con.23	con.23	con.23
MDS 5000, SDS 5000, SB6, SD6	X4	<u>SK4</u>	—	—
	X140	—	<u>SK2</u>	<u>SK1</u>
SC6, SI6	X4	<u>SK4</u>	<u>SK2</u>	—

Tab. 35: Encoder cable codes for ED and EK synchronous servo motors

Information

For connecting con.23 resolver cables with a 9-pin D-sub connector, such as the standard design for ED/EK synchronous servo motors, you must use interface adapter AP6A00 (ID No. 56498) or AP6A01 (ID No. 56522, with motor temperature sensor leads), available separately.

Extension cables

Type		EnDat 2.1/2.2 digital	Resolvers	EnDat 2.1 sin/cos
		con.23	con.23	con.23
All series		<u>SK9</u>	<u>SKF</u>	<u>SKG</u>

Tab. 36: Extension cable codes for ED and EK synchronous servo motors

6.2.3 Codes for IE2, IE3 asynchronous motors

IE2 and IE3 series asynchronous motors are equipped with size con.23 motor plug connectors.

The available cables are connected to the X4 encoder interface of the drive controller.

Cables

Type		Incremental HTL	SSI
		con.23	con.23
FDS 5000	X4	<u>SK0</u>	—
MDS 5000, SDS 5000	X4	<u>SK0</u>	<u>SK4</u>
SB6, SD6	X4	<u>SK0</u>	<u>SK4</u>
SC6, SI6 ¹⁶	X4	<u>SK0</u>	<u>SK4</u>

Tab. 37: Encoder cable codes for IE2, IE3 asynchronous motors

Extension cables

Type		Incremental HTL	SSI
		con.23	con.23
All series		—	<u>SK9</u>

Tab. 38: Extension cable codes for IE2, IE3 asynchronous motors

¹⁶ HTL to TTL adapter required

6.3 Ready-made encoder cables

The cable code provides you with the identification numbers for ready-made cables up to 100 m in length.

Information

Note that the maximum overall length of the cable and extension is 100 m.

EnDat 2.1/2.2 digital – Cables

Code	Size	Cable length [m]																	
		2.5	5	7.5	10	12.5	15	18	20	25	30	35	40	50	60	70	80	90	100
SZ7	con.15	56737	56738	56739	56740	56741	56742	56743	56744	56745	56746	56747	56748	56749	56750	56751	56752	56753	56754
SZ2	con.17	54781	54782	54783	54784	54785	54786	54787	54788	54789	54790	54791	54792	54793	54794	54795	54796	54797	54798
SK4	con.23	54430	54431	54432	54433	54434	54435	54436	54437	54438	54439	54440	54441	54442	54443	54444	54445	54446	54447

Tab. 39: Ready-made cables up to 100 m for EnDat 2.1/2.2 digital encoders

EnDat 2.1/2.2 digital – Extension cables

Code	Size	Cable length [m]																	
		2.5	5	7.5	10	12.5	15	18	20	25	30	35	40	50	60	70	80	90	100
SZ10	con.15	57640	57641	57642	57643	57644	57645	57646	57647	57648	57649	57650	57651	57652	57653	57654	57655	57656	57657
SZ5	con.17	53506	53507	53508	53509	53510	53511	53512	53513	53514	53515	53516	53517	53518	53519	53520	53521	53522	53523
SK9	con.23	54527	54528	54529	54530	54531	54532	54533	54534	54535	54536	54537	54538	54539	54540	54541	54542	54543	54544

Tab. 40: Ready-made extension cables up to 100 m for EnDat 2.1/2.2 digital encoders

Incremental HTL – Cables

Code	Size	Cable length [m]																	
		2.5	5	7.5	10	12.5	15	18	20	25	30	35	40	50	60	70	80	90	100
SK0	con.23	54743	54744	54745	54746	54747	54748	54749	54750	54751	54752	54753	54754	54755	54756	54757	54758	54759	54760

Tab. 41: Ready-made cables up to 100 m for HTL incremental encoders

Resolver – Cables

Code	Size	Cable length [m]																	
		2.5	5	7.5	10	12.5	15	18	20	25	30	35	40	50	60	70	80	90	100
SZ8	con.15	56959	56960	56961	56962	56963	56964	56965	56966	56967	56968	56969	56970	56971	56972	56973	56974	56975	56976
SZ1	con.17	54817	54818	54819	54820	54821	54822	54823	54824	54825	54826	54827	54828	54829	54830	54831	54832	54833	54834
SK2	con.23	54184	54185	54186	54187	54188	54189	54190	54191	54192	54193	54194	54195	54196	54197	54198	54199	54200	54201

Tab. 42: Ready-made cables up to 100 m for resolvers

Resolver – Extension cables

Code	Size	Cable length [m]																	
		2.5	5	7.5	10	12.5	15	18	20	25	30	35	40	50	60	70	80	90	100
SZ11	con.15	57658	57659	57660	57661	57662	57663	57664	57665	57666	57667	57668	57669	57670	57671	57672	57673	57674	57675
SZ4	con.17	55928	55929	55930	55931	55932	55933	55934	55935	55936	55937	55938	55939	55940	55941	55942	55943	55944	55945
SKF	con.23	54276	54277	54278	54279	54280	54281	54282	54283	54284	54285	54286	54287	54288	54289	54290	54291	54292	54293

Tab. 43: Ready-made extension cables up to 100 m for resolvers

EnDat 2.1 sin/cos – Cables

Code	Size	Cable length [m]																	
		2.5	5	7.5	10	12.5	15	18	20	25	30	35	40	50	60	70	80	90	100
SZ9	con.15	56977	56978	56979	56980	56981	56982	56983	56984	56985	56986	56987	56988	56989	56990	56991	56992	56993	56994
SZ3	con.17	54799	54800	54801	54802	54803	54804	54805	54806	54807	54808	54809	54810	54811	54812	54813	54814	54815	54816
SK1	con.23	54100	54101	54102	54103	54104	54105	54106	54107	54108	54109	54110	54111	54112	54113	54114	54115	54116	54117

Tab. 44: Ready-made cables up to 100 m for EnDat 2.1 sin/cos encoders

EnDat 2.1 sin/cos – Extension cables

Code	Size	Cable length [m]																	
		2.5	5	7.5	10	12.5	15	18	20	25	30	35	40	50	60	70	80	90	100
SZ12	con.15	57676	57677	57678	57679	57680	57681	57682	57683	57684	57685	57686	57687	57688	57689	57690	57691	57692	57693
SZ13	con.17	57560	57561	57562	57563	57564	57565	57566	57567	57568	57569	57570	57571	57572	57573	57574	57575	57576	57577
SKG	con.23	54258	54259	54260	54261	54262	54263	54264	54265	54266	54267	54268	54269	54270	54271	54272	54273	54274	54275

Tab. 45: Ready-made extension cables up to 100 m for EnDat 2.1 sin/cos encoders

6.4 Service packs for encoder cables

If you would like to finish your cable yourself, you can find information in this chapter about available service packs. Our service packs contain the motor-side connector and the required contacts. To finish the contacts correctly, you require a suitable crimping tool for the respective contact type. More detailed information can be found in the enclosed assembly instructions.

Information

Be aware that the use of unsuitable cables or poorly made connections can cause subsequent damage. For this reason, we reserve the right to reject claims under the warranty in this case.

Type	con.15	con.17	con.23
EnDat 2.2 digital, 12-pin	57163	53791	55023 ^{a)}
Incremental (HTL), 12-pin	—	—	55023 ^{a)}
SSI, 12-pin	—	—	55023 ^{a)}
Resolver, 12-pin	57164	53791	55015
EnDat 2.1 sin/cos, 15-pin (con.15), 17-pin (con.17/con.23)	57162	53790	55018

Tab. 46: Identification numbers of service packs for encoder cables

a) Service pack contains appropriate crimp contacts for all 3 encoder models.

6.5 Accessories

You can find information about the available accessories in the following chapters.

6.5.1 HTL-to-TTL adapter

HT6 HTL-to-TTL adapter



ID No. 56665

Adapters for SC6 and SI6 series drive controllers for level conversion from HTL signals to TTL signals.

It is used to connect an HTL differential incremental encoder to terminal X4 of the drive controller.

6.5.2 Interface adapters

AP6 interface adapters



The following variants are available:

AP6A00

ID No. 56498

Adapter X140/X4 resolver, 9/15-pin.

Adapters for connecting resolver cables with a 9-pin D-sub connector.

SB6 series: Connection to the X140 encoder interface of the XB6 terminal module.

SC6 and SI6 series: Connection to the X4 encoder interface.

SD6 series: Connection to the X140 encoder interface of the RI6 terminal module.

AP6A01

ID No. 56522

Adapter X140 resolver, 9/15-pin with cores of the motor temperature sensor led out at the side (core length: approx. 11 cm).

Adapters for connecting resolver cables with a 9-pin D-sub connector.

SB6 series: Connection to the X140 encoder interface of the XB6 terminal module.

SC6 and SI6 series: Connection to the X4 encoder interface.

SD6 series: Connection to the X140 encoder interface of the RI6 terminal module.

AP6A02

ID No. 56523

Adapter X140 EnDat 2.1 sin/cos, 15/15-pin with cores of the motor temperature sensor led out at the side (core length: approx. 11 cm).

SD6 series: Connection to the X140 encoder interface of the RI6 terminal module.

6.5.3 Adapter cables

X50 adapter cable (SE6 option)



ID No. 56434

Adapter cable for the X50 encoder interface of the SE6 safety module with flying leads, length: 1.5 m.

6.5.4 Encoder battery module

Absolute Encoder Support AES



ID No. 55452

Battery module for buffering the supply voltage when using the EnDat 2.2 digital inductive encoder with battery-buffered multi-turn stage, for example EBI 1135 or EBI 135.

A battery is included.

Information

Note that a 15-pin extension cable between the socket and the AES may be necessary for the connection to the drive controller due to limited space.

A commercially available shielded extension cable with a 15-pin D-sub connector and a length of ≤ 1 m can be used between the socket and the AES.

AES replacement battery



ID No. 55453

Replacement battery for AES battery module.

6.5.5 Encoder adapter box

LA6A00 encoder adapter box



ID No. 56510

Interface adapter for differential TTL incremental signals and single-ended TTL Hall sensor signals.

The adapter converts and transmits TTL signals from synchronous linear motors to the SD6 drive controller. A variable, internal interface converts the input signals appropriately for the STOBER standard interfaces.

X120 SSI/TTL connecting cable



ID No. 49482

Cable for connecting the X120 interface for TTL incremental signals and SSI signals. Can be used in conjunction with the RI6 and XI6 G5 terminal modules, the SB6 XB6 terminal module and the X301 interface of the LA6 adapter box, length: 0.3 m.

LA6 / AX 5000 connecting cable



Cable for connecting the X4 connection on the SD6 drive controller to X300 on the LA6 adapter box in order to transmit incremental encoder signals.

The following designs are available:

ID No. 45405: 0.5 m.

ID No. 45386: 2.5 m.

6.5.6 Axis switcher

POSISwitch AX 5000 4-way axis switcher



ID No. 49578

Axis switcher for MDS 5000 and SDS 5000 series inverters.

Enables the operation of up to four synchronous servo motors on one inverter.

LA6 / AX 5000 connection cable



Cable to connect inverter and POSISwitch AX 5000 axis switcher.

The following versions are available:

ID No. 45405: 0.5 m.

ID No. 45386: 2.5 m.

7 Power cables

The synchronous servo motors and Lean motors are equipped with plug connectors as standard, while asynchronous motors are equipped with terminal boxes.

STOBER provides suitable cables in various lengths, conductor cross-sections and connector sizes.

7.1 Connection description

Depending on the size of the motor plug connector, power cables are available in the following designs:

- Quick-lock for con.15
- speedtec quick-lock for con.23 and con.40
- Screw technology for con.58

Information

Observe the designations on the identification clips for the correct connection of the cores.

Motor-side connection

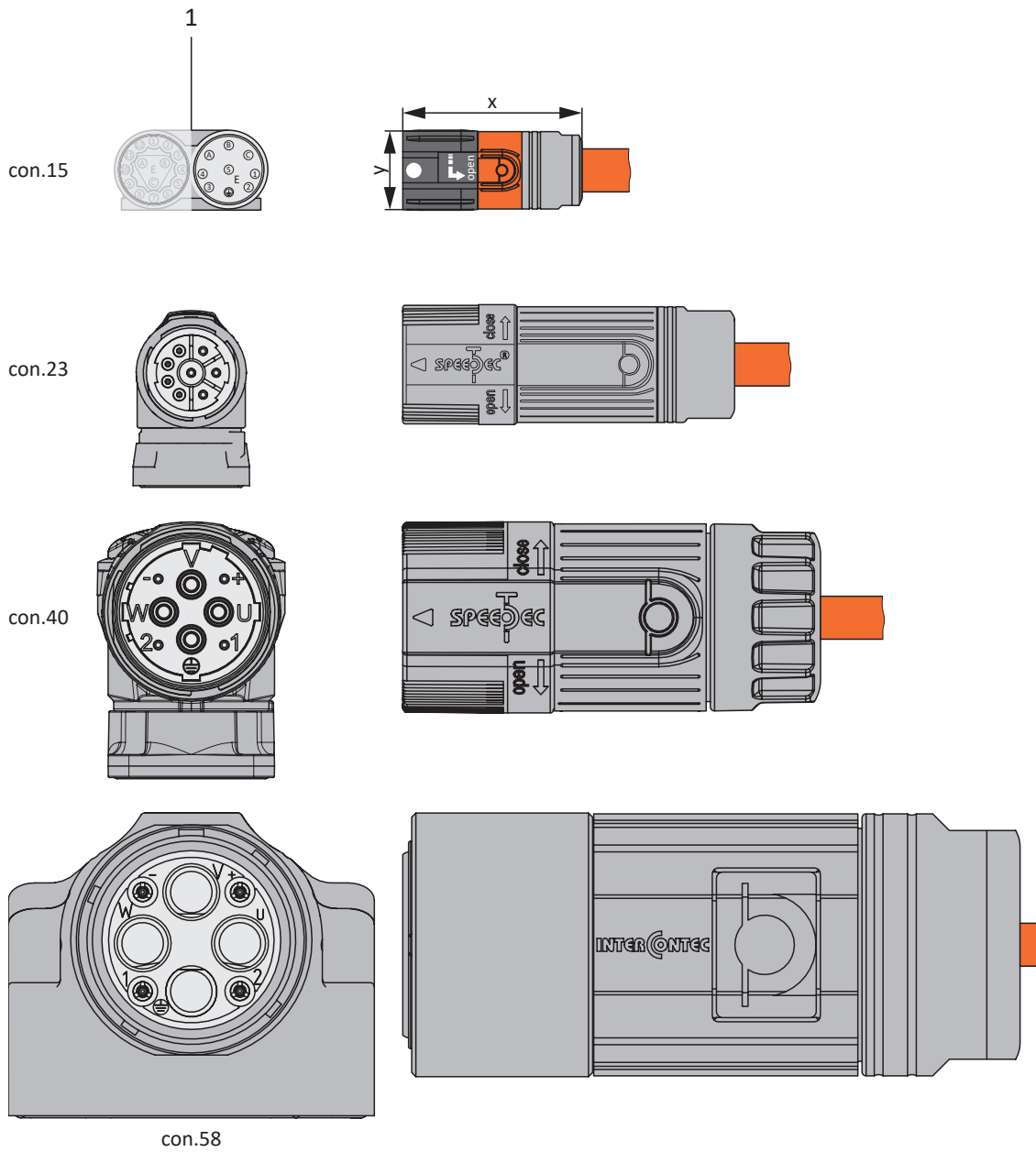

1 Plug connectors

Drive controller-side connection for the SC6 and SI6 series

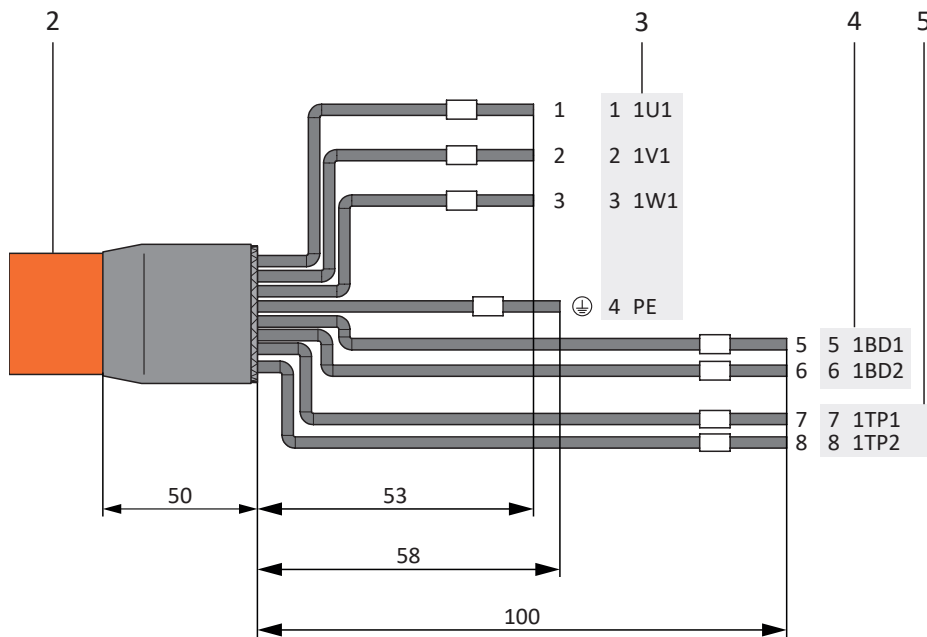

- 2 Power cable with cable shield
- 3 Connection to terminal X20, motor
- 4 Connection of terminal X2, brake
- 5 Connection to terminal X2, temperature sensor

Drive controller-side connection for the MDS 5000, SDS 5000 and SD6 series

Sizes 0 to 2

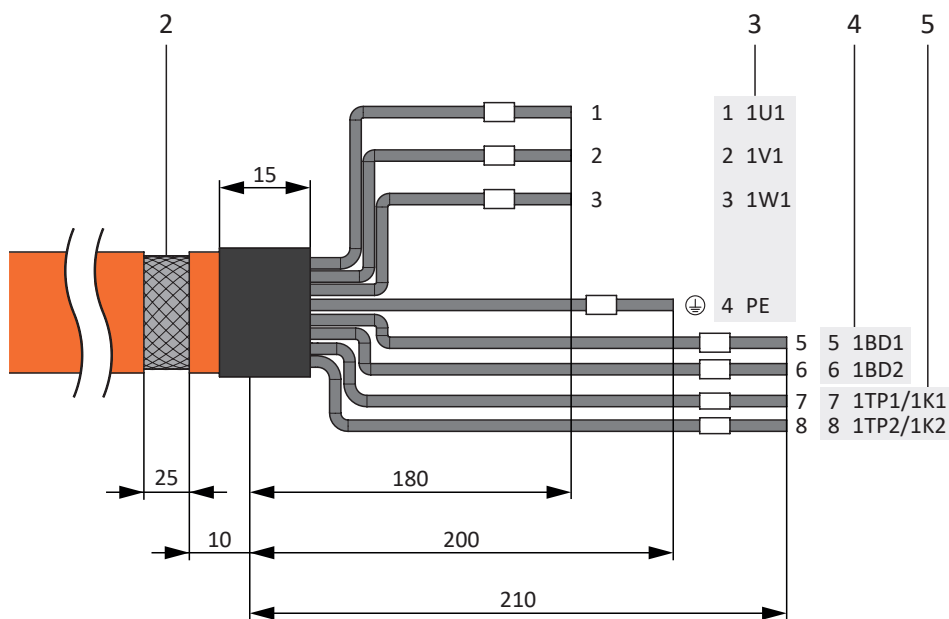

Size 3

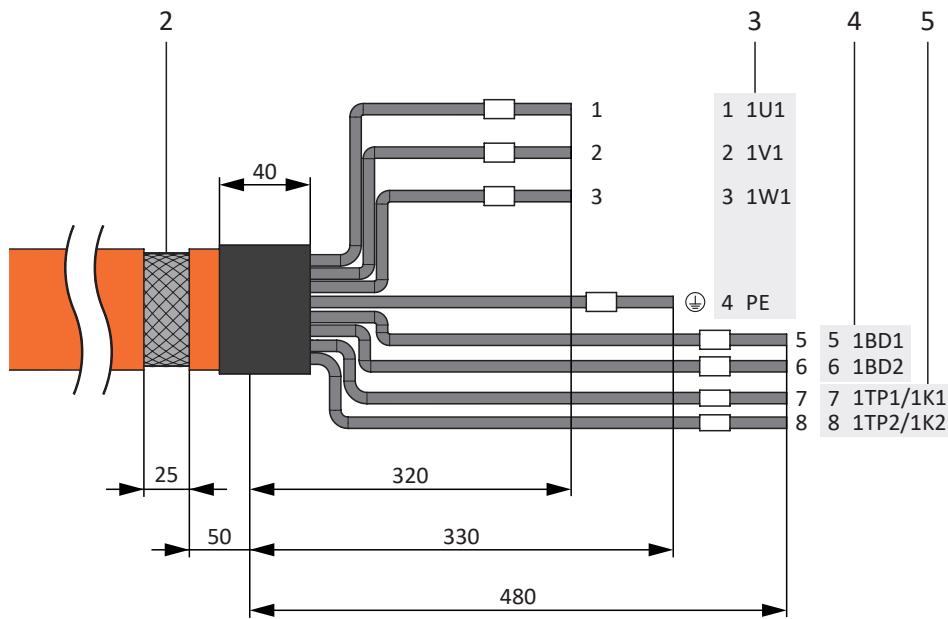

- 2 Power cable with cable shield and shrink tube
- 3 Connection to terminal X20, motor
- 4 Connection of terminal X5, brake
- 5 Connection to terminal X2, temperature sensor

Maximum cable length

Motor type	Connection	Size 0 to 2	Size 3
Synchronous servo motor, asynchronous motor	Without output choke	50 m, shielded	100 m, shielded
Synchronous servo motor, asynchronous motor	With output choke	100 m, shielded	—
Lean motor	Without output choke	50 m, shielded ^{a)}	50 m, shielded ^{a)}

Tab. 47: Maximum cable length of the power cable [m]

a) The use of cables with a length greater than 50 m and up to maximum 100 m must be checked by STOBER for the application.

Power cables – con.15 plug connector

Motor connection diagram	Motor (1)		Cable (2)	Drive controller (3) – (5)		
	Pin	Designation	Identification/ Core color	Pin X20	Pin X2/X5	Pin X2
	A	1U1	1	1	—	—
	B	1V1	2	2	—	—
	C	1W1	3	3	—	—
	1	1TP1/1K1	7	—	—	7
	2	1TP2/1K2	8	—	—	8
	3	1BD1	5	—	5	—
	4	1BD2	6	—	6	—
	5	—	—	—	—	—
		PE	GNYE	4	—	—
	Housing	Shield	—	Shield contact	—	—

Tab. 48: con.15 power cable pin assignment

Length x [mm]	Diameter y [mm]
42	18.7

Tab. 49: con.15 connector dimensions

Power cables – con.23 plug connector

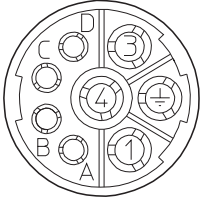
Motor connection diagram	Motor (1)		Cable (2)	Drive controller (3) – (5)		
	Pin	Designation	Identification/ Core color	Pin X20	Pin X2/X5	Pin X2
	1	1U1	1	1	—	—
	3	1V1	2	2	—	—
	4	1W1	3	3	—	—
	A	1BD1	5	—	5	—
	B	1BD2	6	—	6	—
	C	1TP1/1K1	7	—	—	7
	D	1TP2/1K2	8	—	—	8
	⊕	PE	GNYE	4	—	—
	Housing	Shield	—	Shield contact	—	—

Tab. 50: con.23 power cable pin assignment

Length x [mm]	Diameter y [mm]
78	26

Tab. 51: con.23 connector dimensions

Power cables – con.40 plug connector

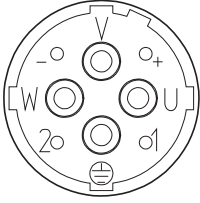
Motor connection diagram	Motor (1)		Cable (2)	Drive controller (3) – (5)		
	Pin	Designation	Identification/ Core color	Pin X20	Pin X2/X5	Pin X2
	U	1U1	1	1	—	—
	V	1V1	2	2	—	—
	W	1W1	3	3	—	—
	+	1BD1	5	—	5	—
	-	1BD2	6	—	6	—
	1	1TP1/1K1	7	—	—	7
	2	1TP2/1K2	8	—	—	8
	⊕	PE	GNYE	4	—	—
	Housing	Shield	—	Shield contact	—	—

Tab. 52: con.40 power cable pin assignment

Length x [mm]	Diameter y [mm]
99	46

Tab. 53: con.40 connector dimensions

Power cables – con.58 plug connectors

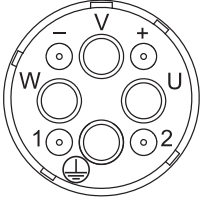
Motor connection diagram	Motor (1)		Cable (2)	Drive controller (3) – (5)		
	Pin	Designation	Identification/ Core color	Pin X20	Pin X2/X5	Pin X2
	U	1U1	1	1	—	—
	V	1V1	2	2	—	—
	W	1W1	3	3	—	—
	+	1BD1	5	—	5	—
	-	1BD2	6	—	6	—
	1	1TP1/1K1	7	—	—	7
	2	1TP2/1K2	8	—	—	8
	⊕	PE	GNYE	4	—	—
	Housing	Shield	—	Shield contact	—	—

Tab. 54: con.58 power cable pin assignment

Length x [mm]	Diameter y [mm]
146	63.5

Tab. 55: con.58 connector dimensions

7.2 Technical data

IP protection class of the plug connectors

The plug connectors meet the IP 66/67 protection class (in accordance with IEC 60529). This information applies if both parts of the plug connector are connected together properly. Plug connectors have to be protected against environmental factors that affect functionality (dust, moisture, etc.) in accordance with the type approval laws.

Conductor design

Conductor cross-section $4 \times 1.0 \text{ mm}^2$ to $4 \times 16.0 \text{ mm}^2$

Flexible, bare copper; all elements mounted in a round design with filler

Conductor cross-section $4 \times 25.0 \text{ mm}^2$

Bare copper, class 6 in accordance with DIN EN 60228; 4 cores and 2 pairs with filling elements twisted around the center

Voltage

Conductor cross-section $4 \times 1.0 \text{ mm}^2$ to $4 \times 16.0 \text{ mm}^2$

- Nominal voltage (DIN VDE): power cores $U_o/U = 0.6/1.0 \text{ kV}$
- Peak operating voltage (DIN VDE): pilot cores max. 350 V
- Voltage (UL/CSA): power cores 1000 V
- Voltage (UL/CSA): pilot cores 1000 V

Conductor cross-section $4 \times 25.0 \text{ mm}^2$

- Nominal voltage (DIN VDE): power cores $U_o/U = 0.6/1.0 \text{ kV}$
- Nominal voltage (DIN VDE): pilot cores $U_o/U = 300/500 \text{ V}$
- Voltage (UL/CSA): power cores 1000 V
- Voltage (UL/CSA): pilot cores 1000 V

Test voltage

Conductor cross-section $4 \times 1.0 \text{ mm}^2$ to $4 \times 1.5 \text{ mm}^2$

- Core/core and core/shield: power cores 4000 V \times 5 min
- Core/core and core/shield: pilot cores 2000 V \times 5 min

Conductor cross-section $4 \times 2.5 \text{ mm}^2$ to $4 \times 25.0 \text{ mm}^2$

- Core/core and core/shield: power cores 4000 V \times 5 min
- Core/core and core/shield: pilot cores 4000 V \times 5 min

Current carrying capacity

Conductor cross-section $4 \times 1.0 \text{ mm}^2$ to $4 \times 4.0 \text{ mm}^2$

Power cores in accordance with DIN VDE 0298, part 4, tables 11 and 17; pilot cores in accordance with DIN VDE 0891, part 1

Conductor cross-section $4 \times 10.0 \text{ mm}^2$ to $4 \times 25.0 \text{ mm}^2$

Power and pilot cores in accordance with DIN VDE 0298, part 4, tables 11 and 17

Power cores							
Conductor cross-section [mm ²]	1.0	1.5	2.5	4.0	10.0	16.0	25.0
Nominal current $I_{N,CAB}$ [A]	13.1	15.7	22.6	29.6	53.0	71.0	94.0

Pilot cores – Brake and temperature sensor					
Conductor cross-section [mm ²]	0.34	0.5	0.75	1.0	1.5
Nominal current $I_{N,CAB}$ [A]	4.4	7.8	10.4	13.1	15.7

Limit temperature

Temperature range by operating mode	DIN VDE	UL/CSA
Permanently installed	-50 °C to +90 °C	Up to +80 °C
Free to move	-40 °C to +90 °C; from $4 \times 16.0 \text{ mm}^2$: -30 °C to +80 °C	Up to +80 °C

Tensile stress when being laid

- Free to move: 20 N per mm² conductor cross-section
- Permanently installed: 50 N per mm² conductor cross-section

Smallest permissible bending radius

Routing method	$4 \times 1.0 \text{ mm}^2$ to $4 \times 10.0 \text{ mm}^2$	$4 \times 16.0 \text{ mm}^2$ to $4 \times 25.0 \text{ mm}^2$
Freely movable	$10 \times d_{out}$	$7.5 \times d_{out}$
Permanently installed	$5 \times d_{out}$	$4 \times d_{out}$

Torsional stress

$\pm 30^\circ/\text{m}$

Bending resistance

Trailable with 5 million bending cycles at a travel velocity of 180 m/min and an acceleration of 5 m/s^2 under optimum ambient conditions

Resistance

Conductor cross-section $4 \times 1.0 \text{ mm}^2$ to $4 \times 16.0 \text{ mm}^2$

- Oil-resistant: in accordance with EN 50363-10-2
- Chemical: UV-resistant in accordance with EN 50289-4-17, hydrolysis-resistant in accordance with EN 50396, microbacteria-resistant

Conductor cross-section $4 \times 25.0 \text{ mm}^2$

- Oil-resistant: in accordance with EN 50363-10-2 and EN 60811-2-1
- Chemical: resistant to acids, alkalis, cleaning agents, and dusts

Outer sheath

PUR

Banding

Fleece tape with overlapping

Core insulation

PP

Core identification

Conductor cross-section $4 \times 1.0 \text{ mm}^2$

Power cores: black color with printed numbers (1, 2, 3); yellow-green for grounding conductor; pilot cores: white color with printed numbers (5, 6 and 7, 8); cores with core clips

Conductor cross-section $4 \times 1.5 \text{ mm}^2$

Power cores: black color with printed numbers (1, 2, 3); yellow-green for grounding conductor; pilot cores: black color with printed numbers (5, 6 and 7, 8); cores with core clips

Conductor cross-section $4 \times 2.5 \text{ mm}^2$ to $4 \times 25.0 \text{ mm}^2$

Power cores: black color with printed numbers (U/L1/C/L+, V/L2/, W/L3/D/L-); yellow-green for grounding conductor; pilot cores: black color with printed numbers (5, 6 and 7, 8); cores with core clips

Sheath identification

Conductor cross-section $4 \times 1.0 \text{ mm}^2$ to $4 \times 1.5 \text{ mm}^2$

Orange color (similar to RAL 2003) imprinted with STOBER and number (1.0 mm²: "5050042"; 1.5 mm²: "5050043")

Conductor cross-section $4 \times 2.5 \text{ mm}^2$ to $4 \times 25.0 \text{ mm}^2$

Orange color (similar to RAL 2003) with imprint of cable manufacturer

Shield coverage factor

Braiding made of tin-plated copper wires, cover $\geq 85\%$

Insulation material

Halogen-free in accordance with EN 60754-1, silicone-free, CFC-free, free from paint-wetting impairment substances (PWIS)

Flammability**Conductor cross-section $4 \times 1.0 \text{ mm}^2$ to $4 \times 16.0 \text{ mm}^2$**

Combustion behavior: flame retardant and self-extinguishing in accordance with IEC 60332-1-2, UL/CSA FT1, UL VW-1

Conductor cross-section $4 \times 25.0 \text{ mm}^2$

Combustion behavior: flame retardant and self-extinguishing in accordance with IEC 60332-1-2, UL758 cable flame test

RoHS conformity

Free of hazardous substances in accordance with the RoHS-2 Directive 2011/65/EU and RoHS-3 Directive 2015/863

Conductor cross-sections and weights

Cable diameter	Description	Weight	ID No. (non-terminated cable)	
			New	Previously
Max. 10.1 mm	$(4 \times 1.0 + (2 \times 0.5) + (2 \times 0.34)) \text{ mm}^2$	0.215 kg/m	5050042	49893
Max. 12.2 mm	$(4 \times 1.5 + (2 \times 1.0) + (2 \times 0.50)) \text{ mm}^2$	0.285 kg/m	5050043	44211
Max. 15.1 mm	$(4 \times 2.5 + 2 \times (2 \times 1.0)) \text{ mm}^2$	0.320 kg/m	5052329	44210
Max. 16.8 mm	$(4 \times 4.0 + (2 \times 1.5) + (2 \times 1.0)) \text{ mm}^2$	0.430 kg/m	5052330	45801
Max. 19.4 mm	$(4 \times 6.0 + (2 \times 1.5) + (2 \times 1.0)) \text{ mm}^2$	0.585 kg/m	5052331	45802
Max. 22.3 mm	$(4 \times 10.0 + (2 \times 1.5) + (2 \times 1.0)) \text{ mm}^2$	0.805 kg/m	5052332	45803
Max. 25.0 mm	$(4 \times 16.0 + 2 \times (2 \times 1.5)) \text{ mm}^2$	1.150 kg/m	53178	
Max. 27.5 mm	$(4 \times 25.0 + 2 \times (2 \times 1.5)) \text{ mm}^2$	1.478 kg/m	53234	

"(...)" = shield; other cross-sections on request

End sleeves

End sleeves in accordance with DIN 46228-4		
Conductor cross-section [mm^2]	0.34 – 1.5	2.5 – 25.0
Contact length [mm]	10	18

Design

UL/CSA (E172204, E170315 or E356538); for UL file number, see cable imprint

Capacitance, inductance, DC resistance

Operating capacitance in accordance with EN 50395 clause 8.1	
Conductor cross-section 4 × 1.0 mm²	
Cores 1.0 mm ²	Max. 200 nF/km
Pair 0.5 mm ²	Max. 200 nF/km
Pair 0.34 mm ²	Max. 185 nF/km
Conductor cross-section 4 × 1.5 mm²	
Cores 1.5 mm ²	Max. 200 nF/km
Pair 1.0 mm ²	Max. 200 nF/km
Pair 0.5 mm ²	Max. 200 nF/km
Conductor cross-section 4 × 2.5 mm²	
Cores 2.5 mm ²	Max. 200 nF/km
Pair 1.0 mm ²	Max. 200 nF/km
Conductor cross-section 4 × 4.0 mm²	
Cores 4.0 mm ²	On request
Pair 1.0 mm ²	On request
Pair 1.5 mm ²	On request
Conductor cross-section 4 × 10.0 mm²	
Cores 10.0 mm ²	Max. 210 nF/km
Pair 1.0 mm ²	Max. 210 nF/km
Pair 1.5 mm ²	Max. 262 nF/km
Conductor cross-section 4 × 16.0 mm²	
Cores 16.0 mm ²	Max. 265 nF/km
Pair 1.5 mm ²	Max. 262 nF/km
Conductor cross-section 4 × 25.0 mm²	
Cores 25.0 mm ²	Max. 235 nF/km
Pair 1.5 mm ²	Max. 180 nF/km

Inductance in accordance with EN 50289-1-12	
Conductor cross-section 4 × 1.0 mm²	
Cores 1.0 mm ²	Max. 0.7 mH/km
Pair 0.5 mm ²	Max. 0.7 mH/km
Pair 0.34 mm ²	Max. 0.7 mH/km
Conductor cross-section 4 × 1.5 mm²	
Cores 1.5 mm ²	Max. 0.7 mH/km
Pair 1.0 mm ²	Max. 0.7 mH/km
Pair 0.5 mm ²	Max. 0.7 mH/km
Conductor cross-section 4 × 2.5 mm²	
Cores 2.5 mm ²	Max. 0.7 mH/km
Pair 1.0 mm ²	Max. 0.7 mH/km
Conductor cross-section 4 × 4.0 mm²	
Cores 4.0 mm ²	Max. 0.7 mH/km
Pair 1.0 mm ²	Max. 0.7 mH/km
Pair 1.5 mm ²	Max. 0.7 mH/km
Conductor cross-section 4 × 10.0 mm²	
Cores 10.0 mm ²	Max. 0.7 mH/km
Pair 1.0 mm ²	Max. 0.7 mH/km
Pair 1.5 mm ²	Max. 0.7 mH/km
Conductor cross-section 4 × 16.0 mm²	
Cores 16.0 mm ²	Max. 0.7 mH/km
Pair 1.5 mm ²	Max. 0.7 mH/km
Conductor cross-section 4 × 25.0 mm²	
Cores 25.0 mm ²	Max. 0.38 mH/km
Pair 1.5 mm ²	Max. 0.32 mH/km

DC resistance at 20 °C	
Conductor cross-section 4 × 1.0 mm²	
Cores 1.0 mm ²	19.5 Ω/km
Pair 0.5 mm ²	39.0 Ω/km
Pair 0.34 mm ²	57.4 Ω/km
Conductor cross-section 4 × 1.5 mm²	
Cores 1.5 mm ²	13.3 Ω/km
Pair 1.0 mm ²	19.5 Ω/km
Pair 0.5 mm ²	39.0 Ω/km
Conductor cross-section 4 × 2.5 mm²	
Cores 2.5 mm ²	7.98 Ω/km
Pair 1.0 mm ²	19.5 Ω/km
Conductor cross-section 4 × 4.0 mm²	
Cores 4.0 mm ²	4.95 Ω/km
Pair 1.0 mm ²	19.5 Ω/km
Pair 1.5 mm ²	13.3 Ω/km
Conductor cross-section 4 × 10.0 mm²	
Cores 10.0 mm ²	1.91 Ω/km
Pair 1.0 mm ²	19.5 Ω/km
Pair 1.5 mm ²	13.3 Ω/km
Conductor cross-section 4 × 16.0 mm²	
Cores 16.0 mm ²	1.21 Ω/km
Pair 1.5 mm ²	13.3 Ω/km
Conductor cross-section 4 × 25.0 mm²	
Cores 25.0 mm ²	0.78 Ω/km
Pair 1.5 mm ²	13.3 Ω/km

7.3 Power cables for asynchronous motors

Proceed as follows:

- Determine the minimum cross-section of the cable based on the motor
- Check whether the minimum cross-section is sufficient for your application; adjust it if necessary
- The conductor cross-section then provides you with the identification numbers of the available non-terminated cables

7.3.1 Assignment of motor to minimum cross-section

Type	P _N [kW]	I _N [A]	1.5 mm ²	2.5 mm ²	4.0 mm ²	10.0 mm ²	16.0 mm ²	25.0 mm ²
IE3D063K04	0.12	0.35	✓					
IE3D063M04	0.18	0.55	✓					
IE3D071K04	0.25	0.66	✓					
IE3D071L04	0.37	0.98	✓					
IE3D080K04	0.55	1.27	✓					
IE3D080L04	0.75	1.70	✓					
IE3D090S04	1.10	2.50	✓					
IE3D090LX04	1.50	3.40	✓					
IE3D100KX04	2.20	4.55	✓					
IE3D100LX04	3.00	6.35	✓					
IE3D112M04	4.00	7.90	✓					
IE3D132SX04	5.50	10.0	✓					
IE3D132MX04	7.50	16.0		✓				
IE3D160MX04	11.0	21.0		✓				
IE3D160LX04	15.0	27.50			✓			
IE3D180MX04	18.50	34.50				✓		
IE3D180LX04	22.0	41.0				✓		
IE3D200LX04	30.0	54.0					✓	
IE3D225SX04	37.0	67.0						✓
IE3D225MX04	45.0	83.0						✓

Tab. 56: Assignment of asynchronous motor (4-pole) to minimum cross-section

7.3.2 Checking the minimum cross-section for non-terminated power cables

STOBER offers cables with a minimum cross-section for the motors as standard. Depending on the application, however, larger conductor cross-sections may be required. For this reason, take into account the following points in addition for dimensioning the cable:

Nominal current I_N of the motor

For designing the cable, note the nominal current I_N of the motor.

Permitted current carrying capacity of the conductors

Observe the permitted carrying capacity of the cable depending on the ambient and usage conditions. The following standards describe this topic:

- General requirements for machine cabling: EN 60204-1
- Detailed information: DIN VDE 0298-4

Cable length

Observe the length of the power and brake cores:

- The length of the power cores affects the possible short-circuit currents that have to be handled by the device protection
- The length of the brake cores can cause problems due to a voltage drop

Terminal specifications of the drive controller or output choke

The selected cable must be covered by the specification of the terminals of the drive controller or output choke (see [Terminal specifications \[► 118\]](#)).

Plug connector size of the motor

Depending on the plug connector size of the motor, different power core cross-sections are available.

Information

Select a larger conductor cross-section if required by your application.

7.3.3 Non-terminated power cables

The cable diameter and description provide you with the identification numbers for non-terminated cables up to 100 m in length.

Non-terminated cables are available by the meter (whole meters). Indicate the desired cable length when placing your order.

Information

For drive controllers of sizes 0 to 2, you also need an output choke for an overall length of 50 m or more in order to reduce interference pulses and protect the drive system. For drive controllers of sizes 0 to 2 with output chokes as well as drive controllers of size 3, the maximum overall length of the cable and extension is 100 m.

Cable diameter	Description	Weights	ID No. (non-terminated power cables)	
			New	Previously
Max. 10.1 mm	$(4 \times 1.0 + (2 \times 0.5) + (2 \times 0.34)) \text{ mm}^2$	0.215 kg/m	5050042	49893
Max. 12.2 mm	$(4 \times 1.5 + (2 \times 1.0) + (2 \times 0.50)) \text{ mm}^2$	0.285 kg/m	5050043	44211
Max. 15.1 mm	$(4 \times 2.5 + 2 \times (2 \times 1.0)) \text{ mm}^2$	0.320 kg/m	5052329	44210
Max. 16.8 mm	$(4 \times 4.0 + (2 \times 1.5) + (2 \times 1.0)) \text{ mm}^2$	0.430 kg/m	5052330	45801
Max. 19.4 mm	$(4 \times 6.0 + (2 \times 1.5) + (2 \times 1.0)) \text{ mm}^2$	0.585 kg/m	5052331	45802
Max. 22.3 mm	$(4 \times 10.0 + (2 \times 1.5) + (2 \times 1.0)) \text{ mm}^2$	0.805 kg/m	5052332	45803
Max. 25.0 mm	$(4 \times 16.0 + 2 \times (2 \times 1.5)) \text{ mm}^2$	1.150 kg/m	53178	
Max. 27.5 mm	$(4 \times 25.0 + 2 \times (2 \times 1.5)) \text{ mm}^2$	1.478 kg/m	53234	

Tab. 57: Non-terminated power cables up to 100 m

"(...)" = Shield

7.4 Power cables for synchronous motors

Proceed as follows:

- Determine the size of the plug connector and the minimum cross-section of the cable based on the motor
- Check whether the minimum cross-section is sufficient for your application; adjust it if necessary
- Determine the cable code based on the plug connector size and conductor cross-section, which you can use in turn to get the identification numbers of ready-made cables

7.4.1 Determining the cable code for ready-made cables in 3 steps

Information

Note that the cable codes used in this documentation are intended only to refer to the overview and selection tables within this manual. The cable codes are not part of the ordering process and are not printed on the cables.

7.4.1.1 Sizes for EZ, EZHD, EZHP, EZS, EZM synchronous servo motors

Determine the size of the plug connector and the minimum cross-section of the cable based on the motor.

EZ motors – IC 410 convection cooling

	n _N 2000 rpm				n _N 3000 rpm				n _N = 4000 rpm / 4500 rpm				n _N 6000 rpm			
	K _{EM} [V/1000 rpm]	I ₀ [A]	Plug con. size	Minimum cross- section [mm ²]	K _{EM} [V/1000 rpm]	I ₀ [A]	Plug con. size	Minimum cross- section [mm ²]	K _{EM} [V/1000 rpm]	I ₀ [A]	Plug con. size	Minimum cross- section [mm ²]	K _{EM} [V/1000 rpm]	I ₀ [A]	Plug con. size	Minimum cross- section [mm ²]
EZ202U	—	—	—	—	—	—	—	—	—	—	—	—	40	1.03	con.15	1.0
EZ203U	—	—	—	—	—	—	—	—	—	—	—	—	40	1.64	con.15	1.0
EZ301U	—	—	—	—	40	2.02	con.15	1.0	—	—	—	—	40	2.02	con.15	1.0
EZ302U	—	—	—	—	86	1.67	con.15	1.0	—	—	—	—	42	3.48	con.15	1.0
EZ303U	—	—	—	—	109	1.71	con.15	1.0	—	—	—	—	55	3.55	con.15	1.0
EZ401U	—	—	—	—	96	2.88	con.23	1.0 / 1.5	—	—	—	—	47	5.36	con.23	1.0 / 1.5
EZ402U	—	—	—	—	94	4.8	con.23	1.0 / 1.5	—	—	—	—	60	7.43	con.23	1.0 / 1.5
EZ404U	—	—	—	—	116	6.6	con.23	1.0 / 1.5	—	—	—	—	78	9.78	con.23	1.0 / 1.5
EZ501U	—	—	—	—	97	4	con.23	1.0 / 1.5	—	—	—	—	68	5.8	con.23	1.0 / 1.5
EZ502U	—	—	—	—	121	5.76	con.23	1.0 / 1.5	—	—	—	—	72	9.8	con.23	1.0 / 1.5
EZ503U	—	—	—	—	119	7.67	con.23	1.0 / 1.5	—	—	—	—	84	11.6	con.23	1.0 / 1.5
EZ505U	—	—	—	—	141	10	con.23	1.0 / 1.5	103	13.4	con.23	1.5	—	—	—	—
EZ701U	—	—	—	—	95	8	con.23	1.0 / 1.5	—	—	—	—	76	9.38	con.23	1.0 / 1.5
EZ702U	—	—	—	—	133	9.6	con.23	1.0 / 1.5	—	—	—	—	82	16.5	con.23	2.5
EZ703U	—	—	—	—	122	14	con.23	1.5	99	17.8	con.23	2.5	—	—	—	—
EZ705U	—	—	—	—	140	19.5	con.40	2.5	106	25.2	con.40	4.0	—	—	—	—
EZ802U	—	—	—	—	136	22.3	con.40	4.0	90	33.3	con.40	4.0/6.0	—	—	—	—
EZ803U	—	—	—	—	131	31.1	con.40	10.0	—	—	—	—	—	—	—	—

	n _N 2000 rpm				n _N 3000 rpm				n _N = 4000 rpm / 4500 rpm				n _N 6000 rpm			
EZ805U	142	37.9	con.40	10.0	—	—	—	—	—	—	—	—	—	—	—	—
	K _{EM} [V/1000 rpm]	I ₀ [A]	Plug con. size	Minimum cross- section [mm ²]	K _{EM} [V/1000 rpm]	I ₀ [A]	Plug con. size	Minimum cross- section [mm ²]	K _{EM} [V/1000 rpm]	I ₀ [A]	Plug con. size	Minimum cross- section [mm ²]	K _{EM} [V/1000 rpm]	I ₀ [A]	Plug con. size	Minimum cross- section [mm ²]
EZ813U	239	16.5	con.40	2.5	—	—	—	—	117	32.8	con.40	10.0	—	—	—	—
EZ815U	239	25.2	con.40	4.0	—	—	—	—	117	50.3	con.40	10.0	—	—	—	—

Tab. 58: Plug connector size and minimum cross-section, EZ synchronous servo motors with convection cooling

Minimum cross-section specification for motors with integrated holding brake: The smaller cross-section applies to cable lengths up to max. 12.5 m.

EZ motors – IC 416 forced ventilation

	n _N 2000 rpm				n _N 3000 rpm				n _N = 4000 rpm / 4500 rpm				n _N 6000 rpm			
	K _{EM} [V/1000 rpm]	I ₀ [A]	Plug con. size	Minimum cross- section [mm ²]	K _{EM} [V/1000 rpm]	I ₀ [A]	Plug con. size	Minimum cross- section [mm ²]	K _{EM} [V/1000 rpm]	I ₀ [A]	Plug con. size	Minimum cross- section [mm ²]	K _{EM} [V/1000 rpm]	I ₀ [A]	Plug con. size	Minimum cross- section [mm ²]
EZ401B	—	—	—	—	96	3.6	con.23	1.0 / 1.5	—	—	—	—	47	6.83	con.23	1.0 / 1.5
EZ402B	—	—	—	—	94	5.8	con.23	1.0 / 1.5	—	—	—	—	60	9.34	con.23	1.0 / 1.5
EZ404B	—	—	—	—	116	8.7	con.23	1.0 / 1.5	—	—	—	—	78	12	con.23	1.0 / 1.5
EZ501B	—	—	—	—	97	5	con.23	1.0 / 1.5	—	—	—	—	68	7.5	con.23	1.0 / 1.5
EZ502B	—	—	—	—	121	8.16	con.23	1.0 / 1.5	—	—	—	—	72	13.4	con.23	1.5
EZ503B	—	—	—	—	119	11.8	con.23	1.0 / 1.5	—	—	—	—	84	15.9	con.23	2.5
EZ505B	—	—	—	—	141	14.7	con.23	1.5	103	19.4	con.23	2.5	—	—	—	—
EZ701B	—	—	—	—	95	10	con.23	1.0 / 1.5	—	—	—	—	76	12.4	con.23	1.0 / 1.5
EZ702B	—	—	—	—	133	12.9	con.23	1.0 / 1.5	—	—	—	—	82	22.1	con.23	2.5 / 4.0
EZ703B	—	—	—	—	122	20	con.23	2.5	99	24.2	con.23	4.0	—	—	—	—
EZ705B	—	—	—	—	140	26.5	con.40	4.0	106	32.8	con.40	6.0	—	—	—	—
EZ802B	—	—	—	—	136	28.9	con.40	4.0 / 6.0	90	45.1	con.40	10.0	—	—	—	—
EZ803B	—	—	—	—	131	42.3	con.40	10.0	—	—	—	—	—	—	—	—
EZ805B	142	53.9	con.40	16.0	—	—	—	—	—	—	—	—	—	—	—	—
EZ813B	239	22.9	con.40	4.0	—	—	—	—	117	46.6	con.40	10.0	—	—	—	—
EZ815B	239	36.3	con.40	10.0	—	—	—	—	117	65.0	con.40	16.0	—	—	—	—

Tab. 59: Plug connector size and minimum cross-section, EZ synchronous servo motors with forced ventilation

Minimum cross-section specification for motors with integrated holding brake: The smaller cross-section applies to cable lengths up to max. 12.5 m.

EZHD motors – IC 410 convection cooling

	n _N 3000 rpm			
	K _{EM} [V/1000 rpm]	I ₀ [A]	Plug con. size	Minimum cross-section [mm ²]
EZHD0411U	96	2.89	con.23	1.0 / 1.5
EZHD0412U	94	4.94	con.23	1.0 / 1.5
EZHD0414U	116	6.88	con.23	1.0 / 1.5
EZHD0511U	97	4.06	con.23	1.0 / 1.5
EZHD0512U	121	6.13	con.23	1.0 / 1.5
EZHD0513U	119	8.76	con.23	1.0 / 1.5
EZHD0515U	141	11	con.23	1.0 / 1.5
EZHD0711U	95	7.98	con.23	1.0 / 1.5
EZHD0712U	133	9.99	con.23	1.0 / 1.5
EZHD0713U	122	15.1	con.23	2.5
EZHD0715U	140	21.1	con.40	2.5 / 4.0

Tab. 60: Plug connector size and minimum cross-section, EZHD synchronous servo motors with convection cooling

Minimum cross-section specification for motors with integrated holding brake: The smaller cross-section applies to cable lengths up to max. 12.5 m.

EZHP motors – IC 410 convection cooling

	n_N 3000 rpm			
	K_{EM} [V/1000 rpm]	I_0 [A]	Plug con. size	Minimum cross-section [mm ²]
EZHP_511U	97	4.06	con.23	1.0 / 1.5
EZHP_512U	121	6.13	con.23	1.0 / 1.5
EZHP_513U	119	8.76	con.23	1.0 / 1.5
EZHP_515U	141	11	con.23	1.0 / 1.5
EZHP_711U	95	7.98	con.23	1.0 / 1.5
EZHP_712U	133	9.99	con.23	1.0 / 1.5
EZHP_713U	122	15.1	con.23	2.5
EZHP_715U	140	21.1	con.40	2.5 / 4.0

Tab. 61: Plug connector size and minimum cross-section, EZHP synchronous servo motors with convection cooling

Minimum cross-section specification for motors with integrated holding brake: The smaller cross-section applies to cable lengths up to max. 12.5 m.

Assignment of EZM motors – IC 410 convection cooling

	n _N 3000 rpm			
	K _{EM} [V/1000 rpm]	I ₀ [A]	Plug con. size	Minimum cross-section [mm ²]
EZM511U	97	4	con.23	1.0 / 1.5
EZM512U	121	5.75	con.23	1.0 / 1.5
EZM513U	119	7.6	con.23	1.0 / 1.5
EZM711U	95	7.4	con.23	1.0 / 1.5
EZM712U	133	8.9	con.23	1.0 / 1.5
EZM713U	122	13	con.23	1.5

Tab. 62: Plug connector size and minimum cross-section, EZM synchronous servo motors with convection cooling

Minimum cross-section specification for motors with integrated holding brake: The smaller cross-section applies to cable lengths up to max. 12.5 m.

Assignment of EZS motors – IC 410 convection cooling

	n_N 3000 rpm			
	K_{EM} [V/1000 rpm]	I_0 [A]	Plug con. size	Minimum cross-section [mm ²]
EZS501U	97	3.95	con.23	1.0 / 1.5
EZS502U	121	5.7	con.23	1.0 / 1.5
EZS503U	119	7.6	con.23	1.0 / 1.5
EZS701U	95	7.7	con.23	1.0 / 1.5
EZS702U	133	9.25	con.23	1.0 / 1.5
EZS703U	122	13.5	con.23	1.5

Tab. 63: Plug connector size and minimum cross-section, EZS synchronous servo motors with convection cooling

Minimum cross-section specification for motors with integrated holding brake: The smaller cross-section applies to cable lengths up to max. 12.5 m.

Assignment of EZS motors – IC 416 forced ventilation

	n_N 3000 rpm			
	K_{EM} [V/1000 rpm]	I_0 [A]	Plug con. size	Minimum cross-section [mm ²]
EZS501B	97	5	con.23	1.0 / 1.5
EZS502B	121	8.16	con.23	1.0 / 1.5
EZS503B	119	11.8	con.23	1.0 / 1.5
EZS701B	95	10	con.23	1.0 / 1.5
EZS702B	133	12.9	con.23	1.0 / 1.5
EZS703B	122	20	con.23	2.5

Tab. 64: Plug connector size and minimum cross-section, EZS synchronous servo motors with forced ventilation

Minimum cross-section specification for motors with integrated holding brake: The smaller cross-section applies to cable lengths up to max. 12.5 m.

7.4.1.2 Sizes for ED, EK synchronous servo motors

Determine the size of the plug connector and the minimum cross-section of the cable based on the motor.

ED motors – IC 410 convection cooling

	n _N 2000 rpm				n _N 3000 rpm				n _N = 4000/4200 rpm				n _N 6000 rpm			
	K _{EM} [V/1000 rpm]	I ₀ [A]	Plug con. size	Minimum cross-section [mm ²]	K _{EM} [V/1000 rpm]	I ₀ [A]	Plug con. size	Minimum cross-section [mm ²]	K _{EM} [V/1000 rpm]	I ₀ [A]	Plug con. size	Minimum cross-section [mm ²]	K _{EM} [V/1000 rpm]	I ₀ [A]	Plug con. size	Minimum cross-section [mm ²]
ED212U	—	—	—	—	40	1.12	con.23	1.0	—	—	—	—	40	1.12	con.23	1.0
ED213U	—	—	—	—	40	1.65	con.23	1.0	—	—	—	—	40	1.65	con.23	1.0
ED302U	—	—	—	—	60	1.63	con.23	1.0	—	—	—	—	60	1.63	con.23	1.0
ED303U	—	—	—	—	110	1.14	con.23	1.0	—	—	—	—	60	2.12	con.23	1.0
ED401U	—	—	—	—	140	1.61	con.23	1.5	—	—	—	—	70	3.02	con.23	1.5
ED402U	—	—	—	—	140	3.1	con.23	1.5	—	—	—	—	70	6.1	con.23	1.5
ED403U	—	—	—	—	140	4.43	con.23	1.5	—	—	—	—	70	8.22	con.23	1.5
ED503U	—	—	—	—	140	5.95	con.23	1.5	—	—	—	—	70	11.9	con.23	1.5
ED505U	—	—	—	—	140	9.83	con.23	1.5	100	12.2	con.23	1.5	—	—	—	—
ED704U	210	8.32	con.23	1.5	140	12.5	con.23	1.5	100	16.1	con.23	2.5	—	—	—	—
ED706U	210	11.8	con.23	1.5	140	17.8	con.23	2.5	100	22.5	con.40	4.0	—	—	—	—
ED806U	—	—	—	—	140	30.2	con.40	6.0	100	42.2	con.40	10.0	—	—	—	—
ED808U	210	24.9	con.40	4.0	—	—	—	—	110	48.5	con.40	10.0	—	—	—	—

Tab. 65: Plug connector size and minimum cross-section, ED synchronous servo motors with convection cooling

ED motors – IC 416 forced ventilation

	n _N 2000 rpm				n _N 3000 rpm				n _N = 4000/4200 rpm				n _N 6000 rpm			
	K _{EM} [V/1000 rpm]	I ₀ [A]	Plug con. size	Minimum cross-section [mm ²]	K _{EM} [V/1000 rpm]	I ₀ [A]	Plug con. size	Minimum cross-section [mm ²]	K _{EM} [V/1000 rpm]	I ₀ [A]	Plug con. size	Minimum cross-section [mm ²]	K _{EM} [V/1000 rpm]	I ₀ [A]	Plug con. size	Minimum cross-section [mm ²]
ED212B	—	—	—	—	—	—	—	—	—	—	—	—	—	—	—	—
ED213B	—	—	—	—	—	—	—	—	—	—	—	—	—	—	—	—
ED302B	—	—	—	—	—	—	—	—	—	—	—	—	—	—	—	—
ED303B	—	—	—	—	—	—	—	—	—	—	—	—	—	—	—	—
ED401B	—	—	—	—	140	2.05	con.23	1.5	—	—	—	—	70	3.84	con.23	1.5
ED402B	—	—	—	—	140	4.06	con.23	1.5	—	—	—	—	70	7.99	con.23	1.5
ED403B	—	—	—	—	140	5.89	con.23	1.5	—	—	—	—	70	10.9	con.23	1.5
ED503B	—	—	—	—	140	7.8	con.23	1.5	—	—	—	—	70	15.6	con.23	2.5
ED505B	—	—	—	—	140	14.1	con.23	1.5	100	17.5	con.23	2.5	—	—	—	—
ED704B	210	11	con.23	1.0	140	15.8	con.23	2.5	100	21.7	con.23	4.0	—	—	—	—
ED706B	210	16.7	con.23	2.5	140	24.5	con.23	4.0	100	31.6	con.40	6.0	—	—	—	—
ED806B	—	—	—	—	140	42.6	con.40	10.0	100	59.4	con.58	16.0	—	—	—	—
ED808B	210	16.7	con.40	10.0	—	—	—	—	110	71	con.58	16.0	—	—	—	—

Tab. 66: Plug connector size and minimum cross-section, ED synchronous servo motors with forced ventilation

EK motors – IC 410 convection cooling

	n _N 2000 rpm				n _N 3000 rpm				n _N = 4000/4200 rpm				n _N 6000 rpm			
	K _{EM} [V/1000 rpm]	I ₀ [A]	Plug con. size	Minimum cross-section [mm ²]	K _{EM} [V/1000 rpm]	I ₀ [A]	Plug con. size	Minimum cross-section [mm ²]	K _{EM} [V/1000 rpm]	I ₀ [A]	Plug con. size	Minimum cross-section [mm ²]	K _{EM} [V/1000 rpm]	I ₀ [A]	Plug con. size	Minimum cross-section [mm ²]
EK501U	—	—	—	—	140	2.12	con.23	1.5	—	—	—	—	70	4.24	con.23	1.5
EK502U	—	—	—	—	140	4.06	con.23	1.5	—	—	—	—	70	7.7	con.23	1.5
EK702U	210	4.48	con.23	1.5	140	6.72	con.23	1.5	—	—	—	—	—	—	—	—
EK703U	210	6.02	con.23	1.5	140	9.04	con.23	1.5	—	—	—	—	—	—	—	—
EK803U	—	—	—	—	140	16.5	con.23	2.5	—	—	—	—	—	—	—	—

Tab. 67: Plug connector size and minimum cross-section, EK synchronous servo motors with convection cooling

EK motors – IC 416 forced ventilation

	n _N 2000 rpm				n _N 3000 rpm				n _N = 4000/4200 rpm				n _N 6000 rpm			
	K _{EM} [V/1000 rpm]	I ₀ [A]	Plug con. size	Minimum cross-section [mm ²]	K _{EM} [V/1000 rpm]	I ₀ [A]	Plug con. size	Minimum cross-section [mm ²]	K _{EM} [V/1000 rpm]	I ₀ [A]	Plug con. size	Minimum cross-section [mm ²]	K _{EM} [V/1000 rpm]	I ₀ [A]	Plug con. size	Minimum cross-section [mm ²]
EK501B	—	—	—	—	140	2.73	con.23	1.5	—	—	—	—	70	5.47	con.23	1.5
EK502B	—	—	—	—	140	5.87	con.23	1.5	—	—	—	—	70	10.8	con.23	1.5
EK702B	210	5.82	con.23	1.5	140	8.74	con.23	1.5	—	—	—	—	—	—	—	—
EK703B	210	7.85	con.23	1.5	140	11.8	con.23	1.5	—	—	—	—	—	—	—	—
EK803B	—	—	—	—	140	22.5	con.23	4.0	—	—	—	—	—	—	—	—

Tab. 68: Plug connector size and minimum cross-section, EK synchronous servo motors with forced ventilation

7.4.1.3 Sizes for LM Lean motors

Determine the size of the plug connector and the minimum cross-section of the cable based on the motor.

Assignment of LM Lean motors (nN = 3000 rpm)

	K_{EM} [V/1000 rpm]	I_0 [A]	Plug connector size	Minimum cross-section [mm ²]
LM401	110	1.82	con.23	1.5
LM402	120	2.94	con.23	1.5
LM403	120	4.08	con.23	1.5
LM503	135	5.95	con.23	1.5
LM505	135	8.83	con.23	1.5
LM704	145	11.6	con.23	2.5
LM706	140	16.8	con.23	2.5

Tab. 69: Plug connector size and minimum cross-section, Lean motors

7.4.1.4 Checking the minimum cross-section and contact length

STOBER offers cables with a minimum cross-section for the motors as standard. Depending on the application, however, larger conductor cross-sections may be required. For this reason, take into account the following points in addition for dimensioning the cable:

Stall current I_0 of the motor

For designing the cable, note the stall current I_0 of the motor.

Permitted current carrying capacity of the conductors

Observe the permitted carrying capacity of the cable depending on the ambient and usage conditions. The following standards describe this topic:

- General requirements for machine cabling: EN 60204-1
- Detailed information: DIN VDE 0298-4

Cable length

Observe the length of the power and brake cores:

- The length of the power cores affects the possible short-circuit currents that have to be handled by the device protection
- The length of the brake cores can cause problems due to a voltage drop

Terminal specifications of the drive controller or output choke

The selected cable must be covered by the specification of the terminals of the drive controller or output choke (see [Terminal specifications \[► 118\]](#)).

Plug connector size of the motor

Depending on the plug connector size of the motor, different power core cross-sections are available.

Information

Select a larger conductor cross-section if required by your application.

Contact length of the cable

If the end sleeve does not have the length required in accordance with the terminal specification, select a cable with a longer contact length. If the end sleeve is longer than the length required in accordance with to the terminal specification, shorten the end sleeve to the appropriate length.

7.4.1.5 Codes for EZ, EZHD, EZHP, EZS, EZM synchronous servo motors

The conductor cross-section of the cable and the drive controller series provide you with the cable code, which you in turn can use to determine the identification numbers of ready-made cables.

Information

For drive controllers of sizes 0 to 2, you also need an output choke for an overall length of 50 m or more in order to reduce interference pulses and protect the drive system. For drive controllers of sizes 0 to 2 with output chokes as well as drive controllers of size 3, the maximum overall length of the cable and extension is 100 m.

Cables for con.15

Cables	MDS 5000, SDS 5000, SD6	SB6, SC6, SI6
4 × 1.0 mm ² , 8-core	Up to 25 m: LS8	Up to 25 m: LSI6H
	From 30 m: LS8	From 30 m: LSI6H

Tab. 70: Power cable codes for EZ, EZHD, EZHP, EZS and EZM synchronous servo motors, con.15

Extension cables for con.15

Extension cables	All series
4 × 1.0 mm ² , 8-core	Up to 25 m: LSY
	From 30 m: LSY

Tab. 71: Extension cable codes for EZ, EZHD, EZM and EZS synchronous servo motors, con.15

Cables for con.23

Cables	MDS 5000, SDS 5000, SD6		SB6, SC6, SI6
	Size 0 to 2	Size 3	
4 × 1.0 mm ² , 8-core	Up to 25 m: LSE	—	Up to 25 m: LSI6A
	From 30 m: LSE		From 30 m: LSI6A
4 × 1.5 mm ² , 8-core	Up to 25 m: LSF	—	Up to 25 m: LSI6B
	From 30 m: LSF		From 30 m: LSI6B
4 × 2.5 mm ² , 8-core	Up to 25 m: LSG	Up to 25 m: LSG3	Up to 25 m: LSI6C
	From 30 m: LSG	From 30 m: LSG3	From 30 m: LSI6C
4 × 4.0 mm ² , 8-core	Up to 25 m: LSN1	Up to 25 m: LSN	Up to 25 m: LSI6D
	From 30 m: LSN1	From 30 m: LSN	From 30 m: LSI6D

Tab. 72: Power cable codes for EZ, EZHD, EZHP, EZS and EZM synchronous servo motors, con.23

Extension cables for con.23

Extension cables	All series
4 × 1.0 mm ² , 8-core	Up to 25 m: LS9
	From 30 m: LS9
4 × 1.5 mm ² , 8-core	Up to 25 m: LSP
	From 30 m: LSP
4 × 2.5 mm ² , 8-core	Up to 25 m: LSR
	From 30 m: LSR
4 × 4.0 mm ² , 8-core	Up to 25 m: LSX
	From 30 m: LSX

Tab. 73: Extension cable codes for EZ, EZHD, EZHP, EZS and EZM synchronous servo motors, con.23

Cables for con.40

Cables	MDS 5000, SDS 5000, SD6		SB6, SC6, SI6
	Size 0 to 2	Size 3	
4 × 2.5 mm ² , 8-core	Up to 25 m: LSS	—	Up to 25 m: LSI6I
	From 30 m: LSS		From 30 m: LSI6I
4 × 4.0 mm ² , 8-core	—	Up to 25 m: LSK	Up to 25 m: LSI6E
		From 30 m: LSK	From 30 m: LSI6E
4 × 6.0 mm ² , 8-core	—	Up to 25 m: LSL	Up to 25 m: LSIGF
		From 30 m: LSL	From 30 m: LSIGF
4 × 10.0 mm ² , 8-core	—	Up to 25 m: LSM	Up to 25 m: LSI6G
		From 30 m: LSM	From 30 m: LSI6G
4 × 16.0 mm ² , 8-core	—	Up to 25 m: LSMY	
		From 30 m: LSMY	

Tab. 74: Power cable codes for EZ, EZHD, EZHP, EZS and EZM synchronous servo motors, con.40

Extension cables for con.40

Extension cables	All series
4 × 2.5 mm ² , 8-core	Up to 25 m: LSSE
	From 30 m: LSSE
4 × 4.0 mm ² , 8-core	LSW
4 × 6.0 mm ² , 8-core	LSB
4 × 10.0 mm ² , 8-core	Up to 25 m: LSME
	From 30 m: LSME

Tab. 75: Extension cable codes for EZ, EZHD, EZHP, EZS and EZM synchronous servo motors, con.40

7.4.1.6 Codes for ED, EK synchronous servo motors

The conductor cross-section of the cable and the drive controller series provide you with the cable code, which you in turn can use to determine the identification numbers of ready-made cables.

Information
For drive controllers of sizes 0 to 2, you also need an output choke for an overall length of 50 m or more in order to reduce interference pulses and protect the drive system. For drive controllers of sizes 0 to 2 with output chokes as well as drive controllers of size 3, the maximum overall length of the cable and extension is 100 m.

Cables for con.23

Cables	MDS 5000, SDS 5000, SD6		SB6, SC6, SI6
	Size 0 to 2	Size 3	
4 × 1.0 mm ² , 8-core	Up to 25 m: LSE	—	Up to 25 m: LSI6A
	From 30 m: LSE		From 30 m: LSI6A
4 × 1.5 mm ² , 8-core	Up to 25 m: LSF	—	Up to 25 m: LSI6B
	From 30 m: LSF		From 30 m: LSI6B
4 × 2.5 mm ² , 8-core	Up to 25 m: LSG	Up to 25 m: LSG3	Up to 25 m: LSI6C
	From 30 m: LSG	From 30 m: LSG3	From 30 m: LSI6C
4 × 4.0 mm ² , 8-core	Up to 25 m: LSN1	Up to 25 m: LSN	Up to 25 m: LSI6D
	From 30 m: LSN1	From 30 m: LSN	From 30 m: LSI6D

Tab. 76: Power cable codes for ED, EK synchronous servo motors, con.23

Extension cables for con.23

Cable extension	All series
4 × 1.0 mm ² , 8-core	Up to 25 m: LS9
	From 30 m: LS9
4 × 1.5 mm ² , 8-core	Up to 25 m: LSP
	From 30 m: LSP
4 × 2.5 mm ² , 8-core	Up to 25 m: LSR
	From 30 m: LSR
4 × 4.0 mm ² , 8-core	Up to 25 m: LSX
	From 30 m: LSX

Tab. 77: Extension cable codes for ED, EK synchronous servo motors, con.23

Cables for con.40

Cables	MDS 5000, SDS 5000, SD6		SB6, SC6, SI6
	Size 0 to 2	Size 3	
4 × 2.5 mm ² , 8-core	Up to 25 m: LSS	—	Up to 25 m: LSI6I
	From 30 m: LSS		From 30 m: LSI6I
4 × 4.0 mm ² , 8-core	—	Up to 25 m: LSK	Up to 25 m: LSI6E
		From 30 m: LSK	From 30 m: LSI6E
4 × 6.0 mm ² , 8-core	—	Up to 25 m: LSL	Up to 25 m: LSIGF
		From 30 m: LSL	From 30 m: LSIGF
4 × 10.0 mm ² , 8-core	—	Up to 25 m: LSM	Up to 25 m: LSI6G
		From 30 m: LSM	From 30 m: LSI6G

Tab. 78: Power cable codes for ED, EK synchronous servo motors, con.40

Extension cables for con.40

Cables	All series
4 × 2.5 mm ² , 8-core	Up to 25 m: LSSE
	From 30 m: LSSE
4 × 4.0 mm ² , 8-core	LSW
4 × 6.0 mm ² , 8-core	LSB
4 × 10.0 mm ² , 8-core	Up to 25 m: LSME
	From 30 m: LSME

Tab. 79: Extension cable codes for ED, EK synchronous servo motors, con.40

Cables for con.58

Cables	MDS 5000, SDS 5000, SD6
	Size 3
4 × 16.0 mm ² , 8-core	Up to 25 m: LKY
	From 30 m: LKY
4 × 25.0 mm ² , 8-core	Up to 25 m: Truck
	From 30 m: Truck

Tab. 80: Power cable codes for ED, EK synchronous servo motors, con.58

7.4.1.7 Codes for LM Lean motors

The conductor cross-section of the cable and the drive controller series provide you with the cable code, which you in turn can use to determine the identification numbers of ready-made cables.

Information

If Lean motors are connected, output chokes must not be used. For Lean motors, the maximum overall length of the cable and extension is 50 m. The use of cables with a length greater than 50 m and up to maximum 100 m must be checked by STOBER for the application.

Cables for con.23

Cables	SB6, SC6, SI6
4 × 1.5 mm ² , 8-core	Up to 25 m: LSI6B
	From 30 m: LSI6B
4 × 2.5 mm ² , 8-core	Up to 25 m: LSI6C
	From 30 m: LSI6C

Tab. 81: Power cable codes for LM Lean motors, con.23

Extension cables for con.23

Cable extension	SB6, SC6, SI6
4 × 1.5 mm ² , 8-core	Up to 25 m: LSP
	From 30 m: LSP
4 × 2.5 mm ² , 8-core	Up to 25 m: LSR
	From 30 m: LSR

Tab. 82: Extension cable codes for LM Lean motors, con.23

7.4.2 Ready-made power cables

The cable code provides you with the identification numbers for ready-made cables up to 100 m in length.

Connection of synchronous servo motors and asynchronous motors

Information

For drive controllers of sizes 0 to 2, you also need an output choke for an overall length of 50 m or more in order to reduce interference pulses and protect the drive system. For drive controllers of sizes 0 to 2 with output chokes as well as drive controllers of size 3, the maximum overall length of the cable and extension is 100 m.

Connection of Lean motors

Information

If Lean motors are connected, output chokes must not be used. For Lean motors, the maximum overall length of the cable and extension is 50 m. The use of cables with a length greater than 50 m and up to maximum 100 m must be checked by STOBER for the application.

Power cables up to 25 m

Code	Size	Cable length [m]								
		2.5	5	7.5	10	12.5	15	18	20	25
LS8	con.15	56755	56756	56757	56758	56759	56760	56761	56762	56763
LSI6H	con.15	59174	59175	59176	59177	59178	59179	59180	59181	59182
LSE	con.23	54312	54313	54314	54315	54316	54317	54318	54319	54320
LSF	con.23	54338	54339	54340	54341	54342	54343	54344	54345	54346
LSG	con.23	54363	54364	54365	54366	54367	54368	54369	54370	54371
LSN1	con.23	57718	57719	57720	57721	57722	57723	57724	57725	57726
LSG3	con.23	5050318	5050319	5050320	5050321	5050322	5050323	5050324	5050325	5050326
LSN	con.23	54383	54384	54385	54386	54387	54388	54389	54390	54391
LSI6A	con.23	58500	58501	58502	58503	58504	58505	58506	58507	58508
LSI6B	con.23	58518	58519	58520	58521	58522	58523	58524	58525	58526
LSI6C	con.23	58536	58537	58538	58539	58540	58541	58542	58543	58544
LSI6D	con.23	58554	58555	58556	58557	58558	58559	58560	58561	58562
LSS	con.40	54671	54672	54673	54674	54675	54676	54677	54678	54679
LSK	con.40	54473	54474	54475	54476	54477	54478	54479	54480	54481
LSL	con.40	54491	54492	54493	54494	54495	54496	54497	54498	54499
LSM	con.40	54509	54510	54511	54512	54513	54514	54515	54516	54517
LSI6I	con.40	59210	59211	59212	59213	59214	59215	59216	59217	59218
LSI6E	con.40	58572	58573	58574	58575	58576	58577	58578	58579	58580
LSI6F	con.40	58590	58591	58592	58593	58594	58595	58596	58597	58598
LSI6G	con.40	58608	58609	58610	58611	58612	58613	58614	58615	58616
LSMY	con.40	5052752	5052753	5052754	5052755	5052756	5052757	5052758	5052759	5052760
LKY	con.58	53910	53911	53912	53913	53914	53915	53916	53917	53918
LKW	con.58	53928	53929	53930	53931	53932	53933	53934	53935	53936

Tab. 83: Ready-made power cables up to 25 m

Power cables from 30 m

Code	Size	Cable length [m]								
		30	35	40	50	60	70	80	90	100
LS8	con.15	56764	56765	56766	56767	56768	56769	56770	56771	56772
LSI6H	con.15	59183	59184	59185	59186	59187	59188	59189	59190	59191
LSE	con.23	54321	54322	54323	54324	54325	54326	54327	54328	54329
LSF	con.23	54347	54348	54349	54350	54351	54352	54353	54354	54355
LSG	con.23	54372	54373	54374	54375	54376	54377	54378	54379	54380
LSN1	con.23	57727	57728	57729	57730	57731	57732	57733	57734	57735
LSG3	con.23	5050327	5050328	5050329	5050330	5050331	5050332	5050333	5050334	5050335
LSN	con.23	54392	54393	54394	54395	54396	54397	54398	54399	54400
LSI6A	con.23	58509	58510	58511	58512	58513	58514	58515	58516	58517
LSI6B	con.23	58527	58528	58529	58530	58531	58532	58533	58534	58535
LSI6C	con.23	58545	58546	58547	58548	58549	58550	58551	58552	58553
LSI6D	con.23	58563	58564	58565	58566	58567	58568	58569	58570	58571
LSS	con.40	54680	54681	54682	54683	54684	54685	54686	54687	54688
LSK	con.40	54482	54483	54484	54485	54486	54487	54488	54489	54490
LSL	con.40	54500	54501	54502	54503	54504	54505	54506	54507	54508
LSM	con.40	54518	54519	54520	54521	54522	54523	54524	54525	54526
LSI6I	con.40	59219	59220	59221	59222	59223	59224	59225	59226	59227
LSI6E	con.40	58581	58582	58583	58584	58585	58586	58587	58588	58589
LSI6F	con.40	58599	58600	58601	58602	58603	58604	58605	58606	58607
LSI6G	con.40	58617	58618	58619	58620	58621	58622	58623	58624	58625
LSMY	con.40	5052761	5052762	5052763	5052764	5052765	5052766	5052767	5052768	5052769
LKY	con.58	53919	53920	53921	53922	53923	53924	53925	53926	53927
LKW	con.58	53937	53938	53939	53940	53941	53942	53943	53944	53945

Tab. 84: Ready-made power cables from 30 m

Extension cables up to 25 m

Code	Size	Cable length [m]								
		2.5	5	7.5	10	12.5	15	18	20	25
LSY	con.15	57578	57579	57580	57581	57582	57583	57584	57585	57586
LS9	con.23	54599	54600	54601	54602	54603	54604	54605	54606	54607
LSP	con.23	54563	54564	54565	54566	54567	54568	54569	54570	54571
LSR	con.23	54581	54582	54583	54584	54585	54586	54587	54588	54589
LSX	con.23	54545	54546	54547	54548	54549	54550	54551	54552	54553
LSSE	con.40	57694	57695	57696	57697	57698	57699	57700	57701	57702
LSW	con.40	56776	56777	56778	55038	—	—	—	—	—
LSB	con.40	56998	56999	—	59884	—	59311	—	—	—
LSME	con.40	58273	58274	58275	58276	58277	58278	58279	58280	58281

Tab. 85: Ready-made extension cables for power cables up to 25 m

Extension cables from 30 m

Code	Size	Cable length [m]								
		30	35	40	50	60	70	80	90	100
LSY	con.15	57587	57588	57589	57590	57591	57592	57593	57594	57595
LS9	con.23	54608	54609	54610	54611	54612	54613	54614	54615	54616
LSP	con.23	54572	54573	54574	54575	54576	54577	54578	54579	54580
LSR	con.23	54590	54591	54592	54593	54594	54595	54596	54597	54598
LSX	con.23	54554	54555	54556	54557	54558	54559	54560	54561	54562
LSSE	con.40	57703	57704	57705	57706	57707	57708	57709	57710	57711
LSME	con.40	58282	58283	58284	58285	58286	58287	58288	58289	58290

Tab. 86: Ready-made extension cables for power cables from 30 m

7.5 Service packs for power cables

If you would like to finish your cable yourself, you can find information in this chapter about available service packs. Our service packs contain the motor-side connector and the required contacts. To finish the contacts correctly, you require a suitable crimping tool for the respective contact type. More detailed information can be found in the enclosed assembly instructions.

Information

Be aware that the use of unsuitable cables or poorly made connections can cause subsequent damage. For this reason, we reserve the right to reject claims under the warranty in this case.

Type	con.15	con.23	con.40	con.58
4 × 1.0 mm ² , 9-pin	57161	—	—	—
4 × 1.5 mm ² to 4 × 2.5 mm ² , 8-pin	—	55016	—	—
4 × 2.5 mm ² to 4 × 4.0 mm ² , 8-pin	—	55020	—	—
4 × 2.5 mm ² to 4 × 4.0 mm ² , 8-pin	—	—	58729	—
4 × 6.0 mm ² to 4 × 10.0 mm ² , 8-pin	—	—	55021	—
4 × 16.0 mm ² , 8-pin	—	—	—	57030

Tab. 87: Identification numbers of service packs for power cables

7.6 Accessories

You can find information about the available accessories in the following chapters.

7.6.1 TEP output choke

Output chokes are required for connecting size 0 to 2 drive controllers to synchronous servo motors or asynchronous motors from a cable length > 50 m in order to reduce interference pulses and protect the drive system. If Lean motors are connected, output chokes must not be used.

Information

The following technical data only applies to a rotating magnetic field frequency of 200 Hz. For example, this rotating magnetic field frequency is achieved with a motor with 4 pole pairs and a nominal speed of 3000 rpm. Always observe the specified derating for higher rotating magnetic field frequencies. Also observe the relationship with the clock frequency.

Properties

Technical data	TEP3720-OES41	TEP3820-OCS41	TEP4020-ORS41
ID No.	53188	53189	53190
Voltage range	3 × 0 to 480 V _{AC}		
Frequency range	0 – 200 Hz		
Nominal current I _{N,MF} at 4 kHz	4 A	17.5 A	38 A
Nominal current I _{N,MF} at 8 kHz	3.3 A	15.2 A	30.4 A
Max. permitted motor cable length with output choke	100 m		
Max. surrounding temperature $\vartheta_{amb,max}$	40 °C		
Protection class	IP00		
Winding losses	11 W	29 W	61 W
Iron losses	25 W	16 W	33 W
Connection	Screw terminal		
Max. conductor cross-section	10 mm ²		
UL Recognized Component (CAN; USA)	Yes		
Marks and test symbols	cURus, CE		

Tab. 88: TEP technical data

Dimensions

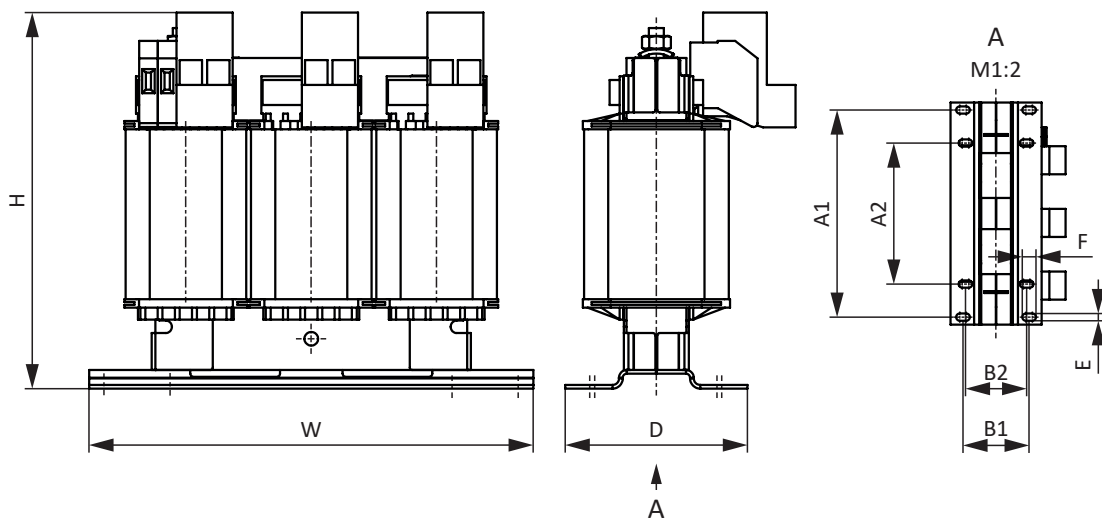

Fig. 5: TEP dimensional drawing

Dimension	TEP3720-OES41	TEP3820-OCS41	TEP4020-ORS41
Height H [mm]	Max. 150	Max. 152	Max. 172
Width W [mm]	178	178	219
Depth D [mm]	73	88	119
Vertical distance – A1 fastening bores [mm]	166	166	201
Vertical distance – A2 fastening bores [mm]	113	113	136
Horizontal distance – B1 fastening bores [mm]	53	68	89
Horizontal distance – B2 fastening bores [mm]	49	64	76
Drill holes – Depth E [mm]	5.8	5.8	7
Drill holes – Width F [mm]	11	11	13
Screw connection – M	M5	M5	M6
Weight without packaging [g]	2900	5900	8800

Tab. 89: TEP dimensions and weight

More information on chokes can be found in the manuals of the drive controllers (see [Detailed information](#) [▶ 123]).

8 One Cable Solution

The synchronous servo motors are equipped with plug connectors as standard.

A motor connection as a One Cable Solution (OCS) combined with an EnDat 3 or HIPERFACE DSL encoder requires hybrid cables which feature encoder communication and power transmission in a shared cable.

STOBER provides suitable cables in various lengths, conductor cross-sections and connector sizes.

For applications with a cable length of up to 12.5 m, conductor cross-sections of 1.0 or 1.5 mm² and a non-moving installation, STOBER recommends the OCS-Basic hybrid cables. For longer lengths or installation in moving cable runs (such as a drag chain), use the OCS-Advanced hybrid cables.

Information

For connecting as a One Cable Solution, use exclusively hybrid cables from STOBER. The use of unsuitable cables or poorly made connections can cause subsequent damage. For this reason, we reserve the right to reject claims under the warranty in this case.

8.1 Connection description

The hybrid cables are available in plug connector size con.23 with a speedtec quick-lock. Depending on the drive controller, the terminal assignment may differ from the example shown here.

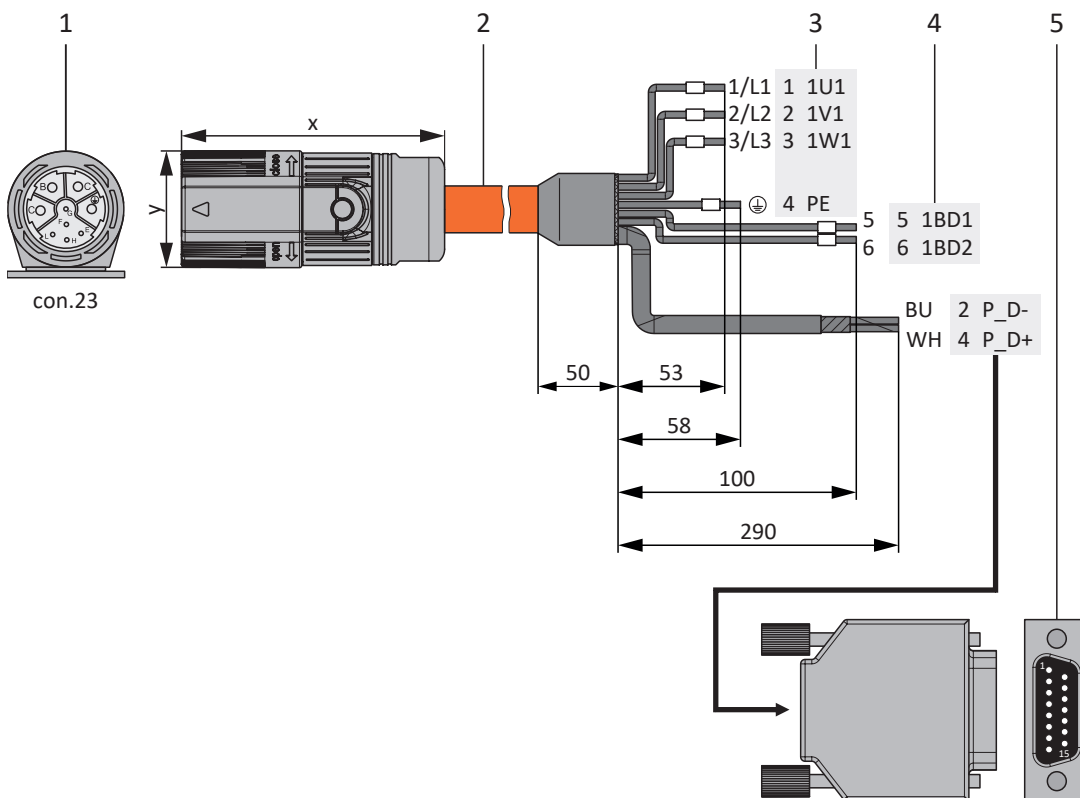

- 1 Plug connectors
- 2 Hybrid cables
- 3 Connection to terminal X20, motor
- 4 Connection of terminal X2, brake
- 5 D-sub X4

Hybrid cables – con.23 plug connectors

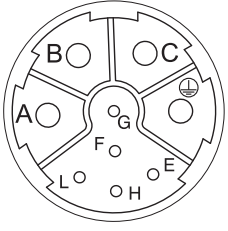
Connection diagram	Motor (1)		Cable (2)	Drive controller (3) – (5)		
	Pin	Designation	Core No./ Core color	Pin X20	Pin X2	Pin X4
	A	1U1	1/L1	1	—	—
	B	1V1	2/L2	2	—	—
	C	1W1	3/L3	3	—	—
	E	P_D-	BU	—	—	2
	F	P_D shield	—	—	—	Housing
	G	1BD1	5	—	5	—
	H	P_D+	WH	—	—	4
	L	1BD2	6	—	6	—
	⊕	PE	GNYE	4	—	—
	Housing	Shield	—	Shield contact	—	—

Tab. 90: con.23 hybrid cable pin assignment

Length x [mm]	Diameter y [mm]
78	26

Tab. 91: con.23 connector dimensions

8.2 Technical data

IP protection class of the plug connectors

The plug connectors meet the IP 66/67 protection class (in accordance with IEC 60529). This information applies if both parts of the plug connector are connected together properly. Plug connectors have to be protected against environmental factors that affect functionality (dust, moisture, etc.) in accordance with the type approval laws.

Conductor design

OCS-Basic

Flexible, bare copper; all elements mounted in a round design at optimum length with filler

OCS-Advanced

Finely stranded wire made of bare copper wires in accordance with EN 60228 (VDE 0295), class 6; 4 cores and 2 pairs twisted with optional filling elements

Voltage

- Nominal voltage (DIN VDE): power cores $U_o/U = 0.6/1.0$ kV
- Nominal voltage (DIN VDE): pilot cores $U_o/U = 0.6/1.0$ V
- Voltage (UL/CSA): power cores 1000 V
- Voltage (UL/CSA): pilot cores 1000 V

Test voltage

OCS-Basic

- Core/core and core/shield: power cores 4000 V × 5 min
- Core/core and core/shield: pilot cores 3000 V × 5 min

OCS-Advanced

- Core/core and core/shield: power cores 4000 V × 5 min
- Core/core and core/shield: pilot cores 4000 V × 5 min

Current carrying capacity

Power cores in accordance with DIN VDE 0298, part 4, tables 11 and 17; pilot cores 0.75 mm² and 1 mm² in accordance with DIN VDE 0298, part 4; pilot cores AWG22 (0.34 mm²) based on DIN VDE 0891, part 1

Power cores			
Conductor cross-section [mm ²]	1.0	1.5	2.5
Nominal current $I_{N,CAB}$ [A]	13.1	15.7	22.6

Pilot cores			
Conductor cross-section [mm ²]	AWG22 (approx. 0.34)	0.75	1.0
Nominal current $I_{N,CAB}$ [A]	4.4	10.4	13.1

Limit temperature

Temperature range by operating mode	
Permanently installed	-40 °C to +80 °C
Free to move	-30 °C to +80 °C

Tensile stress when being laid

- Free to move: 20 N per mm² conductor cross-section
- Permanently installed: 50 N per mm² conductor cross-section

Smallest permissible bending radius

- Free to move: 10 x d_{out}
- Permanently installed: 5 x d_{out}

Torsional stress

± 30°/m

Bending resistance

Cycles

Min. 5 million cycles

Travel velocity

Max. 240 m/min

Acceleration

- Max. 30 m/s² to 5 m travel path
- Max. 15 m/s² to 10 m travel path
- Max. 5 m/s² to 20 m travel path

Resistance

OCS-Basic

- Oil-resistant: in accordance with EN 50363-10-2
- Chemical: UV-resistant in accordance with EN 50289-4-17, hydrolysis-resistant in accordance with EN 50396, microbacteria-resistant

OCS-Advanced

- Oil-resistant in accordance with EN 60811-404
- Chemical: good against acids, bases, solvents, hydraulic fluids

Outer sheath

PUR

Banding

Fleece tape with overlapping

Core insulation

PP

Core identification

Power cores		
	OCS-Basic	OCS-Advanced
Core 1	Black imprinted with U/L1/C/L+	Black imprinted with 1
Core 2	Black imprinted with V/L2	Black imprinted with 2
Core 3	Black imprinted with W/L3/D/L-	Black imprinted with 3
Grounding conductor	Green-yellow	Green-yellow

Pilot cores		
	OCS-Basic	OCS-Advanced
Pair 1	Black and white	Black with numbers 5 + 6
Pair 2	White and blue	White and blue

Sheath identification**OCS-Basic**

Orange color (similar to RAL 2003) with imprint of cable manufacturer

OCS-Advanced

Orange color (similar to RAL 2003) imprinted with STOBER

Shielding

- Core shielding of the pilot cores in pairs with tin-plated copper braid, optical coverage $\geq 85\%$ and metallized plastic non-woven fabric
- Complete shielding of tin-plated Cu braid, optical coverage $\geq 85\%$

Insulation material

Halogen-free in accordance with EN 60754-1, silicone-free, CFC-free, free from paint-wetting impairment substances (PWIS)

Flammability**OCS-Basic**

Combustion behavior: flame retardant and self-extinguishing in accordance with IEC 60332-1-2, UL/CSA FT1, UL VW-1

OCS-Advanced

Combustion behavior: flame retardant and self-extinguishing in accordance with IEC 60332-1-2, UL758 cable flame test

RoHS conformity

Free of hazardous substances in accordance with the RoHS-2 Directive 2011/65/EU and RoHS-3 Directive 2015/863

Conductor cross-sections

Cable diameter	Description	Weight	ID No. (non-terminated cable)	
			New	Previously
OCS-Basic				
Max. 13.6 mm	(4G 1.0 + (2 x 0.75) + (2 x AWG22))	0.23 kg/m	5052117	—
Max. 13.7 mm	(4G 1.5 + (2 x 1.0) + (2 x AWG22))	0.26 kg/m	5052118	—
OCS-Advanced				
Max. 14.7 mm	(4G 1.5 + (2 x 0.75) + (2 x AWG22))	0.32 kg/m	5050030	5050707
Max. 16.8 mm	(4G 2.5 + (2 x 0.75) + (2 x AWG22))	0.40 kg/m	5050031	5050708

"(...)" = Shield

End sleeves

End sleeves in accordance with DIN 46228-4		
Conductor cross-section [mm ²]	0.34 – 1.5	2.5
Contact length [mm]	10	18

Design

UL/CSA (OCS Basic: E356538, OCS Advanced: E170315); for UL file number, see cable imprint

Capacitance, inductance, DC resistance

Operating capacitance in accordance with EN 50395 clause 8.1	
OCS-Basic, conductor cross-section 4 × 1.0 mm²	
Cores 1.0 mm ²	Max. 130 nF/km
Pair 0.75 mm ²	Max. 150 nF/km
Pair AWG22	Max. 80 nF/km
OCS-Basic, conductor cross-section 4 × 1.5 mm²	
Cores 1.5 mm ²	Max. 150 nF/km
Pair 1.0 mm ²	Max. 150 nF/km
Pair AWG22	Max. 80 nF/km
OCS-Advanced, conductor cross-section 4 × 1.5 mm²	
Cores 1.5 mm ²	Max. 130 nF/km
Pair 0.75 mm ²	Max. 140 nF/km
Pair AWG22	Max. 80 nF/km
OCS-Advanced, conductor cross-section 4 × 2.5 mm²	
Cores 2.5 mm ²	Max. 130 nF/km
Pair 0.75 mm ²	Max. 140 nF/km
Pair AWG22	Max. 80 nF/km

Inductance in accordance with EN 50289-1-12	
OCS-Basic, conductor cross-section 4 × 1.0 mm²	
Cores 1.0 mm ²	0.7 mH/km
Pair 0.75 mm ²	0.7 mH/km
Pair AWG22	On request
OCS-Basic, conductor cross-section 4 × 1.5 mm²	
Cores 1.5 mm ²	0.7 mH/km
Pair 1.0 mm ²	0.7 mH/km
Pair AWG22	On request
OCS-Advanced, conductor cross-section 4 × 1.5 mm²	
Cores 1.5 mm ²	0.45 mH/km
Pair 0.75 mm ²	0.3 mH/km
Pair AWG22	0.5 mH/km
OCS-Advanced, conductor cross-section 4 × 2.5 mm²	
Cores 2.5 mm ²	0.45 mH/km
Pair 0.75 mm ²	0.3 mH/km
Pair AWG22	0.5 mH/km

DC resistance at 20 °C	
OCS-Basic, conductor cross-section 4 × 1.0 mm²	
Cores 1.0 mm ²	Max. 19.5 Ω/km
Pair 0.75 mm ²	Max. 26.0 Ω/km
Pair AWG22	Max. 59.4 Ω/km
OCS-Basic, conductor cross-section 4 × 1.5 mm²	
Cores 1.5 mm ²	Max. 13.3 Ω/km
Pair 1.0 mm ²	Max. 19.5 Ω/km
Pair AWG22	Max. 59.4 Ω/km
OCS-Advanced, conductor cross-section 4 × 1.5 mm²	
Cores 1.5 mm ²	Max. 13.3 Ω/km
Pair 0.75 mm ²	Max. 26.0 Ω/km
Pair AWG22	Max. 55.0 Ω/km
OCS-Advanced, conductor cross-section 4 × 2.5 mm²	
Cores 2.5 mm ²	Max. 7.98 Ω/km
Pair 0.75 mm ²	Max. 26.0 Ω/km
Pair AWG22	Max. 55.0 Ω/km

8.3 Determining the cable code for ready-made cables in 3 steps

Information

Note that the cable codes used in this documentation are intended only to refer to the overview and selection tables within this manual. The cable codes are not part of the ordering process and are not printed on the cables.

8.3.1 Sizes for EZ, EZS synchronous servo motors

Determine the size of the plug connector and the minimum cross-section of the cable based on the motor.

EZ motors – IC 410 convection cooling

	n _N 3000 rpm			n _N 4500 rpm			n _N 6000 rpm		
	K _{EM} V/1000 rpm	Plug con. size	Minimum cross-section mm ²	K _{EM} V/1000 rpm	Plug con. size	Minimum cross-section mm ²	K _{EM} V/1000 rpm	Plug con. size	Minimum cross-section mm ²
EZ202U	—	—	—	—	—	—	40	con.23	1.0 / 1.5
EZ203U	—	—	—	—	—	—	40	con.23	1.0 / 1.5
EZ301U	40	con.23	1.0 / 1.5	—	—	—	40	con.23	1.0 / 1.5
EZ302U	86	con.23	1.0 / 1.5	—	—	—	42	con.23	1.0 / 1.5
EZ303U	109	con.23	1.0 / 1.5	—	—	—	55	con.23	1.0 / 1.5
EZ401U	96	con.23	1.0 / 1.5	—	—	—	47	con.23	1.0 / 1.5
EZ402U	94	con.23	1.0 / 1.5	—	—	—	60	con.23	1.0 / 1.5
EZ404U	116	con.23	1.0 / 1.5	—	—	—	78	con.23	1.0 / 1.5
EZ501U	97	con.23	1.0 / 1.5	—	—	—	68	con.23	1.0 / 1.5
EZ502U	121	con.23	1.0 / 1.5	—	—	—	72	con.23	1.0 / 1.5
EZ503U	119	con.23	1.0 / 1.5	—	—	—	84	con.23	1.0 / 1.5
EZ505U	141	con.23	1.0 / 1.5	103	con.23	1.5	—	—	—
EZ701U	95	con.23	1.0 / 1.5	—	—	—	76	con.23	1.0 / 1.5
EZ702U	133	con.23	1.0 / 1.5	—	—	—	82	con.23	2.5
EZ703U	122	con.23	1.5	99	con.23	2.5	—	—	—
EZ705U	140	con.23	2.5	—	—	—	—	—	—

Tab. 92: Plug connector size and minimum cross-section, EZ synchronous servo motors with convection cooling

Minimum cross-section specification for motors with integrated holding brake: The smaller cross-section applies to cable lengths up to max. 12.5 m.

EZ motors – IC 416 forced ventilation

	n _N 3000 rpm			n _N 4500 rpm			n _N 6000 rpm		
	K _{EM} V/1000 rpm	Plug con. size	Minimum cross-section mm ²	K _{EM} V/1000 rpm	Plug con. size	Minimum cross-section mm ²	K _{EM} V/1000 rpm	Plug con. size	Minimum cross-section mm ²
EZ401B	96	con.23	1.0 / 1.5	—	—	—	47	con.23	1.0 / 1.5
EZ402B	94	con.23	1.0 / 1.5	—	—	—	60	con.23	1.0 / 1.5
EZ404B	116	con.23	1.0 / 1.5	—	—	—	78	con.23	1.0 / 1.5
EZ501B	97	con.23	1.0 / 1.5	—	—	—	68	con.23	1.0 / 1.5
EZ502B	121	con.23	1.0 / 1.5	—	—	—	72	con.23	1.5
EZ503B	119	con.23	1.0 / 1.5	—	—	—	84	con.23	2.5
EZ505B	141	con.23	1.5	103	con.23	1.5	—	—	—
EZ701B	95	con.23	1.0 / 1.5	—	—	—	76	con.23	1.0 / 1.5
EZ702B	133	con.23	1.0 / 1.5	—	—	—	—	—	—
EZ703B	122	con.23	2.5	—	—	—	—	—	—

Tab. 93: Plug connector size and minimum cross-section, EZ synchronous servo motors with forced ventilation

Minimum cross-section specification for motors with integrated holding brake: The smaller cross-section applies to cable lengths up to max. 12.5 m.

Assignment of EZS motors – IC 410 convection cooling

	n_N 3000 rpm			
	K_{EM} [V/1000 rpm]	I_0 [A]	Plug con. size	Minimum cross-section [mm ²]
EZS501U	97	3.95	con.23	1.0 / 1.5
EZS502U	121	5.7	con.23	1.0 / 1.5
EZS503U	119	7.6	con.23	1.0 / 1.5
EZS701U	95	7.7	con.23	1.0 / 1.5
EZS702U	133	9.25	con.23	1.0 / 1.5
EZS703U	122	13.5	con.23	1.5

Tab. 94: Plug connector size and minimum cross-section, EZS synchronous servo motors with convection cooling

Minimum cross-section specification for motors with integrated holding brake: The smaller cross-section applies to cable lengths up to max. 12.5 m.

Assignment of EZS motors – IC 416 forced ventilation

	n_N 3000 rpm			
	K_{EM} [V/1000 rpm]	I_0 [A]	Plug con. size	Minimum cross-section [mm ²]
EZS501B	97	5	con.23	1.0 / 1.5
EZS502B	121	8.16	con.23	1.0 / 1.5
EZS503B	119	11.8	con.23	1.0 / 1.5
EZS701B	95	10	con.23	1.0 / 1.5
EZS702B	133	12.9	con.23	1.0 / 1.5
EZS703B	122	20	con.23	2.5

Tab. 95: Plug connector size and minimum cross-section, EZS synchronous servo motors with forced ventilation

Minimum cross-section specification for motors with integrated holding brake: The smaller cross-section applies to cable lengths up to max. 12.5 m.

8.3.2 Checking the minimum cross-section and contact length

STOBER offers cables with a minimum cross-section for the motors as standard. Depending on the application, however, larger conductor cross-sections may be required. For this reason, take into account the following points in addition for dimensioning the cable:

Stall current I_0 of the motor

For designing the cable, note the stall current I_0 of the motor.

Permitted current carrying capacity of the conductors

Observe the permitted carrying capacity of the cable depending on the ambient and usage conditions. The following standards describe this topic:

- General requirements for machine cabling: EN 60204-1
- Detailed information: DIN VDE 0298-4

Cable length

Observe the length of the power and brake cores:

- The length of the power cores affects the possible short-circuit currents that have to be handled by the device protection
- The length of the brake cores can cause problems due to a voltage drop

Terminal specifications of the drive controller or output choke

The selected cable must be covered by the specification of the terminals of the drive controller or output choke (see [Terminal specifications \[► 118\]](#)).

Plug connector size of the motor

Depending on the plug connector size of the motor, different power core cross-sections are available.

Information

Select a larger conductor cross-section if required by your application.

Contact length of the cable

If the end sleeve does not have the length required in accordance with the terminal specification, select a cable with a longer contact length. If the end sleeve is longer than the length required in accordance with to the terminal specification, shorten the end sleeve to the appropriate length.

8.3.3 Codes for EZ, EZS synchronous servo motors

The conductor cross-section of the cable and the drive controller series provide you with the cable code, which you in turn can use to determine the identification numbers of ready-made cables.

Cables for con.23

Cables	SB6, SC6, SI6
OCS-Basic: 4 × 1.0 mm ² , 8-core	Up to 12.5 m: HK2J
OCS-Basic: 4 × 1.5 mm ² , 8-core	Up to 12.5 m: HK2K
OCS-Advanced: 4 × 1.5 mm ² , 8-core	Up to 25 m: HK2G
	From 30 m: HK2G
OCS-Advanced: 4 × 2.5 mm ² , 8-core	Up to 25 m: HK2H
	From 30 m: HK2H

Tab. 96: Hybrid cable codes for EZ and EZS synchronous servo motors, con.23

8.4 Ready-made hybrid cables

The cable code provides you with the identification numbers for ready-made cables up to 100 m in length.

Information

For drive controllers of sizes 0 to 2, you also need an output choke for an overall length of 50 m or more in order to reduce interference pulses and protect the drive system. For drive controllers of sizes 0 to 2 with output chokes as well as drive controllers of size 3, the maximum overall length is 100 m.

OCS-Basic hybrid cable up to 12.5 m

Code	Size	Cable length [m]								
		2.5	5	7.5	10	12.5	15	18	20	25
HK2J	con.23	5052267	5052268	5052269	5052270	5052271	—	—	—	—
HK2K	con.23	5052251	5052252	5052253	5052254	5052255	—	—	—	—

Tab. 97: Ready-made OCS-Basic hybrid cables up to 12.5 m

OCS-Advanced hybrid cable up to 25 m

Code	Size	Cable length [m]								
		2.5	5	7.5	10	12.5	15	18	20	25
HK2G	con.23	5050467	5050468	5050469	5050470	5050471	5050472	5050473	5050474	5050308
HK2H	con.23	5050632	5050633	5050634	5050635	5050636	5050637	5050638	5050639	5050640

Tab. 98: Ready-made OCS-Advanced hybrid cables up to 25 m

OCS-Advanced hybrid cable from 30 m

Code	Size	Cable length [m]								
		30	35	40	50	60	70	80	90	100
HK2G	con.23	5050475	5050310	5050476	5050312	5050313	5050314	5050477	5050316	5050478
HK2H	con.23	5050641	5050642	5050643	5050644	5050645	5050646	5050647	5050648	5050649

Tab. 99: Ready-made OCS-Advanced hybrid cables from 30 m

8.5 Accessories

You can find information about the available accessories in the following chapters.

8.5.1 TEP output choke

Output chokes are required for connecting size 0 to 2 drive controllers to synchronous servo motors or asynchronous motors from a cable length > 50 m in order to reduce interference pulses and protect the drive system. If Lean motors are connected, output chokes must not be used.

Information

The following technical data only applies to a rotating magnetic field frequency of 200 Hz. For example, this rotating magnetic field frequency is achieved with a motor with 4 pole pairs and a nominal speed of 3000 rpm. Always observe the specified derating for higher rotating magnetic field frequencies. Also observe the relationship with the clock frequency.

Properties

Technical data	TEP3720-0ES41	TEP3820-0CS41	TEP4020-0RS41
ID No.	53188	53189	53190
Voltage range	3 × 0 to 480 V _{AC}		
Frequency range	0 – 200 Hz		
Nominal current I _{N,MF} at 4 kHz	4 A	17.5 A	38 A
Nominal current I _{N,MF} at 8 kHz	3.3 A	15.2 A	30.4 A
Max. permitted motor cable length with output choke	100 m		
Max. surrounding temperature $\vartheta_{amb,max}$	40 °C		
Protection class	IP00		
Winding losses	11 W	29 W	61 W
Iron losses	25 W	16 W	33 W
Connection	Screw terminal		
Max. conductor cross-section	10 mm ²		
UL Recognized Component (CAN; USA)	Yes		
Marks and test symbols	cURus, CE		

Tab. 100: TEP technical data

Dimensions

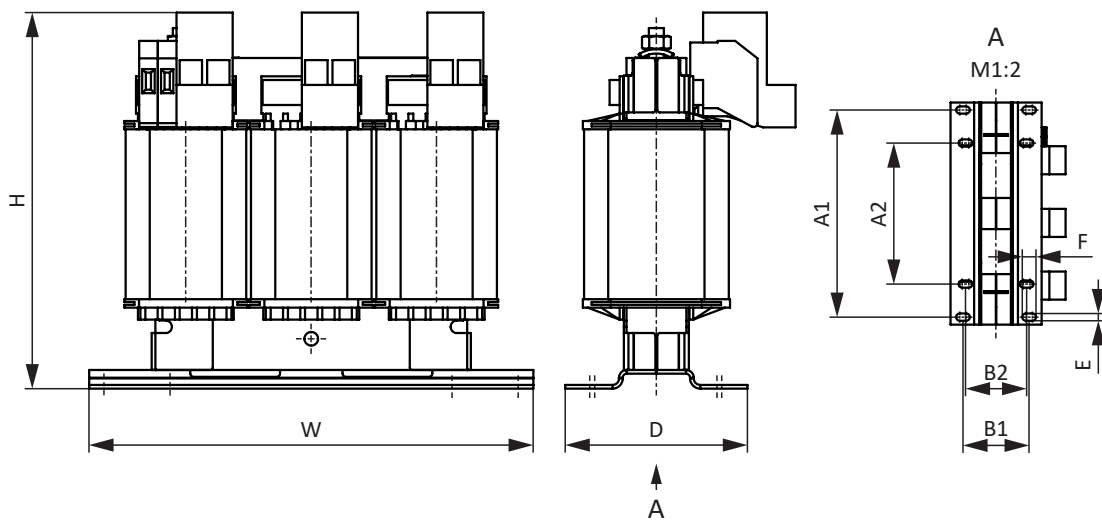

Fig. 6: TEP dimensional drawing

Dimension	TEP3720-OES41	TEP3820-OCS41	TEP4020-ORS41
Height H [mm]	Max. 150	Max. 152	Max. 172
Width W [mm]	178	178	219
Depth D [mm]	73	88	119
Vertical distance – A1 fastening bores [mm]	166	166	201
Vertical distance – A2 fastening bores [mm]	113	113	136
Horizontal distance – B1 fastening bores [mm]	53	68	89
Horizontal distance – B2 fastening bores [mm]	49	64	76
Drill holes – Depth E [mm]	5.8	5.8	7
Drill holes – Width F [mm]	11	11	13
Screw connection – M	M5	M5	M6
Weight without packaging [g]	2900	5900	8800

Tab. 101: TEP dimensions and weight

More information on chokes can be found in the manuals of the drive controllers (see [Detailed information](#) [▶ 123]).

9 Appendix

9.1 Terminal specifications

The cores for the motor temperature sensor and brake in the power cable are manufactured with end sleeves with plastic collars and an insulation stripping length of 10 mm, appropriate for the drive controllers.

The requirements for terminal X20 for the motor connection depend on the series and size of the drive controller. You can find more information in the following chapters.

9.1.1 SB6 drive controller – X20

The maximum and minimum conductor cross-sections of the end sleeve with plastic collar as well as the required insulation stripping length for the motor connection to terminal X20 can be found in the following table.

Type	Max. conductor cross-section	Min. conductor cross-section	Insulation stripping length
SB6A06	2.5 mm ²	0.25 mm ²	10 mm
SB6A16	4 mm ²	0.25 mm ²	12 – 15 mm
SB6A26	10 mm ²	0.75 mm ²	18 mm

Tab. 102: SB6 drive controllers, X20 motor connection terminal specification

9.1.2 SC6 drive controller – X20

The maximum and minimum conductor cross-sections of the end sleeve with plastic collar as well as the required insulation stripping length for the motor connection to terminal X20 can be found in the following table.

Type	Max. conductor cross-section	Min. conductor cross-section	Insulation stripping length
SC6A062	2.5 mm ²	0.25 mm ²	10 mm
SC6A162	4 mm ²	0.25 mm ²	12 – 15 mm
SC6A261			

Tab. 103: SC6 drive controllers, X20 motor connection terminal specification

9.1.3 SI6 drive controller – X20

The maximum and minimum conductor cross-sections of the end sleeve with plastic collar as well as the required insulation stripping length for the motor connection to terminal X20 can be found in the following table.

Type	Max. conductor cross-section	Min. conductor cross-section	Insulation stripping length
SI6A061	2.5 mm ²	0.25 mm ²	10 mm
SI6A062			
SI6A161	4 mm ²	0.25 mm ²	12 – 15 mm
SI6A162			
SI6A261			
SI6A262	10 mm ²	0.75 mm ²	18 mm
SI6A361			

Tab. 104: SI6 drive controllers, X20 motor connection terminal specification

9.1.4 SD6 drive controller – X20

The maximum and minimum conductor cross-sections of the end sleeve with plastic collar as well as the required insulation stripping length for the motor connection to terminal X20 can be found in the following table.

Type	Max. conductor cross-section	Min. conductor cross-section	Insulation stripping length
SD6A02	2.5 mm ²	0.25 mm ²	10 mm
SD6A04			
SD6A06			
SD6A14	4 mm ²	0.25 mm ²	12 – 15 mm
SD6A16			
SD6A24	10 mm ²	0.75 mm ²	18 mm
SD6A26			
SD6A34	35 mm ²	1.5 mm ²	18 mm
SD6A36			
SD6A38			

Tab. 105: SD6 drive controllers, X20 motor connection terminal specification

9.1.5 FDS 5000 frequency inverter – X20

The maximum and minimum conductor cross-sections of the end sleeve with plastic collar as well as the required insulation stripping length for the motor connection to terminal X20 can be found in the following table.

Type	Max. conductor cross-section	Min. conductor cross-section	Insulation stripping length
FDS 5004A	2.5 mm ²	0.25 mm ²	10 mm
FDS 5007A			
FDS 5008A			
FDS 5015A			
FDS 5022A	4 mm ²	0.25 mm ²	12 – 15 mm
FDS 5040A			
FDS 5055A			
FDS 5075A			

Tab. 106: FDS 5000 servo inverter, X20 motor connection terminal specification

9.1.6 MDS 5000 servo inverter – X20

The maximum and minimum conductor cross-sections of the end sleeve with plastic collar as well as the required insulation stripping length for the motor connection to terminal X20 can be found in the following table.

Type	Max. conductor cross-section	Min. conductor cross-section	Insulation stripping length
MDS 5007A	2.5 mm ²	0.25 mm ²	10 mm
MDS 5008A			
MDS 5015A			
MDS 5040A	4 mm ²	0.25 mm ²	12 – 15 mm
MDS 5075A			
MDS 5110A	10 mm ²	0.75 mm ²	18 mm
MDS 5150A			
MDS 5220A	35 mm ²	1.5 mm ²	18 mm
MDS 5370A			
MDS 5450A			

Tab. 107: MDS 5000 servo inverter, X20 motor connection terminal specification

9.1.7 SDS 5000 servo inverter – X20

The maximum and minimum conductor cross-sections of the end sleeve with plastic collar as well as the required insulation stripping length for the motor connection to terminal X20 can be found in the following table.

Type	Max. conductor cross-section	Min. conductor cross-section	Insulation stripping length
SDS 5007A	2.5 mm ²	0.25 mm ²	10 mm
SDS 5008A			
SDS 5015A			
SDS 5040A	4 mm ²	0.25 mm ²	12 – 15 mm
SDS 5075A			
SDS 5110A	10 mm ²	0.75 mm ²	18 mm
SDS 5150A			
SDS 5220A	35 mm ²	1.5 mm ²	18 mm
SDS 5370A			
SDS 5450A			

Tab. 108: SDS 5000 servo inverter, X20 motor connection terminal specification

9.2 EMC recommendations

Information

The following information on EMC-compliant installation is only a recommendation. Depending on the application, the ambient conditions as well as the legal requirements, measures beyond these recommendations may be required.

Lay the power line, power cable and signal lines separately from each other, e.g. in separate cable ducts.

Only use shielded, low-capacitance cables as power cables.

If the brake line is carried in the power cable, it must be shielded separately.

Ground and insulate free line ends if they cannot be connected to the terminals provided for this purpose on the drive controller, e.g. using a connecting terminal.

Connect the shield of the power cable to the grounding conductor system over a wide area and in the immediate vicinity of the drive controller. For this purpose, use the shield contact provided for the drive controllers or suitable accessories.

The connection lines for braking resistors as well as the cores of the Quick DC-Link modules must be implemented as twisted pairs. At line lengths of 30 cm or more, the lines also must be implemented with shielding and the shield must be applied over a wide area in the immediate vicinity of the drive controller.

For motors with terminal boxes, connect the shield to the terminal box over large contact areas. For example, use EMC cable glands.

Connect the shield of the control lines on one side to the reference potential of the source, e.g. the PLC or CNC.

You may use chokes to improve the EMC and protect the drive system. Power chokes are used to dampen voltage and current peaks and reduce the load of the power feed-in of the drive controllers or supply modules. Output chokes reduce current peaks caused by line capacity at the power output of the drive controller.

9.3 Detailed information

Motor connection plans and current document versions of the drive controller manuals can be found at:

<http://www.stoeber.de/en/downloads/>.

Enter the ID of the documentation in the search.

If you do not know the ID of the motor connection plan, first select the desired language of the document as well as "connection plan" as the download type for the search to limit the search results. Then enter the drive controller series (e.g. "SD6") or the motor type (e.g. "EZ") in the search field.

In the following table you can find the IDs of the manuals for the drive controllers:

Title	Documentation	Contents	ID
SB6 drive controller	Manual	System design, technical data, project configuration, storage, installation, connection, commissioning, operation, service, diagnostics	443340
SC6 drive controller	Manual	System design, technical data, project configuration, storage, installation, connection, commissioning, operation, service, diagnostics	442790
Multi-axis drive system with SI6 and PS6	Manual	System design, technical data, project configuration, storage, installation, connection, commissioning, operation, service, diagnostics	442728
SD6 drive controller	Manual	System design, technical data, project configuration, storage, installation, connection, commissioning, operation, service, diagnostics	442426
FDS 5000 frequency inverter	Configuration manual	Technical data, installation and connection	442269
MDS 5000 servo inverter	Configuration manual	Technical data, installation and connection	442273
SDS 5000 servo inverter	Configuration manual	Technical data, installation and connection	442277

9.4 Formula symbols

Symbol	Unit	Explanation
$\Delta\vartheta$	K	Temperature difference
d_{out}	mm	Outer diameter
I_0	A	Stall current
$I_{N,CAB}$	A	Nominal current of the cable
$I_{N,MF}$	A	Nominal current of the choke or motor filter
K_{EM}	V/1000 rpm	Voltage constant: peak value of the induced voltage between the phases U, V, W of the motor at operating temperature at a speed of 1000 rpm
M_N	Nm	Nominal torque
n_N	rpm	Nominal speed: The speed for which the nominal torque M_N is specified

10 Contact

10.1 Consultation, service and address

We would be happy to help you!

We offer a wealth of information and services to go with our products on our website:

<http://www.stoeber.de/en/service>

For additional or personalized information, contact our consultation and support service:

<http://www.stoeber.de/en/support>

If you need our system support:

Phone: +49 7231 582-3060

systemsupport@stoeber.de

If you need a replacement device:

Phone: +49 7231 582-1128

replace@stoeber.de

Call our 24-hour service hotline:

Phone: +49 7231 582-3000

Our address is:

STÖBER Antriebstechnik GmbH + Co. KG

Kieselbronner Strasse 12

75177 Pforzheim, Germany

10.2 Your opinion is important to us

We created this documentation to the best of our knowledge with the goal of helping you build and expand your expertise productively and efficiently with our products.

Your suggestions, opinions, wishes and constructive criticism help us to ensure and further develop the quality of our documentation.

If you want to contact us for a specific reason, we would be happy to receive an e-mail from you at:

documentation@stoeber.de

Thank you for your interest.

Your STÖBER editorial team

10.3 Close to customers around the world

We offer you committed, expert advice and support in over 40 countries worldwide:

STOBER AUSTRIA

www.stoeber.at
+43 7613 7600-0
sales@stoeber.at

STOBER FRANCE

www.stober.fr
+33 478 98 91 80
sales@stober.fr

STOBER ITALY

www.stober.it
+39 02 93909570
sales@stober.it

STOBER KOREA

www.stober.kr
+82 10 5681 6298
sales@stober.kr

STOBER SWITZERLAND

www.stoeber.ch
+41 56 496 96 50
sales@stoeber.ch

STOBER TURKEY

www.stober.com
+90 216 510 2290
sales-turkey@stober.com

STOBER USA

www.stober.com
+1 606 759 5090
sales@stober.com

STOBER CHINA

www.stoeber.cn
+86 512 5320 8850
sales@stoeber.cn

STOBER Germany

www.stoeber.de
+49 7231 582-0
sales@stoeber.de

STOBER JAPAN

www.stober.co.jp
+81-3-5875-7583
sales@stober.co.jp

STOBER SWEDEN

www.stober.com
+46 702 394 675
neil.arstad@stoeber.de

STOBER TAIWAN

www.stober.tw
+886 4 2358 6089
sales@stober.tw

STOBER UK

www.stober.co.uk
+44 1543 458 858
sales@stober.co.uk

Glossary

Banding

Wrapping of a core bundle with relatively thin non-woven strips.

Bending radius

In the cabling, the slightest bend that a cable is allowed to have when routed. The radii are specified in relation to the cable diameter and depend on the design.

Bending resistance

Resistance to bending stress.

Current carrying capacity

Maximum permitted current that can be transmitted under specified conditions.

DC resistance

Overall sum of DC loop resistance of both wires of a pair.

Drag chain

Component in mechanical engineering that guides and protects flexible cables, pneumatic or hydraulic lines.

Outer sheath

Closed shell of the cable for the protection of the structural elements underneath.

Output choke

Choke type that delays the current increase at the input of the drive controller or supply module in order to reduce the harmonics in the supply grid and reduces the load of the power feed-in of the devices.

Pilot core

Individual core used for information transmission.

Plug connectors

Component for disconnecting and connecting cables. The connecting parts are appropriately aligned by the positive locking of the plug pieces, feature detachable, positive attachment by spring force (pin) and are often also secured against unintended disconnection by a screw connection.

Power core

Individual core used for power transmission.

Tensile stress

Type of loading in which a body is subjected to tensile stress.

Test voltage

Value specified by the manufacturer for an impulse withstand voltage that the insulation withstands temporarily.

List of figures

Fig. 1	Length definition for ready-made encoder cables	12
Fig. 2	Length definition for ready-made power cables – SB6, SC6, SI6.....	12
Fig. 3	Length definition for ready-made power cables – FDS 5000, MDS 5000, SDS 5000 and SD6.....	12
Fig. 4	Length definition for ready-made hybrid cables	12
Fig. 5	TEP dimensional drawing	101
Fig. 6	TEP dimensional drawing	117

List of tables

Tab. 1	con.15 encoder cable pin assignment, EnDat 2.1/2.2 digital	14
Tab. 2	con.15 connector dimensions	14
Tab. 3	con.17 encoder cable pin assignment, EnDat 2.1/2.2 digital	15
Tab. 4	con.17 connector dimensions	15
Tab. 5	con.23 encoder cable pin assignment, EnDat 2.1/2.2 digital	16
Tab. 6	con.23 plug dimensions.....	16
Tab. 7	con.23 encoder cable pin assignment, incremental HTL.....	20
Tab. 8	con.23 plug dimensions.....	20
Tab. 9	HT6 connection description for HTL differential encoder (15-pin to 15-pin).....	21
Tab. 10	con.23 encoder cable pin assignment, SSI	25
Tab. 11	con.23 plug dimensions.....	25
Tab. 12	Encoder cable pin assignment con.15, resolver, "Motion Resolver" cable label	30
Tab. 13	con.15 connector dimensions	30
Tab. 14	Encoder cable pin assignment con.17, resolver, "Motion Resolver" cable label	31
Tab. 15	con.17 connector dimensions	31
Tab. 16	Encoder cable pin assignment con.23, resolver, "Motion Resolver" cable label	32
Tab. 17	con.23 plug dimensions.....	32
Tab. 18	Encoder cable pin assignment con.15, resolver, "No. 44206" cable label	33
Tab. 19	con.15 connector dimensions	33
Tab. 20	Encoder cable pin assignment con.17, resolver, "No. 44206" cable label	34
Tab. 21	con.17 connector dimensions	34
Tab. 22	Encoder cable pin assignment con.23, resolver, "No. 44206" cable label	35
Tab. 23	con.23 plug dimensions.....	35
Tab. 24	AP6A00 connection description for resolver (9-pin to 15-pin)	36
Tab. 25	AP6A01 connection description for the resolver and motor temperature sensor (9-pin to 15-pin)	37
Tab. 26	con.15 encoder cable pin assignment, EnDat 2.1 sin/cos	42
Tab. 27	con.15 connector dimensions	42
Tab. 28	con.17 encoder cable pin assignment, EnDat 2.1 sin/cos	43
Tab. 29	con.17 connector dimensions	43
Tab. 30	con.23 encoder cable pin assignment, EnDat 2.1 sin/cos	44
Tab. 31	con.23 plug dimensions.....	44
Tab. 32	AP6A02 connection description for EnDat 2.1 sin/cos encoder and motor temperature sensor (15-pin to 15-pin).....	45
Tab. 33	Encoder cable codes for EZ, EZHD, EZM and EZS synchronous servo motors.....	49
Tab. 34	Extension cable codes for EZ, EZHD, EZM and EZS synchronous servo motors	49

Tab. 35	Encoder cable codes for ED and EK synchronous servo motors	50
Tab. 36	Extension cable codes for ED and EK synchronous servo motors	50
Tab. 37	Encoder cable codes for IE2, IE3 asynchronous motors.....	51
Tab. 38	Extension cable codes for IE2, IE3 asynchronous motors	51
Tab. 39	Ready-made cables up to 100 m for EnDat 2.1/2.2 digital encoders	52
Tab. 40	Ready-made extension cables up to 100 m for EnDat 2.1/2.2 digital encoders	52
Tab. 41	Ready-made cables up to 100 m for HTL incremental encoders	53
Tab. 42	Ready-made cables up to 100 m for resolvers	53
Tab. 43	Ready-made extension cables up to 100 m for resolvers	53
Tab. 44	Ready-made cables up to 100 m for EnDat 2.1 sin/cos encoders	54
Tab. 45	Ready-made extension cables up to 100 m for EnDat 2.1 sin/cos encoders	54
Tab. 46	Identification numbers of service packs for encoder cables	55
Tab. 47	Maximum cable length of the power cable [m]	62
Tab. 48	con.15 power cable pin assignment.....	63
Tab. 49	con.15 connector dimensions	63
Tab. 50	con.23 power cable pin assignment.....	64
Tab. 51	con.23 connector dimensions	64
Tab. 52	con.40 power cable pin assignment.....	65
Tab. 53	con.40 connector dimensions	65
Tab. 54	con.58 power cable pin assignment.....	66
Tab. 55	con.58 connector dimensions	66
Tab. 56	Assignment of asynchronous motor (4-pole) to minimum cross-section	74
Tab. 57	Non-terminated power cables up to 100 m	76
Tab. 58	Plug connector size and minimum cross-section, EZ synchronous servo motors with convection cooling....	78
Tab. 59	Plug connector size and minimum cross-section, EZ synchronous servo motors with forced ventilation	80
Tab. 60	Plug connector size and minimum cross-section, EZHD synchronous servo motors with convection cooling	81
Tab. 61	Plug connector size and minimum cross-section, EZHP synchronous servo motors with convection cooling	82
Tab. 62	Plug connector size and minimum cross-section, EZM synchronous servo motors with convection cooling	83
Tab. 63	Plug connector size and minimum cross-section, EZS synchronous servo motors with convection cooling ..	84
Tab. 64	Plug connector size and minimum cross-section, EZS synchronous servo motors with forced ventilation....	84
Tab. 65	Plug connector size and minimum cross-section, ED synchronous servo motors with convection cooling ...	85
Tab. 66	Plug connector size and minimum cross-section, ED synchronous servo motors with forced ventilation	86
Tab. 67	Plug connector size and minimum cross-section, EK synchronous servo motors with convection cooling....	87
Tab. 68	Plug connector size and minimum cross-section, EK synchronous servo motors with forced ventilation	87
Tab. 69	Plug connector size and minimum cross-section, Lean motors	88
Tab. 70	Power cable codes for EZ, EZHD, EZHP, EZS and EZM synchronous servo motors, con.15.....	90

Tab. 71	Extension cable codes for EZ, EZHD, EZM and EZS synchronous servo motors, con.15.....	90
Tab. 72	Power cable codes for EZ, EZHD, EZHP, EZS and EZM synchronous servo motors, con.23.....	90
Tab. 73	Extension cable codes for EZ, EZHD, EZHP, EZS and EZM synchronous servo motors, con.23	91
Tab. 74	Power cable codes for EZ, EZHD, EZHP, EZS and EZM synchronous servo motors, con.40.....	91
Tab. 75	Extension cable codes for EZ, EZHD, EZHP, EZS and EZM synchronous servo motors, con.40	91
Tab. 76	Power cable codes for ED, EK synchronous servo motors, con.23.....	92
Tab. 77	Extension cable codes for ED, EK synchronous servo motors, con.23	92
Tab. 78	Power cable codes for ED, EK synchronous servo motors, con.40.....	93
Tab. 79	Extension cable codes for ED, EK synchronous servo motors, con.40	93
Tab. 80	Power cable codes for ED, EK synchronous servo motors, con.58.....	93
Tab. 81	Power cable codes for LM Lean motors, con.23	94
Tab. 82	Extension cable codes for LM Lean motors, con.23	94
Tab. 83	Ready-made power cables up to 25 m.....	96
Tab. 84	Ready-made power cables from 30 m	97
Tab. 85	Ready-made extension cables for power cables up to 25 m.....	98
Tab. 86	Ready-made extension cables for power cables from 30 m	98
Tab. 87	Identification numbers of service packs for power cables.....	99
Tab. 88	TEP technical data	100
Tab. 89	TEP dimensions and weight.....	101
Tab. 90	con.23 hybrid cable pin assignment.....	103
Tab. 91	con.23 connector dimensions	103
Tab. 92	Plug connector size and minimum cross-section, EZ synchronous servo motors with convection cooling	110
Tab. 93	Plug connector size and minimum cross-section, EZ synchronous servo motors with forced ventilation	111
Tab. 94	Plug connector size and minimum cross-section, EZS synchronous servo motors with convection cooling ..	112
Tab. 95	Plug connector size and minimum cross-section, EZS synchronous servo motors with forced ventilation....	112
Tab. 96	Hybrid cable codes for EZ and EZS synchronous servo motors, con.23	114
Tab. 97	Ready-made OCS-Basic hybrid cables up to 12.5 m	115
Tab. 98	Ready-made OCS-Advanced hybrid cables up to 25 m	115
Tab. 99	Ready-made OCS-Advanced hybrid cables from 30 m	115
Tab. 100	TEP technical data	116
Tab. 101	TEP dimensions and weight.....	117
Tab. 102	SB6 drive controllers, X20 motor connection terminal specification.....	118
Tab. 103	SC6 drive controllers, X20 motor connection terminal specification.....	118
Tab. 104	SI6 drive controllers, X20 motor connection terminal specification	119
Tab. 105	SD6 drive controllers, X20 motor connection terminal specification	119
Tab. 106	FDS 5000 servo inverter, X20 motor connection terminal specification.....	120

Tab. 107	MDS 5000 servo inverter, X20 motor connection terminal specification	120
Tab. 108	SDS 5000 servo inverter, X20 motor connection terminal specification.....	121

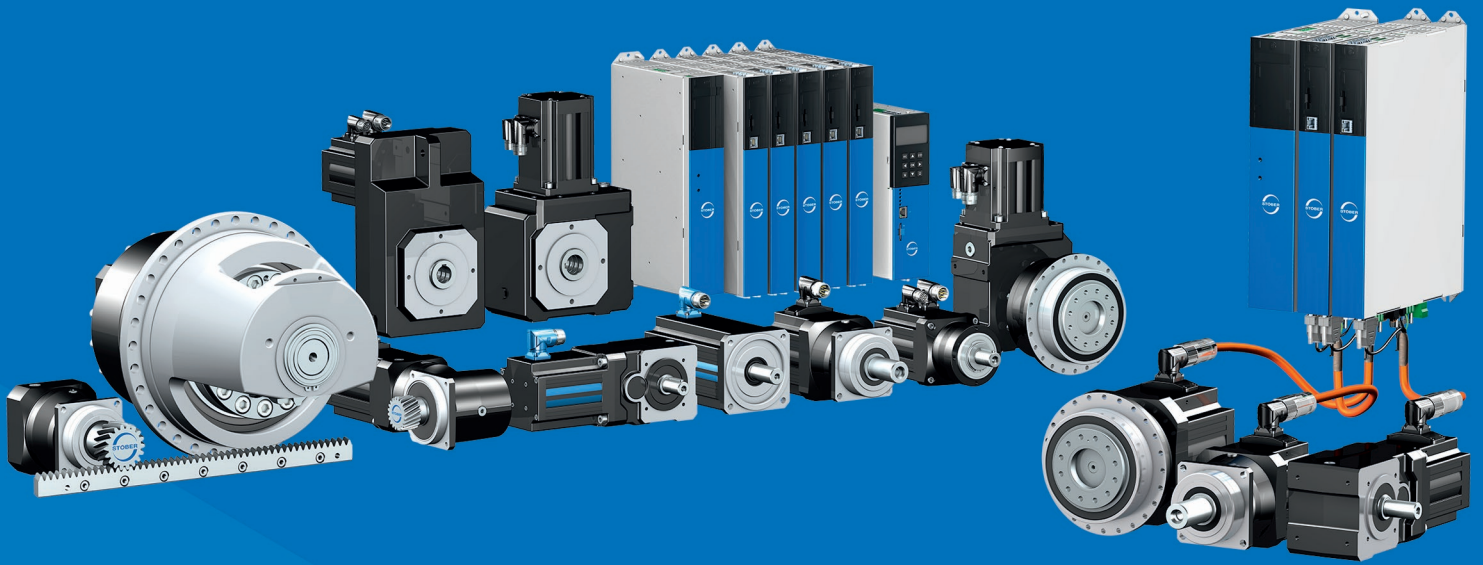

4 4 3 1 0 2 . 0 6

04/2026

STÖBER Antriebstechnik GmbH + Co. KG
Kieselbronner Str. 12
75177 Pforzheim
Germany
Tel. +49 7231 582-0
mail@stoeber.de
www.stober.com

24 h Service Hotline
+49 7231 582-3000

www.stober.com