

PE Series: INLINE — Shaft Output

PE Features

- 3:1 to 100:1 ratios
- Helical gearing produces more torque while running quieter compared to spur tooth gearing
- Input coupling design transfers more torque with lower inertia for vibration free operation
- Large motor input option to accept bigger diameter motor shafts so you don't use an oversized gearbox
- Error free motor mounting and quick changeover with toleranced pilot on motor plate
- Low no load running torque, giving you more torque for your application
- Optional food grade grease (Contact STÖBER.)
- Build and ship in one day
- Assembled in the USA

STÖBER PE Series Servo Precision Planetary Gearheads are available for applications where very low backlash is not important. They are an economical helical tooth planetary, comparable in quality to other STÖBER units. Every gearbox is made to order. STÖBER will custom whatever you need to fit your application. Contact us today to learn more

**SHIPS in
1 DAY!**
NO EXPEDITE FEE FOR 24
HOUR SERVICE



General Specifications

Ambient Temperature	0°C to +40°C (104°F) [Unit temperature <90°C Max]
Backlash	≤8 arcmins, see performance overview chart page
Coating	Black (RAL-9005)
Degree of Protection	IP64
Direction of Rotation	Input and output rotate the SAME direction
Efficiency	1 stage 97%; 2 stage 95%
Input RPM	Up to 8,000 RPM
Installation	Requires 10.9 fasteners. See page 288 for more information
Grease	Synthetic grease (NLGI 2)/ Food grease - lubricated for life
Mounting Position	Unrestricted
Warranty	5 Year Limited (2 Years on normal wear items: bearings, seals, etc.)

Options

Large Input (MEL)

- Accommodates a larger diameter motor shaft without going to a larger size gearbox.

Coating Option

- Available with multi-layer, industrial 316 stainless steel epoxy coating. Contact factory for this option.



Overview

Selection Options At-a-Glance

Using the **Selection Data** table later in this section, select the PE Series Gearhead with the appropriate performance and design options tailored to your motor choice and exact application requirements. Use the part number guide below as a reference to build a part number for the complete gearhead assembly.

Part Number Examples: 1 2 3 4 5 6 7 8 9 10
PE 3 2 1 S P S S 0030 ME

	Design Option	Part Number Code	Description
1	Series	PE	Economical planetary
2	Size	2 3 4 5	4 sizes of gearhead
3	Generation	2	Version of gearhead
4	# of Stages	1 2	One stage for ratios of ≤ 10:1 Two stage for ratios >10:1
5	Housing	S	Standard mounting style
6	Output	P	Shaft with key
7	Bearings	S	Standard
8	Backlash	S	Standard Backlash
9	Ratio	0030	Ratios range from 3:1 to 100:1 (0030=3:1; 0200=20:1; 1000=100:1, etc.)
10	Motor Adapter	ME MEL	Motor adapter w/standard input* Motor adapter w/large Input* *See Motor Mounting Plate Option, page 64

PE Series: INLINE — Shaft Output

PE Series Performance Overview

PE Series performance is dependent on several factors including duty cycle, bearing design, gearhead size and stage configuration, among others. Use the chart below for preliminary evaluation, then use the following performance chart and selection information on the following pages for specific performance sizing and selection.

	Size/Generation	PE22		PE32		PE42		PE52	
		# of Stages	1	2	1	2	1	2	1
Permissible Acceleration Torque $M_{2ACC\text{MAX}}$	Nm	20	20	53	50	109	104	250	250
Output Torque Nom. ¹⁾ $M_{2N\text{MAX}}$	Nm	8	10	26	30	60	65	130	160
Torsional Stiffness $C_{2\text{MAX}}$	Nm/arcmin	1.4	1.4	4.4	4.2	14	13	35	33
Torsional Backlash ²⁾ $\Delta\phi$	arcmin	≤10	≤13	≤8	≤10	≤8	≤10	≤8	≤10
Input Speed Max. $n_{1\text{MAX}}$	Continuous Cyclic	4500 8000		4000 7000	4500 8000	3600 6000	4000 7000	3000 5000	3600 6000
Efficiency (@nom torque)	%	1 Stage = 97; 2 Stage = 95							
Weight	kg lbs	1.3 2.87	1.4 3.09	2.5 5.51	2.4 5.29	4.7 10.36	5.1 11.24	8.8 19.40	10.0 22.05
Noise ³⁾	dB(A)	≤60	≤60	≤62	≤61	≤64	≤63	≤65	≤64

¹⁾ Ratings based on input speed (n_1) of 1500 RPM.

For torque at higher input speeds (M_{2NX}) solve the formula:
where n_1 = Actual Input Speed.

$$M_{2NX} = \frac{M_{2N}}{\sqrt[3]{\frac{n_1}{1500}}}$$

²⁾ Tested at 1.5% of nominal torque and recorded on the output side of the gearhead. For lower backlash, contact STÖBER technical support.

³⁾ Measurement at one (1) meter distance with input speed (n_1) of 2000 RPM.

PE Series: INLINE — Shaft Output

PE Series Motor Mounting Plate Option (Motor information required with Motor Adapter option)

STOBER Servo Gearheads fit the motor of your choice with the appropriate motor mounting plate assembled between the motor and the gearhead.

NOTE: When ordering a gearhead:

- Specify the motor manufacturer and part number
- Provide the motor drawing with dimensions, or specify the motor mounting dimensions (per the list shown at right)

For a precise dimension on a specific motor, or for general assistance, we recommend you contact STOBER Technical Support.

Customer Required Dimensions for Properly Sized Motor Mounting Plate

d2	Motor Shaft Diameter (If an adapter bushing is required it will be supplied with the motor plate.)
b6	Pilot Diameter
e6	Bolt Circle Diameter
s6	Bolt Diameter
l5	Motor Shaft Length
f6	Pilot Length
a6	Square Flange (Optional – motor plate will typically be made to match this dimension.)

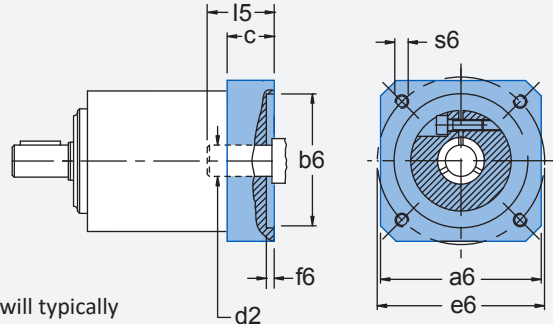

Motor Mounting Plate Dimensions — mm (Gearhead Part Number Specific)	PE221	PE221...L	PE321...L	PE421...L	PE521...L
	PE222	PE321	PE421	PE521	PE521...L
PE322	PE422	PE522			
Maximum Allowed Motor Shaft Dia. d2	14	19	24	32	38
Minimum Allowed Motor Plate Thickness c*	15	18	21	24	26

* Note that the c motor plate thickness is determined by the motor shaft length. The minimum motor plate thickness is the value listed.

PE Series Output Shaft Options ("P" designated in part number, for example: PE2215 P 0040 MEL)

P Shaft with Key

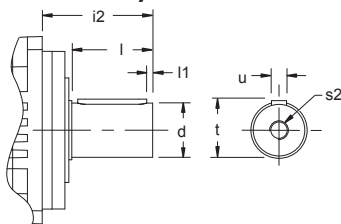

Unit	d k6 mm	i2	l	l1	s2 ⁽¹⁾	t	u ⁽²⁾	
		mm	mm	mm		mm	W x H x L	
PE2	12	+0.012/+0.001	24.5	18	2	M4	13.5	A4x4x14
PE3	16	+0.012/+0.001	36	28	2	M5	18.0	A5x5x22
PE4	22	+0.015/+0.002	46	36	2	M8	24.5	A6x6x32
PE5	32	+0.018/+0.002	70	58	4	M12	35.0	A10x8x50

⁽¹⁾ The center hole in shafts with keys (Option "P") are machined to DIN 332 T2 shape DR.

⁽²⁾ Feather keys are toleranced according to standard DIN 6885.



Overview

Permissible Motor Tilting Torque

The permissible tilting torque of the motor attached to the gear unit is a result of the static and dynamic load "F" from the motor weight, mass acceleration, and vibration multiplied by the distance from the center of gravity "l_s" of the motor.

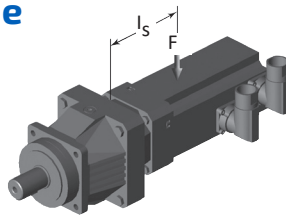

$$M_{1k} = F \times l_s \leq M_{1K}$$

M _{1K}	PE221 PE222 PE322	PE321 PE322	PE421 PE422	PE521
Nm	10	20	40	80

PE Permissible Output Shaft Load and Tilting Moments*

Unit	Z ₂ Distance of Shaft Shoulder to Center of Output Bearing mm	F _{2ax100} Permitted Axial Force N	F _{2rad100} Permitted Radial Force ≤100RPM N	M _{2K100} Permitted Tilting Torque ≤100RPM Nm
PE221, PE222	8	400	800	13
PE321, PE322	11	800	1600	40
PE421, PE422	13	1900	2400	73
PE521, PE522	16	4000	4600	206

* Refer to illustration and definitions below. During EMERGENCY OFF operation (maximum stops per gearhead = 1000) the permissible values in the table for F_{2ax}, F_{2R} and M_{2K} can be multiplied by a factor of 2. Rating based on output speed (n₂) of 100 RPM. For values at other speeds see below.

PE Series: INLINE — Shaft Output

PE Series Load/Life/Speed Calculations

All formulas shown are based on METRIC values

Upper case letters are permissible values. Lower case letters are for existing values.

The permissible load and tilting moment values are based on an output speed of 100 RPM. For higher speeds the following applies, where n₂ is the desired speed:

$$F_{2ax} = \frac{F_{2ax100}}{\sqrt[3]{\frac{n_2}{100}}}, \quad F_{2R} = \frac{F_{2rad100}}{\sqrt[3]{\frac{n_2}{100}}}, \quad M_{2K} = \frac{M_{2K100}}{\sqrt[3]{\frac{n_2}{100}}}$$

The application output tilting moment should be determined by the following formula:

$$M_{2k,acc} = \frac{2 \cdot F_{2ax} \cdot Y_2 + F_{2rad,acc} \cdot (X_2 + Z_2)}{1000} \leq M_{2k,acc}$$

Where:

- Z₂ Distance of Shaft Shoulder to Center of Output Bearing
- n₂ Actual Average Output Speed
- X₂ Distance of the Shaft Shoulder to the Force Application Point
- Y₂ Distance of the Shaft Axis to the Axial Force Application Point
- F_{2ax}* Actual Axial Force at Gear Unit Output
- F_{2ax100} Permitted Axial Force
- F_{2rad100} Permitted Radial Force ≤100RPM
- F_{2rad,acc} Radial Acceleration Force
- F_{2rad,acc}* Radial Acceleration Force at Gear Unit Output
- M_{2K100} Permitted Tilting Torque ≤100RPM
- M_{2K,acc} Permitted Acceleration Tilting Torque
- M_{2k,acc}* Permitted Acceleration Tilting Torque at Gear Unit Output
- C_{2K} Tilting Stiffness

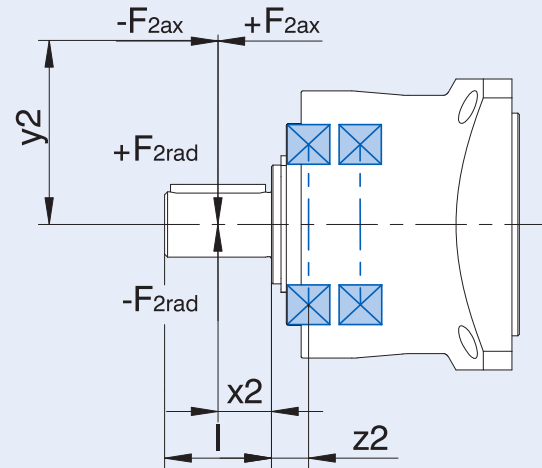

The following apply to the bearing service life L_{10h} (ED₁₀ ≤ 40%):

- L_{10h} > 10,000h with 1 < M_{2kN}/M_{2k*} < 1.25
- L_{10h} > 20,000h with 1.25 < M_{2kN}/M_{2k*} < 1.5
- L_{10h} > 30,000h with 1.5 < M_{2kN}/M_{2k*}

For different duty cycles:

$$L_{10h} > L_{10h(ED_{10}=40\%)} \cdot (40\%/ED_{10})$$

PE Series: INLINE – Shaft Output

Exact Ratio (i)	Output Torque			Back-lash $\Delta\phi_2$ arcmin	Part Number* (Gearhead + Input)	Max. Input Speed RPM (n1)		Motor Shaft Max ϕ d_{MW} mm	Input Inertia ³⁾ J_1 kgcm ²	Tors. Stiffness C_2 Nm/arcmin	Oper. Noise L_{pA} dB(A)
	Nom. ¹⁾ M_{ZN}	Accel. M_{Zacc}	Peak ²⁾ M_{ZNOT}			Cont.	Cyclic				
	Nm	Nm	Nm								

PE2

4.000	8.0	20	32	10	PE221_0040 ME	4000	8000	≤14	0.12	1.4	60
					PE221_0040 MEL			≤19	0.41		
5.000	8.0	20	32	10	PE221_0050 ME	4000	8000	≤14	0.11	1.4	58
					PE221_0050 MEL			≤19	0.40		
7.000	8.0	18	32	10	PE221_0070 ME	4500	8000	≤14	0.10	1.3	56
					PE221_0070 MEL			≤19	0.39		
10.00	8.0	17	32	10	PE221_0100 ME	4500	8000	≤14	0.10	1.2	54
					PE221_0100 MEL			≤19	0.39		
16.00	10	19	32	13	PE222_0160 ME	4000	8000	≤14	0.14	1.4	60
					PE222_0160 MEL			≤19	0.42		
20.00	10	20	32	13	PE222_0200 ME	4000	8000	≤14	0.12	1.4	60
					PE222_0200 MEL			≤19	0.41		
25.00	10	20	32	13	PE222_0250 ME	4000	8000	≤14	0.12	1.4	59
					PE222_0250 MEL			≤19	0.41		
28.00	10	19	32	13	PE222_0280 ME	4000	8000	≤14	0.11	1.4	59
					PE222_0280 MEL			≤19	0.40		
35.00	10	20	32	13	PE222_0350 ME	4000	8000	≤14	0.11	1.4	58
					PE222_0350 MEL			≤19	0.40		
40.00	10	19	32	13	PE222_0400 ME	4500	8000	≤14	0.10	1.4	58
					PE222_0400 MEL			≤19	0.39		
50.00	10	20	32	13	PE222_0500 ME	4500	8000	≤14	0.10	1.4	57
					PE222_0500 MEL			≤19	0.39		
70.00	10	18	32	13	PE222_0700 ME	4500	8000	≤14	0.10	1.3	56
					PE222_0700 MEL			≤19	0.39		
100.0	10	17	32	13	PE222_1000 ME	4500	8000	≤14	0.10	1.2	55
					PE222_1000 MEL			≤19	0.39		

¹⁾ Based on input speed of 1500 RPM. See page 63 for details on torque calculations.

²⁾ Maximum momentary torque for emergency stops or heavy shock load. (Admissible stops per life of gearhead = 1,000 stops maximum.)

³⁾ Inertia based on maximum input. For lower inertia, using smaller diameter input, contact STÖBER.

* ME = Motor Accurate L = Large Input Option



Selection Data

Exact Ratio (i)	Output Torque			Back-lash $\Delta\phi_2$ arcmin	Part Number* (Gearhead + Input)	Max. Input Speed RPM (n1)		Motor Shaft Max ϕ d_{MW} mm	Input Inertia ³⁾ J_1 kgcm ²	Tors. Stiffness C_2 Nm/arcmin	Oper. Noise L_{pA} dB(A)
	Nom. ¹⁾ M_{2N} Nm	Accel. M_{2acc} Nm	Peak ²⁾ M_{2NOT} Nm			Cont.	Cyclic				

PE3

3.000	21	40	80	8	PE321_0030 ME	3500	6000	≤ 19	0.56	3.4	62
					PE321_0030 MEL			≤ 24	0.99		
4.000	24	46	90	8	PE321_0040 ME	3700	7000	≤ 19	0.47	4.3	61
					PE321_0040 MEL			≤ 24	0.90		
5.000	25	53	90	8	PE321_0050 ME	3700	7000	≤ 19	0.44	4.4	59
					PE321_0050 MEL			≤ 24	0.87		
7.000	26	50	90	8	PE321_0070 ME	4000	7000	≤ 19	0.41	4.1	57
					PE321_0070 MEL			≤ 24	0.84		
10.00	26	48	90	8	PE321_0100 ME	4000	7000	≤ 19	0.40	3.7	55
					PE321_0100 MEL			≤ 24	0.83		
16.00	30	45	90	10	PE322_0160 ME	4000	8000	≤ 14	0.16	4.0	61
					PE322_0160 MEL			≤ 19	0.45		
20.00	30	50	90	10	PE322_0200 ME	4000	8000	≤ 14	0.16	4.0	61
					PE322_0200 MEL			≤ 19	0.44		
25.00	30	50	90	10	PE322_0250 ME	4000	8000	≤ 14	0.13	4.2	60
					PE322_0250 MEL			≤ 19	0.42		
28.00	30	44	88	10	PE322_0280 ME	4000	8000	≤ 14	0.12	4.0	60
					PE322_0280 MEL			≤ 19	0.40		
35.00	30	50	90	10	PE322_0350 ME	4000	8000	≤ 14	0.11	4.2	59
					PE322_0350 MEL			≤ 19	0.40		
40.00	30	44	88	10	PE322_0400 ME	4500	8000	≤ 14	0.10	3.9	59
					PE322_0400 MEL			≤ 19	0.39		
50.00	30	50	90	10	PE322_0500 ME	4500	8000	≤ 14	0.10	4.1	58
					PE322_0500 MEL			≤ 19	0.39		
70.00	30	50	90	10	PE322_0700 ME	4500	8000	≤ 14	0.10	4.0	57
					PE322_0700 MEL			≤ 19	0.39		
100.0	30	48	90	10	PE322_1000 ME	4500	8000	≤ 14	0.10	3.6	56
					PE322_1000 MEL			≤ 19	0.39		

PE Series: INLINE — Shaft Output

¹⁾ Based on input speed of 1500 RPM. See page 63 for details on torque calculations.

²⁾ Maximum momentary torque for emergency stops or heavy shock load. (Admissible stops per life of gearhead = 1,000 stops maximum.)

³⁾ Inertia based on maximum input. For lower inertia, using smaller diameter input, contact STÖBER.

* ME = Motor Accurate L = Large Input Option

PE Series: INLINE – Shaft Output

Exact Ratio (i)	Output Torque			Back-lash $\Delta\phi_2$ arcmin	Part Number* (Gearhead + Input)	Max. Input Speed RPM (n1)		Motor Shaft Max ϕ d_{MW} mm	Input Inertia ³⁾ J_1 kgcm ²	Tors. Stiffness C_2 Nm/arcmin	Oper. Noise L_{pA} dB(A)
	Nom. ¹⁾ M_{ZN}	Accel. M_{Zacc}	Peak ²⁾ M_{ZNOT}			Cont.	Cyclic				
	Nm	Nm	Nm								

PE4

3.000	45	90	180	8	PE421_0030 ME	3000	5500	≤ 24	1.4	12	64
					PE421_0030 MEL			≤ 32	3.0		
4.000	55	100	200	8	PE421_0040 ME	3400	6000	≤ 24	1.1	14	63
					PE421_0040 MEL			≤ 32	2.7		
5.000	56	109	200	8	PE421_0050 ME	3400	6000	≤ 24	1.0	14	61
					PE421_0050 MEL			≤ 32	2.6		
7.000	60	100	200	8	PE421_0070 ME	3600	6000	≤ 24	0.91	12	59
					PE421_0070 MEL			≤ 32	2.5		
10.00	60	92	184	8	PE421_0100 ME	3600	6000	≤ 24	0.87	10	57
					PE421_0100 MEL			≤ 32	2.5		
16.00	65	95	190	10	PE422_0160 ME	3700	7000	≤ 19	0.52	13	63
					PE422_0160 MEL			≤ 24	0.95		
20.00	65	104	200	10	PE422_0200 ME	3700	7000	≤ 19	0.51	13	63
					PE422_0200 MEL			≤ 24	0.94		
25.00	65	103	200	10	PE422_0250 ME	3700	7000	≤ 19	0.47	13	62
					PE422_0250 MEL			≤ 24	0.90		
28.00	65	95	190	10	PE422_0280 ME	4000	7000	≤ 19	0.43	13	62
					PE422_0280 MEL			≤ 24	0.86		
35.00	65	103	200	10	PE422_0350 ME	4000	7000	≤ 19	0.42	13	61
					PE422_0350 MEL			≤ 24	0.85		
40.00	65	95	190	10	PE422_0400 ME	4000	7000	≤ 19	0.41	13	61
					PE422_0400 MEL			≤ 24	0.84		
50.00	65	102	200	10	PE422_0500 ME	4000	7000	≤ 19	0.41	13	60
					PE422_0500 MEL			≤ 24	0.83		
70.00	65	90	180	10	PE422_0700 ME	4000	7000	≤ 19	0.42	10	59
					PE422_0700 MEL			≤ 24	0.85		
100.0	65	90	180	10	PE422_1000 ME	4000	7000	≤ 19	0.40	10	58
					PE422_1000 MEL			≤ 24	0.83		

¹⁾ Based on input speed of 1500 RPM. See page 63 for details on torque calculations.

²⁾ Maximum momentary torque for emergency stops or heavy shock load. (Admissible stops per life of gearhead = 1,000 stops maximum.)

³⁾ Inertia based on maximum input. For lower inertia, using smaller diameter input, contact STÖBER.

* ME = Motor Accurate L = Large Input Option



Selection Data

Exact Ratio (i)	Output Torque			Back-lash $\Delta\phi_2$ arcmin	Part Number* (Gearhead + Input)	Max. Input Speed RPM (n1)		Motor Shaft Max ϕ d_{MW} mm	Input Inertia ³⁾ J_1 kgcm ²	Tors. Stiffness C_2 Nm/arcmin	Oper. Noise L_{pA} dB(A)
	Nom. ¹⁾ M_{ZN}	Accel. M_{Zacc}	Peak ²⁾ M_{ZNOT}			Cont.	Cyclic				
	Nm	Nm	Nm								

PE5

3.000	90	180	360	8	PE521_0030 ME	2500	4500	≤ 32	4.4	31	65
					PE521_0030 MEL			≤ 38	7.9		
4.000	130	250	500	8	PE521_0040 ME	2600	5000	≤ 32	3.5	35	64
					PE521_0040 MEL			≤ 38	7.0		
5.000	130	250	500	8	PE521_0050 ME	2600	5000	≤ 32	3.1	35	62
					PE521_0050 MEL			≤ 38	6.6		
7.000	130	250	500	8	PE521_0070 ME	2800	5000	≤ 32	2.8	32	60
					PE521_0070 MEL			≤ 38	6.3		
10.00	130	220	440	8	PE521_0100 ME	3000	5000	≤ 32	2.7	27	58
					PE521_0100 MEL			≤ 38	6.2		
16.00	160	240	480	10	PE522_0160 ME	3400	6000	≤ 24	1.2	33	64
					PE522_0160 MEL			≤ 32	2.8		
20.00	160	250	500	10	PE522_0200 ME	3400	6000	≤ 24	1.2	33	64
					PE522_0200 MEL			≤ 32	2.8		
25.00	160	250	500	10	PE522_0250 ME	3400	6000	≤ 24	1.0	33	63
					PE522_0250 MEL			≤ 32	2.7		
28.00	160	240	480	10	PE522_0280 ME	3600	6000	≤ 24	0.95	33	63
					PE522_0280 MEL			≤ 32	2.6		
35.00	160	250	500	10	PE522_0350 ME	3600	6000	≤ 24	0.94	33	62
					PE522_0350 MEL			≤ 32	2.5		
40.00	160	240	480	10	PE522_0400 ME	3600	6000	≤ 24	0.89	33	62
					PE522_0400 MEL			≤ 32	2.5		
50.00	160	250	500	10	PE522_0500 ME	3600	6000	≤ 24	0.89	33	61
					PE522_0500 MEL			≤ 32	2.5		
70.00	160	220	440	10	PE522_0700 ME	3600	6000	≤ 24	0.93	27	60
					PE522_0700 MEL			≤ 32	2.5		
100.0	160	220	440	10	PE522_1000 ME	3600	6000	≤ 24	0.88	27	59
					PE522_1000 MEL			≤ 32	2.5		

PE Series: INLINE — Shaft Output

¹⁾ Based on input speed of 1500 RPM. See page 63 for details on torque calculations.

²⁾ Maximum momentary torque for emergency stops or heavy shock load. (Admissible stops per life of gearhead = 1,000 stops maximum.)

³⁾ Inertia based on maximum input. For lower inertia, using smaller diameter input, contact STÖBER.

* ME = Motor Accurate L = Large Input Option