

# Drives and automation



## **Drives and automation**

## One partner. All the possibilities.

STOBER has developed and produced excellent drive technology since 1934 and is active internationally with around 1000 employees at 14 locations. STOBER impresses machine manufacturers in wide-ranging industries and markets around the world with tailor-made, highly efficient drive systems for demanding movements.



"Together with our customers, we achieve perfect motion in a wide variety of applications with our precisely coordinated system. Whenever precision, dynamics and quality are required, we are at your side as a reliable partner."

Rainer Wegener, Chief Executive Officer, STÖBER Antriebstechnik

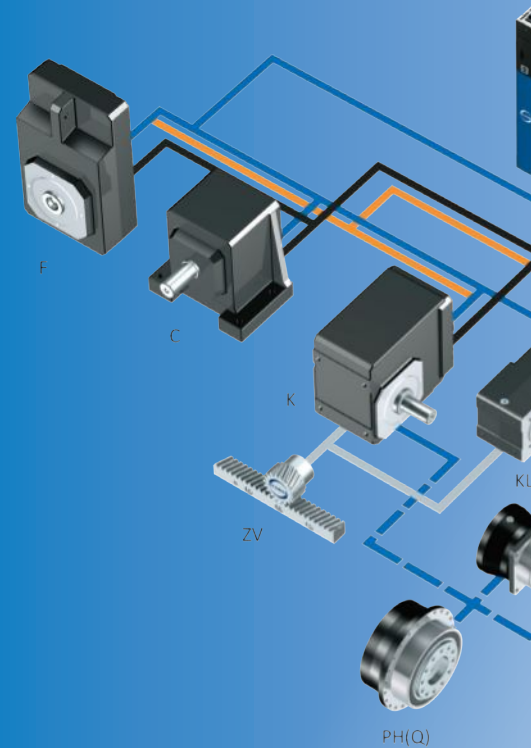

### Drives and automation – what you can expect!

This product catalog presents a perfectly coordinated STOBER system consisting of electronics and motors, connected via ready-to-use STOBER cable technology.

Drive controllers of the 5th and 6th drive controller generation in combination with our highly dynamic synchronous servo motors: a perfect portfolio!

## At home in the world of demanding motion

**Gearboxes**

**Geared motors**

**Motors**

**Cables and drive controllers**

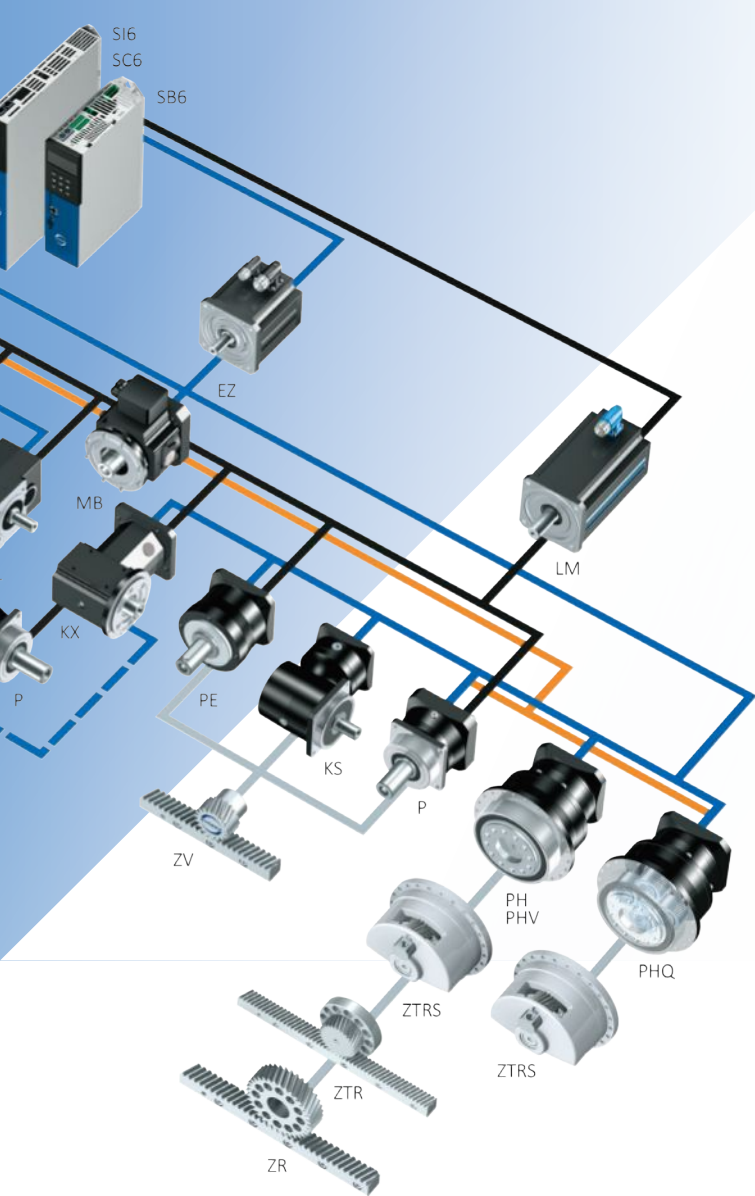

## Everything from a single source.

The STOBER drive system consisting of gearboxes, motors, cables and drive controllers has a modular design and is freely scalable—for tailor-made, compact and powerful machine concepts. It can be adapted to your individual requirements and combined as needed in nearly all industries and applications areas.

We check every single component and how it works together with others, taking on the responsibility for the complete drive train. For you, this means that one contact partner, certified operating safety and maximum availability are guaranteed.

### Need special solutions?

Numerous one-of-a-kind product highlights and project-related adjustments make it possible. With a holistic approach to your specific task, we work together on individualized solutions that are optimally coordinated to your requirements. Dedicated and solution-oriented in the support of your visions and projects.

### STOBER moves integrally and precisely.



"Versatile products, countless possibilities. Your perfect motion is what drives us!"

**Markus Graf, Chief Sales Officer, STÖBER Antriebstechnik**



## STOBER moves as a team and with personality.

As a family-owned company, it is very important to us to maintain close relationships and treat each other with trust. We put people first.

We are committed to the well-being of our employees, identify with the expectations of our customers, and show personal commitment to mutual success.



"We have installed gearboxes, motors and drive controllers from STOBER in nearly all our systems. STOBER supports us in new projects from the first stroke of a pencil in the design phase until commissioning. Our years of cooperation are shaped by openness and honesty and emanate a rather special spirit. The technical consulting, the support—that is real, experienced partnership"

**Jürgen Leicht, Managing Partner of Leicht Stanzautomation**

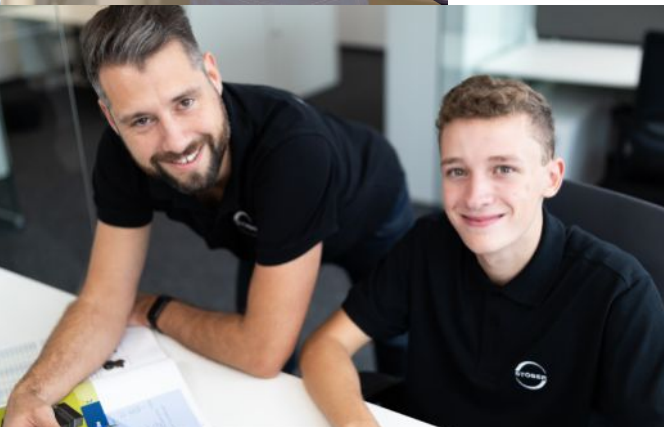

### **Working together. Worldwide. Successfully.**

With an eye to the future, STOBER is facing the challenges of digitalization and investing in integrated solutions and a strong global presence in production, sales and service. STOBER China was founded at the end of 2019. As a result, we are present in more than 40 countries around in the world at 14 locations and with 80 service partners.



**STOBER drives  
Systems technology  
Taicang, China.**



## Table of contents

■	1	Selection tool.....	9
■	2	SB6 drive controllers.....	15
■	3	SC6 drive controllers.....	45
■	4	SI6 drive controllers.....	73
■	5	SD6 drive controllers.....	117
■	6	Connection method.....	157
■	7	EZ synchronous servo motors.....	175
■	8	Close to customers around the world.....	218
■	9	Appendix.....	219

# 1 Selection tool

## 1.1 Drive controllers



SB6

SC6

SI6

SD6

Product chapter

Chapter number

[▶ 2\]](#)

[\[ 3\]](#)

[▶ 4\]](#)

[\[ 5\]](#)

### Technical data

$I_{2N,PU}$	4.5 – 32 A	4.5 – 19 A	5 – 50 A	2.3 – 85 A
$I_{2N,PU}$	3.8 – 20 A	4 – 15 A	4.5 – 40 A	1.7 – 60 A
$I_{2maxPU}$	8.1 – 57.6 A	9.5 – 39.9 A	10.5 – 105 A	4.2 – 153 A
$I_{2maxPU}$	9.5 – 50 A	10 – 37.5 A	11.3 – 100 A	4.3 – 150 A

An explanation of the formula symbols can be found in the chapter [▶ 9.1](#).

### Features

#### Optimal application area

Number of axes	1 – 4	1 – 4	> 4	1 – 8
Application	Drive Based	Drive Based	CiA 402, PROFIdrive	Drive Based Synchronous

#### Motor types

Lean motors	✓	✓	✓	
Asynchronous motors	✓	✓	✓	✓
Synchronous servo motors	✓	✓	✓	✓
Linear motors	✓	✓	✓	✓
Torque motors	✓	✓	✓	✓

#### Encoder interfaces

EnDat 2.2 digital	✓	✓	✓	✓
Incremental	✓	✓	✓	✓
SSI	✓	✓	✓	✓
Resolvers	(✓)	✓	✓	(✓)
Pulse/direction signals	✓	✓	✓	(✓)
EnDat 2.1 sin/cos	(✓)			(✓)
Sin/cos	(✓)			(✓)
EnDat 3 (OCS)	✓	✓	✓	

(✓): Terminal module required

#### Communication

Isochronic system bus (IGB motion bus)				✓
CANopen				(✓)
EtherCAT	✓	✓	✓	(✓)
PROFINET	✓	✓	✓	(✓)

(✓): Communication module required

# 1 Selection tool

## 1.1 Drive controllers



Product chapter

SB6

SC6

SI6

SD6

Chapter number

[ 2 ]

[ 3 ]

[ 4 ]

[ 5 ]

### Features

#### Motor temperature sensor

PTC thermistor

✓

✓

✓

✓

Pt1000 temperature sensor

(✓)

(✓)

(✓)

✓

(✓): OCS required

#### Safety functions

STO, SS1: SIL 3, PL e (cat. 4)

(✓)

(✓)

(✓)

(✓)

SS2, SLS, SBC, SDI, SLI, ...: SIL 3, PL e (cat. 4)

(✓)

(✓)

(✓)

(✓)

(✓): Safety module required

#### Terminals

Base unit

XB6

IO6

RI6

XI6

Digital inputs

4

(8)

8

8

(5)

(5)

(13)

Digital outputs

2

(8)

—

—

(2)

(2)

(10)

Analog inputs

1

(2)

—

—

(2)

(2)

(3)

Analog outputs

—

(2)

—

—

(2)

(2)

(2)

Expanded encoder support

—

(✓)

—

—

—

(✓)

—

(x): Terminal module required

### Features

Multi-axis drive system

✓

Stand-alone

✓

✓

✓

One Cable Solution (OCS)

✓

✓

✓

Double-axis controller available

✓

✓

Live firmware update

✓

✓

✓

✓

Display and keyboard

(✓)

✓

Removable data storage

✓

✓

✓

✓

DC link connection

✓

✓

✓

✓

(✓) Optional

### Applications

Torque/force mode

✓

✓

✓

✓

Velocity mode

✓

✓

✓

✓

Positioning mode

✓

✓

✓

✓

Master/slave mode

(✓)

✓

Interpolating mode

✓

✓

✓

✓

(✓) Terminal module required

### Conformity

cULus

✓

✓

✓

✓

CE

✓

✓

✓

✓

UKCA

✓

✓

# 1 Selection tool

## 1.2 Connection method



Product chapter

Cables

Chapter number

[ 6 ]

### One Cable Solution EnDat 3

<b>Design</b>	<b>Motor plug connector size</b>				
	con.23				
speedtec quick-lock	✓				

Power cores (3 + PE)	Brake cores	Pilot cores	Cable Ø	Bending radius 1 (min.)	Bending radius 2 (min.)
----------------------	-------------	-------------	---------	-------------------------	-------------------------

#### OCS-Basic (up to max. 12.5 m)

4 × 1.0 mm <sup>2</sup>	2 × 0.75 mm <sup>2</sup>	2 × AWG22	Max. 13.6 mm	136.0 mm	68.0 mm
4 × 1.5 mm <sup>2</sup>	2 × 1.0 mm <sup>2</sup>	2 × AWG22	Max. 13.7 mm	137.0 mm	68.5 mm

#### OCS-Advanced (up to 100 m)

4 × 1.5 mm <sup>2</sup>	2 × 0.75 mm <sup>2</sup>	2 × AWG22	Max. 14.7 mm	147.0 mm	73.5 mm
4 × 2.5 mm <sup>2</sup>	2 × 0.75 mm <sup>2</sup>	2 × AWG22	Max. 16.8 mm	168.0 mm	84.0 mm

Bending radius: 1 = free to move, 2 = fixed installation

<b>Other</b>	
Torsional stress	± 30°/m
Bending resistance	✓
Resistant to oil and chemicals	✓

# 1 Selection tool

## 1.2 Connection method



Cables

Product chapter

Chapter number

[ 6 ]

### Power cables

Design	Motor plug connector size		
	con.15	con.23	con.40
Quick-lock	✓		
speedtec quick-lock		✓	✓

Power cores (3 + PE)	Brake cores	Temperature sensor cores	Cable Ø	Bending radius 1 (min.)	Bending radius 2 (min.)
4 × 1.0 mm <sup>2</sup>	2 × 0.5 mm <sup>2</sup>	2 × 0.34 mm <sup>2</sup>	Max. 10.1 mm	101.0 mm	50.5 mm
4 × 1.5 mm <sup>2</sup>	2 × 1.0 mm <sup>2</sup>	2 × 0.5 mm <sup>2</sup>	Max. 12.2 mm	122.0 mm	61.0 mm
4 × 2.5 mm <sup>2</sup>	2 × 1.0 mm <sup>2</sup>	2 × 1.0 mm <sup>2</sup>	Max. 15.1 mm	151.0 mm	75.5 mm
4 × 4.0 mm <sup>2</sup>	2 × 1.5 mm <sup>2</sup>	2 × 1.0 mm <sup>2</sup>	Max. 16.8 mm	168.0 mm	84.0 mm
4 × 10.0 mm <sup>2</sup>	2 × 1.5 mm <sup>2</sup>	2 × 1.0 mm <sup>2</sup>	Max. 22.3 mm	223.0 mm	111.5 mm
4 × 16.0 mm <sup>2</sup>	2 × 1.5 mm <sup>2</sup>	2 × 1.5 mm <sup>2</sup>	Max. 25.0 mm	250.0 mm	125.0 mm

Bending radius: 1 = free to move, 2 = fixed installation

Other	
Torsional stress	± 30°/m
Bending resistance	✓
Resistant to oil and chemicals	✓

# 1 Selection tool

## 1.2 Connection method



Product chapter

Cables

Chapter number

[ 6 ]

### Encoder cables

Design		Motor plug connector size			
		con.15	con.17		
Quick-lock		✓			
speedtec quick-lock			✓		
Encoder		Motor plug connector size			
		con.15	con.17		
EnDat 2.1/2.2 digital encoders		✓	✓		
EnDat 2.1 sin/cos encoders		✓	✓		
Resolver		✓	✓		
Encoder	Supply cores	Pilot cores	Cable Ø	Bending radius 1 (min.)	Bending radius 2 (min.)
EnDat 2.1/2.2 digital	2 × 0.25 mm <sup>2</sup>	3 × 2 × 0.14 mm <sup>2</sup>	Max. 6.7 mm	67.0 mm	33.5 mm
Resolvers	2 × 0.25 mm <sup>2</sup>	3 × 2 × 0.25 mm <sup>2</sup>	Max. 10.3 mm	103.0 mm	51.5 mm
EnDat 2.1 sin/cos	2 × 0.34 mm <sup>2</sup>	2 × 2 × 0.25 mm <sup>2</sup> + 4 × 2 × 0.14 mm <sup>2</sup>	Max. 8.7 mm	87.0 mm	43.5 mm
Bending radius: 1 = free to move, 2 = fixed installation					
Other					
Torsional stress	± 30°/m				
Bending resistance	✓				
Resistant to oil and chemicals	✓				

# 1 Selection tool

## 1.3 Synchronous servo motors



Product chapter

EZ

Chapter number

[ 7 ]

### Technical data

$M_N$	0.4 – 91 Nm
$M_0$	0.44 – 100 Nm

An explanation of the formula symbols can be found in the chapter [▶ 9.1](#).

<b>Shaft design</b>	
Solid shaft without feather key	✓
Solid shaft with feather key	✓
<b>Encoder</b>	
EnDat 3 One Cable Solution (OCS)	✓
EnDat 2.2	✓
EnDat 2.1	✓
Resolvers	✓
<b>Cooling</b>	
Convection cooling	✓
Forced ventilation	✓
<b>Brake</b>	
Permanent magnet holding brake	✓
<b>Marks and test symbols</b>	
CE	✓
cURus	✓
UKCA	✓

## 2 SB6 drive controllers

### Table of contents

2.1	Overview .....	16
2.1.1	Features.....	17
2.1.2	Software components .....	18
2.1.3	Operating motors, encoders and brakes.....	19
2.1.4	Application training.....	19
2.2	Technical data .....	20
2.2.1	Type designation .....	20
2.2.2	Sizes.....	20
2.2.3	General technical data .....	21
2.2.4	Electrical data.....	22
2.2.5	Cycle times .....	26
2.2.6	Derating.....	26
2.2.7	Dimensions.....	28
2.2.8	Weight.....	29
2.2.9	Minimum clearances.....	29
2.3	Drive controller/motor combinations.....	30
2.4	Accessories .....	33
2.4.1	Safety technology.....	33
2.4.2	Communication .....	34
2.4.3	Terminal set.....	34
2.4.4	Terminal module .....	35
2.4.5	Braking resistor .....	36
2.4.6	Choke .....	41
2.4.7	EMC shield plate.....	42
2.5	Further information .....	43
2.5.1	Directives and standards.....	43
2.5.2	Marks and test symbols .....	43
2.5.3	Additional documentation .....	43



## 2 Drive controllers

# SB6

### 2.1 Overview

The universal solution for design freedom

#### Features

- Single-axis controller with a nominal output current of up to 32 A and 250% overload capacity
- Control of rotary synchronous servo motors and asynchronous motors
- Control of linear and torque motors
- Sensorless position control of STOBER Lean motors
- One Cable Solution EnDat 3
- Electronic motor nameplate via EnDat encoder interfaces
- Integrated EtherCAT or PROFINET communication
- STO safety technology using terminals or STO and SS1 using FSoE or PROFIsafe: SIL 3, PL e (Cat. 4)
- Extended safety technology (SS1, SS2, SLS, SBC, SBT...) using FSoE
- Optional operating unit consisting of text display and keys
- Modular interface concept
- Integrated brake control
- Energy supply through direct power feed-in
- Available EPLAN macros in the EPLAN Data Portal

## 2.1.1 Features

With its modular interface concept and compact design, the stand-alone SB6 drive controller enables extremely versatile system designs. SB6 is available as a single-axis controller in three sizes with a nominal output current of up to 32 A. If you are looking for a universal and flexible solution, the SB6 drive controller is the right choice.



*SB6 drive controllers*

### Easy connection, quick and safe parameterization

The One Cable Solution (OCS) from STOBBER combines power and encoder communication in a single hybrid cable – for minimal cabling and easy installation.

The electronic motor nameplate is automatically transmitted via the digital EnDat 3 interface. The drive controller detects all the motor data automatically – the parameterization process is fast, reliable and error-free.

The optimized hybrid cable offers maximum signal quality and system reliability.

Ready-to-connect power and encoder cables with an EnDat 2.2 interface and electronic nameplate function are available as alternatives. Both variants ensure optimal coordination of the interaction between the motor and drive controller – for efficient and reliable commissioning.

### Play it safe with STOBBER

#### Integrated safety

STOBBER drive controllers have safety functions such as Safe Torque Off (STO) and Safe Stop 1 (SS1) that can be controlled either conventionally via terminals, or via the safe communication standards PROFIsafe (PROFINET) and Fail Safe over EtherCAT (FSoE). The fully electronic design works quickly and free of wear. Additional cyclical function tests are no longer necessary. This increases availability and reduces the amount of testing required during operation.

#### Extended safety

For stricter requirements, STOBBER offers optional safety functions up to SIL 3, PL e (category 4). These include functions such as Safely Limited Speed (SLS) for safe speed monitoring and Safe Operating Stop (SOS) to safely keep stopped axes in place, as well as Safe Brake Control (SBC) and Safe Brake Test (SBT) for reliable brake control and testing. Optimized monitoring mechanisms ensure short reaction times, minimum safety distances and increased system availability – for productive safety at the highest level.

#### Robust and resilient

The drive controllers boast a stable, durable design. The housing is made from high-quality sheet steel for reliable shielding, mechanical strength and optimum heat dissipation – even under demanding operating conditions. Inside, powerful computing units, carefully selected components and precision manufacturing ensure reliable operation over the long term.

An SD card slot is available on the front panel for removable data storage. An SD card can be used for quick series commissioning by copying, or for easy device replacement in the event of servicing. The removable data storage can also be used as a medium for storing additional project data and documentation.

## 2.1.2 Software components

### Project configuration and commissioning

The DriveControlSuite project configuration and commissioning software has all the functions for the efficient use of drive controllers in single-axis and multi-axis applications. The program guides you step by step through the complete project configuration and parameterization process using wizards.

### Open communication

The Ethernet-based EtherCAT and PROFINET fieldbus systems are available in the drive controller.

### Applications

A drive-based application is recommended for the decentralized motion control of sophisticated machines.

The drive-based application package from STOBBER is the right choice wherever universal and flexible solutions are needed. The Drive Based application provides drive-based motion control for positioning, velocity and torque/force with the PLCopen Motion Control command set. These standard commands have been combined into operating modes for different applications and supplemented with additional functions such as motion block linking, cams and much more. For the command operating mode, all properties of the movements are specified directly by the controller. The properties of the movements in the drive are predefined in the motion block operating mode so that only a start signal is necessary to perform the movement. Linking can be used to define complete motion sequences. There is a separate operating mode available for applications controlled by velocity or torque/force such as pumps, fans or conveyor belts. This also allows for operation without a controller.

In addition, the CiA 402 and PROFIdrive applications are also available, which include both the controller-based and drive-based operating modes and application classes. For example, standard telegrams 1, 2 and 3 as well as telegrams 102 and 111 are available for standard drives according to PROFIdrive in application class 1 and for decentralized positioning control according to application class 3. Based on these telegrams, the drive controllers can be used with the SpeedAxis and BasicPos (EPos) technology objects.

Standard telegrams 3 and 5 as well as telegram 105 are available for controller-based motion control according to PROFIdrive in application class 4.

Furthermore, programming based on IEC 61131-3 with CFC can be used to create new applications or expand existing ones.

## 2.1.3 Operating motors, encoders and brakes

You can use the drive controller to operate Lean motors of the LM series, synchronous servo motors (such as those of the EZ series), asynchronous motors, linear motors or torque motors.

Evaluation options for feedback are available on the X4 connection for the following encoders:

- EnDat 2.1/2.2 digital encoders
- SSI encoders
- Differential TTL and differential HTL incremental encoders
- EnDat 3 or HIPERFACE DSL encoders (with One Cable Solution design)

In addition, evaluation options for the following encoders are available on the X1 connection:

- Single-ended HTL incremental encoders
- Single-ended HTL pulse/direction interface

The following additional encoder types can be connected via the optional available XB6 terminal module:

- Resolvers
- EnDat 2.1 sin/cos encoders
- Sin/cos encoders
- EnDat 2.1/2.2 digital encoders
- SSI encoders
- Differential TTL incremental encoders
- Differential TTL pulse/direction interface
- Differential TTL Hall sensor

All device types of the drive controller have connections for PTC thermistors and can activate a 24 V<sub>DC</sub> brake as standard.

## 2.1.4 Application training

STOBER offers a multi-level training program that is essentially focused on the drive controller.

### G6 Basic

Training content: System overview, installation and commissioning of the drive controller. Use of option modules. Parameterization, commissioning and diagnostics using the commissioning software. Remote maintenance. Basics of controller optimization. Configuration of the drive train. Integrated software functions. Software applications. Connection to a higher-level controller. Basics of safety technology. Practical exercises on training topics.

Software used: DriveControlSuite.

### G6 Customized

Training content: Special knowledge for regulating, control and safety technology. Practical exercises on training topics.

## 2.2 Technical data

Technical data for the drive controller can be found in the following chapters.

### 2.2.1 Type designation

SB	6	A	0	6	Z	X	O
----	---	---	---	---	---	---	---

Tab. 1: Example code for type designation

Code	Designation	Design
SB	Series	
6	Generation	Generation 6
A	Version	
0 – 2	Size	
6	Power output stage	Power output stage within the size
Z	Safety technology	SZ6: Without safety technology
R		SR6: STO using terminals
U		SU6: STO and SS1 using PROFIsafe
Y		SY6: STO and SS1 using FSoE
X		SX6: Extended safety technology using FSoE
N	Terminal module	Without terminal module
X		XB6: With extended terminal option
N	Operating unit	Without operating unit
O		OP6: With operating unit

Tab. 2: Meaning of the example code

### 2.2.2 Sizes

Type	ID No.	Size	Axis controller
SB6A06	5050162	Size 0	Single-axis controller
SB6A16	5050164	Size 1	Single-axis controller
SB6A26	5050166	Size 2	Single-axis controller

Tab. 3: Available SB6 types and sizes



SB6 in sizes 2, 1 and 0

Note that the basic device is delivered without terminals. Suitable terminal sets can be ordered with the drive controllers or as separate accessories.

## 2.2.3 General technical data

The following information applies to all device types.

Device features	
Protection class of the device	IP20
Protection class of the installation space	At least IP54
Protection class	Protection class I in accordance with EN 61140
Radio interference suppression	Integrated line filter in accordance with EN 61800-3, interference emission class C3
Overvoltage category	III in accordance with EN 61800-5-1
Marks and test symbols	CE, cULus, RoHS

Tab. 4: Device features

Transport and storage conditions	
Storage/transport temperature	-20 °C to +70 °C Maximum change: 20 K/h
Relative humidity	Maximum relative humidity 85%, non-condensing
Vibration (transport) in accordance with EN 60068-2-6	5 Hz ≤ f ≤ 9 Hz: 3.5 mm 9 Hz ≤ f ≤ 200 Hz: 10 m/s <sup>2</sup> 200 Hz ≤ f ≤ 500 Hz: 15 m/s <sup>2</sup>
Fall height for free fall <sup>1</sup> Weight < 100 kg in accordance with EN 61800-2 (or IEC 60721-3-2, class 2M4)	0.25 m
Shock testing in accordance with EN 60068-2-27	Pulse shape: Half-sine Acceleration: 5 g Shock duration: 30 ms Number of shocks: 3 per axis

Tab. 5: Transport and storage conditions

Operating conditions	
Surrounding temperature during operation	0 °C to 45 °C with nominal data 45 °C to 55 °C with derating -2.5% / K
Relative humidity	Maximum relative humidity 85%, non-condensing
Installation altitude	0 m to 1000 m above sea level without restrictions 1000 m to 2000 m above sea level with -1.5%/100 m derating
Pollution degree	Pollution degree 2 in accordance with EN 50178
Ventilation	Installed fan
Vibration (operation) in accordance with EN 60068-2-6	5 Hz ≤ f ≤ 9 Hz: 0.35 mm 9 Hz ≤ f ≤ 200 Hz: 1 m/s <sup>2</sup>

Tab. 6: Operating conditions

Discharge times	
Self-discharge of DC link	15 min

Tab. 7: Discharge times of the DC link circuit

<sup>1</sup>Only valid for components in their original packaging.

## 2.2.4 Electrical data

The electrical data of the available sizes as well as the properties of the brake chopper can be found in the following chapters.

An explanation of the symbols used for formulas can be found in Chapter [\[ 9.1 \]](#).

### 2.2.4.1 Control unit

Electrical data	All types
$U_{1CU}$	24 V <sub>DC</sub> , +20%/–15%
$I_{1maxCU}$	1.5 A

Tab. 8: Control unit electrical data

### 2.2.4.2 Power unit: Size 0

Electrical data	SB6A06
$U_{1PU}$	3 × 400 V <sub>AC</sub> , +32% / –50%, 50/60 Hz; 3 × 480 V <sub>AC</sub> , +10% / –58%, 50/60 Hz
$f_{2PU}$	0 – 700 Hz
$U_{2PU}$	0 – max. $U_{1PU}$
$U_{2PU,ZK}$	$\sqrt{2} \times U_{1PU}$
$C_{PU}$	135 μF
$C_{N,PU}$	540 μF

Tab. 9: SB6 electrical data, size 0

#### Nominal currents up to +45 °C (in the control cabinet)

Electrical data	SB6A06
$f_{PWM,PU}$	4 kHz
$I_{1N,PU}$	5.4 A
$I_{2N,PU}$	4.5 A
$I_{2maxPU}$	180% for 5 s; 150% for 30 s

Tab. 10: SB6 electrical data, size 0, for 4 kHz clock frequency

Electrical data	SB6A06
$f_{PWM,PU}$	8 kHz
$I_{1N,PU}$	4 A
$I_{2N,PU}$	3.8 A
$I_{2maxPU}$	250% for 2 s; 200% for 5 s

Tab. 11: SB6 electrical data, size 0, for 8 kHz clock frequency

Electrical data	SB6A06
$U_{onCH}$	780 – 800 V <sub>DC</sub>
$U_{offCH}$	740 – 760 V <sub>DC</sub>
$R_{2minRB}$	100 Ω
$P_{maxRB}$	6.4 kW
$P_{effRB}$	2.9 kW

Tab. 12: Brake chopper electrical data, size 0

### 2.2.4.3 Power unit: Size 1

Electrical data	SB6A16
$U_{1PU}$	$3 \times 400 V_{AC}$ , +32% / -50%, 50/60 Hz; $3 \times 480 V_{AC}$ , +10% / -58%, 50/60 Hz
$f_{2PU}$	0 – 700 Hz
$U_{2PU}$	0 – max. $U_{1PU}$
$U_{2PU,ZK}$	$\sqrt{2} \times U_{1PU}$
$C_{PU}$	560 $\mu$ F
$C_{N,PU}$	1400 $\mu$ F

Tab. 13: SB6 electrical data, size 1

#### Nominal currents up to +45 °C (in the control cabinet)

Electrical data	SB6A16
$f_{PWM,PU}$	4 kHz
$I_{1N,PU}$	19.2 A
$I_{2N,PU}$	16 A
$I_{2maxPU}$	180% for 5 s; 150% for 30 s

Tab. 14: SB6 electrical data, size 1, for 4 kHz clock frequency

Electrical data	SB6A16
$f_{PWM,PU}$	8 kHz
$I_{1N,PU}$	15.8 A
$I_{2N,PU}$	12 A
$I_{2maxPU}$	250% for 2 s; 200% for 5 s

Tab. 15: SB6 electrical data, size 1, for 8 kHz clock frequency

Electrical data	SB6A16
$U_{onCH}$	780 – 800 $V_{DC}$
$U_{offCH}$	740 – 760 $V_{DC}$
$R_{2minRB}$	47 $\Omega$
$P_{maxRB}$	13.6 kW
$P_{effRB}$	6.2 kW

Tab. 16: Brake chopper electrical data, size 1

## 2.2.4.4 Power unit: Size 2

Electrical data	SB6A26
$U_{1PU}$	$3 \times 400 V_{AC}$ , +32% / -50%, 50/60 Hz; $3 \times 480 V_{AC}$ , +10% / -58%, 50/60 Hz
$f_{2PU}$	0 – 700 Hz
$U_{2PU}$	0 – max. $U_{1PU}$
$U_{2PU,ZK}$	$\sqrt{2} \times U_{1PU}$
$C_{PU}$	1000 $\mu$ F
$C_{N,PU}$	1400 $\mu$ F

Tab. 17: SB6 electrical data, size 2

## Nominal currents up to +45 °C (in the control cabinet)

Electrical data	SB6A26
$f_{PWM,PU}$	4 kHz
$I_{1N,PU}$	38.4 A
$I_{2N,PU}$	32 A
$I_{2maxPU}$	180% for 5 s; 150% for 30 s

Tab. 18: SB6 electrical data, size 2, for 4 kHz clock frequency

Electrical data	SB6A26
$f_{PWM,PU}$	8 kHz
$I_{1N,PU}$	32.6 A
$I_{2N,PU}$	20 A
$I_{2maxPU}$	250% for 2 s; 200% for 5 s

Tab. 19: SB6 electrical data, size 2, for 8 kHz clock frequency

Electrical data	SB6A26
$U_{onCH}$	780 – 800 $V_{DC}$
$U_{offCH}$	740 – 760 $V_{DC}$
$R_{2minRB}$	22 $\Omega$
$P_{maxRB}$	29.1 kW
$P_{effRB}$	13.2 kW

Tab. 20: Brake chopper electrical data, size 2

### 2.2.4.5 DC link connection

The charging capacity of the drive controllers can be increased by a DC link connection only if the power supply is connected to all drive controllers simultaneously.

### 2.2.4.6 Power loss data in accordance with EN 61800-9-2

Type	Nominal current $I_{2N,PU}$	Apparent power	Absolute losses $P_{V,CU}^2$	Operating points <sup>3</sup>								IE class <sup>4</sup>	Comparison <sup>5</sup>
				(0/25)	(0/50)	(0/100)	(50/25)	(50/50)	(50/100)	(90/50)	(90/100)		
				Relative losses									
				[A]									
				[kVA]									
				[W]									
				[%]									
SB6A06	4.5	3.1	Max. 12	1.71	1.86	2.24	1.75	1.97	2.51	2.16	3.04	IE2	
SB6A16	16	11.1	Max. 12	0.95	1.12	1.66	0.99	1.23	1.98	1.41	2.52	IE2	
SB6A26	32	22.2	15	0.70	0.87	1.40	0.74	0.97	1.67	1.11	2.10	IE2	
				Absolute losses									
				$P_V$									
				[A]									
				[kVA]									
				[W]									
				[W]								[%]	
SB6A06	4.5	3.1	Max. 12	52.9	57.6	69.3	54.4	61.0	77.9	67.1	94.1	IE2	39.6
SB6A16	16	11.1	Max. 12	104.9	124.0	184.6	110.3	136.6	219.8	156.0	279.8	IE2	35.8
SB6A26	32	22.2	Max. 15	154.7	192.8	311.3	164.7	214.9	370.5	246.9	465.9	IE2	38.6

Tab. 21: Power loss data of the SB6 drive controller in accordance with EN 61800-9-2

#### General conditions

The power loss data applies to drive controllers without accessories.

The power loss calculation is based on a 3-phase supply voltage with 400 V<sub>AC</sub>/50 Hz.

The calculated data includes a supplement of 10% in accordance with EN 61800-9-2.

The power loss specifications refer to a clock frequency of 4 kHz.

The absolute losses for a power unit that is switched off refer to the 24 V<sub>DC</sub> power supply of the control electronics.

### 2.2.4.7 Power loss data of accessories

If you intend to order the drive controller with accessory parts, losses increase as follows.

Type	Absolute losses $P_V$ [W]
SR6 safety module	1
SY6 or SU6 safety module	2
SX6 safety module	< 4
XB6 terminal module	< 5
OP6 operating unit	1

Tab. 22: Absolute losses of the accessories

#### Information

Note the absolute power loss of the encoder (usually < 3 W) and of the brake when designing as well.

Loss specifications for other optional accessories can be found in the technical data of the respective accessory part.

<sup>2</sup> Absolute losses for a power unit that is switched off

<sup>3</sup> Operating points for relative motor stator frequency in % and relative torque current in %

<sup>4</sup> IE class in accordance with EN 61800-9-2

<sup>5</sup> Comparison of the losses for the reference related to IE2 in the nominal point (90, 100)

## 2.2.5 Cycle times

Possible cycle times can be found in the following table.

Type	Cycle times	Relevant parameters
Application	250 $\mu$ s, 500 $\mu$ s, 1 ms, 2 ms, 4 ms, 8 ms	Adjustable in A150
EtherCAT fieldbus, cyclical communication	250 $\mu$ s, 500 $\mu$ s, 1 ms, 2 ms, 4 ms, 8 ms	Adjustable in TwinCAT 3 or CODESYS
PROFINET RT fieldbus, cyclical communication	1 ms, 2 ms, 4 ms, 8 ms	Adjustable in the TIA Portal
PROFINET IRT fieldbus, cyclical communication	1 ms, 2 ms, 4 ms	Adjustable in the TIA Portal
Motion core (movement calculation)	250 $\mu$ s	—
Control cascade	62.5 $\mu$ s	B24 $\geq$ 8 kHz and B20 = 48, 64 or 70
	125 $\mu$ s	B24 = 4 kHz

Tab. 23: Cycle times

### Information

For Lean motors (control mode B20 = 32: LM - sensorless vector control), only operation at 4 kHz is permitted.

## 2.2.6 Derating

When dimensioning the drive controller, observe the derating of the nominal output current as a function of the clock frequency, surrounding temperature and installation altitude. There is no restriction for a surrounding temperature from 0 °C to 45 °C and an installation altitude of 0 m to 1000 m. The details given below apply to values outside these ranges.

### 2.2.6.1 Effect of the clock frequency

Changing the clock frequency  $f_{\text{PWM}}$  affects the amount of noise produced by the drive, among other things. However, increasing the clock frequency results in increased losses. During project configuration, define the highest clock frequency and use it to determine the nominal output current  $I_{2N,PU}$  for dimensioning the drive controller.

Type	$I_{2N,PU}$ 4 kHz [A]	$I_{2N,PU}$ 8 kHz [A]	$I_{2N,PU}$ 16 kHz [A]
SB6A06	4.5	3.8	2.3
SB6A16	16	12	5.7
SB6A26	32	20	12

Tab. 24: Nominal output current  $I_{2N,PU}$  dependent on the clock frequency

### 2.2.6.2 Effect of the installation altitude

Derating as a function of the installation altitude is determined as follows:

- 0 m to 1000 m: No restriction ( $D_{IA} = 100\%$ )
- 1000 m to 2000 m: Derating  $-1.5\%/100$  m

#### Example

The drive controller needs to be installed at an altitude of 1500 m above sea level.

The derating factor  $D_{IA}$  is calculated as follows:

$$D_{IA} = 100\% - 5 \times 1.5\% = 92.5\%$$

### 2.2.6.3 Effect of the surrounding temperature

Derating as a function of the surrounding temperature is determined as follows:

- 0 °C to 45 °C: No restrictions ( $D_T = 100\%$ )
- 45 °C to 55 °C: Derating  $-2.5\%/K$

#### Example

The drive controller needs to be operated at 50 °C.

The derating factor  $D_T$  is calculated as follows

$$D_T = 100\% - 5 \times 2.5\% = 87.5\%$$

### 2.2.6.4 Calculating the derating

Follow these steps for the calculation:

1. Determine the highest clock frequency ( $f_{PWM}$ ) that will be used during operation and use it to determine the nominal current  $I_{2N,PU}$ .
2. Determine the derating factors for installation altitude and surrounding temperature.
3. Calculate the reduced nominal current  $I_{2N,PU(red)}$  in accordance with the following formula:

$$I_{2N,PU(red)} = I_{2N,PU} \times D_T \times D_{IA}$$

#### Example

A drive controller of type SB6A06 needs to be operated at a clock frequency of 8 kHz at an altitude of 1500 m above sea level and a surrounding temperature of 50 °C.

The nominal current of the SB6A06 at 8 kHz is 3.8 A. The derating factor  $D_T$  is calculated as follows:

$$D_T = 100\% - 5 \times 2.5\% = 87.5\%$$

The derating factor  $D_{IA}$  is calculated as follows:

$$D_{IA} = 100\% - 5 \times 1.5\% = 92.5\%$$

The output current of importance for the project configuration is:

$$I_{2N,PU(red)} = 3.8 \text{ A} \times 0.875 \times 0.925 = 2.75 \text{ A}$$

## 2.2.7 Dimensions

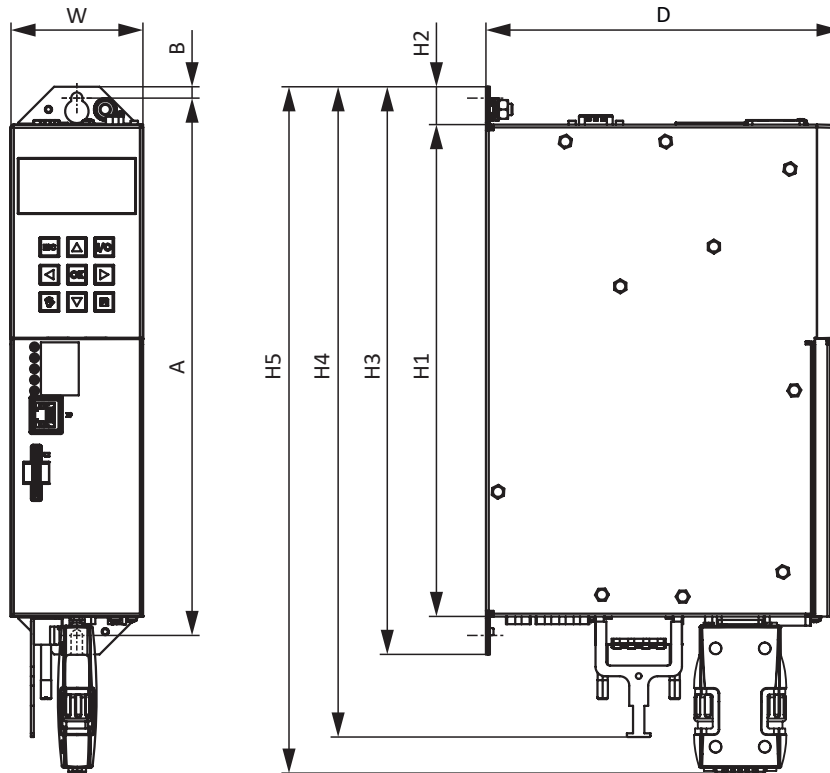

Fig. 1: SB6 dimensional drawing

Dimension			SB6A06	SB6A16	SB6A26
Drive controller	Width	W	70		105
	Depth	D	188	276	
	Body height	H1	260		
	Fastening clip height	H2	20		
	Height incl. fastening clips	H3	300		
	Total height incl. shield contact (terminal X20)	H4	344	362	
	Height incl. AES	H5	360		
	Fastening bores (M5)	Vertical distance	A	283+2	
Vertical distance to the upper edge		B	6		

Tab. 25: SB6 dimensions [mm]

If you are using shield plate EM6 instead of a shield contact at terminal X20, please note the following deviating total height H4:

Dimension			SB6A06	SB6A16	SB6A26
Drive controller	Total height incl. shield plate EM6	H4	360		

Tab. 26: Total height including shield plate EM6 [mm]

Take the additional installation depth of the rear section modules into account when calculating the overall dimensions.

## 2.2.8 Weight

Type	Weight without packaging [g]	Weight with packaging [g]
SB6A06	2500	3500
SB6A16	3700	5400
SB6A26	5000	6500

Tab. 27: SB6 weight [g]

## 2.2.9 Minimum clearances

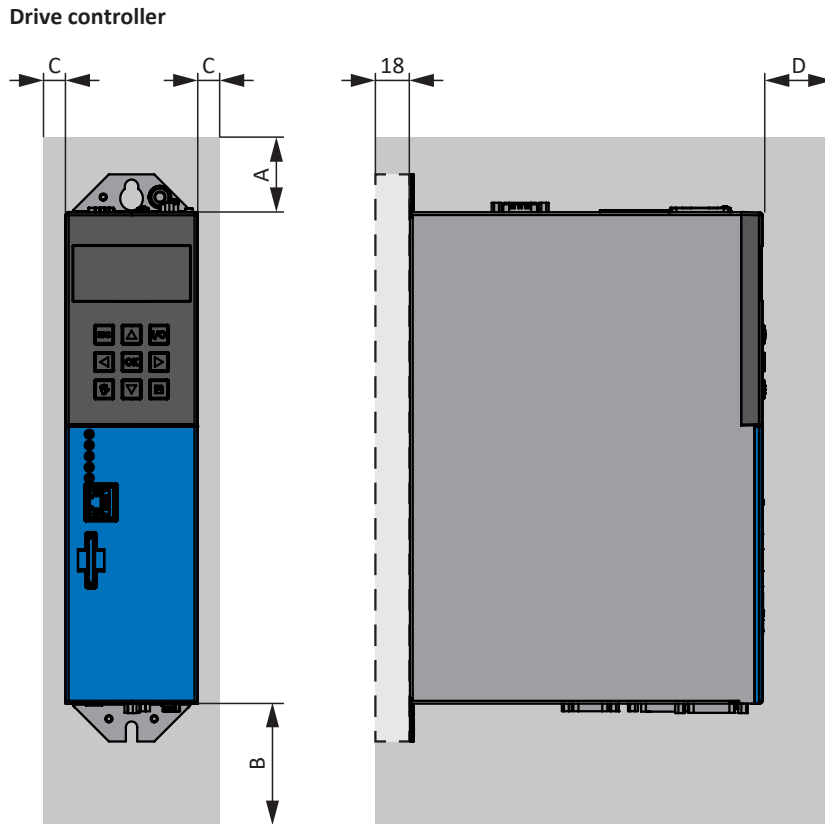

Fig. 2: Minimum clearances

Take into account the additional installation depth of 18 mm for the optional RB 5000 rear section braking resistor.

The dimensions specified in the table relate to the outer edges of the drive controller.

Minimum clearance	A (above)	B (below)	C (on the side)	D (in front)
All sizes	100	200	5	50 <sup>6</sup>

Tab. 28: Minimum clearances [mm]

### Chokes and filters

Avoid installation below drive controllers or supply modules. For installation in a control cabinet, a distance of approximately 100 mm to other neighboring components is recommended. This distance ensures proper heat dissipation for chokes and filters.

### Braking resistors

Avoid installation below drive controllers or supply modules. In order for heated air to flow out unimpeded, a minimum clearance of approximately 200 mm must be maintained in relation to neighboring components or walls and approximately 300 mm must be maintained to components above or ceilings.

<sup>6</sup> Minimum clearance to be taken into account for permanent connection of the X9 service interface

## 2.3 Drive controller/motor combinations

An explanation of the symbols used for formulas can be found in Chapter [9.1](#).

### IC 410 convection cooling

Type	$K_{EM}$ [V/1000 min <sup>-1</sup> ]	$n_N$ [rpm]	$M_N$ [Nm]	$I_N$ [A]	$M_0$ [Nm]	$I_0$ [A]	Type	$f_{PWM,PU}$ [kHz]	$I_{2N,PU}$ [A]	$I_{2N,PU}/I_0$
<b>EZ2</b>										
EZ203U	40	6000	0.61	1.54	0.69	1.64	SB6A06	4	4.5	2.7
EZ203U	40	6000	0.61	1.54	0.69	1.64	SB6A06	8	3.8	2.3
<b>EZ3</b>										
EZ301U	40	3000	0.93	1.99	0.95	2.02	SB6A06	4	4.5	2.2
EZ301U	40	3000	0.93	1.99	0.95	2.02	SB6A06	8	3.8	1.9
EZ301U	40	6000	0.89	1.93	0.95	2.02	SB6A06	4	4.5	2.2
EZ301U	40	6000	0.89	1.93	0.95	2.02	SB6A06	8	3.8	1.9
EZ302U	86	3000	1.59	1.60	1.68	1.67	SB6A06	4	4.5	2.7
EZ302U	86	3000	1.59	1.60	1.68	1.67	SB6A06	8	3.8	2.3
EZ302U	42	6000	1.50	3.18	1.68	3.48	SB6A06	4	4.5	1.3
EZ302U	42	6000	1.50	3.18	1.68	3.48	SB6A06	8	3.8	1.1
EZ303U	109	3000	2.07	1.63	2.19	1.71	SB6A06	4	4.5	2.6
EZ303U	109	3000	2.07	1.63	2.19	1.71	SB6A06	8	3.8	2.2
EZ303U	55	6000	1.96	3.17	2.25	3.55	SB6A06	4	4.5	1.3
EZ303U	55	6000	1.96	3.17	2.25	3.55	SB6A06	8	3.8	1.1
<b>EZ4</b>										
EZ401U	96	3000	2.80	2.74	3.00	2.88	SB6A06	4	4.5	1.6
EZ401U	96	3000	2.80	2.74	3.00	2.88	SB6A06	8	3.8	1.3
EZ401U	47	6000	2.30	4.56	2.80	5.36	SB6A16	4	16	3.0
EZ401U	47	6000	2.30	4.56	2.80	5.36	SB6A16	8	12	2.2
EZ402U	94	3000	4.70	4.40	5.20	4.80	SB6A16	8	12	2.5
EZ402U	60	6000	3.50	5.65	4.90	7.43	SB6A16	4	16	2.2
EZ402U	60	6000	3.50	5.65	4.90	7.43	SB6A16	8	12	1.6
EZ402U	60	6000	3.50	5.65	4.90	7.43	SB6A26	8	20	2.7
EZ404U	116	3000	6.90	5.80	8.60	6.60	SB6A16	4	16	2.4
EZ404U	116	3000	6.90	5.80	8.60	6.60	SB6A16	8	12	1.8
EZ404U	78	6000	5.80	7.18	8.40	9.78	SB6A16	4	16	1.6
EZ404U	78	6000	5.80	7.18	8.40	9.78	SB6A16	8	12	1.2
EZ404U	78	6000	5.80	7.18	8.40	9.78	SB6A26	8	20	2.0
<b>EZ5</b>										
EZ501U	97	3000	4.30	3.74	4.70	4.00	SB6A06	4	4.5	1.1
EZ501U	97	3000	4.30	3.74	4.70	4.00	SB6A16	8	12	3.0
EZ501U	68	6000	3.40	4.77	4.40	5.80	SB6A16	4	16	2.8
EZ501U	68	6000	3.40	4.77	4.40	5.80	SB6A16	8	12	2.1
EZ502U	121	3000	7.40	5.46	8.00	5.76	SB6A16	4	16	2.8
EZ502U	121	3000	7.40	5.46	8.00	5.76	SB6A16	8	12	2.1
EZ502U	72	6000	5.20	7.35	7.80	9.80	SB6A16	4	16	1.6
EZ502U	72	6000	5.20	7.35	7.80	9.80	SB6A16	8	12	1.2
EZ502U	72	6000	5.20	7.35	7.80	9.80	SB6A26	8	20	2.0
EZ503U	119	3000	9.70	6.90	11.1	7.67	SB6A16	4	16	2.1
EZ503U	119	3000	9.70	6.90	11.1	7.67	SB6A16	8	12	1.6
EZ503U	119	3000	9.70	6.90	11.1	7.67	SB6A26	8	20	2.6
EZ503U	84	6000	6.20	7.64	10.6	11.6	SB6A16	4	16	1.4
EZ503U	84	6000	6.20	7.64	10.6	11.6	SB6A16	8	12	1.0
EZ503U	84	6000	6.20	7.64	10.6	11.6	SB6A26	4	32	2.8
EZ503U	84	6000	6.20	7.64	10.6	11.6	SB6A26	8	20	1.7
EZ505U	141	3000	13.5	8.80	16.0	10.0	SB6A16	4	16	1.6
EZ505U	141	3000	13.5	8.80	16.0	10.0	SB6A16	8	12	1.2
EZ505U	141	3000	13.5	8.80	16.0	10.0	SB6A26	8	20	2.0
EZ505U	103	4500	9.50	8.94	15.3	13.4	SB6A16	4	16	1.2
EZ505U	103	4500	9.50	8.94	15.3	13.4	SB6A26	4	32	2.4
EZ505U	103	4500	9.50	8.94	15.3	13.4	SB6A26	8	20	1.5
<b>EZ7</b>										
EZ701U	95	3000	7.40	7.20	8.30	8.00	SB6A16	4	16	2.0
EZ701U	95	3000	7.40	7.20	8.30	8.00	SB6A16	8	12	1.5
EZ701U	95	3000	7.40	7.20	8.30	8.00	SB6A26	8	20	2.5
EZ701U	76	6000	5.20	6.68	7.90	9.38	SB6A16	4	16	1.7
EZ701U	76	6000	5.20	6.68	7.90	9.38	SB6A16	8	12	1.3
EZ701U	76	6000	5.20	6.68	7.90	9.38	SB6A26	8	20	2.1

Type	$K_{EM}$ [V/1000 min <sup>-1</sup> ]	$n_N$ [rpm]	$M_N$ [Nm]	$I_N$ [A]	$M_0$ [Nm]	$I_0$ [A]	Type	$f_{PWM,PU}$ [kHz]	$I_{2N,PU}$ [A]	$I_{2N,PU}/I_0$
<b>EZ7</b>										
EZ702U	133	3000	12.0	8.20	14.4	9.60	SB6A16	4	16	1.7
EZ702U	133	3000	12.0	8.20	14.4	9.60	SB6A16	8	12	1.3
EZ702U	133	3000	12.0	8.20	14.4	9.60	SB6A26	8	20	2.1
EZ702U	82	6000	7.20	8.96	14.3	16.5	SB6A26	4	32	1.9
EZ702U	82	6000	7.20	8.96	14.3	16.5	SB6A26	8	20	1.2
EZ703U	122	3000	16.5	11.4	20.8	14.0	SB6A16	4	16	1.1
EZ703U	122	3000	16.5	11.4	20.8	14.0	SB6A26	4	32	2.3
EZ703U	122	3000	16.5	11.4	20.8	14.0	SB6A26	8	20	1.4
EZ703U	99	4500	12.1	11.5	20.0	17.8	SB6A26	4	32	1.8
EZ703U	99	4500	12.1	11.5	20.0	17.8	SB6A26	8	20	1.1
EZ705U	140	3000	21.3	14.2	30.2	19.5	SB6A26	4	32	1.6
EZ705U	140	3000	21.3	14.2	30.2	19.5	SB6A26	8	20	1.0
EZ705U	106	4500	16.4	14.8	30.0	25.2	SB6A26	4	32	1.3
<b>EZ8</b>										
EZ813U	239	2000	39.0	14.9	43.7	16.5	SB6A26	4	32	1.9
EZ813U	239	2000	39.0	14.9	43.7	16.5	SB6A26	8	20	1.2
EZ815U	239	2000	57.8	21.5	68.8	25.2	SB6A26	4	32	1.3

## IC 416 forced ventilation

Type	$K_{EM}$ [V/1000 min <sup>-1</sup> ]	$n_N$ [rpm]	$M_N$ [Nm]	$I_N$ [A]	$M_0$ [Nm]	$I_0$ [A]	Type	$f_{PWM,PU}$ [kHz]	$I_{2N,PU}$ [A]	$I_{2N,PU}/I_0$
<b>EZ4</b>										
EZ401B	96	3000	3.40	3.40	3.70	3.60	SB6A06	4	4.5	1.3
EZ401B	96	3000	3.40	3.40	3.70	3.60	SB6A06	8	3.8	1.1
EZ401B	47	6000	2.90	5.62	3.50	6.83	SB6A16	4	16	2.3
EZ401B	47	6000	2.90	5.62	3.50	6.83	SB6A16	8	12	1.8
EZ401B	47	6000	2.90	5.62	3.50	6.83	SB6A26	8	20	2.9
EZ402B	94	3000	5.90	5.50	6.30	5.80	SB6A16	4	16	2.8
EZ402B	94	3000	5.90	5.50	6.30	5.80	SB6A16	8	12	2.1
EZ402B	60	6000	5.10	7.88	6.40	9.34	SB6A16	4	16	1.7
EZ402B	60	6000	5.10	7.88	6.40	9.34	SB6A16	8	12	1.3
EZ402B	60	6000	5.10	7.88	6.40	9.34	SB6A26	8	20	2.1
EZ404B	116	3000	10.2	8.20	11.2	8.70	SB6A16	4	16	1.8
EZ404B	116	3000	10.2	8.20	11.2	8.70	SB6A16	8	12	1.4
EZ404B	116	3000	10.2	8.20	11.2	8.70	SB6A26	8	20	2.3
EZ404B	78	6000	8.00	9.98	10.5	12.0	SB6A16	4	16	1.3
EZ404B	78	6000	8.00	9.98	10.5	12.0	SB6A16	8	12	1.0
EZ404B	78	6000	8.00	9.98	10.5	12.0	SB6A26	4	32	2.7
EZ404B	78	6000	8.00	9.98	10.5	12.0	SB6A26	8	20	1.7
<b>EZ5</b>										
EZ501B	97	3000	5.40	4.70	5.80	5.00	SB6A16	8	12	2.4
EZ501B	68	6000	4.50	6.70	5.70	7.50	SB6A16	4	16	2.1
EZ501B	68	6000	4.50	6.70	5.70	7.50	SB6A16	8	12	1.6
EZ501B	68	6000	4.50	6.70	5.70	7.50	SB6A26	8	20	2.7
EZ502B	121	3000	10.3	7.80	11.2	8.16	SB6A16	4	16	2.0
EZ502B	121	3000	10.3	7.80	11.2	8.16	SB6A16	8	12	1.5
EZ502B	121	3000	10.3	7.80	11.2	8.16	SB6A26	8	20	2.5
EZ502B	72	6000	8.20	11.4	10.5	13.4	SB6A16	4	16	1.2
EZ502B	72	6000	8.20	11.4	10.5	13.4	SB6A26	4	32	2.4
EZ502B	72	6000	8.20	11.4	10.5	13.4	SB6A26	8	20	1.5
EZ503B	119	3000	14.4	10.9	15.9	11.8	SB6A16	4	16	1.4
EZ503B	119	3000	14.4	10.9	15.9	11.8	SB6A16	8	12	1.0
EZ503B	119	3000	14.4	10.9	15.9	11.8	SB6A26	4	32	2.7
EZ503B	119	3000	14.4	10.9	15.9	11.8	SB6A26	8	20	1.7
EZ503B	84	6000	10.4	13.5	14.8	15.9	SB6A16	4	16	1.0
EZ503B	84	6000	10.4	13.5	14.8	15.9	SB6A26	4	32	2.0
EZ503B	84	6000	10.4	13.5	14.8	15.9	SB6A26	8	20	1.3
EZ505B	141	3000	20.2	13.7	23.4	14.7	SB6A16	4	16	1.1
EZ505B	141	3000	20.2	13.7	23.4	14.7	SB6A26	4	32	2.2
EZ505B	141	3000	20.2	13.7	23.4	14.7	SB6A26	8	20	1.4
EZ505B	103	4500	16.4	16.4	22.0	19.4	SB6A26	4	32	1.7
EZ505B	103	4500	16.4	16.4	22.0	19.4	SB6A26	8	20	1.0
<b>EZ7</b>										
EZ701B	95	3000	9.70	9.50	10.5	10.0	SB6A16	4	16	1.6
EZ701B	95	3000	9.70	9.50	10.5	10.0	SB6A16	8	12	1.2
EZ701B	95	3000	9.70	9.50	10.5	10.0	SB6A26	8	20	2.0
EZ701B	76	6000	7.50	10.6	10.2	12.4	SB6A16	4	16	1.3
EZ701B	76	6000	7.50	10.6	10.2	12.4	SB6A26	4	32	2.6
EZ701B	76	6000	7.50	10.6	10.2	12.4	SB6A26	8	20	1.6
EZ702B	133	3000	16.6	11.8	19.3	12.9	SB6A16	4	16	1.2
EZ702B	133	3000	16.6	11.8	19.3	12.9	SB6A26	4	32	2.5
EZ702B	133	3000	16.6	11.8	19.3	12.9	SB6A26	8	20	1.6
EZ702B	82	6000	12.5	16.7	19.3	22.1	SB6A26	4	32	1.5
EZ703B	122	3000	24.0	18.2	28.0	20.0	SB6A26	4	32	1.6
EZ703B	122	3000	24.0	18.2	28.0	20.0	SB6A26	8	20	1.0
EZ703B	99	4500	19.8	20.3	27.2	24.2	SB6A26	4	32	1.3
EZ705B	140	3000	33.8	22.9	41.8	26.5	SB6A26	4	32	1.2
<b>EZ8</b>										
EZ813B	239	2000	57.3	21.9	61.6	22.9	SB6A26	4	32	1.4

## 2.4 Accessories

You can find information about the available accessories in the following chapters.

### 2.4.1 Safety technology

#### Information

The drive controller is delivered in the standard design without safety technology (option SZ6). If you want a drive controller with integrated safety technology, you must order it together with the drive controller. The safety modules are an integrated part of the drive controllers and must not be modified.

#### SZ6 option – Without safety technology

ID No. 56660

Design without safety technology.

#### SX6 safety module – Extended safety technology using FSoE

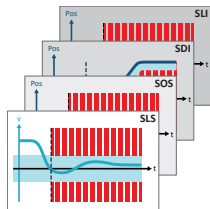

ID No. 5050185

Optional accessory for use in safety-related applications up to PL e, SIL 3 in accordance with EN ISO 13849-1 and EN 61800-5-2. In addition to the basic Safe Torque Off (STO) safety function, SX6 provides other safety functions specified in EN 61800-5-2. In addition to the safe stop functions Safe Stop 1 (SS1) and Safe Stop 2 (SS2), these also include Safely-Limited Speed (SLS), Safe Brake Control (SBC), Safe Brake Test (SBT), Safe Direction (SDI) and Safely-Limited Increment (SLI). Connection to the higher-level safety circuit using Fail Safe over EtherCAT (FSoE).

#### SR6 safety module – STO using terminals



ID No. 56661

Optional accessory for the use of the Safe Torque Off safety function (STO) in safety-relevant applications (PL e, SIL 3) in accordance with EN ISO 13849-1 and EN 61800-5-2. Connection to a higher-level safety circuit via terminal X12.

#### SY6 safety module – STO and SS1 using FSoE



ID No. 56662

Optional accessory for the use of the Safe Torque Off (STO) and Safe Stop 1 (SS1) safety functions in safety-relevant applications (PL e, SIL 3) in accordance with EN ISO 13849-1 and EN 61800-5-2. Connection to the higher-level safety circuit using Fail Safe over EtherCAT (FSoE).

#### SU6 safety module – STO and SS1 using PROFIsafe



ID No. 56696

Optional accessory for the use of the Safe Torque Off (STO) and Safe Stop 1 (SS1) safety functions in safety-relevant applications (PL e, SIL 3) in accordance with EN ISO 13849-1 and EN 61800-5-2. Connection to a higher-level safety circuit via PROFINET (PROFIsafe).

## 2.4.2 Communication

The drive controller has two interfaces for the EtherCAT or PROFINET connection on the top of the device as well as an Ethernet service interface on the front of the device. Cables for the connection are available separately.

### EtherCAT or PROFINET



Specify the desired fieldbus system when placing your order for the base device, since fieldbus communication is defined by the firmware.



### EtherCAT cables



Ethernet patch cable, CAT5e, yellow.  
The following designs are available:  
ID no. 49313: length approx. 0.25 m.  
ID no. 49314: length approx. 0.5 m.

### PC connecting cable



ID No. 49857  
Cable for connecting the X9 service interface to the PC, CAT5e, blue, length: 5 m.

### USB 2.0 Ethernet adapter



ID No. 49940  
Adapter for connecting Ethernet to a USB port.

## 2.4.3 Terminal set

For connection, you need a fitting terminal set for each SB6 drive controller.

### Terminal set for drive controllers (standard version)

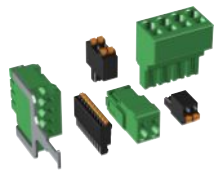

(Fig. similar)

The following designs are available:  
ID No. 138711  
Terminal set for SB6A06Z/U/Y/X.  
ID No. 138712  
Terminal set for SB6A16Z/U/Y/X.  
ID No. 138713  
Terminal set for SB6A26Z/U/Y/X.  
Contents: 10 terminals.

### Terminal set for drive controllers with SR6 safety module (STO using terminals)

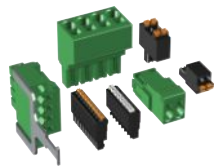

(Fig. similar)

The following designs are available:  
ID No. 138717  
Terminal set for SB6A06 with SR6.  
ID No. 138718  
Terminal set for SB6A16 with SR6.  
ID No. 138719  
Terminal set for SB6A26 with SR6.  
Contents: 11 terminals.

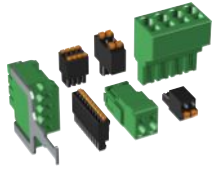
**Terminal set for drive controllers with XB6 terminal module**

(Fig. similar)

The following designs are available:

ID No. 138720

Terminal set for SB6A06Z/U/Y/X with XB6.

ID No. 138721

Terminal set for SB6A16Z/U/Y/X with XB6.

ID No. 138722

Terminal set for SB6A26Z/U/Y/X with XB6.

Contents: 12 terminals.

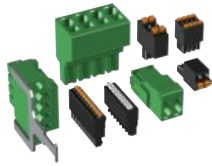
**Terminal set for drive controllers with SR6 safety module (STO using terminals) and XB6 terminal module**

(Fig. similar)

The following designs are available:

ID No. 138723

Terminal set for SB6A06 with SR6 and XB6.

ID No. 138724

Terminal set for SB6A16 with SR6 and XB6.

ID No. 138725

Terminal set for SB6A26 with SR6 and XB6.

Contents: 13 terminals.

Note that the basic device is delivered without terminals. Suitable terminal sets can be ordered with the drive controllers or as separate accessories.

## 2.4.4 Terminal module

**XB6 terminal module**

ID No. 5050181

Optional terminal module for connecting analog and digital signals as well as encoders.

Inputs and outputs:

- 8 digital inputs ( $24 V_{DC}$ )
- 8 digital outputs ( $24 V_{DC}$ )
- 2 analog inputs ( $\pm 10 V_{DC}$ ,  $1 \times \pm 20 \text{ mA}$ , 16 bits)
- 2 analog outputs ( $\pm 10 V_{DC}$ ,  $\pm 20 \text{ mA}$ , 12 bits)

Supported encoders and interfaces:

- Resolver (evaluation)
- EnDat 2.1 sin/cos encoder (evaluation)
- Sin/cos encoder (evaluation)
- EnDat 2.1/2.2 digital encoder (evaluation)
- SSI encoder (SSI motion bus, evaluation, simulation and SSI passive)
- Differential TTL incremental encoder (evaluation and simulation)
- Differential TTL pulse/direction interface (evaluation and simulation)

**X120 SSI/TTL connecting cable**

ID No. 49482

Cable for connecting the X120 interface for TTL incremental signals and SSI signals. Can be used in conjunction with the RI6 and XI6 G5 terminal modules, the SB6 XB6 terminal module and the X301 interface of the LA6 adapter box, length: 0.3 m.

## 2.4.5 Braking resistor

In addition to drive controllers, STÖBER offers the following braking resistors described below in various sizes and performance classes. For the selection, note the minimum permitted braking resistors specified in the technical data of the individual drive controller types.

### 2.4.5.1 Tubular fixed resistor FZMU, FZZMU

Type	FZMU 400×65		FZZMU 400×65	
ID No.	49010	55445	53895	55447
SB6A06	X	—	—	—
SB6A16	(X)	—	X	—
SB6A26	(—)	X	(X)	X

Tab. 29: Assignment of FZMU, FZZMU braking resistor – SB6 drive controller

X	Recommended
(X)	Possible
(—)	Useful under certain conditions
—	Not possible

#### Properties

Technical data	FZMU 400×65		FZZMU 400×65	
ID No.	49010	55445	53895	55447
Type	Tubular fixed resistor		Tubular fixed resistor	
Resistance [Ω]	100 ± 10 %	22 ± 10 %	47 ± 10 %	22 ± 10 %
Thermal drift	±10 %		±10 %	
Power [W]	600		1200	
Therm. time const.	40		40	
$\tau_{th}$ [s]				
Pulse power for < 1 s [kW]	18		36	
$U_{max}$ [V]	848		848	
Weight without packaging [g]	2200		4170	
Protection class	IP20		IP20	
Marks and test symbols	cURus, CE, UKCA		cURus, CE, UKCA	

Tab. 30: FZMU, FZZMU technical data

Dimensions

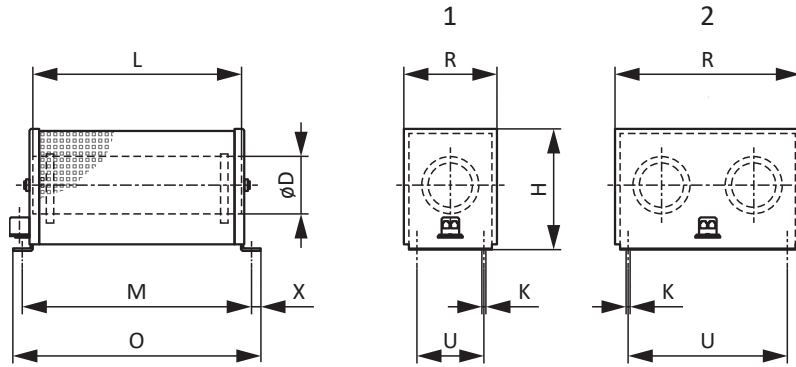

Fig. 3: FZMU (1), FZZMU (2) dimensional drawing

Dimension	FZMU 400×65		FZZMU 400×65	
	49010	55445	53895	55447
L x D	400 × 65		400 × 65	
H	120		120	
K	6.5 × 12		6.5 × 12	
M	430		426	
O	485		485	
R	92		185	
U	64		150	
X	10		10	

Tab. 31: FZMU, FZZMU dimensions [mm]

## 2.4.5.2 GVADU, GBADU flat resistor

Type	GVADU 210×20	GBADU 265×30	GBADU 335×30	GBADU 265×30
ID No.	55441	55442	55443	55444
SB6A06	X	X	—	—
SB6A16	(X)	(X)	X	—
SB6A26	(—)	(—)	(X)	X

Tab. 32: Assignment of GVADU, GBADU braking resistor – SB6 drive controller

X	Recommended
(X)	Possible
(—)	Useful under certain conditions
—	Not possible

## Properties

Technical data	GVADU 210×20	GBADU 265×30	GBADU 335×30	GBADU 265×30
ID No.	55441	55442	55443	55444
Type	22 ± 10 %			
Resistance [Ω]	100 ± 10 %	100 ± 10 %	47 ± 10 %	22 ± 10 %
Thermal drift	±10 %	±10 %	±10 %	±10 %
Power [W]	150	300	400	300
Therm. time const. $\tau_{th}$ [s]	60	60	60	60
Pulse power for < 1 s [kW]	3.3	6.6	8.8	6.6
$U_{max}$ [V]	848	848	848	848
Cable design	Radox	FEP	FEP	FEP
Cable length [mm]	500	1500	1500	1500
Conductor cross-section [AWG]	18/19 (0.82 mm <sup>2</sup> )	14/19 (1.9 mm <sup>2</sup> )	14/19 (1.9 mm <sup>2</sup> )	14/19 (1.9 mm <sup>2</sup> )
Weight without packaging [g]	300	930	1200	930
Protection class	IP54	IP54	IP54	IP54
Marks and test symbols	cURus, CE, UKCA			

Tab. 33: GVADU, GBADU technical data

Dimensions

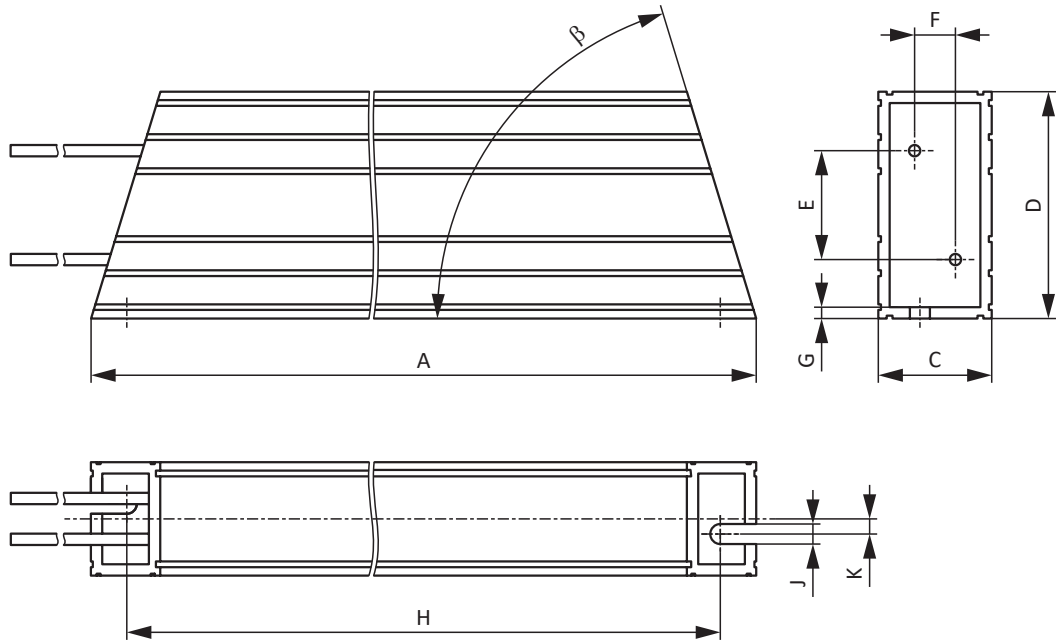

Fig. 4: GVADU, GBADU dimensional drawing

Dimension	GVADU 210×20	GBADU 265×30	GBADU 335×30	GBADU 265×30
ID No.	55441	55442	55443	55444
A	210	265	335	265
H	192	246	316	246
C	20	30	30	30
D	40	60	60	60
E	18.2	28.8	28.8	28.8
F	6.2	10.8	10.8	10.8
G	2	3	3	3
K	2.5	4	4	4
J	4.3	5.3	5.3	5.3
β	65°	73°	73°	73°

Tab. 34: GVADU, GBADU dimensions [mm]

### 2.4.5.3 RB 5000 rear section braking resistor

Type	RB 5022	RB 5047	RB 5100
ID No.	45618	44966	44965
SB6A06	—	—	X
SB6A16	—	X	(X)
SB6A26	X	—	—

Tab. 35: Assignment of RB 5000 braking resistor – SB6 drive controller

X	Recommended
(X)	Possible
—	Not possible

#### Properties

Technical data	RB 5022	RB 5047	RB 5100
ID No.	45618	44966	44965
Resistance [ $\Omega$ ]	22 $\pm$ 10 %	47 $\pm$ 10 %	100 $\pm$ 10 %
Thermal drift	$\pm$ 10 %	$\pm$ 10 %	$\pm$ 10 %
Power [W]	100	60	60
Therm. time const. $\tau_{th}$ [s]	8	8	8
Pulse power for < 1 s [kW]	1.5	1.0	1.0
$U_{max}$ [V]	800	800	800
Weight without packaging [g]	640	460	440
Cable design	Radox	Radox	Radox
Cable length [mm]	250	250	250
Conductor cross-section [AWG]	18/19 (0.82 mm <sup>2</sup> )	18/19 (0.82 mm <sup>2</sup> )	18/19 (0.82 mm <sup>2</sup> )
Maximum torque of M5 threaded bolts [Nm]	5	5	5
Protection class	IP40	IP40	IP40
Marks and test symbols	cURus, CE, UKCA	cURus, CE, UKCA	cURus, CE, UKCA

Tab. 36: RB 5000 technical data

#### Dimensions

Dimension	RB 5022	RB 5047	RB 5100
ID No.	45618	44966	44965
Height	300	300	300
Width	94	62	62
Depth	18	18	18
Drilling diagram corresponds to size	Size 2	Size 1	Size 0 and Size 1

Tab. 37: RB 5000 dimensions [mm]

## 2.4.6 Choke

Technical specifications for suitable chokes can be found in the following chapters.

### 2.4.6.1 TEP output choke

Output chokes are required for connecting size 0 to 2 drive controllers to synchronous servo motors or asynchronous motors from a cable length > 50 m in order to reduce interference pulses and protect the drive system. If Lean motors are connected, output chokes must not be used.

#### Information

The following technical data only applies to a rotating magnetic field frequency of 200 Hz. For example, this rotating magnetic field frequency is achieved with a motor with 4 pole pairs and a nominal speed of 3000 rpm. Always observe the specified derating for higher rotating magnetic field frequencies. Also observe the relationship with the clock frequency.

#### Properties

Technical data	TEP3720-0ES41	TEP3820-0CS41	TEP4020-0RS41
ID No.	53188	53189	53190
Voltage range	3 × 0 to 480 V <sub>AC</sub>		
Frequency range	0 – 200 Hz		
Nominal current I <sub>N,MF</sub> at 4 kHz	4 A	17.5 A	38 A
Nominal current I <sub>N,MF</sub> at 8 kHz	3.3 A	15.2 A	30.4 A
Max. permitted motor cable length with output choke	100 m		
Max. surrounding temperature $\vartheta_{amb,max}$	40 °C		
Protection class	IP00		
Winding losses	11 W	29 W	61 W
Iron losses	25 W	16 W	33 W
Connection	Screw terminal		
Max. conductor cross-section	10 mm <sup>2</sup>		
UL Recognized	Yes		
Component (CAN; USA)			
Marks and test symbols	cURus, CE		

Tab. 38: TEP technical data

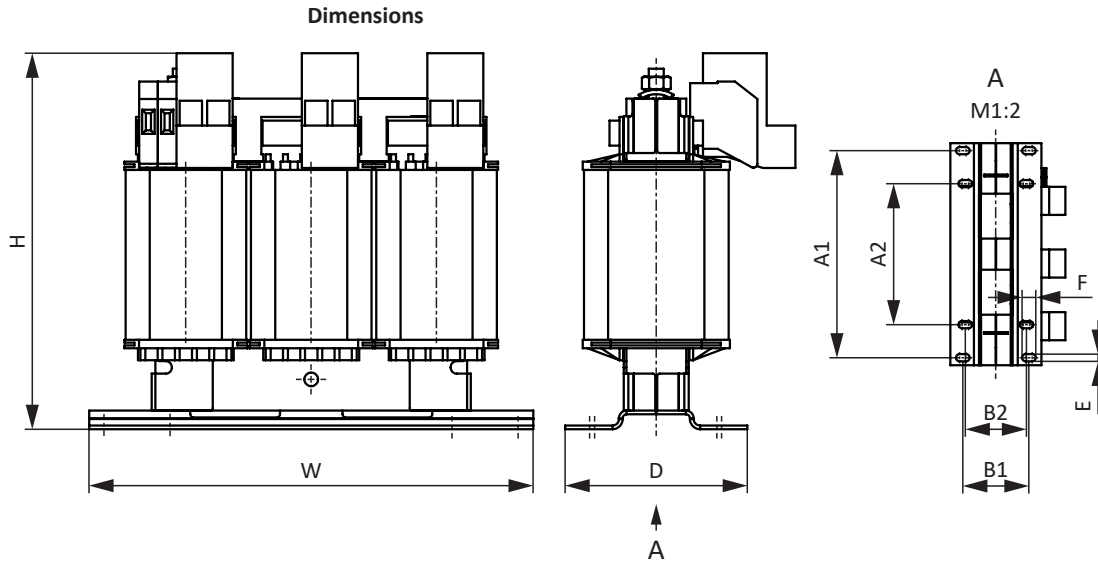

Fig. 5: TEP dimensional drawing

Dimension	TEP3720-0ES41	TEP3820-0CS41	TEP4020-0RS41
Height H [mm]	Max. 150	Max. 152	Max. 172
Width W [mm]	178	178	219
Depth D [mm]	73	88	119
Vertical distance – A1 fastening bores [mm]	166	166	201
Vertical distance – A2 fastening bores [mm]	113	113	136
Horizontal distance – B1 fastening bores [mm]	53	68	89
Horizontal distance – B2 fastening bores [mm]	49	64	76
Drill holes – Depth E [mm]	5.8	5.8	7
Drill holes – Width F [mm]	11	11	13
Screw connection – M	M5	M5	M6
Weight without packaging [g]	2900	5900	8800

Tab. 39: TEP dimensions and weight

## 2.4.7 EMC shield plate

As an alternative to shield contact at terminal X20 of the drive controller, you can use the following shield plate to connect the cable shield of the power cable.

### EM6A0 EMC shield plate



ID No. 135115

EMC shield plate for SB6 and SD6 series drive controllers up to size 2.

Accessory part for shield connection of the power cable.

Can be attached to the drive controller housing.

Including shield connection terminal.

## 2.5 Further information

### 2.5.1 Directives and standards

The following European directives and standards are relevant to the drive controllers:

- Directive 2006/42/EC – Machinery Directive
- Directive 2014/30/EU – EMC Directive
- Directive 2011/65/EU – RoHS Directive
- Directive 2009/125/EC – Ecodesign Directive
- EN IEC 61800-3:2018
- EN 61800-5-1:2007 + A1:2017
- EN 61800-5-2:2017
- EN IEC 63000:2018
- EN ISO 13849-1:2015

### 2.5.2 Marks and test symbols

The following marks and test symbols are mentioned in the technical data.



#### RoHS lead-free mark

Marking in accordance with RoHS directive 2011-65-EU.



#### CE mark

Manufacturer's self declaration: The product meets the requirements of EU directives.



#### UL test symbol (cULus)

This product is listed by UL for the United States and Canada.

Representative samples of this product have been evaluated by UL and meet the requirements of applicable standards.



#### UL recognized component mark (cURus)

This component or material is recognized by UL for the US and Canada.

Representative samples of this product have been evaluated by UL and meet applicable requirements.

### 2.5.3 Additional documentation

Additional documentation related to the product can be found at

<http://www.stoeber.de/en/downloads/>

Enter the ID of the documentation in the Search term field.

Documentation	ID
SB6 drive controller manual	443340



# 3 SC6 drive controllers

## Table of contents

3.1	Overview .....	46
3.1.1	Features.....	47
3.1.2	Software components .....	48
3.1.3	Operating motors, encoders and brakes.....	49
3.1.4	Application training.....	49
3.2	Technical data .....	50
3.2.1	Type designation .....	50
3.2.2	Sizes.....	50
3.2.3	General technical data .....	51
3.2.4	Electrical data.....	52
3.2.5	Cycle times .....	57
3.2.6	Derating.....	57
3.2.7	Dimensions.....	59
3.2.8	Weight.....	59
3.2.9	Minimum clearances.....	60
3.3	Drive controller/motor combinations.....	61
3.4	Accessories .....	64
3.4.1	Safety technology.....	64
3.4.2	Communication .....	65
3.4.3	Terminal set.....	65
3.4.4	DC link connection.....	66
3.4.5	Braking resistor .....	67
3.4.6	Choke .....	70
3.4.7	HTL-to-TTL adapter.....	71
3.5	Further information .....	72
3.5.1	Directives and standards.....	72
3.5.2	Marks and test symbols .....	72
3.5.3	Additional documentation .....	72



## 3 Drive controllers

# SC6

### 3.1 Overview

The innovative one for economical application concepts

#### Features

- Single or double-axis controller with a nominal output current up to 19 A and 250% overload capacity
- Sensorless position control of Lean motors
- Control of rotary synchronous servo motors and asynchronous motors
- Control of linear and torque motors
- One Cable Solution EnDat 3
- Electronic motor nameplate via EnDat encoder interfaces
- Integrated EtherCAT or PROFINET communication
- STO safety technology using terminals or STO and SS1 using FSoE or PROFIsafe: SIL 3, PL e (Cat. 4)
- Extended safety technology (SS1, SS2, SLS, SBC, SBT...) using FSoE
- Integrated brake control
- Single-ended nominal power consumption on double-axis controllers for operation of motors with different power
- Energy supply through direct power feed-in
- Flexible DC link connection for multi-axis applications
- Available EPLAN macros in the EPLAN Data Portal

## 3.1.1 Features

The stand-alone SC6 drive controller enables extremely economical system designs due to its integrated power supply and slim design. The SC6 series is ideal for combination with the innovative Lean motor – for example, for energy-efficient transport systems. Another benefit is that the Lean motor and SC6 run completely without an encoder! However, the SC6 can also be used in combination with asynchronous motors or synchronous servo motors with encoders (e.g. the EZ series). SC6 is available in three sizes with a nominal output current of up to 19 A: Sizes 0 and 1 as a double-axis controller, size 2 as a single-axis controller.

For STOBBER synchronous servo motors, we recommended operation with the EnDat 2.2 digital encoder or as a One Cable Solution with EnDat 3. These encoder systems make it possible to attain the highest control quality. It is possible to perform motor parameterization automatically from the electronic motor name-plate.



*The compact SC6 for Lean motors of the LM series*

### Quick DC-Link

The drive controllers have the option of a DC link connection. This technology makes it possible for the regenerative production of energy from one drive to be used as motor energy by another drive, improving the energy efficiency of the application. The Quick DC-Link rear structure element has been developed for setting up a reliable and efficient rail connection to the DC link connection. This optionally available accessory connects the DC links of the individual drive controllers by means of copper rails that can carry a load of up to 200 A. The rails can be attached without any tools using quick fastening clamps.

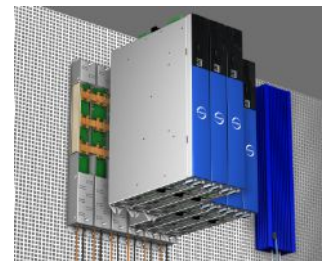

### Perfectly adapted combinations

SC6 drive controllers can be combined with the STOBBER SI6 and SD6 series as needed. For the general energy supply, the drive controllers from the SC6, SI6 and SD6 series are connected to each other using Quick DC-Link modules.

### Tailored energy usage

When using double-axis modules, the unused power reserves of one axis can be used for other axes.

### Precise dynamics

The drive controller provides acceleration that is literally as fast as lightning. For example, in conjunction with the STOBBER EZ401 synchronous servo motor: from 0 to 3000 rpm in 10 ms.

**Easy connection, quick and safe parameterization**

The One Cable Solution (OCS) from STOBBER combines power and encoder communication in a single hybrid cable – for minimal cabling and easy installation.

The electronic motor nameplate is automatically transmitted via the digital EnDat 3 interface. The drive controller detects all the motor data automatically – the parameterization process is fast, reliable and error-free.

The optimized hybrid cable offers maximum signal quality and system reliability.

Ready-to-connect power and encoder cables with an EnDat 2.2 interface and electronic nameplate function are available as alternatives. Both variants ensure optimal coordination of the interaction between the motor and drive controller – for efficient and reliable commissioning.

**Play it safe with STOBBER****Integrated safety**

STOBBER drive controllers have safety functions such as Safe Torque Off (STO) and Safe Stop 1 (SS1) – which can be controlled either conventionally via terminals, or via the safe communication standards PROFIsafe (PROFINET) and Fail Safe over EtherCAT (FSoE). The fully electronic design is fast and free of wear. Additional cyclical function tests are no longer necessary. This increases availability and reduces the amount of testing required during operation.

**Extended safety**

For stricter requirements, STOBBER offers optional safety functions up to SIL 3, PL e (category 4). In addition to STO, which can be activated for each axis individually in multi-axis systems, extended functions such as Safely Limited Speed (SLS), Safe Operating Stop (SOS), Safe Brake Control (SBC) and Safe Brake Test (SBT) are also available. Optimized monitoring mechanisms ensure short reaction times, minimum safety distances and increased system availability – for productive safety at the highest level.

**Robust and resilient**

The drive controllers boast a stable, durable design. The housing is made from high-quality sheet steel for reliable shielding, mechanical strength and optimum heat dissipation – even under demanding operating conditions. Inside, powerful computing units, carefully selected components and precision manufacturing ensure reliable operation over the long term.

An SD card slot is available on the front panel for removable data storage. An SD card can be used for quick series commissioning by copying, or for easy device replacement in the event of servicing. The removable data storage can also be used as a medium for storing additional project data and documentation.

## 3.1.2 Software components

**Project configuration and commissioning**

The DriveControlSuite project configuration and commissioning software has all the functions for the efficient use of drive controllers in single-axis and multi-axis applications. The program guides you step by step through the complete project configuration and parameterization process using wizards.

**Open communication**

The Ethernet-based EtherCAT and PROFINET fieldbus systems are available in the drive controller.

**Applications**

A drive-based application is recommended for the decentralized motion control of sophisticated machines.

The drive-based application package from STOBBER is the right choice wherever universal and flexible solutions are needed. The Drive Based application provides drive-based motion control for positioning, velocity and torque/force with the PLCopen Motion Control command set. These standard commands have been combined into operating modes for different applications and supplemented with additional functions such as motion block linking, cams and much more. For the command operating mode, all properties of the movements are specified directly by the controller. The properties of the movements in the drive are predefined in the motion block operating mode so that only a start signal is necessary to perform the movement. Linking can be used to define complete motion sequences. There is a separate operating mode available for applications controlled by velocity or torque/force such as pumps, fans or conveyor belts. This also allows for operation without a controller.

In addition, the CiA 402 and PROFIdrive applications are also available, which include both the controller-based and drive-based operating modes and application classes. For example, standard telegrams 1, 2 and 3 as well as telegrams 102 and 111 are available for standard drives according to PROFIdrive in application class 1 and for decentralized positioning control according to application class 3. Based on these telegrams, the drive controllers can be used with the SpeedAxis and BasicPos (EPos) technology objects.

Standard telegrams 3 and 5 as well as telegram 105 are available for controller-based motion control according to PROFIdrive in application class 4.

Furthermore, programming based on IEC 61131-3 with CFC can be used to create new applications or expand existing ones.

### 3.1.3 Operating motors, encoders and brakes

You can use the drive controller to operate Lean motors of the LM series, synchronous servo motors (such as those of the EZ series), asynchronous motors, linear motors or torque motors.

Evaluation options for feedback are available on the X4 connection for the following encoders:

- EnDat 2.1/2.2 digital encoders
- SSI encoders
- Differential TTL and differential HTL incremental encoders (HTL via HT6 adapter)
- Resolver
- EnDat 3 or HIPERFACE DSL encoder (with One Cable Solution design)

In addition, evaluation options for the following encoders are available on the X101 and X103 connection:

- Single-ended HTL incremental encoders
- Single-ended HTL pulse/direction interface

All device types of the drive controller have connections for PTC thermistors and can control a 24 V<sub>DC</sub> brake as standard.

### 3.1.4 Application training

STOBER offers a multi-level training program that is essentially focused on the drive controller.

#### G6 Basic

Training content: System overview, installation and commissioning of the drive controller. Use of option modules. Parameterization, commissioning and diagnostics using the commissioning software. Remote maintenance. Basics of controller optimization. Configuration of the drive train. Integrated software functions. Software applications. Connection to a higher-level controller. Basics of safety technology. Practical exercises on training topics.

Software used: DriveControlSuite.

#### G6 Customized

Training content: Special knowledge for regulating, control and safety technology. Practical exercises on training topics.

## 3.2 Technical data

Technical data for the drive controller can be found in the following chapters.

### 3.2.1 Type designation

SC	6	A	0	6	2	Z
----	---	---	---	---	---	---

Tab. 1: Example code for type designation

Code	Designation	Design
SC	Series	
6	Generation	Generation 6
A	Version	
0 – 2	Size	
6	Power output stage	Power output stage within the size
2	Axis controller	Double-axis controller
1		Single-axis controller
Z	Safety technology	SZ6: Without safety technology
R		SR6: STO using terminals
U		SU6: STO and SS1 using PROFIsafe
Y		SY6: STO and SS1 using FSoE
X		SX6: Extended safety technology using FSoE

Tab. 2: Meaning of the example code

### 3.2.2 Sizes

Type	ID No.	Size	Axis controller
SC6A062	56690	Size 0	Double-axis controller
SC6A162	56691	Size 1	Double-axis controller
SC6A261	56692	Size 2	Single-axis controller

Tab. 3: Available SC6 types and sizes



SC6 in sizes 0 to 2

Note that the basic device is delivered without terminals. Suitable terminal sets are available separately for each size.

### 3.2.3 General technical data

The following information applies to all device types.

Device features	
Protection class of the device	IP20
Protection class of the installation space	At least IP54
Protection class	Protection class I in accordance with EN 61140
Radio interference suppression	Integrated line filter in accordance with EN 61800-3, interference emission class C3
Overvoltage category	III in accordance with EN 61800-5-1
Marks and test symbols	CE, cULus, RoHS

Tab. 4: Device features

Transport and storage conditions	
Storage/transport temperature	-20 °C to +70 °C Maximum change: 20 K/h
Relative humidity	Maximum relative humidity 85%, non-condensing
Vibration (transport) in accordance with EN 60068-2-6	5 Hz ≤ f ≤ 9 Hz: 3.5 mm 9 Hz ≤ f ≤ 200 Hz: 10 m/s <sup>2</sup> 200 Hz ≤ f ≤ 500 Hz: 15 m/s <sup>2</sup>
Fall height for free fall <sup>1</sup> Weight < 100 kg in accordance with EN 61800-2 (or IEC 60721-3-2, class 2M4)	0.25 m
Shock testing in accordance with EN 60068-2-27	Pulse shape: Half-sine Acceleration: 5 g Shock duration: 30 ms Number of shocks: 3 per axis

Tab. 5: Transport and storage conditions

Operating conditions	
Surrounding temperature during operation	0 °C to 45 °C with nominal data 45 °C to 55 °C with derating -2.5% / K
Relative humidity	Maximum relative humidity 85%, non-condensing
Installation altitude	0 m to 1000 m above sea level without restrictions 1000 m to 2000 m above sea level with -1.5%/100 m derating
Pollution degree	Pollution degree 2 in accordance with EN 50178
Ventilation	Installed fan
Vibration (operation) in accordance with EN 60068-2-6	5 Hz ≤ f ≤ 9 Hz: 0.35 mm 9 Hz ≤ f ≤ 200 Hz: 1 m/s <sup>2</sup>

Tab. 6: Operating conditions

Discharge times	
Self-discharge of DC link	15 min

Tab. 7: Discharge times of the DC link circuit

<sup>1</sup>Only valid for components in their original packaging.

### 3.2.4 Electrical data

The electrical data of the available sizes as well as the properties of the brake chopper can be found in the following chapters.

An explanation of the symbols used for formulas can be found in Chapter [\[ 9.1 \]](#).

#### 3.2.4.1 Control unit

Electrical data	All types
$U_{1CU}$	24 V <sub>DC</sub> , +20%/–15%
$I_{1maxCU}$	1.5 A

Tab. 8: Control unit electrical data

#### 3.2.4.2 Power unit: Size 0

Electrical data	SC6A062
$U_{1PU}$	3 × 400 V <sub>AC</sub> , +32% / –50%, 50/60 Hz; 3 × 480 V <sub>AC</sub> , +10% / –58%, 50/60 Hz
$f_{2PU}$	0 – 700 Hz
$U_{2PU}$	0 – max. $U_{1PU}$
$U_{2PU,ZK}$	$\sqrt{2} \times U_{1PU}$
$C_{PU}$	270 μF
$C_{N,PU}$	1400 μF
$C_{maxPU}$	1880 μF

Tab. 9: SC6 electrical data, size 0

The charging capacity depends on the time between two energizing processes:

#### Information

For the maximum charging capacity  $C_{maxPU}$ , a time span of ≥ 15 min must be maintained between two energizing processes.

#### Nominal currents up to +45 °C (in the control cabinet)

Electrical data	SC6A062
$f_{PWM,PU}$	4 kHz
$I_{1N,PU}$	10 A
$I_{2N,PU}$	2 × 4.5 A
$I_{2maxPU}$	210% for 2 s; 150% for 30 s

Tab. 10: SC6 electrical data, size 0, for 4 kHz clock frequency

Electrical data	SC6A062
$f_{PWM,PU}$	8 kHz
$I_{1N,PU}$	8.9 A
$I_{2N,PU}$	2 × 4 A
$I_{2maxPU}$	250% for 2 s; 200% for 5 s

Tab. 11: SC6 electrical data, size 0, for 8 kHz clock frequency

Electrical data	SC6A062
$U_{onCH}$	780 – 800 V <sub>DC</sub>
$U_{offCH}$	740 – 760 V <sub>DC</sub>
$R_{2minRB}$	100 Ω
$P_{maxRB}$	6.4 kW
$P_{effRB}$	2.9 kW

Tab. 12: Brake chopper electrical data, size 0

### 3.2.4.3 Power unit: Size 1

Electrical data	SC6A162
$U_{1PU}$	$3 \times 400 V_{AC}$ , +32% / -50%, 50/60 Hz; $3 \times 480 V_{AC}$ , +10% / -58%, 50/60 Hz
$f_{2PU}$	0 – 700 Hz
$U_{2PU}$	0 – max. $U_{1PU}$
$U_{2PU,ZK}$	$\sqrt{2} \times U_{1PU}$
$C_{PU}$	940 $\mu F$
$C_{N,PU}$	1400 $\mu F$
$C_{maxPU}$	1880 $\mu F$

Tab. 13: SC6 electrical data, size 1

The charging capacity depends on the time between two energizing processes:

#### Information

For the maximum charging capacity  $C_{maxPU}$ , a time span of  $\geq 15$  min must be maintained between two energizing processes.

#### Nominal currents up to +45 °C (in the control cabinet)

Electrical data	SC6A162
$f_{PWM,PU}$	4 kHz
$I_{1N,PU}$	23.2 A
$I_{2N,PU}$	$2 \times 10$ A
$I_{2maxPU}$	210% for 2 s; 150% for 30 s

Tab. 14: SC6 electrical data, size 1, for 4 kHz clock frequency

Electrical data	SC6A162
$f_{PWM,PU}$	8 kHz
$I_{1N,PU}$	20.9 A
$I_{2N,PU}$	$2 \times 9$ A
$I_{2maxPU}$	250% for 2 s; 200% for 5 s

Tab. 15: SC6 electrical data, size 1, for 8 kHz clock frequency

Electrical data	SC6A162
$U_{onCH}$	780 – 800 $V_{DC}$
$U_{offCH}$	740 – 760 $V_{DC}$
$R_{2minRB}$	47 $\Omega$
$P_{maxRB}$	13.6 kW
$P_{effRB}$	6.2 kW

Tab. 16: Brake chopper electrical data, size 1

## 3.2.4.4 Power unit: Size 2

Electrical data	SC6A261
$U_{1PU}$	$3 \times 400 V_{AC}$ , +32% / -50%, 50/60 Hz; $3 \times 480 V_{AC}$ , +10% / -58%, 50/60 Hz
$f_{2PU}$	0 – 700 Hz
$U_{2PU}$	0 – max. $U_{1PU}$
$U_{2PU,ZK}$	$\sqrt{2} \times U_{1PU}$
$C_{PU}$	940 $\mu$ F
$C_{N,PU}$	1400 $\mu$ F
$C_{maxPU}$	1880 $\mu$ F

Tab. 17: SC6 electrical data, size 2

The charging capacity depends on the time between two energizing processes:

<b>Information</b>
--------------------

For the maximum charging capacity  $C_{maxPU}$ , a time span of  $\geq 15$  min must be maintained between two energizing processes.

## Nominal currents up to +45 °C (in the control cabinet)

Electrical data	SC6A261
$f_{PWM,PU}$	4 kHz
$I_{1N,PU}$	22.6 A
$I_{2N,PU}$	19 A
$I_{2maxPU}$	210% for 2 s; 150% for 30 s

Tab. 18: SC6 electrical data, size 2, for 4 kHz clock frequency

Electrical data	SC6A261
$f_{PWM,PU}$	8 kHz
$I_{1N,PU}$	17.9 A
$I_{2N,PU}$	15 A
$I_{2maxPU}$	250% for 2 s; 200% for 5 s

Tab. 19: SC6 electrical data, size 2, for 8 kHz clock frequency

Electrical data	SC6A261
$U_{onCH}$	780 – 800 $V_{DC}$
$U_{offCH}$	740 – 760 $V_{DC}$
$R_{2minRB}$	47 $\Omega$
$P_{maxRB}$	13.6 kW
$P_{effRB}$	6.2 kW

Tab. 20: Brake chopper electrical data, size 2

### 3.2.4.5 DC link connection

The charging capacity of the drive controllers can be increased by a DC link connection only if the power supply is connected to all drive controllers simultaneously.

### 3.2.4.6 Single-ended nominal power consumption on double-axis controllers

Operating two motors on one double-axis controller makes it possible to operate one of the motors with a continuous current above the nominal current of the drive controller if the continuous current of the second connected motor is lower than the nominal current of the drive controller. This enables economical combinations of double-axis controllers and motors.

An explanation of the symbols used for formulas can be found in Chapter [\[ 9.1 \]](#).

The nominal output current for axis B can be determined using the following formula if the output current for axis A is known:

#### Formula 1

$$I_{2PU(B)} = I_{2N,PU} - (I_{2PU(A)} - I_{2N,PU}) \times \frac{3}{5} \quad \text{for} \quad 0 \leq I_{2PU(A)} \leq I_{2N,PU}$$

#### Formula 2

$$I_{2PU(B)} = I_{2N,PU} - (I_{2PU(A)} - I_{2N,PU}) \times \frac{5}{3} \quad \text{for} \quad I_{2N,PU} \leq I_{2PU(A)} \leq 1,6 \times I_{2N,PU}$$

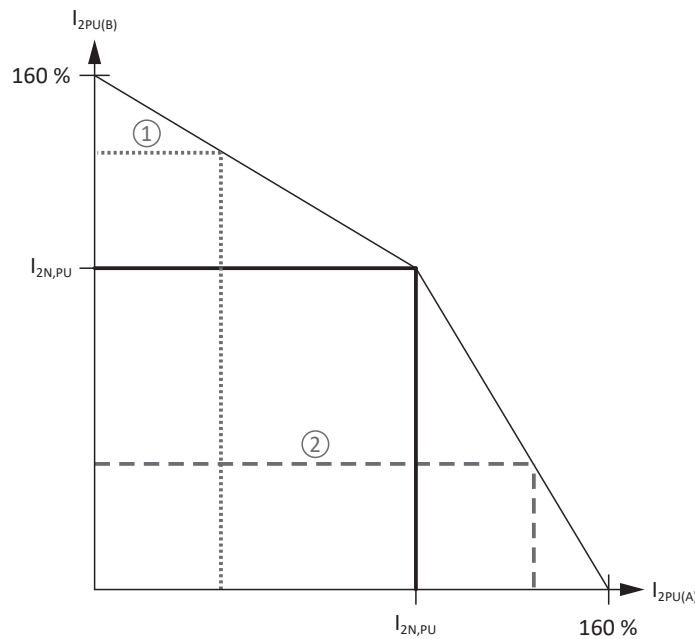

Fig. 1: Asymmetric load on double-axis controllers

#### Information

Note that the available maximum currents  $I_{2maxPU}$  of the axis controllers are also relative to the nominal output current  $I_{2N,PU}$  for single-ended nominal power consumption.

### 3.2.4.7 Power loss data in accordance with EN 61800-9-2

Type	Nominal current $I_{2N,PU}$	Apparent power	Absolute losses $P_{V,CU}^2$	Operating points <sup>3</sup>								IE class <sup>4</sup>	Comparison <sup>5</sup>
				(0/25)	(0/50)	(0/100)	(50/25)	(50/50)	(50/100)	(90/50)	(90/100)		
				Relative losses									
	[A]	[kVA]	[W]	[%]									
SC6A062	4.5	6.2	Max. 10	1.34	1.49	1.86	1.40	1.63	2.19	1.84	2.77	IE2	
SC6A162	10	13.9	Max. 10	0.76	0.92	1.43	0.81	1.04	1.75	1.22	2.29	IE2	
SC6A261	19	13.2	10	0.77	0.95	1.56	0.82	1.08	1.89	1.25	2.43	IE2	
				Absolute losses									
	[A]	[kVA]	[W]	$P_V$ [W]									[%]
SC6A062	4.5	6.2	Max. 10	83.2	92.5	115.2	86.7	100.8	135.8	113.9	171.7	IE2	36.0
SC6A162	10	13.9	Max. 10	105.5	128.3	198.8	113.1	145.1	243.5	170.1	318.7	IE2	40.8
SC6A261	19	13.2	Max. 10	101.2	125.8	206.1	108.5	142.0	249.5	165.6	320.4	IE2	41.0

Tab. 21: Power loss data of the SC6 drive controller in accordance with EN 61800-9-2

#### General conditions

The specified losses apply to a drive controller. They apply to both axes together in the case of double-axis controllers.

The power loss data applies to drive controllers without accessories.

The power loss calculation is based on a 3-phase supply voltage with 400 V<sub>AC</sub>/50 Hz.

The calculated data includes a supplement of 10% in accordance with EN 61800-9-2.

The power loss specifications refer to a clock frequency of 4 kHz.

The absolute losses for a power unit that is switched off refer to the 24 V<sub>DC</sub> power supply of the control electronics.

### 3.2.4.8 Power loss data of accessories

If you intend to order the drive controller with accessory parts, losses increase as follows.

Type	Absolute losses $P_V$ [W]
SR6 safety module	1
SY6 or SU6 safety module	2
SX6 safety module	< 4

Tab. 22: Absolute losses of the accessories

#### Information

Note the absolute power loss of the encoder (usually < 3 W) and of the brake when designing as well.

Loss specifications for other optional accessories can be found in the technical data of the respective accessory part.

<sup>2</sup> Absolute losses for a power unit that is switched off

<sup>3</sup> Operating points for relative motor stator frequency in % and relative torque current in %

<sup>4</sup> IE class in accordance with EN 61800-9-2

<sup>5</sup> Comparison of the losses for the reference related to IE2 in the nominal point (90, 100)

## 3.2.5 Cycle times

Possible cycle times can be found in the following table.

Type	Cycle times	Relevant parameters
Application	250 $\mu$ s, 500 $\mu$ s, 1 ms, 2 ms, 4 ms, 8 ms	Adjustable in A150
EtherCAT fieldbus, cyclical communication	250 $\mu$ s, 500 $\mu$ s, 1 ms, 2 ms, 4 ms, 8 ms	Adjustable in TwinCAT 3 or CODESYS
PROFINET RT fieldbus, cyclical communication	1 ms, 2 ms, 4 ms, 8 ms	Adjustable in the TIA Portal
PROFINET IRT fieldbus, cyclical communication	1 ms, 2 ms, 4 ms	Adjustable in the TIA Portal
Motion core (movement calculation)	250 $\mu$ s	—
Control cascade	62.5 $\mu$ s	B24 $\geq$ 8 kHz and B20 = 48, 64 or 70
	125 $\mu$ s	B24 = 4 kHz

Tab. 23: Cycle times

### Information

For Lean motors (control mode B20 = 32: LM - sensorless vector control), only operation at 4 kHz is permitted.

## 3.2.6 Derating

When dimensioning the drive controller, observe the derating of the nominal output current as a function of the clock frequency, surrounding temperature and installation altitude. There is no restriction for a surrounding temperature from 0 °C to 45 °C and an installation altitude of 0 m to 1000 m. The details given below apply to values outside these ranges.

### 3.2.6.1 Effect of the clock frequency

Changing the clock frequency  $f_{\text{PWM}}$  affects the amount of noise produced by the drive, among other things. However, increasing the clock frequency results in increased losses. During project configuration, define the highest clock frequency and use it to determine the nominal output current  $I_{2\text{N,PU}}$  for dimensioning the drive controller.

Type	$I_{2\text{N,PU}}$ 4 kHz [A]	$I_{2\text{N,PU}}$ 8 kHz [A]	$I_{2\text{N,PU}}$ 16 kHz [A]
SC6A062	2 × 4.5	2 × 4	2 × 3
SC6A162	2 × 10	2 × 9	2 × 5
SC6A261	19	15	8

Tab. 24: Nominal output current  $I_{2\text{N,PU}}$  dependent on the clock frequency

### 3.2.6.2 Effect of the surrounding temperature

Derating as a function of the surrounding temperature is determined as follows:

- 0 °C to 45 °C: No restrictions ( $D_T = 100\%$ )
- 45 °C to 55 °C: Derating  $-2.5\%/K$

#### Example

The drive controller needs to be operated at 50 °C.

The derating factor  $D_T$  is calculated as follows

$$D_T = 100\% - 5 \times 2.5\% = 87.5\%$$

### 3.2.6.3 Effect of the installation altitude

Derating as a function of the installation altitude is determined as follows:

- 0 m to 1000 m: No restriction ( $D_{IA} = 100\%$ )
- 1000 m to 2000 m: Derating  $-1.5\%/100$  m

#### Example

The drive controller needs to be installed at an altitude of 1500 m above sea level.

The derating factor  $D_{IA}$  is calculated as follows:

$$D_{IA} = 100\% - 5 \times 1.5\% = 92.5\%$$

### 3.2.6.4 Calculating the derating

Follow these steps for the calculation:

1. Determine the highest clock frequency ( $f_{PWM}$ ) that will be used during operation and use it to determine the nominal current  $I_{2N,PU}$ .
2. Determine the derating factors for installation altitude and surrounding temperature.
3. Calculate the reduced nominal current  $I_{2N,PU(red)}$  in accordance with the following formula:

$$I_{2N,PU(red)} = I_{2N,PU} \times D_T \times D_{IA}$$

#### Example

A drive controller of type SC6A062 needs to be operated at a clock frequency of 8 kHz at an altitude of 1500 m above sea level and a surrounding temperature of 50 °C.

The nominal current of the SC6A062 at 8 kHz is 4 A per axis. The derating factor  $D_T$  is calculated as follows:

$$D_T = 100\% - 5 \times 2.5\% = 87.5\%$$

The derating factor  $D_{IA}$  is calculated as follows:

$$D_{IA} = 100\% - 5 \times 1.5\% = 92.5\%$$

The output current of importance for the project configuration is:

$$I_{2N,PU(red)} = 4 \text{ A} \times 0.875 \times 0.925 = 3.24 \text{ A}$$

### 3.2.7 Dimensions

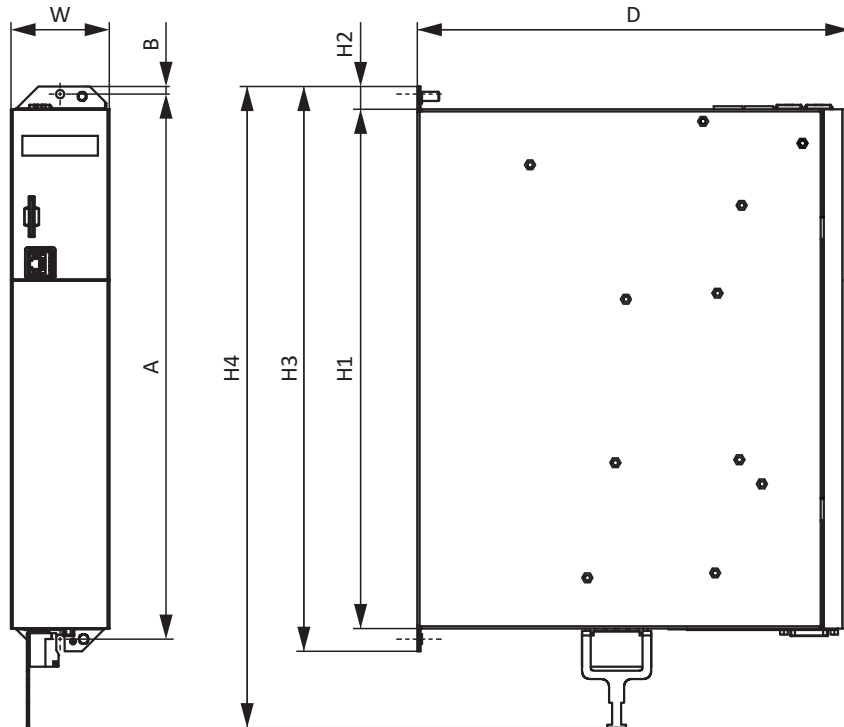

Fig. 2: SC6 dimensional drawing

Dimension			SC6A062	SC6A162	SC6A261
Drive controller	Width	W	45		65
	Depth	D	265		286
	Body height	H1			343
	Fastening clip height	H2			15
	Height incl. fastening clips	H3			373
	Total height incl. shield connection	H4			423
Fastening bores (M5)	Vertical distance	A			360+2
	Vertical distance to the upper edge	B			5

Tab. 25: SC6 dimensions [mm]

Take the additional installation depth of the rear section modules into account when calculating the overall dimensions.

### 3.2.8 Weight

Type	Weight without packaging [g]	Weight with packaging [g]
SC6A062	3600	5200
SC6A162	5300	6700
SC6A261	5200	6400

Tab. 26: SC6 weight [g]

### 3.2.9 Minimum clearances

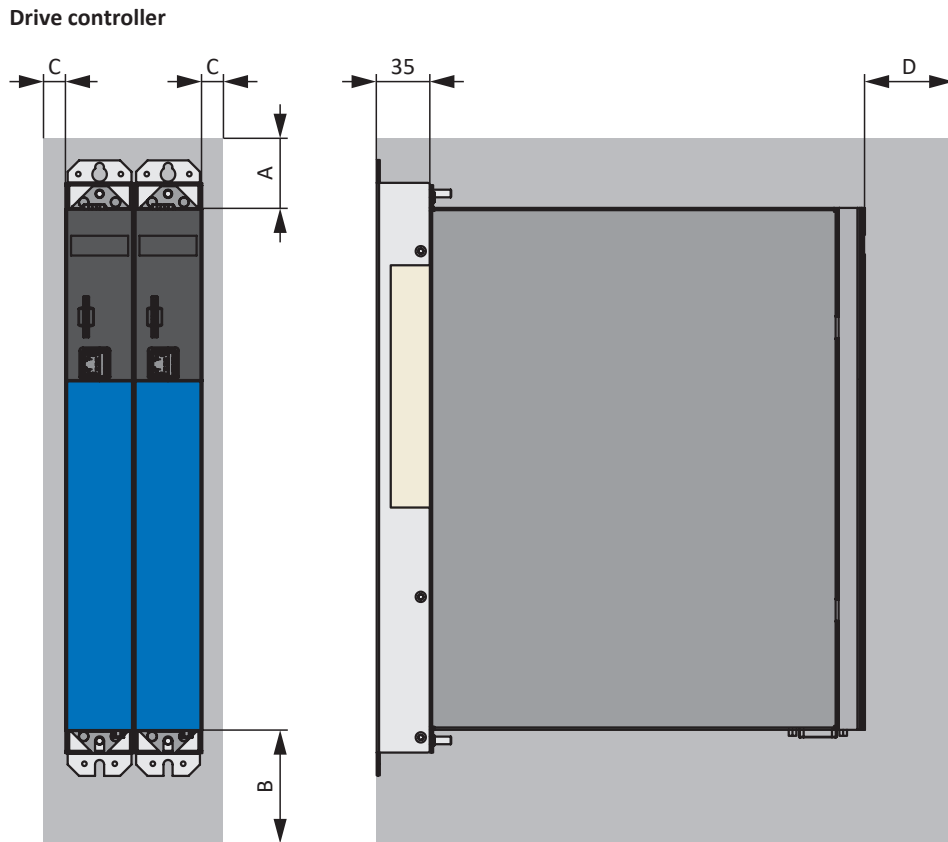

Fig. 3: Minimum clearances

Take into account the additional installation depth of 35 mm for the optional Quick DC-Link DL6B rear section modules.

The dimensions specified in the table relate to the outer edges of the drive controller.

Minimum clearance	A (above)	B (below)	C (on the side)	D (in front)
All sizes	100	200	5	50 <sup>6</sup>

Tab. 27: Minimum clearances [mm]

#### Chokes and filters

Avoid installation below drive controllers or supply modules. For installation in a control cabinet, a distance of approximately 100 mm to other neighboring components is recommended. This distance ensures proper heat dissipation for chokes and filters.

#### Braking resistors

Avoid installation below drive controllers or supply modules. In order for heated air to flow out unimpeded, a minimum clearance of approximately 200 mm must be maintained in relation to neighboring components or walls and approximately 300 mm must be maintained to components above or ceilings.

## 3.3 Drive controller/motor combinations

An explanation of the symbols used for formulas can be found in Chapter [9.1](#).

### IC 410 convection cooling

Type	$K_{EM}$ [V/1000 min <sup>-1</sup> ]	$n_N$ [rpm]	$M_N$ [Nm]	$I_N$ [A]	$M_0$ [Nm]	$I_0$ [A]	Type	$f_{PWM,PU}$ [kHz]	$I_{2N,PU}$ [A]	$I_{2N,PU}/I_0$
<b>EZ2</b>										
EZ203U	40	6000	0.61	1.54	0.69	1.64	SC6A062	4	4.5	2.7
EZ203U	40	6000	0.61	1.54	0.69	1.64	SC6A062	8	4	2.4
<b>EZ3</b>										
EZ301U	40	3000	0.93	1.99	0.95	2.02	SC6A062	4	4.5	2.2
EZ301U	40	3000	0.93	1.99	0.95	2.02	SC6A062	8	4	2.0
EZ301U	40	6000	0.89	1.93	0.95	2.02	SC6A062	4	4.5	2.2
EZ301U	40	6000	0.89	1.93	0.95	2.02	SC6A062	8	4	2.0
EZ302U	86	3000	1.59	1.60	1.68	1.67	SC6A062	4	4.5	2.7
EZ302U	86	3000	1.59	1.60	1.68	1.67	SC6A062	8	4	2.4
EZ302U	42	6000	1.50	3.18	1.68	3.48	SC6A062	4	4.5	1.3
EZ302U	42	6000	1.50	3.18	1.68	3.48	SC6A062	8	4	1.2
EZ302U	42	6000	1.50	3.18	1.68	3.48	SC6A162	4	10	2.9
EZ302U	42	6000	1.50	3.18	1.68	3.48	SC6A162	8	9	2.6
EZ303U	109	3000	2.07	1.63	2.19	1.71	SC6A062	4	4.5	2.6
EZ303U	109	3000	2.07	1.63	2.19	1.71	SC6A062	8	4	2.3
EZ303U	55	6000	1.96	3.17	2.25	3.55	SC6A062	4	4.5	1.3
EZ303U	55	6000	1.96	3.17	2.25	3.55	SC6A062	8	4	1.1
EZ303U	55	6000	1.96	3.17	2.25	3.55	SC6A162	4	10	2.8
EZ303U	55	6000	1.96	3.17	2.25	3.55	SC6A162	8	9	2.5
<b>EZ4</b>										
EZ401U	96	3000	2.80	2.74	3.00	2.88	SC6A062	4	4.5	1.6
EZ401U	96	3000	2.80	2.74	3.00	2.88	SC6A062	8	4	1.4
EZ401U	47	6000	2.30	4.56	2.80	5.36	SC6A162	4	10	1.9
EZ401U	47	6000	2.30	4.56	2.80	5.36	SC6A162	8	9	1.7
EZ401U	47	6000	2.30	4.56	2.80	5.36	SC6A261	8	15	2.8
EZ402U	94	3000	4.70	4.40	5.20	4.80	SC6A162	4	10	2.1
EZ402U	94	3000	4.70	4.40	5.20	4.80	SC6A162	8	9	1.9
EZ402U	60	6000	3.50	5.65	4.90	7.43	SC6A162	4	10	1.4
EZ402U	60	6000	3.50	5.65	4.90	7.43	SC6A162	8	9	1.2
EZ402U	60	6000	3.50	5.65	4.90	7.43	SC6A261	4	19	2.6
EZ402U	60	6000	3.50	5.65	4.90	7.43	SC6A261	8	15	2.0
EZ404U	116	3000	6.90	5.80	8.60	6.60	SC6A162	4	10	1.5
EZ404U	116	3000	6.90	5.80	8.60	6.60	SC6A162	8	9	1.4
EZ404U	116	3000	6.90	5.80	8.60	6.60	SC6A261	4	19	2.9
EZ404U	116	3000	6.90	5.80	8.60	6.60	SC6A261	8	15	2.3
EZ404U	78	6000	5.80	7.18	8.40	9.78	SC6A162	4	10	1.0
EZ404U	78	6000	5.80	7.18	8.40	9.78	SC6A261	4	19	1.9
EZ404U	78	6000	5.80	7.18	8.40	9.78	SC6A261	8	15	1.5
<b>EZ5</b>										
EZ501U	97	3000	4.30	3.74	4.70	4.00	SC6A062	4	4.5	1.1
EZ501U	97	3000	4.30	3.74	4.70	4.00	SC6A062	8	4	1.0
EZ501U	97	3000	4.30	3.74	4.70	4.00	SC6A162	4	10	2.5
EZ501U	97	3000	4.30	3.74	4.70	4.00	SC6A162	8	9	2.3
EZ501U	68	6000	3.40	4.77	4.40	5.80	SC6A162	4	10	1.7
EZ501U	68	6000	3.40	4.77	4.40	5.80	SC6A162	8	9	1.6
EZ501U	68	6000	3.40	4.77	4.40	5.80	SC6A261	8	15	2.6
EZ502U	121	3000	7.40	5.46	8.00	5.76	SC6A162	4	10	1.7
EZ502U	121	3000	7.40	5.46	8.00	5.76	SC6A162	8	9	1.6
EZ502U	121	3000	7.40	5.46	8.00	5.76	SC6A261	8	15	2.6
EZ502U	72	6000	5.20	7.35	7.80	9.80	SC6A162	4	10	1.0
EZ502U	72	6000	5.20	7.35	7.80	9.80	SC6A261	4	19	1.9
EZ502U	72	6000	5.20	7.35	7.80	9.80	SC6A261	8	15	1.5
EZ503U	119	3000	9.70	6.90	11.1	7.67	SC6A162	4	10	1.3
EZ503U	119	3000	9.70	6.90	11.1	7.67	SC6A162	8	9	1.2
EZ503U	119	3000	9.70	6.90	11.1	7.67	SC6A261	4	19	2.5
EZ503U	119	3000	9.70	6.90	11.1	7.67	SC6A261	8	15	2.0
EZ503U	84	6000	6.20	7.64	10.6	11.6	SC6A261	4	19	1.6
EZ503U	84	6000	6.20	7.64	10.6	11.6	SC6A261	8	15	1.3
EZ505U	141	3000	13.5	8.80	16.0	10.0	SC6A162	4	10	1.0

3.3 Drive controller/motor combinations 3 SC6 drive controllers

Type	$K_{EM}$ [V/1000 min <sup>-1</sup> ]	$n_N$ [rpm]	$M_N$ [Nm]	$I_N$ [A]	$M_0$ [Nm]	$I_0$ [A]	Type	$f_{PWM,PU}$ [kHz]	$I_{2N,PU}$ [A]	$I_{2N,PU}/I_0$
<b>EZ5</b>										
EZ505U	141	3000	13.5	8.80	16.0	10.0	SC6A261	4	19	1.9
EZ505U	141	3000	13.5	8.80	16.0	10.0	SC6A261	8	15	1.5
EZ505U	103	4500	9.50	8.94	15.3	13.4	SC6A261	4	19	1.4
EZ505U	103	4500	9.50	8.94	15.3	13.4	SC6A261	8	15	1.1
<b>EZ7</b>										
EZ701U	95	3000	7.40	7.20	8.30	8.00	SC6A162	4	10	1.3
EZ701U	95	3000	7.40	7.20	8.30	8.00	SC6A162	8	9	1.1
EZ701U	95	3000	7.40	7.20	8.30	8.00	SC6A261	4	19	2.4
EZ701U	95	3000	7.40	7.20	8.30	8.00	SC6A261	8	15	1.9
EZ701U	76	6000	5.20	6.68	7.90	9.38	SC6A162	4	10	1.1
EZ701U	76	6000	5.20	6.68	7.90	9.38	SC6A261	4	19	2.0
EZ701U	76	6000	5.20	6.68	7.90	9.38	SC6A261	8	15	1.6
EZ702U	133	3000	12.0	8.20	14.4	9.60	SC6A162	4	10	1.0
EZ702U	133	3000	12.0	8.20	14.4	9.60	SC6A261	4	19	2.0
EZ702U	133	3000	12.0	8.20	14.4	9.60	SC6A261	8	15	1.6
EZ702U	82	6000	7.20	8.96	14.3	16.5	SC6A261	4	19	1.2
EZ703U	122	3000	16.5	11.4	20.8	14.0	SC6A261	4	19	1.4
EZ703U	122	3000	16.5	11.4	20.8	14.0	SC6A261	8	15	1.1
EZ703U	99	4500	12.1	11.5	20.0	17.8	SC6A261	4	19	1.1
<b>EZ8</b>										
EZ813U	239	2000	39.0	14.9	43.7	16.5	SC6A261	4	19	1.2

## IC 416 forced ventilation

Type	$K_{EM}$ [V/1000 min <sup>-1</sup> ]	$n_N$ [rpm]	$M_N$ [Nm]	$I_N$ [A]	$M_0$ [Nm]	$I_0$ [A]	Type	$f_{PWM,PU}$ [kHz]	$I_{2N,PU}$ [A]	$I_{2N,PU}/I_0$
<b>EZ4</b>										
EZ401B	96	3000	3.40	3.40	3.70	3.60	SC6A062	4	4.5	1.3
EZ401B	96	3000	3.40	3.40	3.70	3.60	SC6A062	8	4	1.1
EZ401B	96	3000	3.40	3.40	3.70	3.60	SC6A162	4	10	2.8
EZ401B	96	3000	3.40	3.40	3.70	3.60	SC6A162	8	9	2.5
EZ401B	47	6000	2.90	5.62	3.50	6.83	SC6A162	4	10	1.5
EZ401B	47	6000	2.90	5.62	3.50	6.83	SC6A162	8	9	1.3
EZ401B	47	6000	2.90	5.62	3.50	6.83	SC6A261	4	19	2.8
EZ401B	47	6000	2.90	5.62	3.50	6.83	SC6A261	8	15	2.2
EZ402B	94	3000	5.90	5.50	6.30	5.80	SC6A162	4	10	1.7
EZ402B	94	3000	5.90	5.50	6.30	5.80	SC6A162	8	9	1.6
EZ402B	94	3000	5.90	5.50	6.30	5.80	SC6A261	8	15	2.6
EZ402B	60	6000	5.10	7.88	6.40	9.34	SC6A162	4	10	1.1
EZ402B	60	6000	5.10	7.88	6.40	9.34	SC6A261	4	19	2.0
EZ402B	60	6000	5.10	7.88	6.40	9.34	SC6A261	8	15	1.6
EZ404B	116	3000	10.2	8.20	11.2	8.70	SC6A162	4	10	1.2
EZ404B	116	3000	10.2	8.20	11.2	8.70	SC6A162	8	9	1.0
EZ404B	116	3000	10.2	8.20	11.2	8.70	SC6A261	4	19	2.2
EZ404B	116	3000	10.2	8.20	11.2	8.70	SC6A261	8	15	1.7
EZ404B	78	6000	8.00	9.98	10.5	12.0	SC6A261	4	19	1.6
EZ404B	78	6000	8.00	9.98	10.5	12.0	SC6A261	8	15	1.3
<b>EZ5</b>										
EZ501B	97	3000	5.40	4.70	5.80	5.00	SC6A162	4	10	2.0
EZ501B	97	3000	5.40	4.70	5.80	5.00	SC6A162	8	9	1.8
EZ501B	97	3000	5.40	4.70	5.80	5.00	SC6A261	8	15	3.0
EZ501B	68	6000	4.50	6.70	5.70	7.50	SC6A162	4	10	1.3
EZ501B	68	6000	4.50	6.70	5.70	7.50	SC6A162	8	9	1.2
EZ501B	68	6000	4.50	6.70	5.70	7.50	SC6A261	4	19	2.5
EZ501B	68	6000	4.50	6.70	5.70	7.50	SC6A261	8	15	2.0
EZ502B	121	3000	10.3	7.80	11.2	8.16	SC6A162	4	10	1.2
EZ502B	121	3000	10.3	7.80	11.2	8.16	SC6A162	8	9	1.1
EZ502B	121	3000	10.3	7.80	11.2	8.16	SC6A261	4	19	2.3
EZ502B	121	3000	10.3	7.80	11.2	8.16	SC6A261	8	15	1.8
EZ502B	72	6000	8.20	11.4	10.5	13.4	SC6A261	4	19	1.4
EZ502B	72	6000	8.20	11.4	10.5	13.4	SC6A261	8	15	1.1
EZ503B	119	3000	14.4	10.9	15.9	11.8	SC6A261	4	19	1.6
EZ503B	119	3000	14.4	10.9	15.9	11.8	SC6A261	8	15	1.3
EZ503B	84	6000	10.4	13.5	14.8	15.9	SC6A261	4	19	1.2
EZ505B	141	3000	20.2	13.7	23.4	14.7	SC6A261	4	19	1.3
EZ505B	141	3000	20.2	13.7	23.4	14.7	SC6A261	8	15	1.0
<b>EZ7</b>										
EZ701B	95	3000	9.70	9.50	10.5	10.0	SC6A162	4	10	1.0
EZ701B	95	3000	9.70	9.50	10.5	10.0	SC6A261	4	19	1.9
EZ701B	95	3000	9.70	9.50	10.5	10.0	SC6A261	8	15	1.5
EZ701B	76	6000	7.50	10.6	10.2	12.4	SC6A261	4	19	1.5
EZ701B	76	6000	7.50	10.6	10.2	12.4	SC6A261	8	15	1.2
EZ702B	133	3000	16.6	11.8	19.3	12.9	SC6A261	4	19	1.5
EZ702B	133	3000	16.6	11.8	19.3	12.9	SC6A261	8	15	1.2

## 3.4 Accessories

You can find information about the available accessories in the following chapters.

### 3.4.1 Safety technology

#### Information

The drive controller is delivered in the standard design without safety technology (option SZ6). If you want a drive controller with integrated safety technology, you must order it together with the drive controller. The safety modules are an integrated part of the drive controllers and must not be modified.

#### SZ6 option – Without safety technology

ID No. 56660

Design without safety technology.

#### SX6 safety module – Extended safety technology using FSoE

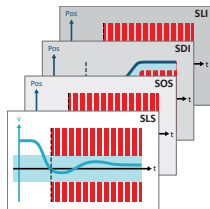

ID No. 5050185

Optional accessory for use in safety-related applications up to PL e, SIL 3 in accordance with EN ISO 13849-1 and EN 61800-5-2. In addition to the basic Safe Torque Off (STO) safety function, SX6 provides other safety functions specified in EN 61800-5-2. In addition to the safe stop functions Safe Stop 1 (SS1) and Safe Stop 2 (SS2), these also include Safely-Limited Speed (SLS), Safe Brake Control (SBC), Safe Brake Test (SBT), Safe Direction (SDI) and Safely-Limited Increment (SLI). Connection to the higher-level safety circuit using Fail Safe over EtherCAT (FSoE).

#### SR6 safety module – STO using terminals



ID No. 56661

Optional accessory for the use of the Safe Torque Off safety function (STO) in safety-relevant applications (PL e, SIL 3) in accordance with EN ISO 13849-1 and EN 61800-5-2. Connection to a higher-level safety circuit via terminal X12.

#### SY6 safety module – STO and SS1 using FSoE



ID No. 56662

Optional accessory for the use of the Safe Torque Off (STO) and Safe Stop 1 (SS1) safety functions in safety-relevant applications (PL e, SIL 3) in accordance with EN ISO 13849-1 and EN 61800-5-2. Connection to the higher-level safety circuit using Fail Safe over EtherCAT (FSoE).

#### SU6 safety module – STO and SS1 using PROFI-safe



ID No. 56696

Optional accessory for the use of the Safe Torque Off (STO) and Safe Stop 1 (SS1) safety functions in safety-relevant applications (PL e, SIL 3) in accordance with EN ISO 13849-1 and EN 61800-5-2. Connection to a higher-level safety circuit via PROFINET (PROFI-safe).

## 3.4.2 Communication

The drive controller has two interfaces for the EtherCAT or PROFINET connection on the top of the device as well as an Ethernet service interface on the front of the device. Cables for the connection are available separately.

### EtherCAT or PROFINET



Specify the desired fieldbus system when placing your order for the base device, since fieldbus communication is defined by the firmware.



### EtherCAT cables



Ethernet patch cable, CAT5e, yellow.  
The following designs are available:  
ID no. 49313: length approx. 0.25 m.  
ID no. 49314: length approx. 0.5 m.

### PC connecting cable



ID No. 49857  
Cable for connecting the X9 service interface to the PC, CAT5e, blue, length: 5 m.

### USB 2.0 Ethernet adapter



ID No. 49940  
Adapter for connecting Ethernet to a USB port.

## 3.4.3 Terminal set

For connection, you need the fitting terminal set for each SC6 drive controller.

### Terminal set for drive controllers without SR6 safety module (STO using terminals)

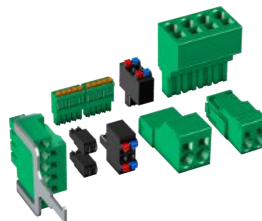

(Fig. similar)

The following designs are available:  
ID No. 138652  
Terminal set for SC6A062Z/U/Y/X. Contents: 13 terminals.  
ID No. 138653  
Terminal set for SC6A162Z/U/Y/X. Contents: 13 terminals.  
ID No. 138654  
Terminal set for SC6A261Z/U/Y/X. Contents: 11 terminals.

### Terminal set for drive controllers with SR6 safety module (STO using terminals)

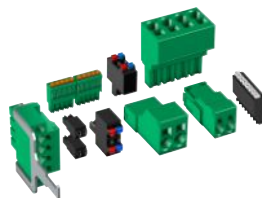

(Fig. similar)

The following designs are available:  
ID No. 138680  
Terminal set for SC6A062R. Contents: 14 terminals.  
ID No. 138681  
Terminal set for SC6A162R. Contents: 14 terminals.  
ID No. 138682  
Terminal set for SC6A261R. Contents: 12 terminals.

### 3.4.4 DC link connection

If you want to connect SC6 drive controllers in the DC link group, you will need Quick DC-Link modules of type DL6B.

You receive the DL6B rear section modules in different designs for a horizontal connection, suitable for the size of the drive controller.

The quick fastening clamps for attaching the copper rails and an insulation connection piece are contained in the scope of delivery. The copper rails are not included in the scope of delivery. These must have a cross-section of 5 x 12 mm. Insulation end sections for the left and right termination of the device group as well as covers for the rear section modules are available separately. The covers protect rear section modules installed in the control cabinet that are only later built over with drive controllers, for example as part of a retrofit.

#### Quick DC-Link DL6B – rear section module for drive controller



The following designs are available:

DL6B10

ID No. 56655

Rear section module for size 0 drive controller:

SC6A062

DL6B11

ID No. 56656

Rear section module for size 1 or 2 drive controller:

SC6A162 and SC6A261

#### Quick DC-Link DL6B – insulation end section

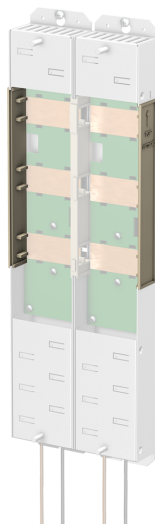

ID No. 56659

Insulation end sections for the left and right termination of the group, 2 pcs.

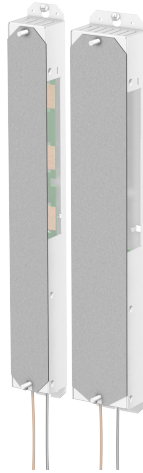
**Quick DC-Link DL6B – cover**

The following designs are available:

QDL6C10

Id. No. 5050128

Cover for rear section module DL6B10,

Dimensions: 373 × 45 × 1 mm

QDL6C11

Id. No. 5050129

Cover for rear section module DL6B11,

Dimensions: 373 × 64 × 1 mm

### 3.4.5 Braking resistor

In addition to drive controllers, STOBBER offers the following braking resistors described below in various sizes and performance classes. For the selection, note the minimum permitted braking resistors specified in the technical data of the individual drive controller types.

#### 3.4.5.1 Tubular fixed resistor FZMU, FZZMU

Type	FZMU 400×65	FZZMU 400×65
ID No.	49010	53895
SC6A062	X	—
SC6A162	(X)	X
SC6A261	(X)	X

Tab. 28: Assignment of FZMU, FZZMU braking resistor – SC6 drive controller

X	Recommended
(X)	Possible
—	Not possible

#### Properties

Technical data	FZMU 400×65	FZZMU 400×65
ID No.	49010	53895
Type	Tubular fixed resistor	Tubular fixed resistor
Resistance [Ω]	100 ±10%	47 ±10%
Thermal drift	±10%	±10%
Power [W]	600	1200
Therm. time const. $\tau_{th}$ [s]	40	40
Pulse power for < 1 s [kW]	18	36
$U_{max}$ [V]	848	848
Weight without packaging [g]	2200	4170
Protection class	IP20	IP20
Marks and test symbols	cURus, CE, UKCA	cURus, CE, UKCA

Tab. 29: FZMU, FZZMU technical data

Dimensions

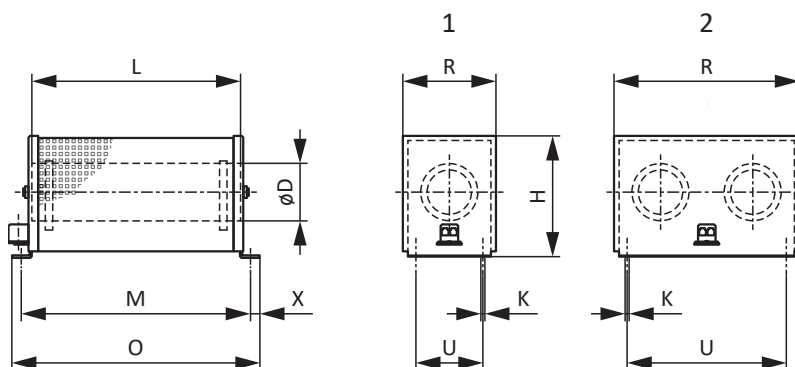

Fig. 4: FZMU (1), FZZMU (2) dimensional drawing

Dimension	FZMU 400×65	FZZMU 400×65
ID No.	49010	53895
L x D	400 × 65	400 × 65
H	120	120
K	6.5 × 12	6.5 × 12
M	430	426
O	485	485
R	92	185
U	64	150
X	10	10

Tab. 30: FZMU, FZZMU dimensions [mm]

3.4.5.2 GVADU, GBADU flat resistor

Type	GVADU 210×20	GBADU 265×30	GBADU 335×30
ID No.	55441	55442	55443
SC6A062	X	X	—
SC6A162	(X)	(X)	X
SC6A261	(X)	(X)	X

Tab. 31: Assignment of GVADU, GBADU braking resistor – SC6 drive controller

- X Recommended
- (X) Possible
- Not possible

Properties

Technical data	GVADU 210×20	GBADU 265×30	GBADU 335×30
ID No.	55441	55442	55443
Type	Flat resistor		
Resistance [Ω]	100 ±10%	100 ±10%	47 ±10%
Thermal drift	±10%	±10%	±10%
Power [W]	150	300	400
Therm. time const. $\tau_{th}$ [s]	60	60	60
Pulse power for < 1 s [kW]	3.3	6.6	8.8
$U_{max}$ [V]	848	848	848
Cable design	Radox	FEP	FEP
Cable length [mm]	500	1500	1500
Conductor cross-section [AWG]	18/19	14/19	14/19
	(0.82 mm <sup>2</sup> )	(1.9 mm <sup>2</sup> )	(1.9 mm <sup>2</sup> )
Weight without packaging [g]	300	930	1200
Protection class	IP54	IP54	IP54
Marks and test symbols	cURus, CE, UKCA		

Tab. 32: GVADU, GBADU technical data

Dimensions

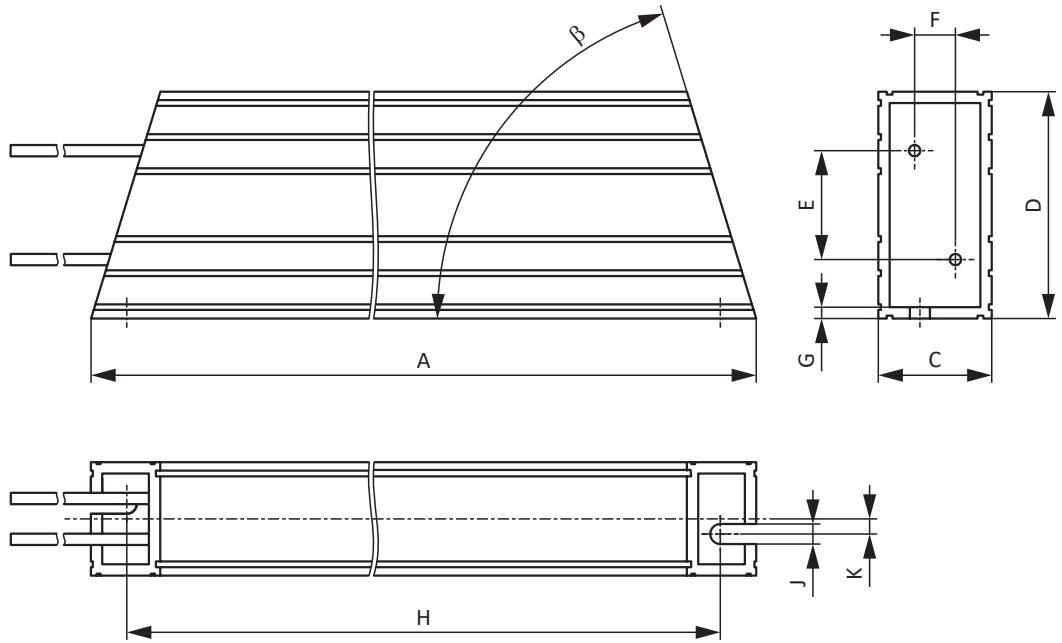

Fig. 5: GVADU, GBADU dimensional drawing

Dimension	GVADU 210×20	GBADU 265×30	GBADU 335×30
ID No.	55441	55442	55443
A	210	265	335
H	192	246	316
C	20	30	30
D	40	60	60
E	18.2	28.8	28.8
F	6.2	10.8	10.8
G	2	3	3
K	2.5	4	4
J	4.3	5.3	5.3
$\beta$	65°	73°	73°

Tab. 33: GVADU, GBADU dimensions [mm]

## 3.4.6 Choke

Technical specifications for suitable chokes can be found in the following chapters.

### 3.4.6.1 TEP output choke

Output chokes are required for connecting size 0 to 2 drive controllers to synchronous servo motors or asynchronous motors from a cable length > 50 m in order to reduce interference pulses and protect the drive system. If Lean motors are connected, output chokes must not be used.

#### Information

The following technical data only applies to a rotating magnetic field frequency of 200 Hz. For example, this rotating magnetic field frequency is achieved with a motor with 4 pole pairs and a nominal speed of 3000 rpm. Always observe the specified derating for higher rotating magnetic field frequencies. Also observe the relationship with the clock frequency.

#### Properties

Technical data	TEP3720-0ES41	TEP3820-0CS41	TEP4020-0RS41
ID No.	53188	53189	53190
Voltage range	3 × 0 to 480 V <sub>AC</sub>		
Frequency range	0 – 200 Hz		
Nominal current I <sub>N,MF</sub> at 4 kHz	4 A	17.5 A	38 A
Nominal current I <sub>N,MF</sub> at 8 kHz	3.3 A	15.2 A	30.4 A
Max. permitted motor cable length with output choke	100 m		
Max. surrounding temperature $\vartheta_{amb,max}$	40 °C		
Protection class	IP00		
Winding losses	11 W	29 W	61 W
Iron losses	25 W	16 W	33 W
Connection	Screw terminal		
Max. conductor cross-section	10 mm <sup>2</sup>		
UL Recognized	Yes		
Component (CAN; USA)			
Marks and test symbols	cURus, CE		

Tab. 34: TEP technical data

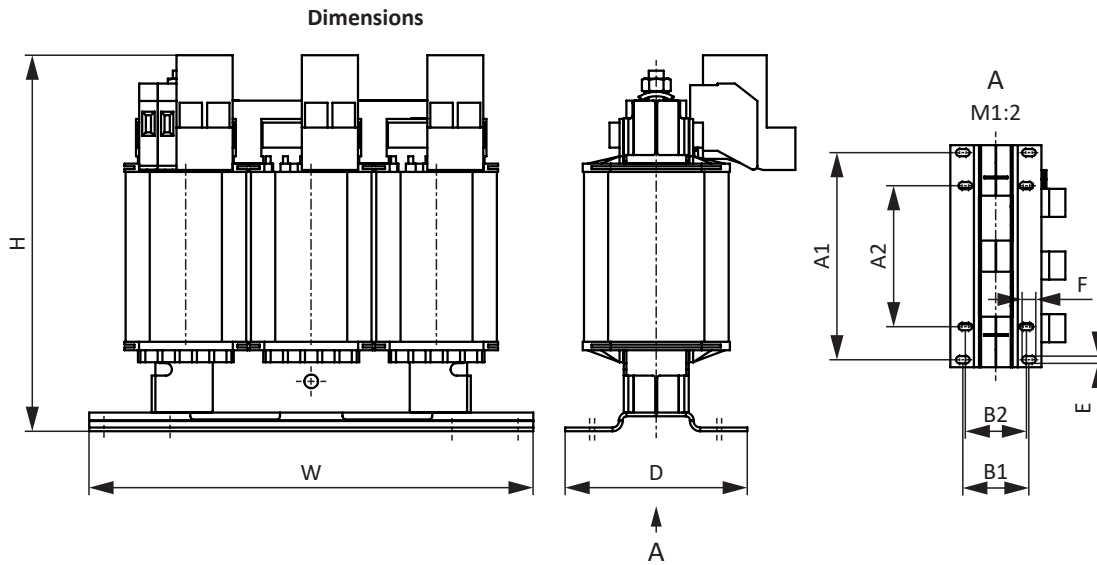

Fig. 6: TEP dimensional drawing

Dimension	TEP3720-0ES41	TEP3820-0CS41	TEP4020-0RS41
Height H [mm]	Max. 150	Max. 152	Max. 172
Width W [mm]	178	178	219
Depth D [mm]	73	88	119
Vertical distance – A1 fastening bores [mm]	166	166	201
Vertical distance – A2 fastening bores [mm]	113	113	136
Horizontal distance – B1 fastening bores [mm]	53	68	89
Horizontal distance – B2 fastening bores [mm]	49	64	76
Drill holes – Depth E [mm]	5.8	5.8	7
Drill holes – Width F [mm]	11	11	13
Screw connection – M	M5	M5	M6
Weight without packaging [g]	2900	5900	8800

Tab. 35: TEP dimensions and weight

### 3.4.7 HTL-to-TTL adapter

#### HT6 HTL-to-TTL adapter



ID No. 56665

Adapters for SC6 and SI6 series drive controllers for level conversion from HTL signals to TTL signals.

It is used to connect an HTL differential incremental encoder to terminal X4 of the drive controller.

## 3.5 Further information

### 3.5.1 Directives and standards

The following European directives and standards are relevant to the drive controllers:

- Directive 2006/42/EC – Machinery Directive
- Directive 2014/30/EU – EMC Directive
- Directive 2011/65/EU – RoHS Directive
- Directive 2009/125/EC – Ecodesign Directive
- EN IEC 61800-3:2018
- EN 61800-5-1:2007 + A1:2017
- EN 61800-5-2:2017
- EN IEC 63000:2018
- EN ISO 13849-1:2015

### 3.5.2 Marks and test symbols

The following marks and test symbols are mentioned in the technical data.



#### RoHS lead-free mark

Marking in accordance with RoHS directive 2011-65-EU.



#### CE mark

Manufacturer's self declaration: The product meets the requirements of EU directives.



#### UKCA test symbol

Manufacturer's self declaration: The product meets the requirements of UK directives.



#### UL test symbol (cULus)

This product is listed by UL for the United States and Canada. Representative samples of this product have been evaluated by UL and meet the requirements of applicable standards.



#### UL recognized component mark (cURus)

This component or material is recognized by UL for the US and Canada. Representative samples of this product have been evaluated by UL and meet applicable requirements.

### 3.5.3 Additional documentation

Additional documentation related to the product can be found at

<http://www.stoeber.de/en/downloads/>

Enter the ID of the documentation in the Search term field.

Documentation	ID
Manual for SC6 drive controllers	442790

## 4 SI6 drive controllers

### Table of contents

4.1	Overview .....	74
4.1.1	Features.....	75
4.1.2	Software components .....	76
4.1.3	Operating motors, encoders and brakes.....	77
4.1.4	Application training.....	77
4.2	Technical data .....	78
4.2.1	General technical data .....	78
4.2.2	Drive controllers.....	79
4.2.3	Supply module.....	87
4.2.4	DC link connection.....	92
4.2.5	Minimum clearances.....	96
4.3	Drive controller/motor combinations.....	98
4.4	Accessories .....	103
4.4.1	Safety technology.....	103
4.4.2	Communication .....	104
4.4.3	Terminal set.....	105
4.4.4	DC link connection.....	106
4.4.5	Braking resistor .....	107
4.4.6	Choke .....	112
4.4.7	HTL-to-TTL adapter.....	115
4.5	Further information .....	116
4.5.1	Directives and standards .....	116
4.5.2	Marks and test symbols .....	116
4.5.3	Additional documentation .....	116



## 4 Drive controllers

# SI6

### 4.1 Overview

The slim one for multi-axis drive systems

#### Features

- Single or double-axis controller with a nominal output current up to 50 A and 250% overload capacity
- Supply modules up to 50 kW nominal power
- Control of rotary synchronous servo motors and asynchronous motors
- Sensorless position control of Lean motors
- Control of linear and torque motors
- One Cable Solution EnDat 3
- Electronic motor nameplate via EnDat encoder interfaces
- Integrated EtherCAT or PROFINET communication
- STO safety technology using terminals or STO and SS1 using FSoE or PROFIsafe: SIL 3, PL e (Cat. 4)
- Extended safety technology (SS1, SS2, SLS, SBC, SBT...) using FSoE
- Integrated brake control
- Energy supply over DC link connection
- Single-ended nominal power consumption on double-axis controllers for operation of motors with different power
- Variable feed-in power using supply modules that can be connected in parallel
- Available EPLAN macros in the EPLAN Data Portal

## 4.1.1 Features

The multi-axis drive system is designed for multi-axis applications and consists of the SI6 drive controller and PS6 supply module in combination. The most striking feature is its extremely compact design! Each SI6 is connected to the central PS6 supply module. Additional fuses and cabling for each individual axis are not required. They thus reduce material and operating costs. Matching Quick DC-Link modules handle the energy supply for the drive controllers in the group. The SI6 drive controller is available in four sizes as a single or double-axis controller with a nominal output current of up to 50 A. The PS6 supply module is available in three sizes with a nominal output power of 10 kW to 50 kW.

For STOBBER synchronous servo motors, we recommended operation with the EnDat 2.2 digital encoder or as a One Cable Solution with EnDat 3. These encoder systems make it possible to attain the highest control quality. It is possible to perform motor parameterization automatically from the electronic motor nameplate.



*Drive control in multi-axis drive systems with SI6 and PS6*

### Dimension capacities precisely

4 axes? 16? Or even 97? A single SI6 drive controller can control up to two axes. Thanks to the multi-axis drive system, the number of motors or axes to be controlled can be scaled without limit. If required, SI6 drive controllers can be combined with stand-alone units from the STOBBER SC6 or SD6 series. For the general energy supply, the drive controllers from the SI6, SC6 and SD6 series can be connected to each other using Quick DC-Link modules.

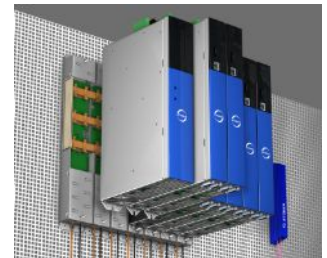

### Tailored energy usage

The SI6 drive controllers are connected to a central supply module. There is no need for decentralized supply modules or fuses and cabling for each axis. When using double-axis modules, the unused power reserves of one axis can be used for the second axis. A significant reduction in space and cost!

### Precise dynamics

The drive controller provides acceleration that is literally as fast as lightning. For example, in conjunction with the STOBBER EZ401 synchronous servo motor: from 0 to 3000 rpm in 10 ms.

### Easy connection, quick and safe parameterization

The One Cable Solution (OCS) from STOBBER combines power and encoder communication in a single hybrid cable – for minimal cabling and easy installation.

The electronic motor nameplate is automatically transmitted via the digital EnDat 3 interface. The drive controller detects all the motor data automatically – the parameterization process is fast, reliable and error-free.

The optimized hybrid cable offers maximum signal quality and system reliability.

Ready-to-connect power and encoder cables with an EnDat 2.2 interface and electronic nameplate function are available as alternatives. Both variants ensure optimal coordination of the interaction between the motor and drive controller – for efficient and reliable commissioning.

**Play it safe with STOBER****Integrated safety**

STOBER drive controllers have safety functions such as Safe Torque Off (STO) and Safe Stop 1 (SS1) – which can be controlled either conventionally via terminals, or via the safe communication standards PROFIsafe (PROFINET) and Fail Safe over EtherCAT (FSoE). The fully electronic design is fast and free of wear. Additional cyclical function tests are no longer necessary. This increases availability and reduces the amount of testing required during operation.

**Extended safety**

For stricter requirements, STOBER offers optional safety functions up to SIL 3, PL e (category 4). In addition to STO, which can be activated for each axis individually in multi-axis systems, extended functions such as Safely Limited Speed (SLS), Safe Operating Stop (SOS), Safe Brake Control (SBC) and Safe Brake Test (SBT) are also available. Optimized monitoring mechanisms ensure short reaction times, minimum safety distances and increased system availability – for productive safety at the highest level.

**Robust and resilient**

The drive controllers boast a stable, durable design. The housing is made from high-quality sheet steel for reliable shielding, mechanical strength and optimum heat dissipation – even under demanding operating conditions. Inside, powerful computing units, carefully selected components and precision manufacturing ensure reliable operation over the long term.

An SD card slot is available on the front panel for removable data storage. An SD card can be used for quick series commissioning by copying, or for easy device replacement in the event of servicing. The removable data storage can also be used as a medium for storing additional project data and documentation.

## 4.1.2 Software components

**Project configuration and commissioning**

The DriveControlSuite project configuration and commissioning software has all the functions for the efficient use of drive controllers in single-axis and multi-axis applications. The program guides you step by step through the complete project configuration and parameterization process using wizards.

**Open communication**

The Ethernet-based EtherCAT and PROFINET fieldbus systems are available in the drive controller.

**Applications**

A controller-based application is recommended for the central motion control of complex machines.

With the controller-based operating modes of the CiA 402 application (csp, csv, cst, ip) or controller-based application class 4 of the PROFIdrive application, you can implement applications with synchronized, cyclic set value specification by a motion controller. In addition, the drive controllers can also independently handle motion tasks, such as referencing and jogging during commissioning. Standard telegrams 3 and 5 as well as telegram 105 are available for controller-based motion control according to PROFIdrive in application class 4. Based on these telegrams, the drive controllers can be used with the PositioningAxis, SynchronousAxis, OutputCam and Kinematics technology objects from TIA Portal.

The Drive Based drive-based applications, the drive-based operating modes of the CiA 402 application (pp, vl, pv, pt) and drive-based application classes 1 and 3 of the PROFIdrive application are also available.

Furthermore, programming based on IEC 61131-3 with CFC can be used to create new applications or expand existing ones.

### 4.1.3 Operating motors, encoders and brakes

You can use the drive controller to operate Lean motors of the LM series, synchronous servo motors (such as those of the EZ series), asynchronous motors, linear motors or torque motors.

Evaluation options for feedback are available on the X4 connection for the following encoders:

- EnDat 2.1/2.2 digital encoders
- SSI encoders
- Differential TTL and differential HTL incremental encoders (HTL via HT6 adapter)
- Resolver
- EnDat 3 or HIPERFACE DSL encoder (with One Cable Solution design)

In addition, evaluation options for the following encoders are available on the X101 and X103 connection:

- Single-ended HTL incremental encoders
- Single-ended HTL pulse/direction interface

All device types of the drive controller have connections for PTC thermistors and can control a 24 V<sub>DC</sub> brake as standard.

### 4.1.4 Application training

STOBER offers a multi-level training program that is essentially focused on the drive controller.

#### G6 Basic

Training content: System overview, installation and commissioning of the drive controller. Use of option modules. Parameterization, commissioning and diagnostics using the commissioning software. Remote maintenance. Basics of controller optimization. Configuration of the drive train. Integrated software functions. Software applications. Connection to a higher-level controller. Basics of safety technology. Practical exercises on training topics.

Software used: DriveControlSuite.

#### G6 Customized

Training content: Special knowledge for regulating, control and safety technology. Practical exercises on training topics.

## 4.2 Technical data

Technical data for the drive controllers, supply modules and accessories can be found in the following chapters.

### 4.2.1 General technical data

The following specifications apply equally to the SI6 drive controller and the PS6 supply module.

Device features	
Protection class of the device	IP20
Protection class of the installation space	At least IP54
Protection class	Protection class I in accordance with EN 61140
Radio interference suppression	Integrated line filter in accordance with EN 61800-3, interference emission class C3
Overvoltage category	III in accordance with EN 61800-5-1
Marks and test symbols	CE, cULus, RoHS

Tab. 1: Device features

Transport and storage conditions	
Storage/ transport temperature	-20 °C to +70 °C Maximum change: 20 K/h
Relative humidity	Maximum relative humidity 85%, non-condensing
Vibration (transport) in accordance with EN 60068-2-6	5 Hz ≤ f ≤ 9 Hz: 3.5 mm 9 Hz ≤ f ≤ 200 Hz: 10 m/s <sup>2</sup> 200 Hz ≤ f ≤ 500 Hz: 15 m/s <sup>2</sup>
Fall height for free fall <sup>1</sup> Weight < 100 kg in accordance with EN 61800-2 (or IEC 60721-3-2, class 2M4)	0.25 m
Shock testing in accordance with EN 60068-2-27	Pulse shape: Half-sine Acceleration: 5 g Shock duration: 30 ms Number of shocks: 3 per axis

Tab. 2: Transport and storage conditions

Operating conditions	
Surrounding temperature during operation	0 °C to 45 °C with nominal data 45 °C to 55 °C with derating -2.5% / K
Relative humidity	Maximum relative humidity 85%, non-condensing
Installation altitude	0 m to 1000 m above sea level without restrictions 1000 m to 2000 m above sea level with -1.5%/100 m derating
Pollution degree	Pollution degree 2 in accordance with EN 50178
Ventilation	Installed fan
Vibration (operation) in accordance with EN 60068-2-6	5 Hz ≤ f ≤ 9 Hz: 0.35 mm 9 Hz ≤ f ≤ 200 Hz: 1 m/s <sup>2</sup>

Tab. 3: Operating conditions

Discharge times	
Self-discharge of DC link	15 min
Fast discharge of DC link	Thanks to PS6 supply module in combination with a braking resistor: < 1 min

Tab. 4: Discharge times of the DC link circuit

## 4.2.2 Drive controllers

The following chapters contain specifications for the electrical data, dimensions and weight of the drive controller.

### 4.2.2.1 Type designation

SI	6	A	0	6	1	Z
----	---	---	---	---	---	---

Tab. 5: Example code for drive controller type designation

Code	Designation	Design
SI	Series	
6	Generation	Generation 6
A	Version	
0 – 3	Size	
6	Power output stage	Power output stage within the size
1	Axis controller	Single-axis controller
2		Double-axis controller
Z	Safety technology	SZ6: Without safety technology
R		SR6: STO using terminals
U		SU6: STO and SS1 using PROFIsafe
Y		SY6: STO and SS1 using FSoE
X		SX6: Extended safety technology using FSoE

Tab. 6: Meaning of the example code

### 4.2.2.2 Sizes

Type	ID No.	Size	Axis controller
SI6A061	56645	Size 0	Single-axis controller
SI6A062	56646	Size 0	Double-axis controller
SI6A161	56647	Size 1	Single-axis controller
SI6A162	56648	Size 1	Double-axis controller
SI6A261	56649	Size 2	Single-axis controller
SI6A262	56653	Size 2	Double-axis controller
SI6A361	56654	Size 3	Single-axis controller

Tab. 7: Available SI6 types and sizes



SI6 in sizes 0 to 3

Note that the basic device is delivered without terminals. Suitable terminal sets are available separately for each size.

### 4.2.2.3 Electrical data

The electrical data of the available SI6 sizes can be found in the following sections.

An explanation of the symbols used for formulas can be found in Chapter [\[ 9.1 \]](#).

#### 4.2.2.3.1 Control unit

Electrical data	All types
$U_{1CU}$	24 V <sub>DC</sub> , +20%/–15%
$I_{1maxCU}$	1.5 A

Tab. 8: Control unit electrical data

#### 4.2.2.3.2 Power unit: Size 0

Electrical data	SI6A061	SI6A062
$U_{1PU}$	280 – 800 V <sub>DC</sub>	
$f_{2PU}$	0 – 700 Hz	
$U_{2PU}$	0 – max. $\frac{U_{1PU}}{\sqrt{2}}$	
$C_{PU}$	180 μF	270 μF

Tab. 9: SI6 electrical data, size 0

#### Nominal currents up to +45 °C (in the control cabinet)

Electrical data	SI6A061	SI6A062
$f_{PWM,PU}$	4 kHz	
$I_{2N,PU}$	5 A	2 × 5 A
$I_{2maxPU}$	210% for 2 s; 150% for 30 s	

Tab. 10: SI6 electrical data, size 0, for 4 kHz clock frequency

Electrical data	SI6A061	SI6A062
$f_{PWM,PU}$	8 kHz	
$I_{2N,PU}$	4.5 A	2 × 4.5 A
$I_{2maxPU}$	250% for 2 s; 200% for 5 s	

Tab. 11: SI6 electrical data, size 0, for 8 kHz clock frequency

#### 4.2.2.3.3 Power unit: Size 1

Electrical data	SI6A161	SI6A162
$U_{1PU}$	280 – 800 V <sub>DC</sub>	
$f_{2PU}$	0 – 700 Hz	
$U_{2PU}$	0 – max. $\frac{U_{1PU}}{\sqrt{2}}$	
$C_{PU}$	470 μF	940 μF

Tab. 12: SI6 electrical data, size 1

#### Nominal currents up to +45 °C (in the control cabinet)

Electrical data	SI6A161	SI6A162
$f_{PWM,PU}$	4 kHz	
$I_{2N,PU}$	12 A	2 × 12 A
$I_{2maxPU}$	210% for 2 s; 150% for 30 s	

Tab. 13: SI6 electrical data, size 1, for 4 kHz clock frequency

Electrical data	SI6A161	SI6A162
$f_{PWM,PU}$	8 kHz	
$I_{2N,PU}$	10 A	2 × 10 A
$I_{2maxPU}$	250% for 2 s; 200% for 5 s	

Tab. 14: SI6 electrical data, size 1, for 8 kHz clock frequency

## 4.2.2.3.4 Power unit: Size 2

Electrical data	SI6A261	SI6A262
$U_{1PU}$	280 – 800 V <sub>DC</sub>	
$f_{2PU}$	0 – 700 Hz	
$U_{2PU}$	0 – max. $\frac{U_{1PU}}{\sqrt{2}}$	
$C_{PU}$	940 µF	2250 µF

Tab. 15: SI6 electrical data, size 2

## Nominal currents up to +45 °C (in the control cabinet)

Electrical data	SI6A261	SI6A262
$f_{PWM,PU}$	4 kHz	
$I_{2N,PU}$	22 A	2 × 25 A
$I_{2maxPU}$	210% for 2 s; 150% for 30 s	

Tab. 16: SI6 electrical data, size 2, for 4 kHz clock frequency

Electrical data	SI6A261	SI6A262
$f_{PWM,PU}$	8 kHz	
$I_{2N,PU}$	20 A	2 × 20 A
$I_{2maxPU}$	250% for 2 s; 200% for 5 s	

Tab. 17: SI6 electrical data, size 2, for 8 kHz clock frequency

## 4.2.2.3.5 Power unit: Size 3

Electrical data	SI6A361
$U_{1PU}$	280 – 800 V <sub>DC</sub>
$f_{2PU}$	0 – 700 Hz
$U_{2PU}$	0 – max. $\frac{U_{1PU}}{\sqrt{2}}$
$C_{PU}$	2250 µF

Tab. 18: SI6 electrical data, size 3

## Nominal currents up to +45 °C (in the control cabinet)

Electrical data	SI6A361
$f_{PWM,PU}$	4 kHz
$I_{2N,PU}$	50 A
$I_{2maxPU}$	210% for 2 s; 150% for 30 s

Tab. 19: SI6 electrical data, size 3, for 4 kHz clock frequency

Electrical data	SI6A361
$f_{PWM,PU}$	8 kHz
$I_{2N,PU}$	40 A
$I_{2maxPU}$	250% for 2 s; 200% for 5 s

Tab. 20: SI6 electrical data, size 3, for 8 kHz clock frequency

4.2.2.3.6 Single-ended nominal power consumption on double-axis controllers

Operating two motors on one double-axis controller makes it possible to operate one of the motors with a continuous current above the nominal current of the drive controller if the continuous current of the second connected motor is lower than the nominal current of the drive controller. This enables economical combinations of double-axis controllers and motors.

An explanation of the symbols used for formulas can be found in Chapter [ 9.1].

The nominal output current for axis B can be determined using the following formula if the output current for axis A is known:

Formula 1

$$I_{2PU(B)} = I_{2N,PU} - (I_{2PU(A)} - I_{2N,PU}) \times \frac{3}{5} \quad \text{for} \quad 0 \leq I_{2PU(A)} \leq I_{2N,PU}$$

Formula 2

$$I_{2PU(B)} = I_{2N,PU} - (I_{2PU(A)} - I_{2N,PU}) \times \frac{5}{3} \quad \text{for} \quad I_{2N,PU} \leq I_{2PU(A)} \leq 1,6 \times I_{2N,PU}$$

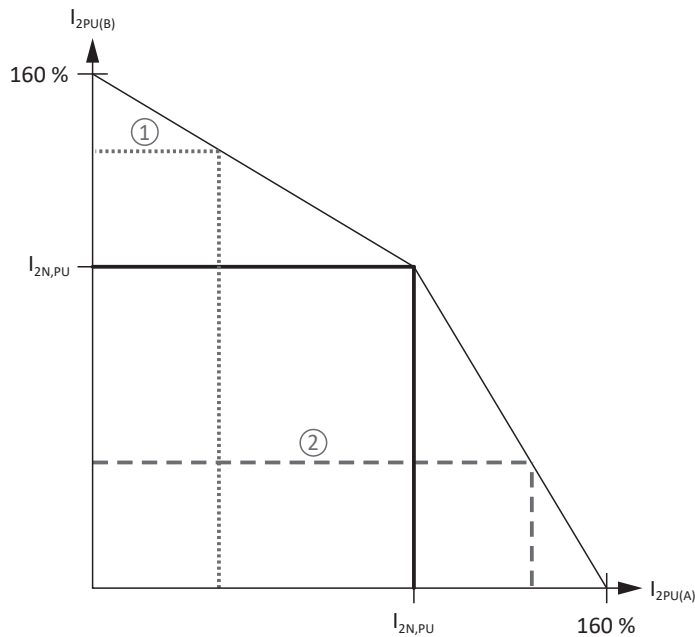

Fig. 1: Asymmetric load on double-axis controllers

Information

Note that the available maximum currents  $I_{2maxPU}$  of the axis controllers are also relative to the nominal output current  $I_{2N,PU}$  for single-ended nominal power consumption.

## 4.2.2.3.7 Power loss data in accordance with EN 61800-9-2

Type	Nominal current $I_{2N,PU}$	Apparent power	Absolute losses $P_{V,CU}^2$	Operating points <sup>3</sup>								IE class <sup>4</sup>	Comparison <sup>5</sup>	
				(0/25)	(0/50)	(0/100)	(50/25)	(50/50)	(50/100)	(90/50)	(90/100)			
				Relative losses										
				[A]	[kVA]	[W]	[%]							
SI6A06x	5	3.5	Max. 10	0.71	0.86	1.33	0.76	0.97	1.61	1.13	2.13	IE2		
SI6A16x	12	8.3	Max. 10	0.55	0.71	1.19	0.59	0.80	1.44	0.94	1.87	IE2		
SI6A261	22	16.6	Max. 10	0.55	0.71	1.19	0.59	0.80	1.44	0.94	1.87	IE2		
SI6A262	25	17.3	Max. 10	0.45	0.62	1.12	0.50	0.74	1.47	0.95	2.12	IE2		
SI6A361	50	34.6	Max. 10	0.45	0.62	1.12	0.50	0.74	1.47	0.95	2.12	IE2		
				Absolute losses $P_V$										
				[A]	[kVA]	[W]	[W]						[%]	
SI6A06x	5	3.5	Max. 10	25	30.2	46.5	26.5	33.8	56.5	39.5	74.4	IE2	24.9	
SI6A16x	12	8.3	Max. 10	45.7	58.7	98.7	49.1	66.3	119.6	78.1	155.4	IE2	26.7	
SI6A261	22	16.6	Max. 10	91.5	117.4	197.3	98.2	132.6	239.2	156.2	310.8	IE2	30.8	
SI6A262	25	17.3	Max. 10	77.9	106.5	193.0	87.1	127.9	254.3	163.8	367.6	IE2	36.4	
SI6A361	50	34.6	Max. 10	155.8	213.1	386.0	174.3	255.8	508.6	327.6	735.2	IE2	39.5	

Tab. 21: Power loss data in accordance with EN 61800-9-2 for one axis of a SI6 drive controller

**General conditions**

The specified losses apply to an axis of a drive controller and take into account the proportionate losses of the PS6 supply module for that axis.

For a group with a total of x axes, multiply the values by the number of axis controllers (x), e.g., x = 4 for 1 × PS6 and 2 × SI6A062.

The power loss data applies to drive controllers without accessories.

The power loss calculation is based on a three-phase supply voltage with 400 V<sub>AC</sub>/50 Hz.

The calculated data includes a supplement of 10% in accordance with EN 61800-9-2.

The power loss specifications refer to a clock frequency of 4 kHz.

The absolute losses for a power unit that is switched off refer to the 24 V<sub>DC</sub> power supply of the control electronics.

## 4.2.2.3.8 Power loss data of accessories

If you intend to order the drive controller with accessory parts, losses increase as follows.

Type	Absolute losses $P_V$ [W]
SR6 safety module	1
SY6 or SU6 safety module	2
SX6 safety module	< 4

Tab. 22: Absolute losses of the accessories

**Information**

Note the absolute power loss of the encoder (usually < 3 W) and of the brake when designing as well.

Loss specifications for other optional accessories can be found in the technical data of the respective accessory part.

<sup>2</sup> Absolute losses for a power unit that is switched off

<sup>3</sup> Operating points for relative motor stator frequency in % and relative torque current in %

<sup>4</sup> IE class in accordance with EN 61800-9-2

<sup>5</sup> Comparison of the losses for the reference related to IE2 in the nominal point (90, 100)

### 4.2.2.4 Cycle times

Possible cycle times can be found in the following table.

Type	Cycle times	Relevant parameters
Application	250 μs, 500 μs, 1 ms, 2 ms, 4 ms, 8 ms	Adjustable in A150
EtherCAT fieldbus, cyclical communication	250 μs, 500 μs, 1 ms, 2 ms, 4 ms, 8 ms	Adjustable in TwinCAT 3 or CODESYS
PROFINET RT fieldbus, cyclical communication	1 ms, 2 ms, 4 ms, 8 ms	Adjustable in the TIA Portal
PROFINET IRT fieldbus, cyclical communication	1 ms, 2 ms, 4 ms	Adjustable in the TIA Portal
Motion core (movement calculation)	250 μs	—
Control cascade	62.5 μs	B24 ≥ 8 kHz and B20 = 48, 64 or 70
	125 μs	B24 = 4 kHz

Tab. 23: Cycle times

<b>Information</b>
--------------------

For Lean motors (control mode B20 = 32: LM - sensorless vector control), only operation at 4 kHz is permitted.

### 4.2.2.5 Derating

When dimensioning the drive controller, observe the derating of the nominal output current as a function of the clock frequency, surrounding temperature and installation altitude. There is no restriction for a surrounding temperature from 0 °C to 45 °C and an installation altitude of 0 m to 1000 m. The details given below apply to values outside these ranges.

#### 4.2.2.5.1 Effect of the clock frequency

Changing the clock frequency  $f_{PWM}$  affects the amount of noise produced by the drive, among other things. However, increasing the clock frequency results in increased losses. During project configuration, define the highest clock frequency and use it to determine the nominal output current  $I_{2N,PU}$  for dimensioning the drive controller.

Type	$I_{2N,PU}$ 4 kHz [A]	$I_{2N,PU}$ 8 kHz [A]	$I_{2N,PU}$ 16 kHz [A]
SI6A061	5	4.5	3.5
SI6A062	2 × 5	2 × 4.5	2 × 3.5
SI6A161	12	10	6
SI6A162	2 × 12	2 × 10	2 × 6
SI6A261	22	20	10
SI6A262	2 × 25	2 × 20	2 × 10
SI6A361	50	40	—

Tab. 24: Nominal output current  $I_{2N,PU}$  dependent on the clock frequency

#### 4.2.2.5.2 Effect of the surrounding temperature

Derating as a function of the surrounding temperature is determined as follows:

- 0 °C to 45 °C: No restrictions ( $D_T = 100\%$ )
- 45 °C to 55 °C: Derating  $-2.5\%/K$

**Example**

The drive controller needs to be operated at 50 °C.

The derating factor  $D_T$  is calculated as follows

$$D_T = 100\% - 5 \times 2.5\% = 87.5\%$$

#### 4.2.2.5.3 Effect of the installation altitude

Derating as a function of the installation altitude is determined as follows:

- 0 m to 1000 m: No restriction ( $D_{IA} = 100\%$ )
- 1000 m to 2000 m: Derating  $-1.5\%/100$  m

##### Example

The drive controller needs to be installed at an altitude of 1500 m above sea level.

The derating factor  $D_{IA}$  is calculated as follows:

$$D_{IA} = 100\% - 5 \times 1.5\% = 92.5\%$$

#### 4.2.2.5.4 Calculating the derating

Follow these steps for the calculation:

1. Determine the highest clock frequency ( $f_{PWM}$ ) that will be used during operation and use it to determine the nominal current  $I_{2N,PU}$ .
2. Determine the derating factors for installation altitude and surrounding temperature.
3. Calculate the reduced nominal current  $I_{2N,PU(red)}$  in accordance with the following formula:

$$I_{2N,PU(red)} = I_{2N,PU} \times D_T \times D_{IA}$$

##### Example

A drive controller of type SI6A061 needs to be operated at a clock frequency of 8 kHz at an altitude of 1500 m above sea level and a surrounding temperature of 50 °C.

The nominal current of the SI6A061 at 8 kHz is 4.5 A. The derating factor  $D_T$  is calculated as follows:

$$D_T = 100\% - 5 \times 2.5\% = 87.5\%$$

The derating factor  $D_{IA}$  is calculated as follows:

$$D_{IA} = 100\% - 5 \times 1.5\% = 92.5\%$$

The output current of importance for the project configuration is:

$$I_{2N,PU(red)} = 4.5 \text{ A} \times 0.875 \times 0.925 = 3.64 \text{ A}$$

4.2.2.6 Dimensions

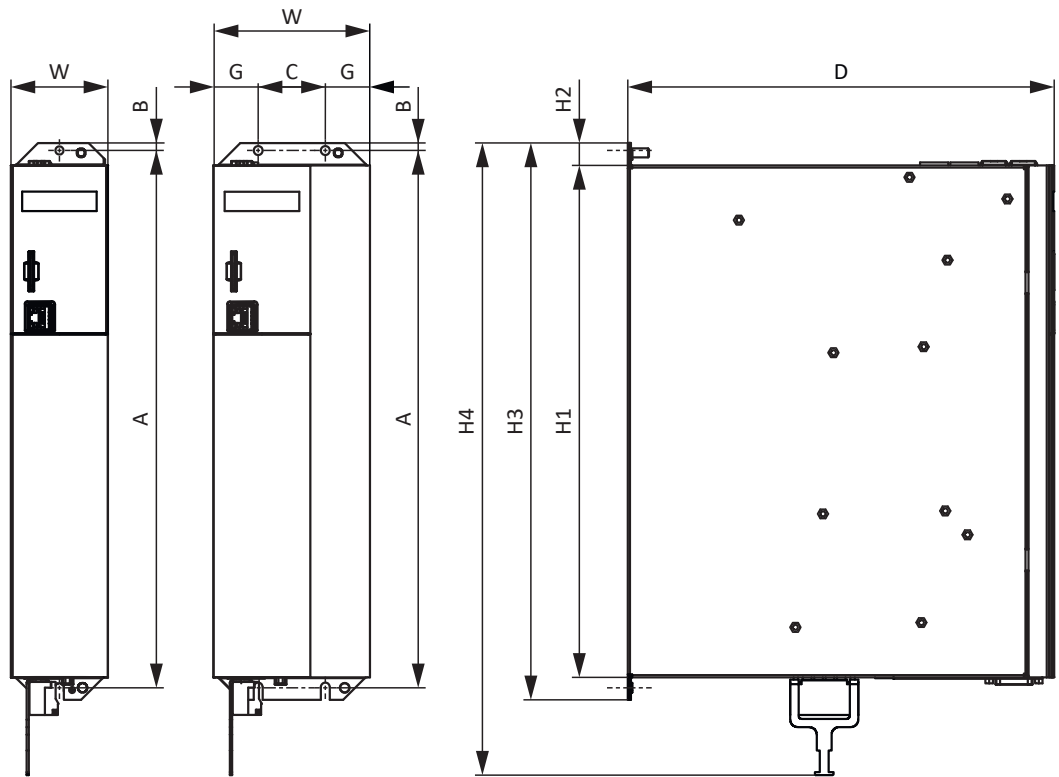

Fig. 2: SI6 dimensional drawing

Dimension		SI6A061 SI6A062	SI6A161 SI6A162	SI6A261	SI6A262	SI6A361
Drive controller	Width	W	45	65		105
	Depth	D	265	286		
	Body height	H1	343			
	Fastening clip height	H2	15			
	Height incl. fastening clips	H3	373			
	Total height incl. shield connection	H4	423			
Fastening bores (M5)	Vertical distance	A	360+2			
	Vertical distance to the upper edge	B	5			
	Horizontal distance of the fastening bores	C	—		45	
	Horizontal distance to the side edge	G	—		30	

Tab. 25: SI6 dimensions [mm]

Take the additional installation depth of the rear section modules into account when calculating the overall dimensions.

### 4.2.2.7 Weight

Type	Weight without packaging [g]	Weight with packaging [g]
SI6A061	2980	4600
SI6A062	3460	5060
SI6A161	3880	5260
SI6A162	4820	6240
SI6A261	4760	6200
SI6A262	6240	7420
SI6A361	6180	7360

Tab. 26: SI6 weight [g]

## 4.2.3 Supply module

The following section contains specifications for the electrical data, dimensions and weight of the PS6 supply module.

### 4.2.3.1 Type designation

PS	6	A	2	4
----	---	---	---	---

Tab. 27: Example code for supply module type designation

Code	Designation	Design
PS	Series	
6	Generation	Generation 6
A	Version	
2 – 4	Size	
4	Power output stage	

Tab. 28: Meaning of the example code

### 4.2.3.2 Sizes

Type	ID No.	Size
PS6A24	56650	Size 2
PS6A34	56651	Size 3
PS6A44	5050113	Size 4

Tab. 29: Available PS6 types and sizes



PS6 in sizes 3, 2 and 4

Note that the basic device is delivered without terminals. Suitable terminal sets are available separately for each size.

### 4.2.3.3 Electrical data

The electrical data of the available PS6 sizes as well as the properties of the brake chopper can be found in the following sections.

An explanation of the symbols used for formulas can be found in Chapter [\[ 9.1 \]](#).

#### 4.2.3.3.1 Control unit

Electrical data	All types
$U_{1CU}$	$24 V_{DC}$ , +20%/–15%
$I_{1maxCU}$	1.5 A

Tab. 30: Control unit electrical data

#### 4.2.3.3.2 Power unit: Size 2

Electrical data	PS6A24
$U_{1PU}$	$3 \times 400 V_{AC}$ , +32%/–50%, 50/60 Hz; $3 \times 480 V_{AC}$ , +10%/–58%, 50/60 Hz
$U_{2PU,ZK}$	$\sqrt{2} \times U_{1PU}$
$P_{2N,PU}$	10 kW
$I_{1N,PU}$	25 A
$I_{1maxPU}$	$I_{1N,PU} \times 180\%$ for 5 s; $I_{1N,PU} \times 150\%$ for 30 s
$C_{N,PU}$	5000 $\mu$ F

Tab. 31: PS6 electrical data, size 2

#### 4.2.3.3.3 Power unit: Size 3

Electrical data	PS6A34
$U_{1PU}$	$3 \times 400 V_{AC}$ , +32%/–50%, 50/60 Hz; $3 \times 480 V_{AC}$ , +10%/–58%, 50/60 Hz
$U_{2PU,ZK}$	$\sqrt{2} \times U_{1PU}$
$P_{2N,PU}$	20 kW
$I_{1N,PU}$	50 A
$I_{1maxPU}$	$I_{1N,PU} \times 180\%$ for 5 s; $I_{1N,PU} \times 150\%$ for 30 s
$C_{N,PU}$	10000 $\mu$ F

Tab. 32: PS6 electrical data, size 3

#### 4.2.3.3.4 Power unit: Size 4

Electrical data	PS6A44
$U_{1PU}$	$3 \times 400 V_{AC}$ , +32%/–50%, 50/60 Hz; $3 \times 480 V_{AC}$ , +10%/–58%, 50/60 Hz
$U_{2PU,ZK}$	$\sqrt{2} \times U_{1PU}$
$P_{2N,PU}$	50 kW
$I_{1N,PU}$	92 A
$I_{1maxPU}$	$I_{1N,PU} \times 180\%$ for 5 s; $I_{1N,PU} \times 150\%$ for 30 s
$C_{N,PU}$	20000 $\mu$ F

Tab. 33: PS6 electrical data, size 4

#### 4.2.3.3.5 Parallel connection

Only supply modules of either size 2 or 3 may be connected in parallel.

The power and current increase if supply modules are connected in parallel. Take into account that the total is derated by a factor of 0.8 in doing so.

The charging capacity of the supply modules can be increased by a parallel connection only if the power supply is connected to all supply modules simultaneously. Increasing the charging capacity also requires derating the total by a factor of 0.8.

The following table shows example combinations for parallel connection.

Electrical data	2 x PS6A24	3 x PS6A24	2 x PS6A34	3 x PS6A34
$P_{2N,PU}$	16 kW	24 kW	32 kW	48 kW
$I_{1N,PU}$	40 A	60 A	80 A	120 A
$C_{maxPU}$	8000 $\mu$ F	12000 $\mu$ F	16000 $\mu$ F	24000 $\mu$ F

Tab. 34: Electrical data for parallel connection: Example combinations

The following general conditions apply to the parallel connection of several PS6 supply modules:

- Only supply modules of size 2 or 3 may be connected in parallel.
- Only the same sizes may be connected in parallel.
- You can connect a maximum of 3 PS6A24 or 3 PS6A34 in parallel.

#### 4.2.3.3.6 Brake chopper

Electrical data	PS6A24	PS6A34
$U_{onCH}$	780 – 800 V <sub>DC</sub>	
$U_{offCH}$	740 – 760 V <sub>DC</sub>	
$R_{2minRB}$	22 $\Omega$	
$P_{maxRB}$	29.1 kW	
$P_{effRB}$	27.2 kW	

Tab. 35: Brake chopper electrical data, sizes 2 and 3

Electrical data	PS6A44
$U_{onCH}$	780 – 800 V <sub>DC</sub>
$U_{offCH}$	740 – 760 V <sub>DC</sub>
$R_{2minRB}$	9.5 $\Omega$
$P_{maxRB}$	67.3 kW
$P_{effRB}$	62.9 kW

Tab. 36: Brake chopper electrical data, size 4

#### 4.2.3.3.7 Fast discharge

Fast discharge is activated when no supply voltage is present for 20 s and the DC link voltage has reduced over this time. For active fast discharge, the DC link is discharged via the brake chopper and the braking resistor. Fast discharge does not take place for constant or increasing DC link voltage as this behavior indicates a second supply module in the DC link group. If the temperature sensor of the braking resistor is active, the fast discharge also remains off.

### 4.2.3.4 Dimensions

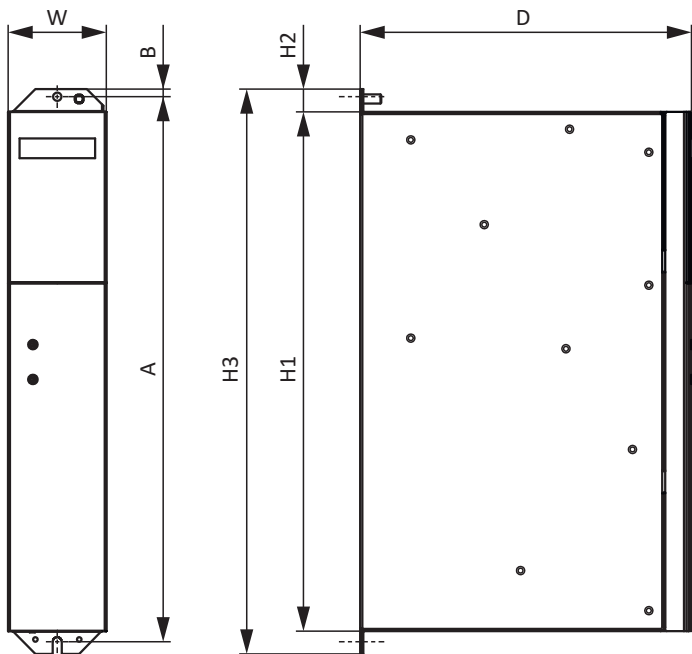

Fig. 3: PS6A24, PS6A34 dimensional drawing

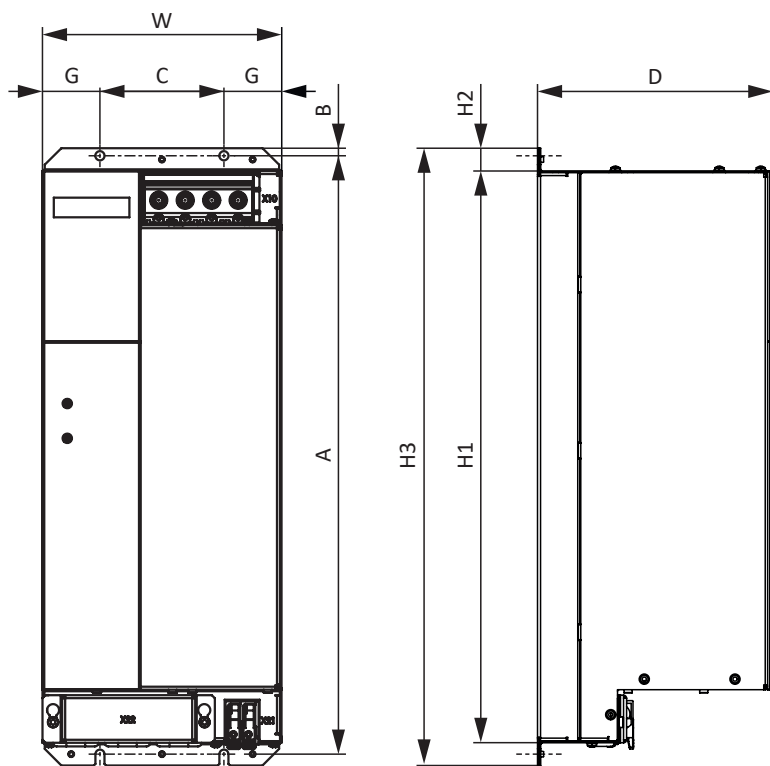

Fig. 4: PS6A44 dimensional drawing

Dimension			PS6A24	PS6A34	PS6A44
Supply module	Width	W	45	65	158
	Depth	D	204	219	156.5
	Body height	H1	343		378
	Fastening clip height	H2	15		
	Height incl. fastening clips	H3	373		408
Fastening bores (M5)	Vertical distance	A	360+2		396+2
	Vertical distance to the upper edge	B	5		
	Horizontal distance of the fastening bores	C	—		82
	Horizontal distance to the side edge	G	—		38

Tab. 37: PS6 dimensions [mm]

Take the additional installation depth of the rear section modules into account when calculating the overall dimensions.

#### 4.2.3.5 Weight

Type	Weight without packaging [g]	Weight with packaging [g]
PS6A24	2680	4180
PS6A34	3820	4920
PS6A44	6640	7640

Tab. 38: PS6 weight [g]

## 4.2.4 DC link connection

The following chapters contain the technical data of the DL6B Quick DC-Link modules.

### 4.2.4.1 General technical data

The following information applies to all Quick DC-Link modules and corresponds to the general technical data for the base device.

Device features	
Protection class of the device	IP20 (if built over with drive controller or supply module)
Protection class	Protection class I in accordance with EN 61140 (if built over with drive controller or supply module)
Protection class of the installation space	At least IP54

Tab. 39: Device features

Transport and storage conditions	
Storage/ transport temperature	-20 °C to +70 °C Maximum change: 20 K/h
Relative humidity	Maximum relative humidity 85%, non-condensing
Vibration (transport) in accordance with EN 60068-2-6	5 Hz ≤ f ≤ 9 Hz: 3.5 mm 9 Hz ≤ f ≤ 200 Hz: 10 m/s <sup>2</sup> 200 Hz ≤ f ≤ 500 Hz: 15 m/s <sup>2</sup>
Fall height for free fall <sup>6</sup> Weight < 100 kg in accordance with EN 61800-2 (or IEC 60721-3-2, class 2M4)	0.25 m
Shock testing in accordance with EN 60068-2-27	Pulse shape: Half-sine Acceleration: 5 g Shock duration: 30 ms Number of shocks: 3 per axis

Tab. 40: Transport and storage conditions

Operating conditions	
Surrounding temperature during operation	0 °C to 45 °C with nominal data 45 °C to 55 °C with derating -2.5% / K
Relative humidity	Maximum relative humidity 85%, non-condensing
Installation altitude	0 m to 1000 m above sea level without restrictions 1000 m to 2000 m above sea level with -1.5%/100 m derating
Pollution degree	Pollution degree 2 in accordance with EN 50178
Vibration (operation) in accordance with EN 60068-2-6	5 Hz ≤ f ≤ 9 Hz: 0.35 mm 9 Hz ≤ f ≤ 200 Hz: 1 m/s <sup>2</sup>

Tab. 41: Operating conditions

#### 4.2.4.2 Assignment to DL6B – SI6 and PS6

DL6B is available in the following designs suitable for the individual drive controller types and supply module types:

Type	DL6B10	DL6B11	DL6B12	DL6B20	DL6B21	DL6B22
ID No.	56655	56656	56663	56657	56658	5050114
SI6A061	X	—	—	—	—	—
SI6A062	X	—	—	—	—	—
SI6A161	—	X	—	—	—	—
SI6A162	—	X	—	—	—	—
SI6A261	—	X	—	—	—	—
SI6A262	—	—	X	—	—	—
SI6A361	—	—	X	—	—	—
PS6A24	—	—	—	X	—	—
PS6A34	—	—	—	—	X	—
PS6A44	—	—	—	—	—	X

Tab. 42: DL6B assignment to SI6 and PS6

### 4.2.4.3 Dimensions

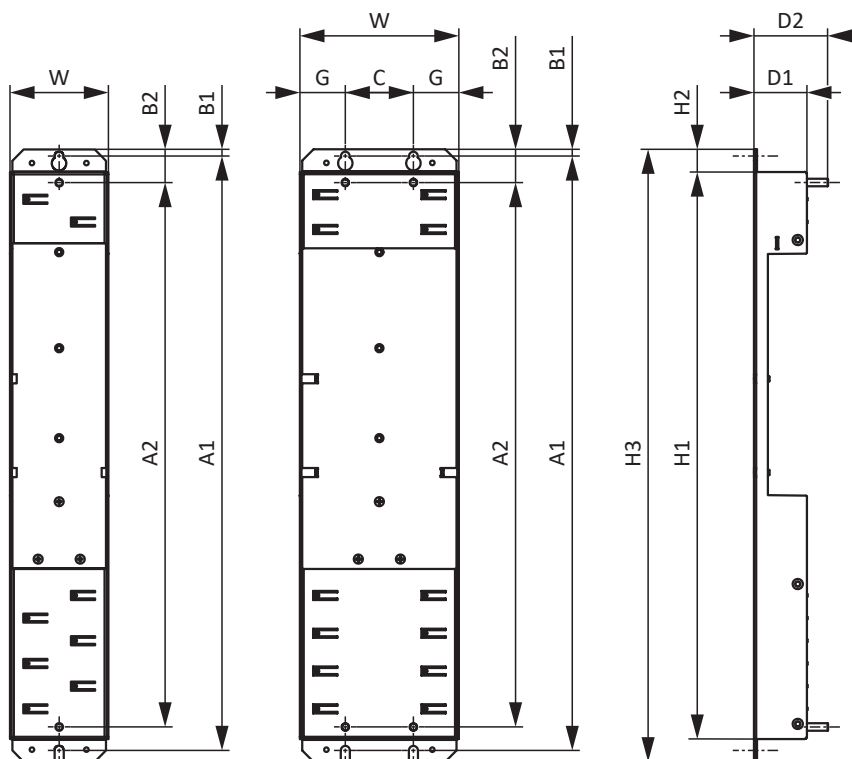

Fig. 5: Dimensional drawing of DL6B10 to DL6B21

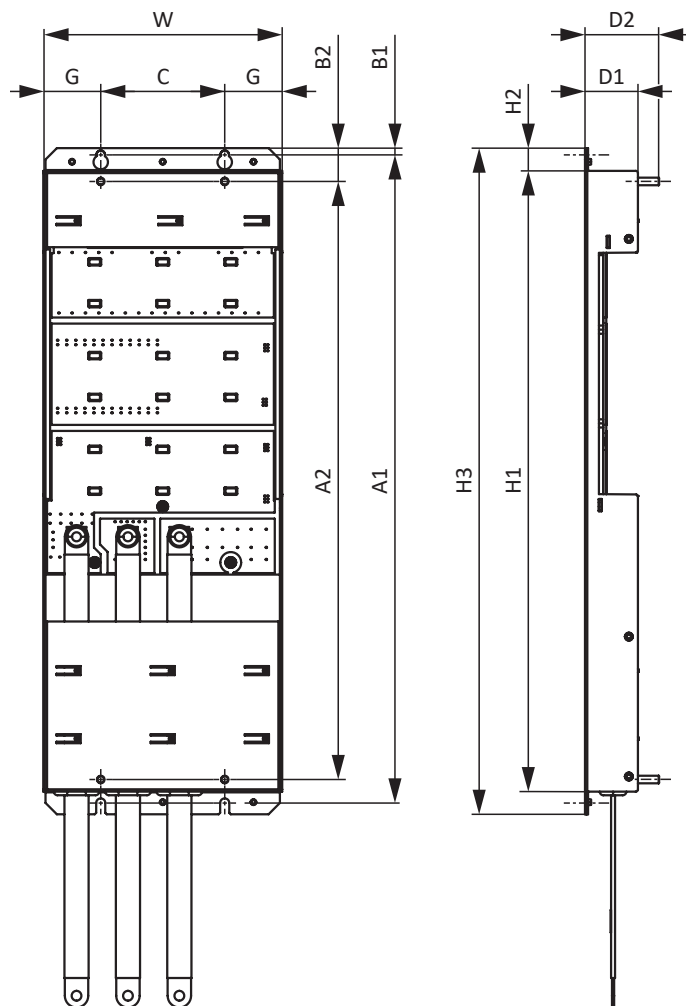

Fig. 6: DL6B22 dimensional drawing

Dimension			DL6B10	DL6B11	DL6B12	DL6B22
			DL6B20	DL6B21		
Quick DC-Link	Width	W	45	65	105	158
	Depth	D1	35			
	Depth incl. attachment bolts	D2	49			
	Height	H1	375			410.5
	Fastening clip height	H2	15			
	Height incl. fastening clips	H3	405			440.5
Fastening bores	Vertical distance (wall mounting)	A1	393+2			429+2
	Vertical distance (module mounting)	A2	360			396
	Vertical distance to the upper edge	B1	4.5			
	Vertical distance to the upper edge	B2	22			
	Horizontal distance of the fastening bores	C	—		45	82
	Horizontal distance to the side edge	G	—		30	38

Tab. 43: DL6B dimensions [mm]

#### 4.2.4.4 Weight

Type	Weight without packaging [g]	Weight with packaging [g]
DL6B10	440	480
DL6B11	560	600
DL6B12	880	920
DL6B20	480	520
DL6B21	740	780
DL6B22	1400	1440

Tab. 44: DL6B weight [g]

### 4.2.5 Minimum clearances

Drive controllers and supply modules

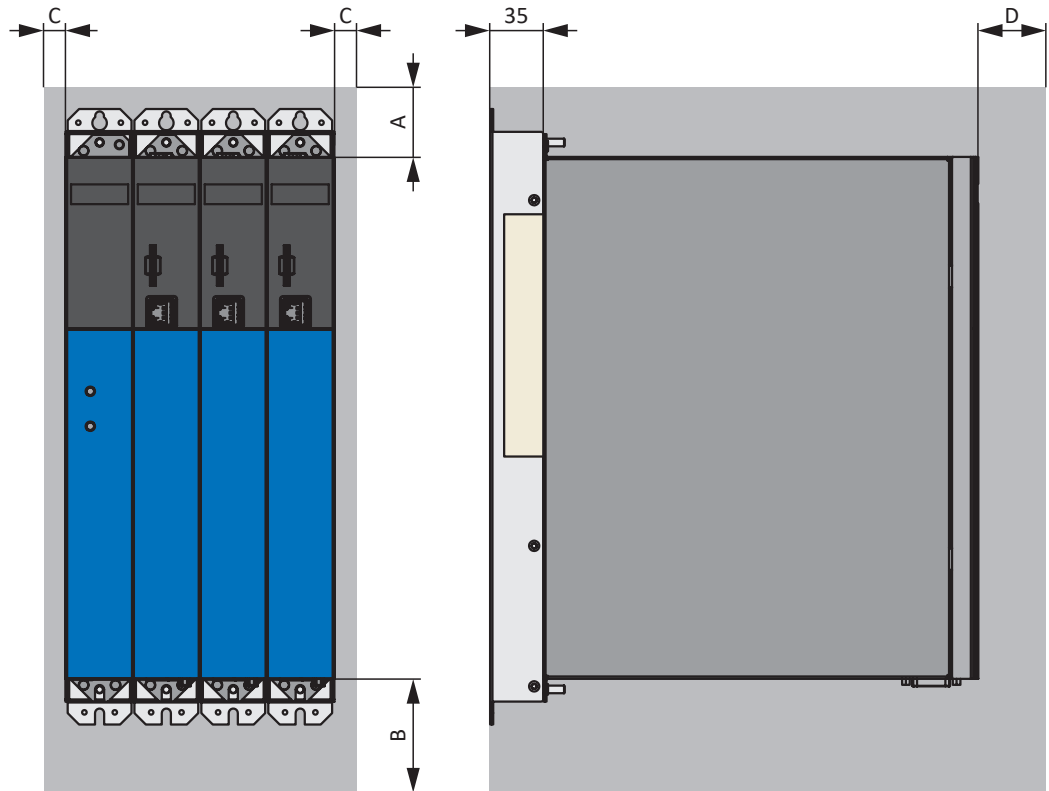

Fig. 7: Minimum clearances for drive controllers in combination with a PS6A24 or PS6A34 supply module

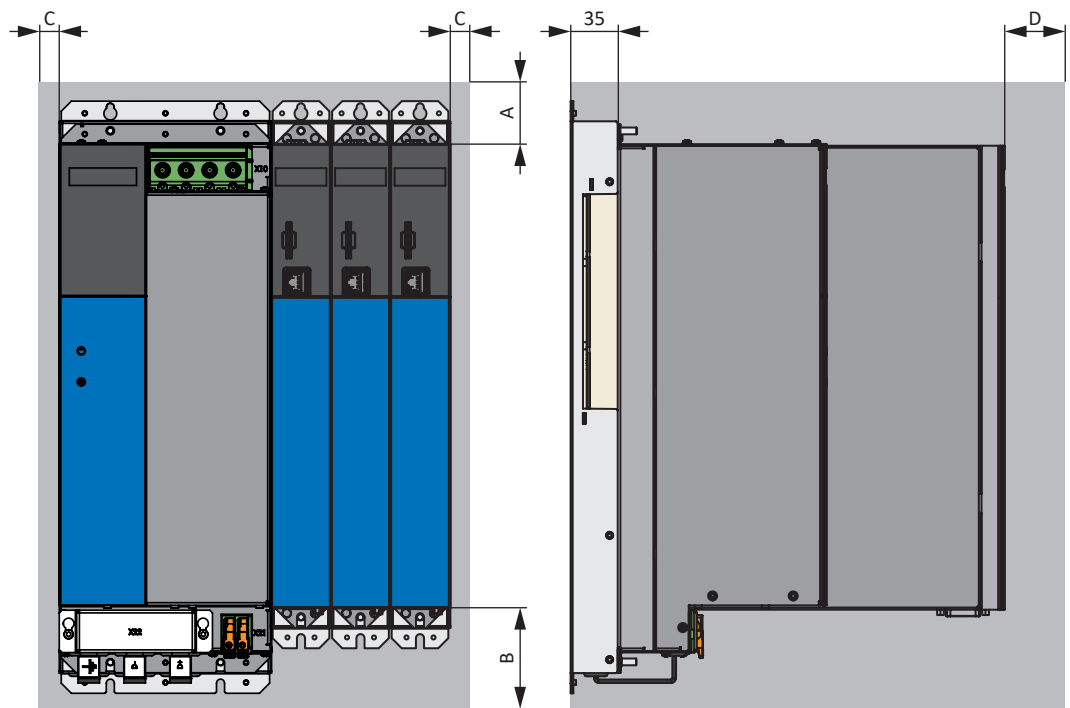

Fig. 8: Minimum clearances for drive controllers in combination with a PS6A44 supply module

Take into account the additional installation depth of 35 mm for the Quick DC-Link DL6B rear section modules.

The dimensions specified in the table relate to the outer edges of the drive controller or supply module.

Minimum clearance	A (above)	B (below)	C (on the side)	D (in front)
All sizes	100	200	5	50 <sup>7</sup>

Tab. 45: Minimum clearances [mm]

#### Chokes and filters

Avoid installation below drive controllers or supply modules. For installation in a control cabinet, a distance of approximately 100 mm to other neighboring components is recommended. This distance ensures proper heat dissipation for chokes and filters.

#### Braking resistors

Avoid installation below drive controllers or supply modules. In order for heated air to flow out unimpeded, a minimum clearance of approximately 200 mm must be maintained in relation to neighboring components or walls and approximately 300 mm must be maintained to components above or ceilings.

<sup>7</sup>Minimum clearance to be taken into account for permanent connection of the X9 service interface

## 4.3 Drive controller/motor combinations

An explanation of the symbols used for formulas can be found in Chapter [9.1](#).

### IC 410 convection cooling

Type	$K_{EM}$ [V/1000 min <sup>-1</sup> ]	$n_N$ [rpm]	$M_N$ [Nm]	$I_N$ [A]	$M_0$ [Nm]	$I_0$ [A]	Type	$f_{PWM,PU}$ [kHz]	$I_{2N,PU}$ [A]	$I_{2N,PU}/I_0$
<b>EZ2</b>										
EZ203U	40	6000	0.61	1.54	0.69	1.64	SI6A061	8	4.5	2.7
EZ203U	40	6000	0.61	1.54	0.69	1.64	SI6A062	8	4.5	2.7
<b>EZ3</b>										
EZ301U	40	3000	0.93	1.99	0.95	2.02	SI6A061	4	5	2.5
EZ301U	40	3000	0.93	1.99	0.95	2.02	SI6A061	8	4.5	2.2
EZ301U	40	3000	0.93	1.99	0.95	2.02	SI6A062	4	5	2.5
EZ301U	40	3000	0.93	1.99	0.95	2.02	SI6A062	8	4.5	2.2
EZ301U	40	6000	0.89	1.93	0.95	2.02	SI6A061	4	5	2.5
EZ301U	40	6000	0.89	1.93	0.95	2.02	SI6A061	8	4.5	2.2
EZ301U	40	6000	0.89	1.93	0.95	2.02	SI6A062	4	5	2.5
EZ301U	40	6000	0.89	1.93	0.95	2.02	SI6A062	8	4.5	2.2
EZ302U	86	3000	1.59	1.60	1.68	1.67	SI6A061	4	5	3.0
EZ302U	86	3000	1.59	1.60	1.68	1.67	SI6A061	8	4.5	2.7
EZ302U	86	3000	1.59	1.60	1.68	1.67	SI6A062	4	5	3.0
EZ302U	86	3000	1.59	1.60	1.68	1.67	SI6A062	8	4.5	2.7
EZ302U	42	6000	1.50	3.18	1.68	3.48	SI6A061	4	5	1.4
EZ302U	42	6000	1.50	3.18	1.68	3.48	SI6A061	8	4.5	1.3
EZ302U	42	6000	1.50	3.18	1.68	3.48	SI6A062	4	5	1.4
EZ302U	42	6000	1.50	3.18	1.68	3.48	SI6A062	8	4.5	1.3
EZ302U	42	6000	1.50	3.18	1.68	3.48	SI6A161	8	10	2.9
EZ302U	42	6000	1.50	3.18	1.68	3.48	SI6A162	8	10	2.9
EZ303U	109	3000	2.07	1.63	2.19	1.71	SI6A061	4	5	2.9
EZ303U	109	3000	2.07	1.63	2.19	1.71	SI6A061	8	4.5	2.6
EZ303U	109	3000	2.07	1.63	2.19	1.71	SI6A062	4	5	2.9
EZ303U	109	3000	2.07	1.63	2.19	1.71	SI6A062	8	4.5	2.6
EZ303U	55	6000	1.96	3.17	2.25	3.55	SI6A061	4	5	1.4
EZ303U	55	6000	1.96	3.17	2.25	3.55	SI6A061	8	4.5	1.3
EZ303U	55	6000	1.96	3.17	2.25	3.55	SI6A062	4	5	1.4
EZ303U	55	6000	1.96	3.17	2.25	3.55	SI6A062	8	4.5	1.3
EZ303U	55	6000	1.96	3.17	2.25	3.55	SI6A161	8	10	2.8
EZ303U	55	6000	1.96	3.17	2.25	3.55	SI6A162	8	10	2.8
<b>EZ4</b>										
EZ401U	96	3000	2.80	2.74	3.00	2.88	SI6A061	4	5	1.7
EZ401U	96	3000	2.80	2.74	3.00	2.88	SI6A061	8	4.5	1.6
EZ401U	96	3000	2.80	2.74	3.00	2.88	SI6A062	4	5	1.7
EZ401U	96	3000	2.80	2.74	3.00	2.88	SI6A062	8	4.5	1.6
EZ401U	47	6000	2.30	4.56	2.80	5.36	SI6A161	4	12	2.2
EZ401U	47	6000	2.30	4.56	2.80	5.36	SI6A161	8	10	1.9
EZ401U	47	6000	2.30	4.56	2.80	5.36	SI6A162	4	12	2.2
EZ401U	47	6000	2.30	4.56	2.80	5.36	SI6A162	8	10	1.9
EZ402U	94	3000	4.70	4.40	5.20	4.80	SI6A061	4	5	1.0
EZ402U	94	3000	4.70	4.40	5.20	4.80	SI6A062	4	5	1.0
EZ402U	94	3000	4.70	4.40	5.20	4.80	SI6A161	4	12	2.5
EZ402U	94	3000	4.70	4.40	5.20	4.80	SI6A161	8	10	2.1
EZ402U	94	3000	4.70	4.40	5.20	4.80	SI6A162	4	12	2.5
EZ402U	94	3000	4.70	4.40	5.20	4.80	SI6A162	8	10	2.1
EZ402U	60	6000	3.50	5.65	4.90	7.43	SI6A161	4	12	1.6
EZ402U	60	6000	3.50	5.65	4.90	7.43	SI6A161	8	10	1.4
EZ402U	60	6000	3.50	5.65	4.90	7.43	SI6A162	4	12	1.6
EZ402U	60	6000	3.50	5.65	4.90	7.43	SI6A162	8	10	1.4
EZ402U	60	6000	3.50	5.65	4.90	7.43	SI6A261	4	22	3.0
EZ402U	60	6000	3.50	5.65	4.90	7.43	SI6A261	8	20	2.7
EZ402U	60	6000	3.50	5.65	4.90	7.43	SI6A262	8	20	2.7
EZ404U	116	3000	6.90	5.80	8.60	6.60	SI6A161	4	12	1.8
EZ404U	116	3000	6.90	5.80	8.60	6.60	SI6A161	8	10	1.5
EZ404U	116	3000	6.90	5.80	8.60	6.60	SI6A162	4	12	1.8
EZ404U	116	3000	6.90	5.80	8.60	6.60	SI6A162	8	10	1.5
EZ404U	78	6000	5.80	7.18	8.40	9.78	SI6A161	4	12	1.2
EZ404U	78	6000	5.80	7.18	8.40	9.78	SI6A161	8	10	1.0

Type	$K_{EM}$ [V/1000 min <sup>-1</sup> ]	$n_N$ [rpm]	$M_N$ [Nm]	$I_N$ [A]	$M_0$ [Nm]	$I_0$ [A]	Type	$f_{PWM,PU}$ [kHz]	$I_{2N,PU}$ [A]	$I_{2N,PU}/I_0$
<b>EZ4</b>										
EZ404U	78	6000	5.80	7.18	8.40	9.78	SI6A162	4	12	1.2
EZ404U	78	6000	5.80	7.18	8.40	9.78	SI6A162	8	10	1.0
EZ404U	78	6000	5.80	7.18	8.40	9.78	SI6A261	4	22	2.3
EZ404U	78	6000	5.80	7.18	8.40	9.78	SI6A261	8	20	2.0
EZ404U	78	6000	5.80	7.18	8.40	9.78	SI6A262	4	25	2.6
EZ404U	78	6000	5.80	7.18	8.40	9.78	SI6A262	8	20	2.0
<b>EZ5</b>										
EZ501U	97	3000	4.30	3.74	4.70	4.00	SI6A061	4	5	1.3
EZ501U	97	3000	4.30	3.74	4.70	4.00	SI6A061	8	4.5	1.1
EZ501U	97	3000	4.30	3.74	4.70	4.00	SI6A062	4	5	1.3
EZ501U	97	3000	4.30	3.74	4.70	4.00	SI6A062	8	4.5	1.1
EZ501U	97	3000	4.30	3.74	4.70	4.00	SI6A161	4	12	3.0
EZ501U	97	3000	4.30	3.74	4.70	4.00	SI6A161	8	10	2.5
EZ501U	97	3000	4.30	3.74	4.70	4.00	SI6A162	4	12	3.0
EZ501U	97	3000	4.30	3.74	4.70	4.00	SI6A162	8	10	2.5
EZ501U	68	6000	3.40	4.77	4.40	5.80	SI6A161	4	12	2.1
EZ501U	68	6000	3.40	4.77	4.40	5.80	SI6A161	8	10	1.7
EZ501U	68	6000	3.40	4.77	4.40	5.80	SI6A162	4	12	2.1
EZ501U	68	6000	3.40	4.77	4.40	5.80	SI6A162	8	10	1.7
EZ502U	121	3000	7.40	5.46	8.00	5.76	SI6A161	4	12	2.1
EZ502U	121	3000	7.40	5.46	8.00	5.76	SI6A161	8	10	1.7
EZ502U	121	3000	7.40	5.46	8.00	5.76	SI6A162	4	12	2.1
EZ502U	121	3000	7.40	5.46	8.00	5.76	SI6A162	8	10	1.7
EZ502U	72	6000	5.20	7.35	7.80	9.80	SI6A161	4	12	1.2
EZ502U	72	6000	5.20	7.35	7.80	9.80	SI6A161	8	10	1.0
EZ502U	72	6000	5.20	7.35	7.80	9.80	SI6A162	4	12	1.2
EZ502U	72	6000	5.20	7.35	7.80	9.80	SI6A162	8	10	1.0
EZ502U	72	6000	5.20	7.35	7.80	9.80	SI6A261	4	22	2.2
EZ502U	72	6000	5.20	7.35	7.80	9.80	SI6A261	8	20	2.0
EZ502U	72	6000	5.20	7.35	7.80	9.80	SI6A262	4	25	2.6
EZ502U	72	6000	5.20	7.35	7.80	9.80	SI6A262	8	20	2.0
EZ503U	119	3000	9.70	6.90	11.1	7.67	SI6A161	4	12	1.6
EZ503U	119	3000	9.70	6.90	11.1	7.67	SI6A161	8	10	1.3
EZ503U	119	3000	9.70	6.90	11.1	7.67	SI6A162	4	12	1.6
EZ503U	119	3000	9.70	6.90	11.1	7.67	SI6A162	8	10	1.3
EZ503U	119	3000	9.70	6.90	11.1	7.67	SI6A261	4	22	2.9
EZ503U	119	3000	9.70	6.90	11.1	7.67	SI6A261	8	20	2.6
EZ503U	119	3000	9.70	6.90	11.1	7.67	SI6A262	8	20	2.6
EZ503U	84	6000	6.20	7.64	10.6	11.6	SI6A161	4	12	1.0
EZ503U	84	6000	6.20	7.64	10.6	11.6	SI6A162	4	12	1.0
EZ503U	84	6000	6.20	7.64	10.6	11.6	SI6A261	4	22	1.9
EZ503U	84	6000	6.20	7.64	10.6	11.6	SI6A261	8	20	1.7
EZ503U	84	6000	6.20	7.64	10.6	11.6	SI6A262	4	25	2.2
EZ503U	84	6000	6.20	7.64	10.6	11.6	SI6A262	8	20	1.7
EZ505U	141	3000	13.5	8.80	16.0	10.0	SI6A161	4	12	1.2
EZ505U	141	3000	13.5	8.80	16.0	10.0	SI6A161	8	10	1.0
EZ505U	141	3000	13.5	8.80	16.0	10.0	SI6A162	4	12	1.2
EZ505U	141	3000	13.5	8.80	16.0	10.0	SI6A162	8	10	1.0
EZ505U	141	3000	13.5	8.80	16.0	10.0	SI6A261	4	22	2.2
EZ505U	141	3000	13.5	8.80	16.0	10.0	SI6A261	8	20	2.0
EZ505U	141	3000	13.5	8.80	16.0	10.0	SI6A262	4	25	2.5
EZ505U	141	3000	13.5	8.80	16.0	10.0	SI6A262	8	20	2.0
EZ505U	103	4500	9.50	8.94	15.3	13.4	SI6A261	4	22	1.6
EZ505U	103	4500	9.50	8.94	15.3	13.4	SI6A261	8	20	1.5
EZ505U	103	4500	9.50	8.94	15.3	13.4	SI6A262	4	25	1.9
EZ505U	103	4500	9.50	8.94	15.3	13.4	SI6A262	8	20	1.5
EZ505U	103	4500	9.50	8.94	15.3	13.4	SI6A361	8	40	3.0
<b>EZ7</b>										
EZ701U	95	3000	7.40	7.20	8.30	8.00	SI6A161	4	12	1.5
EZ701U	95	3000	7.40	7.20	8.30	8.00	SI6A161	8	10	1.3
EZ701U	95	3000	7.40	7.20	8.30	8.00	SI6A162	4	12	1.5
EZ701U	95	3000	7.40	7.20	8.30	8.00	SI6A162	8	10	1.3
EZ701U	95	3000	7.40	7.20	8.30	8.00	SI6A261	4	22	2.8
EZ701U	95	3000	7.40	7.20	8.30	8.00	SI6A261	8	20	2.5
EZ701U	95	3000	7.40	7.20	8.30	8.00	SI6A262	8	20	2.5

4.3 Drive controller/motor combinations 4 SI6 drive controllers

Type	$K_{EM}$ [V/1000 min <sup>-1</sup> ]	$n_N$ [rpm]	$M_N$ [Nm]	$I_N$ [A]	$M_0$ [Nm]	$I_0$ [A]	Type	$f_{PWM,PU}$ [kHz]	$I_{2N,PU}$ [A]	$I_{2N,PU}/I_0$
<b>EZ7</b>										
EZ701U	76	6000	5.20	6.68	7.90	9.38	SI6A161	4	12	1.3
EZ701U	76	6000	5.20	6.68	7.90	9.38	SI6A161	8	10	1.1
EZ701U	76	6000	5.20	6.68	7.90	9.38	SI6A162	4	12	1.3
EZ701U	76	6000	5.20	6.68	7.90	9.38	SI6A162	8	10	1.1
EZ701U	76	6000	5.20	6.68	7.90	9.38	SI6A261	4	22	2.4
EZ701U	76	6000	5.20	6.68	7.90	9.38	SI6A261	8	20	2.1
EZ701U	76	6000	5.20	6.68	7.90	9.38	SI6A262	4	25	2.7
EZ701U	76	6000	5.20	6.68	7.90	9.38	SI6A262	8	20	2.1
EZ702U	133	3000	12.0	8.20	14.4	9.60	SI6A161	4	12	1.3
EZ702U	133	3000	12.0	8.20	14.4	9.60	SI6A161	8	10	1.0
EZ702U	133	3000	12.0	8.20	14.4	9.60	SI6A162	4	12	1.3
EZ702U	133	3000	12.0	8.20	14.4	9.60	SI6A162	8	10	1.0
EZ702U	133	3000	12.0	8.20	14.4	9.60	SI6A261	4	22	2.3
EZ702U	133	3000	12.0	8.20	14.4	9.60	SI6A261	8	20	2.1
EZ702U	133	3000	12.0	8.20	14.4	9.60	SI6A262	4	25	2.6
EZ702U	133	3000	12.0	8.20	14.4	9.60	SI6A262	8	20	2.1
EZ702U	82	6000	7.20	8.96	14.3	16.5	SI6A261	4	22	1.3
EZ702U	82	6000	7.20	8.96	14.3	16.5	SI6A261	8	20	1.2
EZ702U	82	6000	7.20	8.96	14.3	16.5	SI6A262	4	25	1.5
EZ702U	82	6000	7.20	8.96	14.3	16.5	SI6A262	8	20	1.2
EZ702U	82	6000	7.20	8.96	14.3	16.5	SI6A361	8	40	2.4
EZ703U	122	3000	16.5	11.4	20.8	14.0	SI6A261	4	22	1.6
EZ703U	122	3000	16.5	11.4	20.8	14.0	SI6A261	8	20	1.4
EZ703U	122	3000	16.5	11.4	20.8	14.0	SI6A262	4	25	1.8
EZ703U	122	3000	16.5	11.4	20.8	14.0	SI6A262	8	20	1.4
EZ703U	122	3000	16.5	11.4	20.8	14.0	SI6A361	8	40	2.9
EZ703U	99	4500	12.1	11.5	20.0	17.8	SI6A261	4	22	1.2
EZ703U	99	4500	12.1	11.5	20.0	17.8	SI6A261	8	20	1.1
EZ703U	99	4500	12.1	11.5	20.0	17.8	SI6A262	4	25	1.4
EZ703U	99	4500	12.1	11.5	20.0	17.8	SI6A262	8	20	1.1
EZ703U	99	4500	12.1	11.5	20.0	17.8	SI6A361	4	50	2.8
EZ703U	99	4500	12.1	11.5	20.0	17.8	SI6A361	8	40	2.3
EZ705U	140	3000	21.3	14.2	30.2	19.5	SI6A261	4	22	1.1
EZ705U	140	3000	21.3	14.2	30.2	19.5	SI6A261	8	20	1.0
EZ705U	140	3000	21.3	14.2	30.2	19.5	SI6A262	4	25	1.3
EZ705U	140	3000	21.3	14.2	30.2	19.5	SI6A262	8	20	1.0
EZ705U	140	3000	21.3	14.2	30.2	19.5	SI6A361	4	50	2.6
EZ705U	140	3000	21.3	14.2	30.2	19.5	SI6A361	8	40	2.1
EZ705U	106	4500	16.4	14.8	30.0	25.2	SI6A361	4	50	2.0
EZ705U	106	4500	16.4	14.8	30.0	25.2	SI6A361	8	40	1.6
<b>EZ8</b>										
EZ813U	239	2000	39.0	14.9	43.7	16.5	SI6A261	4	22	1.3
EZ813U	239	2000	39.0	14.9	43.7	16.5	SI6A261	8	20	1.2
EZ813U	239	2000	39.0	14.9	43.7	16.5	SI6A262	4	25	1.5
EZ813U	239	2000	39.0	14.9	43.7	16.5	SI6A262	8	20	1.2
EZ813U	239	2000	39.0	14.9	43.7	16.5	SI6A361	8	40	2.4
EZ813U	117	4000	25.2	19.8	43.7	32.8	SI6A361	4	50	1.5
EZ813U	117	4000	25.2	19.8	43.7	32.8	SI6A361	8	40	1.2
EZ815U	239	2000	57.8	21.5	68.8	25.2	SI6A361	4	50	2.0
EZ815U	239	2000	57.8	21.5	68.8	25.2	SI6A361	8	40	1.6

## IC 416 forced ventilation

Type	$K_{EM}$ [V/1000 min <sup>-1</sup> ]	$n_N$ [rpm]	$M_N$ [Nm]	$I_N$ [A]	$M_0$ [Nm]	$I_0$ [A]	Type	$f_{PWM,PU}$ [kHz]	$I_{2N,PU}$ [A]	$I_{2N,PU}/I_0$
<b>EZ4</b>										
EZ401B	96	3000	3.40	3.40	3.70	3.60	SI6A061	4	5	1.4
EZ401B	96	3000	3.40	3.40	3.70	3.60	SI6A061	8	4.5	1.3
EZ401B	96	3000	3.40	3.40	3.70	3.60	SI6A062	4	5	1.4
EZ401B	96	3000	3.40	3.40	3.70	3.60	SI6A062	8	4.5	1.3
EZ401B	96	3000	3.40	3.40	3.70	3.60	SI6A161	8	10	2.8
EZ401B	96	3000	3.40	3.40	3.70	3.60	SI6A162	8	10	2.8
EZ401B	47	6000	2.90	5.62	3.50	6.83	SI6A161	4	12	1.8
EZ401B	47	6000	2.90	5.62	3.50	6.83	SI6A161	8	10	1.5
EZ401B	47	6000	2.90	5.62	3.50	6.83	SI6A162	4	12	1.8
EZ401B	47	6000	2.90	5.62	3.50	6.83	SI6A162	8	10	1.5
EZ401B	47	6000	2.90	5.62	3.50	6.83	SI6A261	8	20	2.9
EZ401B	47	6000	2.90	5.62	3.50	6.83	SI6A262	8	20	2.9
EZ402B	94	3000	5.90	5.50	6.30	5.80	SI6A161	4	12	2.1
EZ402B	94	3000	5.90	5.50	6.30	5.80	SI6A161	8	10	1.7
EZ402B	94	3000	5.90	5.50	6.30	5.80	SI6A162	4	12	2.1
EZ402B	94	3000	5.90	5.50	6.30	5.80	SI6A162	8	10	1.7
EZ402B	60	6000	5.10	7.88	6.40	9.34	SI6A161	4	12	1.3
EZ402B	60	6000	5.10	7.88	6.40	9.34	SI6A161	8	10	1.1
EZ402B	60	6000	5.10	7.88	6.40	9.34	SI6A162	4	12	1.3
EZ402B	60	6000	5.10	7.88	6.40	9.34	SI6A162	8	10	1.1
EZ402B	60	6000	5.10	7.88	6.40	9.34	SI6A261	4	22	2.4
EZ402B	60	6000	5.10	7.88	6.40	9.34	SI6A261	8	20	2.1
EZ402B	60	6000	5.10	7.88	6.40	9.34	SI6A262	4	25	2.7
EZ402B	60	6000	5.10	7.88	6.40	9.34	SI6A262	8	20	2.1
EZ404B	116	3000	10.2	8.20	11.2	8.70	SI6A161	4	12	1.4
EZ404B	116	3000	10.2	8.20	11.2	8.70	SI6A161	8	10	1.2
EZ404B	116	3000	10.2	8.20	11.2	8.70	SI6A162	4	12	1.4
EZ404B	116	3000	10.2	8.20	11.2	8.70	SI6A162	8	10	1.2
EZ404B	116	3000	10.2	8.20	11.2	8.70	SI6A261	4	22	2.5
EZ404B	116	3000	10.2	8.20	11.2	8.70	SI6A261	8	20	2.3
EZ404B	116	3000	10.2	8.20	11.2	8.70	SI6A262	4	25	2.9
EZ404B	116	3000	10.2	8.20	11.2	8.70	SI6A262	8	20	2.3
EZ404B	78	6000	8.00	9.98	10.5	12.0	SI6A161	4	12	1.0
EZ404B	78	6000	8.00	9.98	10.5	12.0	SI6A162	4	12	1.0
EZ404B	78	6000	8.00	9.98	10.5	12.0	SI6A261	4	22	1.8
EZ404B	78	6000	8.00	9.98	10.5	12.0	SI6A261	8	20	1.7
EZ404B	78	6000	8.00	9.98	10.5	12.0	SI6A262	4	25	2.1
EZ404B	78	6000	8.00	9.98	10.5	12.0	SI6A262	8	20	1.7
<b>EZ5</b>										
EZ501B	97	3000	5.40	4.70	5.80	5.00	SI6A061	4	5	1.0
EZ501B	97	3000	5.40	4.70	5.80	5.00	SI6A062	4	5	1.0
EZ501B	97	3000	5.40	4.70	5.80	5.00	SI6A161	4	12	2.4
EZ501B	97	3000	5.40	4.70	5.80	5.00	SI6A161	8	10	2.0
EZ501B	97	3000	5.40	4.70	5.80	5.00	SI6A162	4	12	2.4
EZ501B	97	3000	5.40	4.70	5.80	5.00	SI6A162	8	10	2.0
EZ501B	68	6000	4.50	6.70	5.70	7.50	SI6A161	4	12	1.6
EZ501B	68	6000	4.50	6.70	5.70	7.50	SI6A161	8	10	1.3
EZ501B	68	6000	4.50	6.70	5.70	7.50	SI6A162	4	12	1.6
EZ501B	68	6000	4.50	6.70	5.70	7.50	SI6A162	8	10	1.3
EZ501B	68	6000	4.50	6.70	5.70	7.50	SI6A261	4	22	2.9
EZ501B	68	6000	4.50	6.70	5.70	7.50	SI6A261	8	20	2.7
EZ501B	68	6000	4.50	6.70	5.70	7.50	SI6A262	8	20	2.7
EZ502B	121	3000	10.3	7.80	11.2	8.16	SI6A161	4	12	1.5
EZ502B	121	3000	10.3	7.80	11.2	8.16	SI6A161	8	10	1.2
EZ502B	121	3000	10.3	7.80	11.2	8.16	SI6A162	4	12	1.5
EZ502B	121	3000	10.3	7.80	11.2	8.16	SI6A162	8	10	1.2
EZ502B	121	3000	10.3	7.80	11.2	8.16	SI6A261	4	22	2.7
EZ502B	121	3000	10.3	7.80	11.2	8.16	SI6A261	8	20	2.5
EZ502B	121	3000	10.3	7.80	11.2	8.16	SI6A262	8	20	2.5
EZ502B	72	6000	8.20	11.4	10.5	13.4	SI6A261	4	22	1.6
EZ502B	72	6000	8.20	11.4	10.5	13.4	SI6A261	8	20	1.5
EZ502B	72	6000	8.20	11.4	10.5	13.4	SI6A262	4	25	1.9
EZ502B	72	6000	8.20	11.4	10.5	13.4	SI6A262	8	20	1.5
EZ502B	72	6000	8.20	11.4	10.5	13.4	SI6A361	8	40	3.0

4.3 Drive controller/motor combinations 4 SI6 drive controllers

Type	$K_{EM}$ [V/1000 min <sup>-1</sup> ]	$n_N$ [rpm]	$M_N$ [Nm]	$I_N$ [A]	$M_0$ [Nm]	$I_0$ [A]	Type	$f_{PWM,PU}$ [kHz]	$I_{2N,PU}$ [A]	$I_{2N,PU}/I_0$
<b>EZ5</b>										
EZ503B	119	3000	14.4	10.9	15.9	11.8	SI6A161	4	12	1.0
EZ503B	119	3000	14.4	10.9	15.9	11.8	SI6A162	4	12	1.0
EZ503B	119	3000	14.4	10.9	15.9	11.8	SI6A261	4	22	1.9
EZ503B	119	3000	14.4	10.9	15.9	11.8	SI6A261	8	20	1.7
EZ503B	119	3000	14.4	10.9	15.9	11.8	SI6A262	4	25	2.1
EZ503B	119	3000	14.4	10.9	15.9	11.8	SI6A262	8	20	1.7
EZ503B	84	6000	10.4	13.5	14.8	15.9	SI6A261	4	22	1.4
EZ503B	84	6000	10.4	13.5	14.8	15.9	SI6A261	8	20	1.3
EZ503B	84	6000	10.4	13.5	14.8	15.9	SI6A262	4	25	1.6
EZ503B	84	6000	10.4	13.5	14.8	15.9	SI6A262	8	20	1.3
EZ503B	84	6000	10.4	13.5	14.8	15.9	SI6A361	8	40	2.5
EZ505B	141	3000	20.2	13.7	23.4	14.7	SI6A261	4	22	1.5
EZ505B	141	3000	20.2	13.7	23.4	14.7	SI6A261	8	20	1.4
EZ505B	141	3000	20.2	13.7	23.4	14.7	SI6A262	4	25	1.7
EZ505B	141	3000	20.2	13.7	23.4	14.7	SI6A262	8	20	1.4
EZ505B	141	3000	20.2	13.7	23.4	14.7	SI6A361	8	40	2.7
EZ505B	103	4500	16.4	16.4	22.0	19.4	SI6A261	4	22	1.1
EZ505B	103	4500	16.4	16.4	22.0	19.4	SI6A261	8	20	1.0
EZ505B	103	4500	16.4	16.4	22.0	19.4	SI6A262	4	25	1.3
EZ505B	103	4500	16.4	16.4	22.0	19.4	SI6A262	8	20	1.0
EZ505B	103	4500	16.4	16.4	22.0	19.4	SI6A361	4	50	2.6
EZ505B	103	4500	16.4	16.4	22.0	19.4	SI6A361	8	40	2.1
<b>EZ7</b>										
EZ701B	95	3000	9.70	9.50	10.5	10.0	SI6A161	4	12	1.2
EZ701B	95	3000	9.70	9.50	10.5	10.0	SI6A161	8	10	1.0
EZ701B	95	3000	9.70	9.50	10.5	10.0	SI6A162	4	12	1.2
EZ701B	95	3000	9.70	9.50	10.5	10.0	SI6A162	8	10	1.0
EZ701B	95	3000	9.70	9.50	10.5	10.0	SI6A261	4	22	2.2
EZ701B	95	3000	9.70	9.50	10.5	10.0	SI6A261	8	20	2.0
EZ701B	95	3000	9.70	9.50	10.5	10.0	SI6A262	4	25	2.5
EZ701B	95	3000	9.70	9.50	10.5	10.0	SI6A262	8	20	2.0
EZ701B	76	6000	7.50	10.6	10.2	12.4	SI6A261	4	22	1.8
EZ701B	76	6000	7.50	10.6	10.2	12.4	SI6A261	8	20	1.6
EZ701B	76	6000	7.50	10.6	10.2	12.4	SI6A262	4	25	2.0
EZ701B	76	6000	7.50	10.6	10.2	12.4	SI6A262	8	20	1.6
EZ702B	133	3000	16.6	11.8	19.3	12.9	SI6A261	4	22	1.7
EZ702B	133	3000	16.6	11.8	19.3	12.9	SI6A261	8	20	1.6
EZ702B	133	3000	16.6	11.8	19.3	12.9	SI6A262	4	25	1.9
EZ702B	133	3000	16.6	11.8	19.3	12.9	SI6A262	8	20	1.6
EZ702B	82	6000	12.5	16.7	19.3	22.1	SI6A261	4	22	1.0
EZ702B	82	6000	12.5	16.7	19.3	22.1	SI6A262	4	25	1.1
EZ702B	82	6000	12.5	16.7	19.3	22.1	SI6A361	4	50	2.3
EZ702B	82	6000	12.5	16.7	19.3	22.1	SI6A361	8	40	1.8
EZ703B	122	3000	24.0	18.2	28.0	20.0	SI6A261	4	22	1.1
EZ703B	122	3000	24.0	18.2	28.0	20.0	SI6A261	8	20	1.0
EZ703B	122	3000	24.0	18.2	28.0	20.0	SI6A262	4	25	1.3
EZ703B	122	3000	24.0	18.2	28.0	20.0	SI6A262	8	20	1.0
EZ703B	122	3000	24.0	18.2	28.0	20.0	SI6A361	4	50	2.5
EZ703B	122	3000	24.0	18.2	28.0	20.0	SI6A361	8	40	2.0
EZ703B	99	4500	19.8	20.3	27.2	24.2	SI6A262	4	25	1.0
EZ703B	99	4500	19.8	20.3	27.2	24.2	SI6A361	4	50	2.1
EZ703B	99	4500	19.8	20.3	27.2	24.2	SI6A361	8	40	1.7
EZ705B	140	3000	33.8	22.9	41.8	26.5	SI6A361	4	50	1.9
EZ705B	140	3000	33.8	22.9	41.8	26.5	SI6A361	8	40	1.5
EZ705B	106	4500	27.7	25.4	39.4	32.8	SI6A361	4	50	1.5
EZ705B	106	4500	27.7	25.4	39.4	32.8	SI6A361	8	40	1.2
<b>EZ8</b>										
EZ813B	239	2000	57.3	21.9	61.6	22.9	SI6A262	4	25	1.1
EZ813B	239	2000	57.3	21.9	61.6	22.9	SI6A361	4	50	2.2
EZ813B	239	2000	57.3	21.9	61.6	22.9	SI6A361	8	40	1.8
EZ813B	117	4000	49.5	38.1	62.9	46.6	SI6A361	4	50	1.1
EZ815B	239	2000	91.0	33.7	100	36.3	SI6A361	4	50	1.4
EZ815B	239	2000	91.0	33.7	100	36.3	SI6A361	8	40	1.1

## 4.4 Accessories

You can find information about the available accessories in the following chapters.

### 4.4.1 Safety technology

#### Information

The drive controller is delivered in the standard design without safety technology (option SZ6). If you want a drive controller with integrated safety technology, you must order it together with the drive controller. The safety modules are an integrated part of the drive controllers and must not be modified.

#### SZ6 option – Without safety technology

ID No. 56660

Design without safety technology.

#### SX6 safety module – Extended safety technology using FSoE

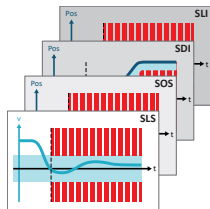

ID No. 5050185

Optional accessory for use in safety-related applications up to PL e, SIL 3 in accordance with EN ISO 13849-1 and EN 61800-5-2. In addition to the basic Safe Torque Off (STO) safety function, SX6 provides other safety functions specified in EN 61800-5-2. In addition to the safe stop functions Safe Stop 1 (SS1) and Safe Stop 2 (SS2), these also include Safely-Limited Speed (SLS), Safe Brake Control (SBC), Safe Brake Test (SBT), Safe Direction (SDI) and Safely-Limited Increment (SLI). Connection to the higher-level safety circuit using Fail Safe over EtherCAT (FSoE).

#### SR6 safety module – STO using terminals



ID No. 56661

Optional accessory for the use of the Safe Torque Off safety function (STO) in safety-relevant applications (PL e, SIL 3) in accordance with EN ISO 13849-1 and EN 61800-5-2. Connection to a higher-level safety circuit via terminal X12.

#### SY6 safety module – STO and SS1 using FSoE



ID No. 56662

Optional accessory for the use of the Safe Torque Off (STO) and Safe Stop 1 (SS1) safety functions in safety-relevant applications (PL e, SIL 3) in accordance with EN ISO 13849-1 and EN 61800-5-2. Connection to the higher-level safety circuit using Fail Safe over EtherCAT (FSoE).

#### SU6 safety module – STO and SS1 using PROFIsafe



ID No. 56696

Optional accessory for the use of the Safe Torque Off (STO) and Safe Stop 1 (SS1) safety functions in safety-relevant applications (PL e, SIL 3) in accordance with EN ISO 13849-1 and EN 61800-5-2. Connection to a higher-level safety circuit via PROFINET (PROFIsafe).

## 4.4.2 Communication

The drive controller has two interfaces for the EtherCAT or PROFINET connection on the top of the device as well as an Ethernet service interface on the front of the device. Cables for the connection are available separately.

### EtherCAT or PROFINET



Specify the desired fieldbus system when placing your order for the base device, since fieldbus communication is defined by the firmware.



### EtherCAT cables



Ethernet patch cable, CAT5e, yellow.

The following designs are available:

ID no. 49313: length approx. 0.25 m.

ID no. 49314: length approx. 0.5 m.

### PC connecting cable



ID No. 49857

Cable for connecting the X9 service interface to the PC, CAT5e, blue, length: 5 m.

### USB 2.0 Ethernet adapter



ID No. 49940

Adapter for connecting Ethernet to a USB port.

### 4.4.3 Terminal set

For the connection, you need suitable terminal sets for each PS6 supply module and each SI6 drive controller.

#### Terminal set for supply module

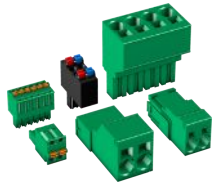

(Fig. similar)

The following designs are available:

ID No. 138660

Terminal set for PS6A24. Contents: 6 terminals.

ID No. 138661

Terminal set for PS6A34. Contents: 6 terminals.

ID No. 138679

Terminal set for PS6A44. Contents: 3 terminals.

#### Terminal set for drive controllers without SR6 safety module (STO using terminals)

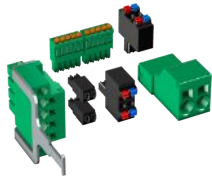

(Fig. similar)

The following designs are available:

ID No. 138655

Terminal set for SI6A061Z/U/Y/X. Contents: 9 terminals.

ID No. 138656

Terminal set for SI6A062Z/U/Y/X. Contents: 11 terminals.

ID No. 138657

Terminal set for SI6A161Z/U/Y/X. Contents: 9 terminals.

ID No. 138658

Terminal set for SI6A162Z/U/Y/X. Contents: 11 terminals.

ID No. 138659

Terminal set for SI6A261Z/U/Y/X. Contents: 9 terminals.

ID No. 138662

Terminal set for SI6A262Z/U/Y/X. Contents: 11 terminals.

ID No. 138663

Terminal set for SI6A361Z/U/Y/X. Contents: 9 terminals.

#### Terminal set for drive controllers with SR6 safety module (STO using terminals)

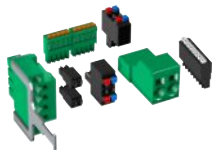

(Fig. similar)

The following designs are available:

ID No. 138683

Terminal set for SI6A061R. Contents: 10 terminals.

ID No. 138684

Terminal set for SI6A062R. Contents: 12 terminals.

ID No. 138685

Terminal set for SI6A161R. Contents: 10 terminals.

ID No. 138686

Terminal set for SI6A162R. Contents: 12 terminals.

ID No. 138687

Terminal set for SI6A261R. Contents: 10 terminals.

ID No. 138688

Terminal set for SI6A262R. Contents: 12 terminals.

ID No. 138689

Terminal set for SI6A361R. Contents: 10 terminals.

## 4.4.4 DC link connection

For the energy supply of the existing drive controllers in the group, you need suitable Quick DC-Link modules of type DL6B for each PS6 supply module and each SI6 drive controller.

For the horizontal connection, you receive DL6B rear section modules in various designs, matched to the size of the drive controller or supply module.

The quick fastening clamps for attaching the copper rails and an insulation connection piece are contained in the scope of delivery. The copper rails are not included in the scope of delivery. These must have a cross-section of 5 x 12 mm. Insulation end sections for the left and right termination of the device group as well as covers for the rear section modules are available separately. The covers protect rear section modules installed in the control cabinet that are only later built over with drive controllers or supply modules, for example as part of a retrofit.

### Quick DC-Link DL6B – rear section module for drive controller

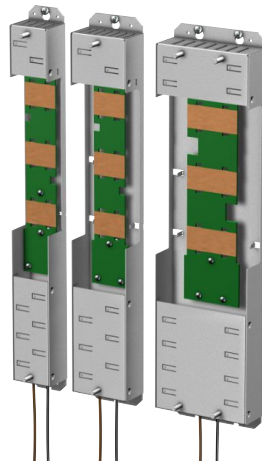

The following designs are available:

DL6B10

ID No. 56655

Rear section module for size 0 drive controller:

SI6A061 and SI6A062

DL6B11

ID No. 56656

Rear section module for size 1 or 2 (single-axis controller) drive controller:

SI6A161, SI6A162 and SI6A261

DL6B12

ID No. 56663

Rear section module for size 2 (double-axis controller) or 3 drive controller:

SI6A262 and SI6A361

### Quick DC-Link DL6B – rear section module for supply module

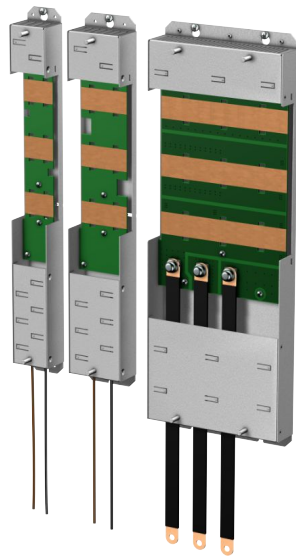

The following designs are available:

DL6B20

ID No. 56657

Rear section module for size 2 supply module:

PS6A24

DL6B21

ID No. 56658

Rear section module for size 3 supply module:

PS6A34

DL6B22

ID No. 5050114

Rear section module for size 4 supply module:

PS6A44

**Quick DC-Link DL6B – insulation end section**

ID No. 56659

Insulation end sections for the left and right termination of the group,  
2 pcs.**Quick DC-Link DL6B – cover**

The following designs are available:

QDL6C10

ID No. 5050128

Cover for DL6B10 or DL6B20 rear section module,  
Dimensions: 373 × 45 × 1 mm

QDL6C11

ID No. 5050129

Cover for DL6B11 or DL6B21 rear section module,  
Dimensions: 373 × 64 × 1 mm

QDL6C12

ID No. 5050130

Cover for DL6B12 rear section module,  
Dimensions: 373 × 105 × 1 mm

## 4.4.5 Braking resistor

In addition to the supply modules, STOBBER offers braking resistors in the various sizes and performance classes described below. For the selection, note the minimum permitted braking resistors specified in the technical data of the supply modules. In the event of a fault, such as a defective brake chopper, the supply module must be disconnected from the power supply.

### 4.4.5.1 Assignment of braking resistor – PS6

Type	KWADQU 420×91 with MWS306L	KWADQU 420×91 with MWS310L	FZZMQU 400×65	FGFKQU 31005	FGFKQU 31009	FGFKQU 31114
ID No.	138675	138676	56635	56636	5050115	5050116
PS6A24	(X)	X	X	X	—	—
PS6A34	(X)	X	X	X	—	—
PS6A44	(—)	(—)	(—)	(X)	X	X

Tab. 46: Braking resistor assignment to PS6 supply module

X	Recommended
(X)	Possible
(—)	Useful under certain conditions
—	Not possible

### 4.4.5.2 KWADQU flat resistor

The braking resistor is available with two different mounting bracket sets (MWS).

#### Properties

Technical data	KWADQU 420×91 with MWS306L	KWADQU 420×91 with MWS310L
ID No.	138675	138676
Type	Flat resistor with temperature switch (incl. mounting bracket)	
Resistance [ $\Omega$ ]	100 $\pm$ 10%	
Thermal drift	$\pm$ 10%	
Power [W]	600	
Thermal time constant $\tau_{th}$ [s]	60	
Pulse power for < 1 s [kW]	13	
$U_{max}$ [V]	848	
Cable design	FEP	
Cable length [mm]	500	
Conductor cross-section [AWG]	14/19 (1.9 mm <sup>2</sup> )	
Weight without packaging [g]	2620	2770
Protection class	IP54	
Marks and test symbols	cURus, CE, UKCA	

Tab. 47: KWADQU technical data

Technical data	Temperature switch
Switching capacity	2 A / 24 V <sub>DC</sub> (DC11)
Nominal response temperature $\vartheta_{NAT}$	180 °C $\pm$ 5 K
Type	NC
Cable design	FEP
Cable length [mm]	500
Conductor cross-section [AWG]	22

Tab. 48: Temperature switch technical data

**Dimensions**

**Braking resistor with MWS306L**

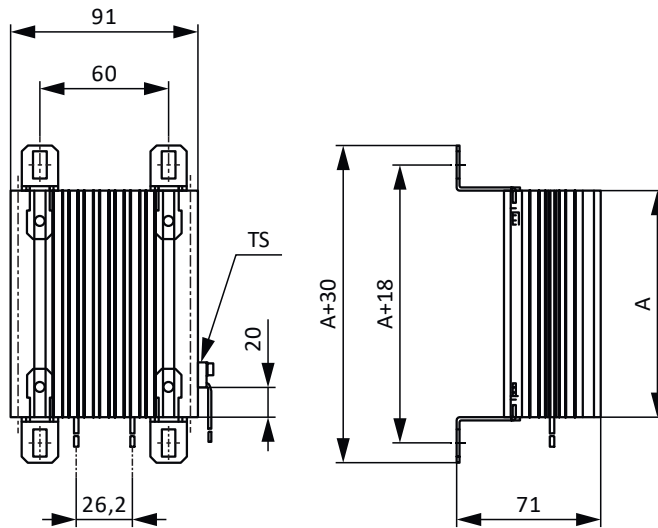

Fig. 9: KWADQU dimensional drawing with MWS306L

**Braking resistor with MWS310L**

The mounting brackets are freely positionable in the vertical direction over the entire length of the braking resistor.

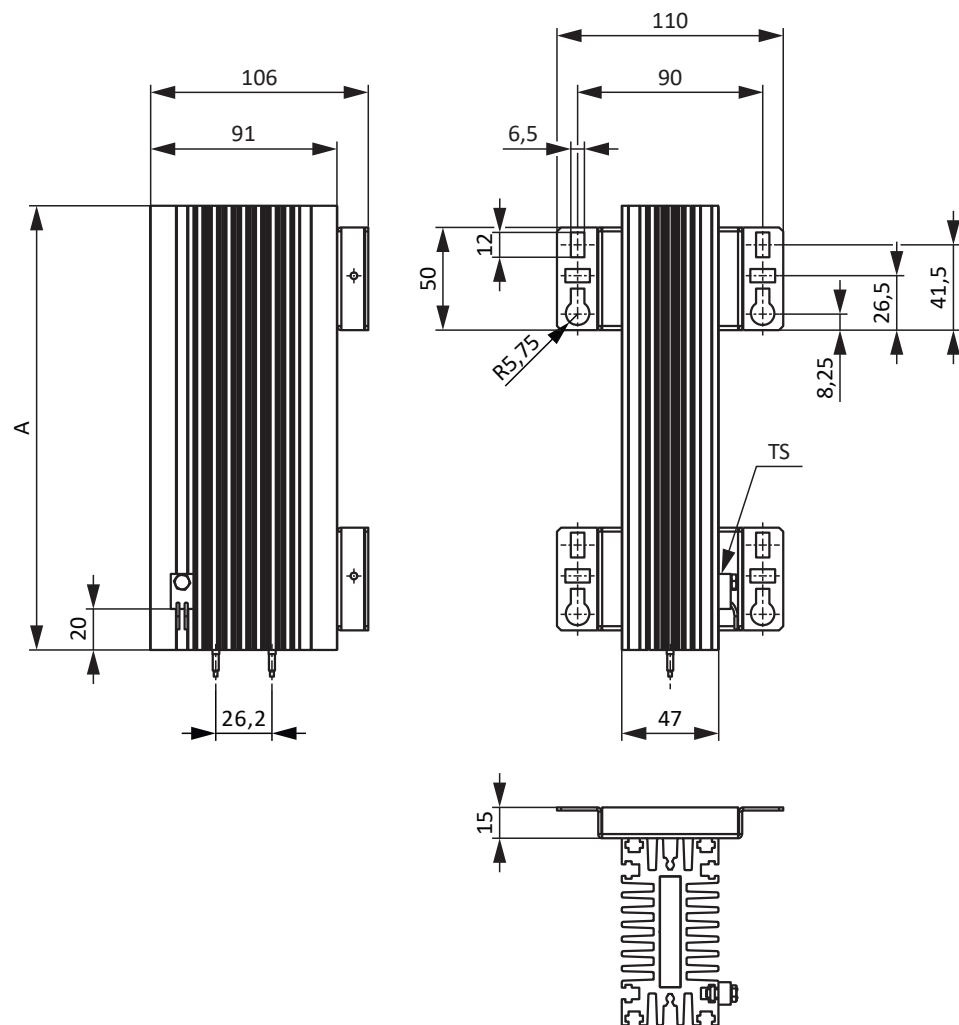

Fig. 10: KWADQU dimensional drawing with MWS310L

Dimension	KWADQU 420×91
A	420

Tab. 49: KWADQU dimensions [mm]

### 4.4.5.3 FZZMQU tubular fixed resistor

**Properties**

Technical data	FZZMQU 400×65
ID No.	56635
Type	Tubular fixed resistor with temperature switch
Resistance [Ω]	47 ±10%
Thermal drift	±10%
Power [W]	1200
Thermal time constant $\tau_{th}$ [s]	40
Pulse power for < 1 s [kW]	36
$U_{max}$ [V]	848
Weight without packaging [g]	4200
Protection class	IP20
Marks and test symbols	cURus, CE, UKCA

Tab. 50: FZZMQU technical data

Technical data	Temperature switch
Switching capacity	2 A / 24 V <sub>DC</sub> (DC11)
Nominal response temperature $\vartheta_{NAT}$	180 °C ± 5 K
Type	NC
Cable design	FEP
Cable length [mm]	500
Conductor cross-section [AWG]	22

Tab. 51: Temperature switch technical data

**Dimensions**

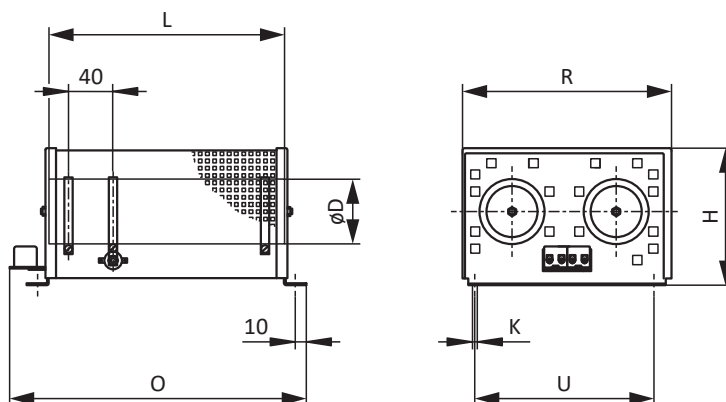

Fig. 11: FZZMQU dimensional drawing

Dimension	FZZMQU 400×65
L × D	400 × 65
H	120
K	6.5 × 12
O	485
R	185
U	150

Tab. 52: FZZMQU dimensions [mm]

#### 4.4.5.4 FGFKQU steel-grid fixed resistor

##### Properties

Technical data	FGFKQU 31005	FGFKQU 31009	FGFKQU 31114
ID No.	56636	5050115	5050116
Type	Steel-grid fixed resistor with temperature switch		
Resistance [ $\Omega$ ]	22 $\pm$ 10%	14.4 $\pm$ 10%	9.5 $\pm$ 10%
Thermal drift	$\pm$ 10%	$\pm$ 10%	$\pm$ 10%
Power [W]	2500	4500	7000
Thermal time constant $\tau_{th}$ [s]	30	30	20
Pulse power for < 1 s [kW]	50	90	140
$U_{max}$ [V]	848		
Weight without packaging [g]	7500	9500	13000
Protection class	IP20		
Marks and test symbols	cURus, CE, UKCA		

Tab. 53: FGFKQU technical data

Technical data	Temperature switch
Switching capacity	2 A / 24 V <sub>DC</sub> (DC11)
Nominal response temperature $\vartheta_{NAT}$	100 °C $\pm$ 5 K
Type	NC
Cable design	FEP
Cable length [mm]	500
Conductor cross-section [AWG]	22

Tab. 54: Temperature switch technical data

##### Dimensions

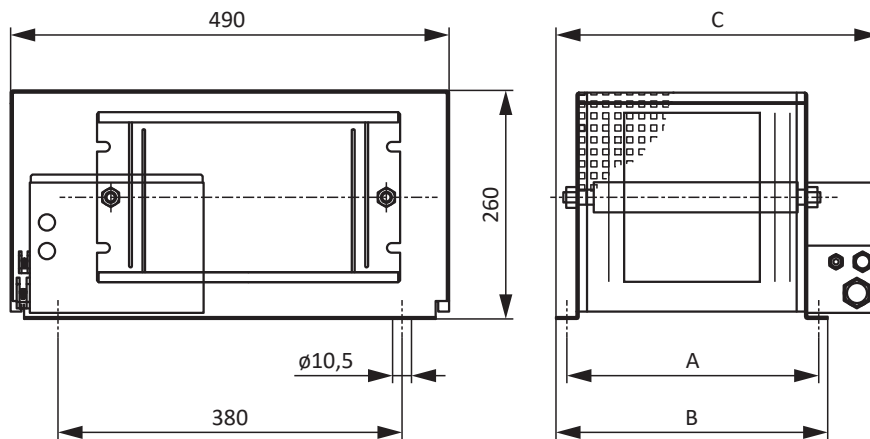

Fig. 12: FGFKQU dimensional drawing

Dimension	FGFKQU 31005	FGFKQU 31009	FGFKQU 31114
A	270	370	370
B	295	395	395
C	355	455	455

Tab. 55: FGFKQU dimensions [mm]

## 4.4.6 Choke

Technical specifications for suitable chokes can be found in the following chapters.

### 4.4.6.1 TEP power choke

Power chokes are used to dampen voltage and current peaks and reduce the load of the power feed-in of the supply modules.

#### Properties

Technical data	TEP4010-2US00
ID No.	56528
Phases	3
Thermally allowed continuous current	100 A
Nominal current $I_{N,MF}$	90 A
Absolute loss $P_V$	103 W
Inductance	0.14 mH
Voltage range	3 × 400 V <sub>AC</sub> +32%/-50% 3 × 480 V <sub>AC</sub> +10%/-58%
Voltage drop $U_k$	2%
Frequency range	50/60 Hz
Protection class	IP00
Max. surrounding temperature $\vartheta_{amb,max}$	40 °C
Insulation class	B
Connection	Screw terminal
Connection type	Flexible with and without end sleeve
Max. conductor cross-section	6 – 35 mm <sup>2</sup>
Tightening torque	2.5 Nm
Insulation stripping length	17 mm
Installation	Screws
Directive	EN 61558-2-20
UL Recognized Component (CAN; USA)	Yes
Marks and test symbols	cURus, CE

Tab. 56: TEP technical data

## Dimensions

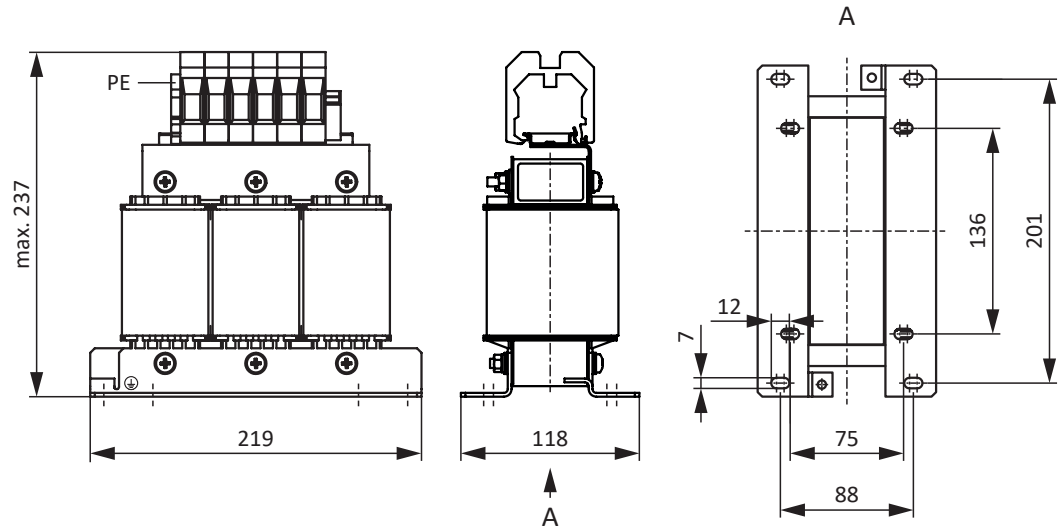

Fig. 13: Power choke dimensional drawing

Dimensions	TEP4010-2US00
Height [mm]	Max. 237
Width [mm]	219
Depth [mm]	118
Vertical distance 1 – Fastening bores [mm]	201
Vertical distance 2 – Fastening bores [mm]	136
Horizontal distance 1 – Fastening bores [mm]	88
Horizontal distance 2 – Fastening bores [mm]	75
Drill holes – Depth [mm]	7
Drill holes – Width [mm]	12
Screw connection – M	M6
Weight without packaging [g]	9900

Tab. 57: TEP dimensions and weight

### 4.4.6.2 TEP output choke

Output chokes are required for connecting size 0 to 2 drive controllers to synchronous servo motors or asynchronous motors from a cable length > 50 m in order to reduce interference pulses and protect the drive system. If Lean motors are connected, output chokes must not be used.

#### Information

The following technical data only applies to a rotating magnetic field frequency of 200 Hz. For example, this rotating magnetic field frequency is achieved with a motor with 4 pole pairs and a nominal speed of 3000 rpm. Always observe the specified derating for higher rotating magnetic field frequencies. Also observe the relationship with the clock frequency.

#### Properties

Technical data	TEP3720-0ES41	TEP3820-0CS41	TEP4020-0RS41
ID No.	53188	53189	53190
Voltage range	3 × 0 to 480 V <sub>AC</sub>		
Frequency range	0 – 200 Hz		
Nominal current I <sub>N,MF</sub> at 4 kHz	4 A	17.5 A	38 A
Nominal current I <sub>N,MF</sub> at 8 kHz	3.3 A	15.2 A	30.4 A
Max. permitted motor cable length with output choke	100 m		
Max. surrounding temperature $\vartheta_{amb,max}$	40 °C		
Protection class	IP00		
Winding losses	11 W	29 W	61 W
Iron losses	25 W	16 W	33 W
Connection	Screw terminal		
Max. conductor cross-section	10 mm <sup>2</sup>		
UL Recognized Component (CAN; USA)	Yes		
Marks and test symbols	cURus, CE		

Tab. 58: TEP technical data

## Dimensions

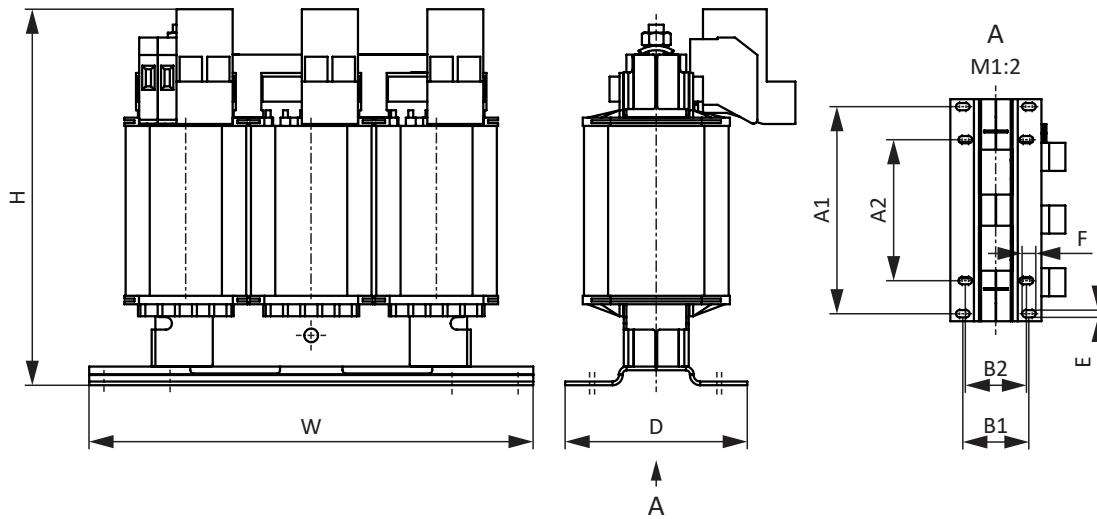

Fig. 14: TEP dimensional drawing

Dimension	TEP3720-0ES41	TEP3820-0CS41	TEP4020-0RS41
Height H [mm]	Max. 150	Max. 152	Max. 172
Width W [mm]	178	178	219
Depth D [mm]	73	88	119
Vertical distance – A1 fastening bores [mm]	166	166	201
Vertical distance – A2 fastening bores [mm]	113	113	136
Horizontal distance – B1 fastening bores [mm]	53	68	89
Horizontal distance – B2 fastening bores [mm]	49	64	76
Drill holes – Depth E [mm]	5.8	5.8	7
Drill holes – Width F [mm]	11	11	13
Screw connection – M	M5	M5	M6
Weight without packaging [g]	2900	5900	8800

Tab. 59: TEP dimensions and weight

## 4.4.7 HTL-to-TTL adapter

### HT6 HTL-to-TTL adapter



ID No. 56665

Adapters for SC6 and SI6 series drive controllers for level conversion from HTL signals to TTL signals.

It is used to connect an HTL differential incremental encoder to terminal X4 of the drive controller.

## 4.5 Further information

### 4.5.1 Directives and standards

The following European directives and standards are relevant to the drive controllers:

- Directive 2006/42/EC – Machinery Directive
- Directive 2014/30/EU – EMC Directive
- Directive 2011/65/EU – RoHS Directive
- Directive 2009/125/EC – Ecodesign Directive
- EN IEC 61800-3:2018
- EN 61800-5-1:2007 + A1:2017
- EN 61800-5-2:2017
- EN IEC 63000:2018
- EN ISO 13849-1:2015

### 4.5.2 Marks and test symbols

The following marks and test symbols are mentioned in the technical data.



**RoHS lead-free mark**

Marking in accordance with RoHS directive 2011-65-EU.



**CE mark**

Manufacturer's self declaration: The product meets the requirements of EU directives.



**UKCA test symbol**

Manufacturer's self declaration: The product meets the requirements of UK directives.



**UL test symbol (cULus)**

This product is listed by UL for the United States and Canada. Representative samples of this product have been evaluated by UL and meet the requirements of applicable standards.



**UL recognized component mark (cURus)**

This component or material is recognized by UL for the US and Canada. Representative samples of this product have been evaluated by UL and meet applicable requirements.

### 4.5.3 Additional documentation

Additional documentation related to the product can be found at

<http://www.stoeber.de/en/downloads/>

Enter the ID of the documentation in the Search term field.

Documentation	ID
Manual for SI6 drive controllers	442728

# 5 SD6 drive controllers

## Table of contents

5.1	Overview .....	118
5.1.1	Features.....	119
5.1.2	Software components .....	121
5.1.3	Application training.....	121
5.2	Technical data .....	122
5.2.1	Type designation .....	122
5.2.2	Sizes.....	122
5.2.3	General technical data .....	123
5.2.4	Electrical data.....	124
5.2.5	Cycle times .....	129
5.2.6	Derating.....	130
5.2.7	Dimensions.....	132
5.2.8	Weight.....	134
5.2.9	Minimum clearances .....	134
5.3	Drive controller/motor combinations.....	136
5.4	Accessories .....	142
5.4.1	Safety technology.....	142
5.4.2	Communication .....	143
5.4.3	Terminal module .....	144
5.4.4	DC link connection.....	146
5.4.5	Braking resistor .....	147
5.4.6	Choke .....	152
5.4.7	EMC shield plate.....	155
5.4.8	Encoder adapter box .....	155
5.4.9	Removable data storage .....	156
5.5	Further information .....	156
5.5.1	Directives and standards.....	156
5.5.2	Marks and test symbols .....	156
5.5.3	Additional documentation .....	156



## 5 Drive controllers

# SD6

### 5.1 Overview

The high performer for customized solutions

#### Features

- Nominal output current up to 85 A
- 250% overload capacity
- Control of rotary synchronous servo motors and asynchronous motors
- Control of linear and torque motors
- Multi-functional encoder interfaces
- Automatic motor parameterization from the electronic motor nameplate
- Isochronic system bus (IGB motion bus) for parameterization and multi-axis applications
- Communication over CANopen, EtherCAT or PROFINET
- Safe Torque Off (STO) in the standard version, extended safety technology (SS1, SS2, SLS, etc.) as an option
- Digital and analog inputs and outputs as an option
- Brake chopper, brake control and line filter
- Energy supply through direct power supply
- Flexible DC link connection for multi-axis applications
- Convenient operating unit consisting of graphical display and buttons
- Paramodul removable data storage for quick commissioning and service
- Available EPLAN macros in the EPLAN Data Portal

## 5.1.1 Features

Controlling servo axes precisely and quickly is its game. Due to its high computing power, the SD6 recalculates the position, speed and torque/force control of the servo axes every 62.5  $\mu\text{s}$ . This enables extraordinarily high dynamics and precision for the drives with very short recovery times and also fast reactions to set value changes and load jumps. The SD6 drive controller is available in four sizes with a nominal output current of up to 85 A. There is also an option of connecting the drive controllers in a DC link for multi-axis applications, which improves the energy footprint of the entire system.

For STOBBER synchronous servo motors, we recommended operation with EnDat 2.1/2.2 digital encoders. These encoder systems can deliver the highest control quality. It is possible to perform motor parameterization automatically from the electronic motor nameplate.



*SD6 drive controller*

### 32-bit Dual-Core

The control unit of the SD6 with a 32-bit dual-core processor opens up new dimensions in terms of precise movements and dynamics. The position, speed and torque control of the servo axes are calculated at a cycle time of 62.5  $\mu\text{s}$  (16 kHz). This ensures the shortest recovery times from fast changes in set values and load jumps.

### Play it safe with STOBBER

#### Integrated safety

STOBBER drive controllers have safety functions such as Safe Torque Off (STO) and Safe Stop 1 (SS1) that can be controlled either conventionally via terminals, or via the safe communication standards PROFIsafe (PROFINET) and Fail Safe over EtherCAT (FSOE). The fully electronic design works quickly and free of wear. Additional cyclical function tests are no longer necessary. This increases availability and reduces the amount of testing required during operation.

#### Extended safety

For stricter requirements, STOBBER offers optional safety functions up to SIL 3, PL e (category 4). These include functions such as Safely Limited Speed (SLS) for safe speed monitoring and Safe Operating Stop (SOS) to safely keep stopped axes in place, as well as Safe Brake Control (SBC) and Safe Brake Test (SBT) for reliable brake control and testing. Optimized monitoring mechanisms ensure short reaction times, minimum safety distances and increased system availability – for productive safety at the highest level.

### Quick DC-Link

All the product types of the SD6 drive controller have the option of a DC link connection. This technology makes it possible for the regenerative production of energy from one drive to be used as motor energy by another drive. The Quick DC-Link rear structure element has been developed to set up a reliable and efficient rail connection to the DC link connection. This optionally available accessory connects the DC links of the individual drive controllers by means of copper rails that can carry a load of up to 200 A. The rails can be attached without any tools using quick fastening clamps.

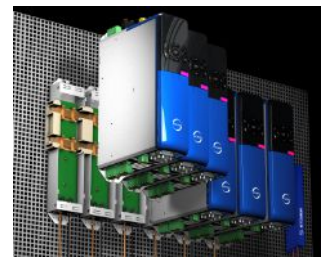

**Paramodul removable data storage**

Removable data storage with integrated microSD card is available for fast series commissioning by copying and for easy service when replacing devices. It represents the ideal medium for saving additional project data and documentation and can be used for direct editing on a PC.



**Integrated bus (IGB)**

SD6 drive controllers have two interfaces for the integrated bus in the standard version. The integrated bus is used for easy configuration over Ethernet and isochronic data exchange for the following functions:

- Multi-axis synchronization between the drive controllers (IGB motion bus)
- Direct connection for remote maintenance of individual and multiple drive controllers
- Direct connection between one or more drive controllers and a PC

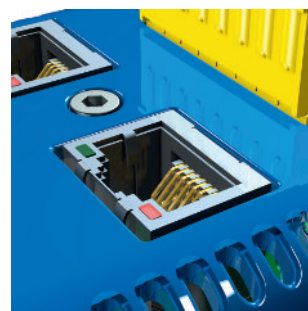

*Interface for the Integrated Bus*

**IGB motion bus**

The IGB motion bus allows for cyclic, isochronic data exchange between multiple SD6 drive controllers integrated into the IGB network. In addition to transferring guide values for master/slave operation, it is possible to exchange any other data as well.

**STOBER remote maintenance concept**

STOBER remote maintenance enables commissioning software to be used to perform all processes and sequences just like an on-site service visit. The concept guides users through a controlled and protected procedure. It ensures that the person responsible for the machine is there on site to pay attention to special situations and personal safety. On the other end, the remote maintenance specialist has the assurance of communicating with a responsible employee on site who is monitoring the situation on the machine.

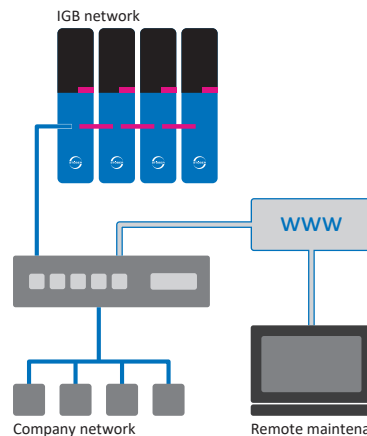

*Remote maintenance enables all processes and sequences to be performed just like an on-site service visit.*

## 5.1.2 Software components

### Project configuration and commissioning

The DriveControlSuite project configuration and commissioning software has all the functions for the efficient use of drive controllers in single-axis and multi-axis applications. The program guides you step by step through the complete project configuration and parameterization process using wizards.

### Open communication

Device communication is possible using EtherCAT, CANopen or PROFINET.

### Applications

A drive-based application is recommended for the decentralized motion control of sophisticated machines.

The drive-based application package from STOBBER is the right choice wherever universal and flexible solutions are needed. The Drive Based Synchronous application provides drive-based motion control for synchronous operation, positioning, velocity and torque/force with the PLCopen Motion Control command set. These standard commands have been combined into operating modes for different application cases and supplemented with additional functions such as motion block linking or cams. For the command operating mode, all properties of the movements are specified directly by the controller. The properties of the movements in the drive are predefined in the motion block operating mode so that only a start signal is necessary to perform the movement. Linking can be used to define complete motion sequences.

In addition, the CiA 402 application is also available, which includes both the controller-based and drive-based operating modes (csp, csv, cst, ip, pp, vl, pv, pt).

Furthermore, programming based on IEC 61131-3 with CFC can be used to create new applications or expand existing ones.

## 5.1.3 Application training

STOBBER offers a multi-level training program that is essentially focused on the drive controller.

### G6 Basic

Training content: System overview, installation and commissioning of the drive controller. Use of option modules. Parameterization, commissioning and diagnostics using the commissioning software. Remote maintenance. Basics of controller optimization. Configuration of the drive train. Integrated software functions. Software applications. Connection to a higher-level controller. Basics of safety technology. Practical exercises on training topics.

Software used: DriveControlSuite.

### G6 Customized

Training content: Special knowledge for regulating, control and safety technology. Practical exercises on training topics.

## 5.2 Technical data

Technical data for the drive controller can be found in the following chapters.

### 5.2.1 Type designation

SD	6	A	0	6	T	E	X
----	---	---	---	---	---	---	---

Tab. 1: Example code for type designation

Code	Designation	Design
SD	Series	
6	Generation	Generation 6
A, B	Version	
0 – 3	Size	
6 (0 – 9)	Power output stage	Power output stage within the size
T	Safety module	ST6: STO via terminals
E		SE6: Extended safety technology using terminals
N	Communication module	Empty
E		EC6: EtherCAT
C		CA6: CANopen
P		PN6: PROFINET
N	Terminal module	Empty
X		XI6: Extended
R		RI6: Resolver
I		IO6: Standard

Tab. 2: Meaning of the example code

### 5.2.2 Sizes

Type	Size
SD6A02	Size 0
SD6A04	Size 0
SD6A06	Size 0
SD6A14	Size 1
SD6A16	Size 1
SD6A24	Size 2
SD6A26	Size 2
SD6A34	Size 3
SD6A36	Size 3
SD6A38	Size 3

Tab. 3: Available SD6 types and sizes



SD6 in sizes 0, 1, 2 and 3

## 5.2.3 General technical data

The following information applies to all device types.

Device features	
Protection class of the device	IP20
Protection class of the installation space	At least IP54
Protection class	Protection class I in accordance with EN 61140
Radio interference suppression	Integrated line filter in accordance with EN 61800-3, interference emission class C3
Overvoltage category	III in accordance with EN 61800-5-1
Marks and test symbols	CE, cULus, RoHS

Tab. 4: Device features

Transport and storage conditions	
Storage/transport temperature	-20 °C to +70 °C Maximum change: 20 K/h
Relative humidity	Maximum relative humidity 85%, non-condensing
Vibration (transport) in accordance with EN 60068-2-6	5 Hz ≤ f ≤ 9 Hz: 3.5 mm 9 Hz ≤ f ≤ 200 Hz: 10 m/s <sup>2</sup> 200 Hz ≤ f ≤ 500 Hz: 15 m/s <sup>2</sup>
Fall height for free fall <sup>1</sup> Weight < 100 kg in accordance with EN 61800-2 (or IEC 60721-3-2, class 2M4)	0.25 m
Shock testing in accordance with EN 60068-2-27	Pulse shape: Half-sine Acceleration: 5 g Shock duration: 30 ms Number of shocks: 3 per axis

Tab. 5: Transport and storage conditions

Operating conditions	
Surrounding temperature during operation	0 °C to 45 °C with nominal data 45 °C to 55 °C with derating -2.5% / K
Relative humidity	Maximum relative humidity 85%, non-condensing
Installation altitude	0 m to 1000 m above sea level without restrictions 1000 m to 2000 m above sea level with -1.5%/100 m derating
Pollution degree	Pollution degree 2 in accordance with EN 50178
Ventilation	Installed fan
Vibration (operation) in accordance with EN 60068-2-6	5 Hz ≤ f ≤ 9 Hz: 0.35 mm 9 Hz ≤ f ≤ 200 Hz: 1 m/s <sup>2</sup>

Tab. 6: Operating conditions

Discharge times	
Self-discharge of DC link	6 min

Tab. 7: Discharge times of the DC link circuit

<sup>1</sup>Only valid for components in their original packaging.

## 5.2.4 Electrical data

The electrical data of the available sizes as well as the properties of the brake chopper can be found in the following chapters.

An explanation of the symbols used for formulas can be found in Chapter [\[ 9.1 \]](#).

### 5.2.4.1 Control unit

Electrical data	All types
$U_{1CU}$	$24 V_{DC}$ , +20%/–15%
$I_{1maxCU}$	1.5 A

Tab. 8: Control unit electrical data

### 5.2.4.2 Power unit: Size 0

Electrical data	SD6A02	SD6A04	SD6A06
$U_{1PU}$	$1 \times 230 V_{AC}$ , +20% / –40%, 50/60 Hz	$3 \times 400 V_{AC}$ , +32% / –50%, 50/60 Hz; $3 \times 480 V_{AC}$ , +10% / –58%, 50/60 Hz	
$f_{2PU}$	0 – 700 Hz		
$U_{2PU}$	0 – max. $U_{1PU}$		
$U_{2PU,ZK}$	$\sqrt{2} \times U_{1PU}$		
$C_{PU}$	340 $\mu F$	135 $\mu F$	135 $\mu F$
$C_{N,PU}$	1620 $\mu F$	540 $\mu F$	540 $\mu F$

Tab. 9: SD6 electrical data, size 0

#### Nominal currents up to +45 °C (in the control cabinet)

Electrical data	SD6A02	SD6A04	SD6A06
$f_{PWM,PU}$	4 kHz		
$I_{1N,PU}$	8.3 A	2.8 A	5.4 A
$I_{2N,PU}$	4 A	2.3 A	4.5 A
$I_{2maxPU}$	180% for 5 s; 150% for 30 s		

Tab. 10: SD6 electrical data, size 0, for 4 kHz clock frequency

Electrical data	SD6A02	SD6A04	SD6A06
$f_{PWM,PU}$	8 kHz		
$I_{1N,PU}$	6 A	2.2 A	4 A
$I_{2N,PU}$	3 A	1.7 A	3.4 A
$I_{2maxPU}$	250% for 2 s; 200% for 5 s		

Tab. 11: SD6 electrical data, size 0, for 8 kHz clock frequency

Electrical data	SD6A02	SD6A04	SD6A06
$U_{onCH}$	400 – 420 $V_{DC}$	780 – 800 $V_{DC}$	
$U_{offCH}$	360 – 380 $V_{DC}$	740 – 760 $V_{DC}$	
$R_{2minRB}$	100 $\Omega$		
$P_{maxRB}$	1.8 kW	6.4 kW	
$P_{effRB}$	1.0 kW	2.9 kW	

Tab. 12: Brake chopper electrical data, size 0

## 5.2.4.3 Power unit: Size 1

Electrical data	SD6A14	SD6A16
$U_{1PU}$	3 × 400 V <sub>AC</sub> , +32% / -50%, 50/60 Hz; 3 × 480 V <sub>AC</sub> , +10% / -58%, 50/60 Hz	
$f_{2PU}$	0 – 700 Hz	
$U_{2PU}$	0 – max. $U_{1PU}$	
$U_{2PU,ZK}$	$\sqrt{2} \times U_{1PU}$	
$C_{PU}$	470 μF	560 μF
$C_{N,PU}$	1400 μF	1400 μF

Tab. 13: SD6 electrical data, size 1

## Nominal currents up to +45 °C (in the control cabinet)

Electrical data	SD6A14	SD6A16
$f_{PWM,PU}$	4 kHz	
$I_{1N,PU}$	12 A	19.2 A
$I_{2N,PU}$	10 A	16 A
$I_{2maxPU}$	180% for 5 s; 150% for 30 s	

Tab. 14: SD6 electrical data, size 1, for 4 kHz clock frequency

Electrical data	SD6A14	SD6A16
$f_{PWM,PU}$	8 kHz	
$I_{1N,PU}$	9.3 A	15.8 A
$I_{2N,PU}$	6 A	10 A
$I_{2maxPU}$	250% for 2 s; 200% for 5 s	

Tab. 15: SD6 electrical data, size 1, for 8 kHz clock frequency

Electrical data	SD6A14	SD6A16
$U_{onCH}$	780 – 800 V <sub>DC</sub>	
$U_{offCH}$	740 – 760 V <sub>DC</sub>	
$R_{2minRB}$	47 Ω	
$P_{maxRB}$	13.6 kW	
$P_{effRB}$	6.2 kW	

Tab. 16: Brake chopper electrical data, size 1

## 5.2.4.4 Power unit: Size 2

Electrical data	SD6A24	SD6A26
$U_{1PU}$	3 × 400 V <sub>AC</sub> , +32% / -50%, 50/60 Hz; 3 × 480 V <sub>AC</sub> , +10% / -58%, 50/60 Hz	
$f_{2PU}$	0 – 700 Hz	
$U_{2PU}$	0 – max. $U_{1PU}$	
$U_{2PU,ZK}$	$\sqrt{2} \times U_{1PU}$	
$C_{PU}$	680 μF	1000 μF
$C_{N,PU}$	1400 μF	1400 μF

Tab. 17: SD6 electrical data, size 2

## Nominal currents up to +45 °C (in the control cabinet)

Electrical data	SD6A24	SD6A26
$f_{PWM,PU}$	4 kHz	
$I_{1N,PU}$	26.4 A	38.4 A
$I_{2N,PU}$	22 A	32 A
$I_{2maxPU}$	180% for 5 s; 150% for 30 s	

Tab. 18: SD6 electrical data, size 2, for 4 kHz clock frequency

Electrical data	SD6A24	SD6A26
$f_{PWM,PU}$	8 kHz	
$I_{1N,PU}$	24.5 A	32.6 A
$I_{2N,PU}$	14 A	20 A
$I_{2maxPU}$	250% for 2 s; 200% for 5 s	

Tab. 19: SD6 electrical data, size 2, for 8 kHz clock frequency

Electrical data	SD6A24	SD6A26
$U_{onCH}$	780 – 800 V <sub>DC</sub>	
$U_{offCH}$	740 – 760 V <sub>DC</sub>	
$R_{2minRB}$	22 Ω	
$P_{maxRB}$	29.1 kW	
$P_{effRB}$	13.2 kW	

Tab. 20: Brake chopper electrical data, size 2

## 5.2.4.5 Power unit: Size 3

Electrical data	SD6A34	SD6A36	SD6A38
$U_{1PU}$	3 × 400 V <sub>AC</sub> , +32% / -50%, 50/60 Hz; 3 × 480 V <sub>AC</sub> , +10% / -58%, 50/60 Hz		
$f_{2PU}$	0 – 700 Hz		
$U_{2PU}$	0 – max. $U_{1PU}$		
$U_{2PU,ZK}$	$\sqrt{2} \times U_{1PU}$		
$C_{PU}$	430 μF	900 μF	900 μF
$C_{N,PU}$	5100 μF	5100 μF	5100 μF

Tab. 21: SD6 electrical data, size 3

## Nominal currents up to +45 °C (in the control cabinet)

Electrical data	SD6A34	SD6A36	SD6A38
$f_{PWM,PU}$	4 kHz		
$I_{1N,PU}$	45.3 A	76 A	76 A
$I_{2N,PU}$	44 A	70 A	85 A <sup>2</sup>
$I_{2maxPU}$	180% for 5 s; 150% for 30 s UL: 200% for 3 s		180% for 5 s; 150% for 10 s UL: 200% for 3 s

Tab. 22: SD6 electrical data, size 3, for 4 kHz clock frequency

Electrical data	SD6A34	SD6A36	SD6A38
$f_{PWM,PU}$	8 kHz		
$I_{1N,PU}$	37 A	62 A	76 A
$I_{2N,PU}$	30 A	50 A	60 A
$I_{2maxPU}$	250% for 2 s; 200% for 5 s UL: 200% for 3 s		

Tab. 23: SD6 electrical data, size 3, for 8 kHz clock frequency

Electrical data	SD6A34	SD6A36	SD6A38
$U_{onCH}$	780 – 800 V <sub>DC</sub>		
$U_{offCH}$	740 – 760 V <sub>DC</sub>		
$R_{intRB}$	30 Ω (PTC resistance; 100 W; max. 1 kW for 1 s; τ = 40 s)		
$R_{2minRB}$	15 Ω		
$P_{maxRB}$	42 kW		
$P_{effRB}$	19.4 kW		

Tab. 24: Brake chopper electrical data, size 3

<sup>2</sup> Specification applies to the default value of the field weakening voltage limit: B92 = 80%.

### 5.2.4.6 DC link connection

The charging capacity of the drive controllers can be increased by a DC link connection only if the power supply is connected to all drive controllers simultaneously.

### 5.2.4.7 Power loss data in accordance with EN 61800-9-2

Type	Nominal current $I_{2N,PU}$	Apparent power	Absolute losses $P_{V,CU}$ <sup>3</sup>	Operating points <sup>4</sup>								IE class <sup>5</sup>	Comparison <sup>6</sup>
				(0/25)	(0/50)	(0/100)	(50/25)	(50/50)	(50/100)	(90/50)	(90/100)		
				Relative losses									
				[%]									
	[A]	[kVA]	[W]										
SD6A02	4	0.9	10	5.01	5.07	5.68	5.20	5.37	6.30	5.88	7.43	IE2	
SD6A04	2.3	1.6	10	2.98	3.13	3.49	3.02	3.22	3.71	3.36	4.09	IE2	
SD6A06	4.5	3.1	12	1.71	1.86	2.24	1.75	1.97	2.51	2.16	3.04	IE2	
SD6A14	10	6.9	12	1.38	1.54	1.93	1.43	1.64	2.17	1.80	2.57	IE2	
SD6A16	16	11.1	12	0.95	1.12	1.66	0.99	1.23	1.98	1.41	2.52	IE2	
SD6A24	22	15.2	15	0.80	0.97	1.49	0.84	1.06	1.75	1.21	2.19	IE2	
SD6A26	32	22.2	15	0.70	0.87	1.40	0.74	0.97	1.67	1.11	2.10	IE2	
SD6A34	44	30.5	35	0.61	0.76	1.21	0.68	0.90	1.53	1.06	1.96	IE2	
SD6A36	70	48.5	35	0.53	0.69	1.18	0.59	0.82	1.49	0.97	1.89	IE2	
SD6A38	85	58.9	35	0.47	0.64	1.18	0.54	0.78	1.50	0.94	1.94	IE2	
				Absolute losses									
				$P_V$									
	[A]	[kVA]	[W]	[W]									[%]
SD6A02	4	0.9	10	45.1	45.6	51.1	46.8	48.3	56.7	52.9	66.9	IE2	51.8
SD6A04	2.3	1.6	10	47.7	50.1	55.8	48.3	51.5	59.3	53.8	65.4	IE2	40.2
SD6A06	4.5	3.1	12	52.9	57.6	69.3	54.4	61.0	77.9	67.1	94.1	IE2	39.6
SD6A14	10	6.9	12	95.3	106.1	133.3	98.6	113.2	149.9	123.9	177.0	IE2	37.1
SD6A16	16	11.1	12	104.9	124.0	184.6	110.3	136.6	219.8	156.0	279.8	IE2	35.8
SD6A24	22	15.2	15	121.5	146.9	226.1	128.1	161.6	266.0	183.7	332.7	IE2	32.9
SD6A26	32	22.2	15	154.7	192.8	311.3	164.7	214.9	370.5	246.9	465.9	IE2	38.6
SD6A34	44	30.5	35	187.5	232.2	368.7	207.7	273.9	466.8	323.0	597.8	IE2	32.1
SD6A36	70	48.5	35	256.6	332.3	570.8	287.9	397.0	721.5	471.0	915.9	IE2	33.9
SD6A38	85	58.9	35	277.8	376.9	692.3	317.4	459.0	886.1	554.6	1143.1	IE2	35.3

Tab. 25: Power loss data of the SD6 drive controller in accordance with EN 61800-9-2

#### General conditions

The power loss data applies to drive controllers without accessories.

The power loss calculation is based on a 3-phase supply voltage with 400 V<sub>ac</sub>/50 Hz.

The calculated data includes a supplement of 10% in accordance with EN 61800-9-2.

The power loss specifications refer to a clock frequency of 4 kHz.

The absolute losses for a power unit that is switched off refer to the 24 V<sub>dc</sub> power supply of the control electronics.

<sup>3</sup> Absolute losses for a power unit that is switched off

<sup>4</sup> Operating points for relative motor stator frequency in % and relative torque current in %

<sup>5</sup> IE class in accordance with EN 61800-9-2

<sup>6</sup> Comparison of the losses for the reference related to IE2 in the nominal point (90, 100)

### 5.2.4.8 Power loss data of accessories

If you intend to order the drive controller with accessory parts, losses increase as follows:

Type	Absolute losses $P_v$ [W]
SE6 safety module	< 4
ST6 safety module	1
IO6 terminal module	< 2
XI6 or RI6 terminal module	< 5
CA6 communication module	1
EC6 communication module	< 2
PN6 communication module	< 4

Tab. 26: Absolute losses of the accessories

#### Information

Note the absolute power loss of the encoder (usually < 3 W) and of the brake when designing as well.

Loss specifications for other optional accessories can be found in the technical data of the respective accessory part.

### 5.2.5 Cycle times

Possible cycle times can be found in the following table.

Type	Cycle times	Relevant parameters
Application	1 ms, 2 ms, 4 ms, 8 ms	Adjustable in A150
EtherCAT fieldbus, cyclical communication	1 ms, 2 ms, 4 ms, 8 ms	Adjustable in TwinCAT 3 or CODESYS
PROFINET RT fieldbus, cyclical communication	1 ms, 2 ms, 4 ms, 8 ms	Adjustable in the TIA Portal
Motion core (movement calculation)	250 $\mu$ s	—
Control cascade	62.5 $\mu$ s	B24 $\geq$ 8 kHz and B20 = 48, 64 or 70
	125 $\mu$ s	B24 = 4 kHz

Tab. 27: Cycle times

## 5.2.6 Derating

When dimensioning the drive controller, observe the derating of the nominal output current as a function of the clock frequency, surrounding temperature and installation altitude. There is no restriction for a surrounding temperature from 0 °C to 45 °C and an installation altitude of 0 m to 1000 m. The details given below apply to values outside these ranges.

### 5.2.6.1 Effect of the clock frequency

Changing the clock frequency  $f_{\text{PWM}}$  affects the amount of noise produced by the drive, among other things. However, increasing the clock frequency results in increased losses. During project configuration, define the highest clock frequency and use it to determine the nominal output current  $I_{2\text{N,PU}}$  for dimensioning the drive controller.

Type	$I_{2\text{N,PU}}$ 4 kHz	$I_{2\text{N,PU}}$ 8 kHz	$I_{2\text{N,PU}}$ 16 kHz
SD6A02	4 A	3 A	2 A
SD6A04	2.3 A	1.7 A	1.1 A
SD6A06	4.5 A	3.4 A	2.3 A
SD6A14	10 A	6 A	4 A
SD6A16	16 A	10 A	5.7 A
SD6A24	22 A	14 A	8.1 A
SD6A26	32 A	20 A	12 A
SD6A34	44 A	30 A	18 A
SD6A36	70 A	50 A	31 A
SD6A38	85 A <sup>7</sup>	60 A	37.8 A

Tab. 28: Nominal output current  $I_{2\text{N,PU}}$  dependent on the clock frequency

### 5.2.6.2 Effect of the installation altitude

Derating as a function of the installation altitude is determined as follows:

- 0 m to 1000 m: No restriction ( $D_{\text{IA}} = 100\%$ )
- 1000 m to 2000 m: Derating  $-1.5\%/100$  m

#### Example

The drive controller needs to be installed at an altitude of 1500 m above sea level.

The derating factor  $D_{\text{IA}}$  is calculated as follows:

$$D_{\text{IA}} = 100\% - 5 \times 1.5\% = 92.5\%$$

### 5.2.6.3 Effect of the surrounding temperature

Derating as a function of the surrounding temperature is determined as follows:

- 0 °C to 45 °C: No restrictions ( $D_{\text{T}} = 100\%$ )
- 45 °C to 55 °C: Derating  $-2.5\%/K$

#### Example

The drive controller needs to be operated at 50 °C.

The derating factor  $D_{\text{T}}$  is calculated as follows

$$D_{\text{T}} = 100\% - 5 \times 2.5\% = 87.5\%$$

### 5.2.6.4 Calculating the derating

Follow these steps for the calculation:

1. Determine the highest clock frequency ( $f_{\text{PWM}}$ ) that will be used during operation and use it to determine the nominal current  $I_{2\text{N,PU}}$ .
2. Determine the derating factors for installation altitude and surrounding temperature.
3. Calculate the reduced nominal current  $I_{2\text{N,PU(red)}}$  in accordance with the following formula:

$$I_{2\text{N,PU(red)}} = I_{2\text{N,PU}} \times D_T \times D_{\text{IA}}$$

#### Example

A drive controller of type SD6A06 needs to be operated at a clock frequency of 8 kHz at an altitude of 1500 m above sea level and a surrounding temperature of 50 °C.

The nominal current of the SD6A06 at 8 kHz is 3.4 A. The derating factor  $D_T$  is calculated as follows:

$$D_T = 100\% - 5 \times 2.5\% = 87.5\%$$

The derating factor  $D_{\text{IA}}$  is calculated as follows:

$$D_{\text{IA}} = 100\% - 5 \times 1.5\% = 92.5\%$$

The output current of importance for the project configuration is:

$$I_{2\text{N,PU(red)}} = 3.4 \text{ A} \times 0.875 \times 0.925 = 2.75 \text{ A}$$

## 5.2.7 Dimensions

The dimensions of the available SD6 sizes can be found in the following chapters.

### 5.2.7.1 Dimensions: sizes 0 to 2

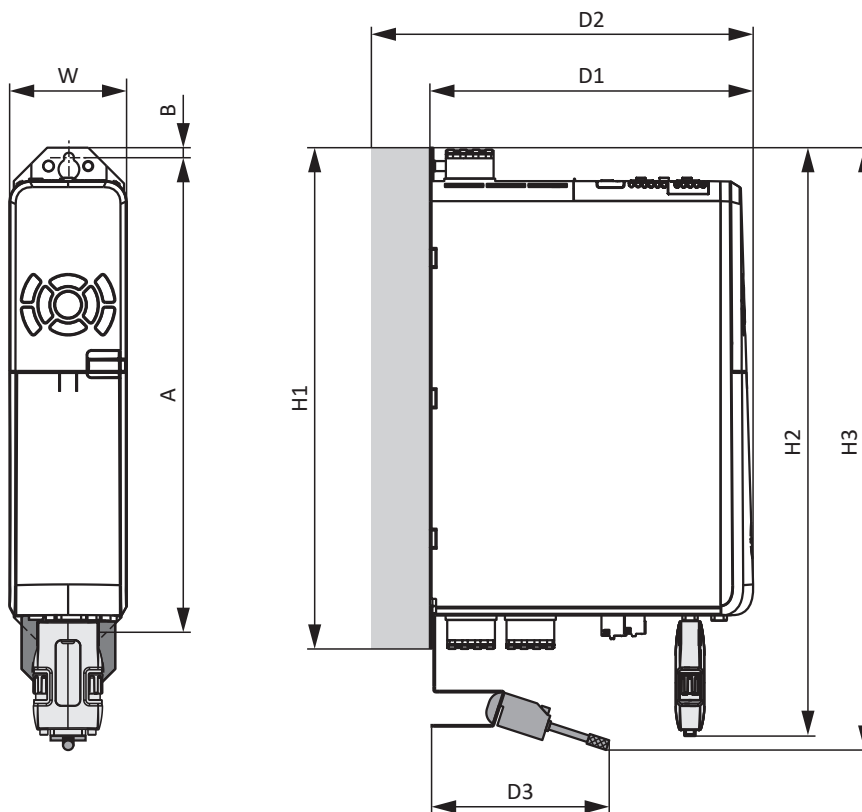

Fig. 1: SD6 dimensional drawing, sizes 0 to 2

Dimension			Size 0	Size 1	Size 2
Drive controller	Width	W	70	70	105
	Depth	D1	194	284	
	Depth incl. RB 5000 braking resistor	D2	212	302	
	Depth incl. Quick DC-Link	D2	229	319	
	Height incl. fastening clips	H1		300	
	Height incl. AES	H2		360	
	Height incl. EMC shield plate	H3		360	
EMC shield plate incl. shield connection terminal	Depth	D3	approx. 111		
Fastening bores	Vertical distance	A	283+2		
	Vertical distance to the upper edge	B	6		

Tab. 29: SD6 dimensions, sizes 0 to 2 [mm]

## 5.2.7.2 Dimensions: size 3

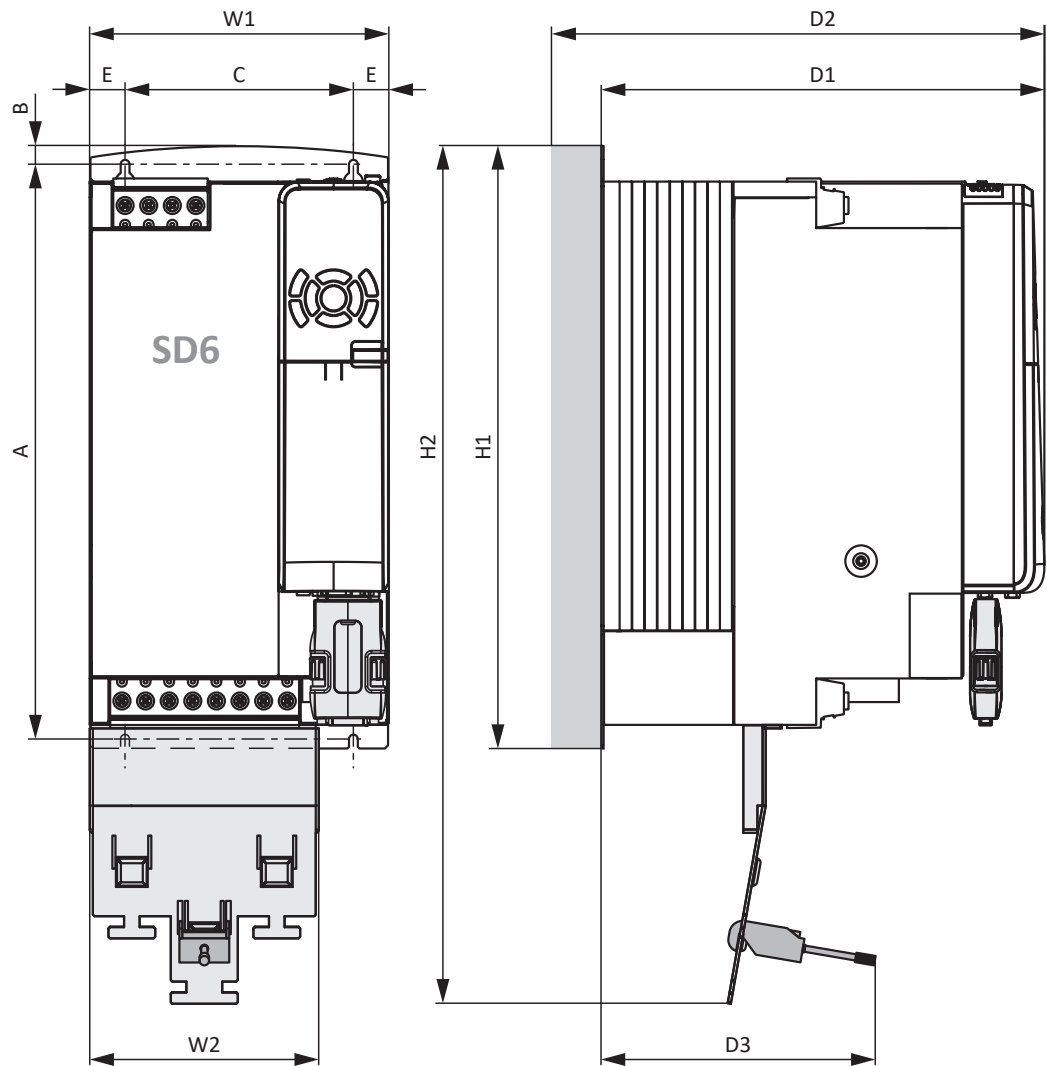

Fig. 2: SD6 dimensional drawing, size 3

Dimension		Size 3	
Drive controller	Width	W1	190
	Depth	D1	305
	Depth incl. Quick DC-Link	D2	340
	Height incl. fastening clips	H1	382.5
	Height incl. EMC shield plate	H2	540
EMC shield plate incl. shield connection terminal	Width	W2	147
	Depth	D3	approx. 174
Fastening bores	Vertical distance	A	365+2
	Vertical distance to the upper edge	B	11.5
	Horizontal distance of the fastening bores of the drive controller	C	150+0.2/-0.2
	Horizontal distance to the side edge of the drive controller	E	20

Tab. 30: SD6 dimensions, size 3 [mm]

### 5.2.8 Weight

Size	Weight without packaging [g]	Weight with packaging [g]
Size 0	2530	3520
Size 1	3700	5470
Size 2	5050	6490
Size 3	13300	14800

Tab. 31: SD6 weight [g]

If you intend to order the drive controller with accessory parts, the weight increases as follows.

Accessories	Weight without packaging [g]
Communication module	50
Terminal module	135
Safety module	110

Tab. 32: Weight of the accessory part [g]

### 5.2.9 Minimum clearances

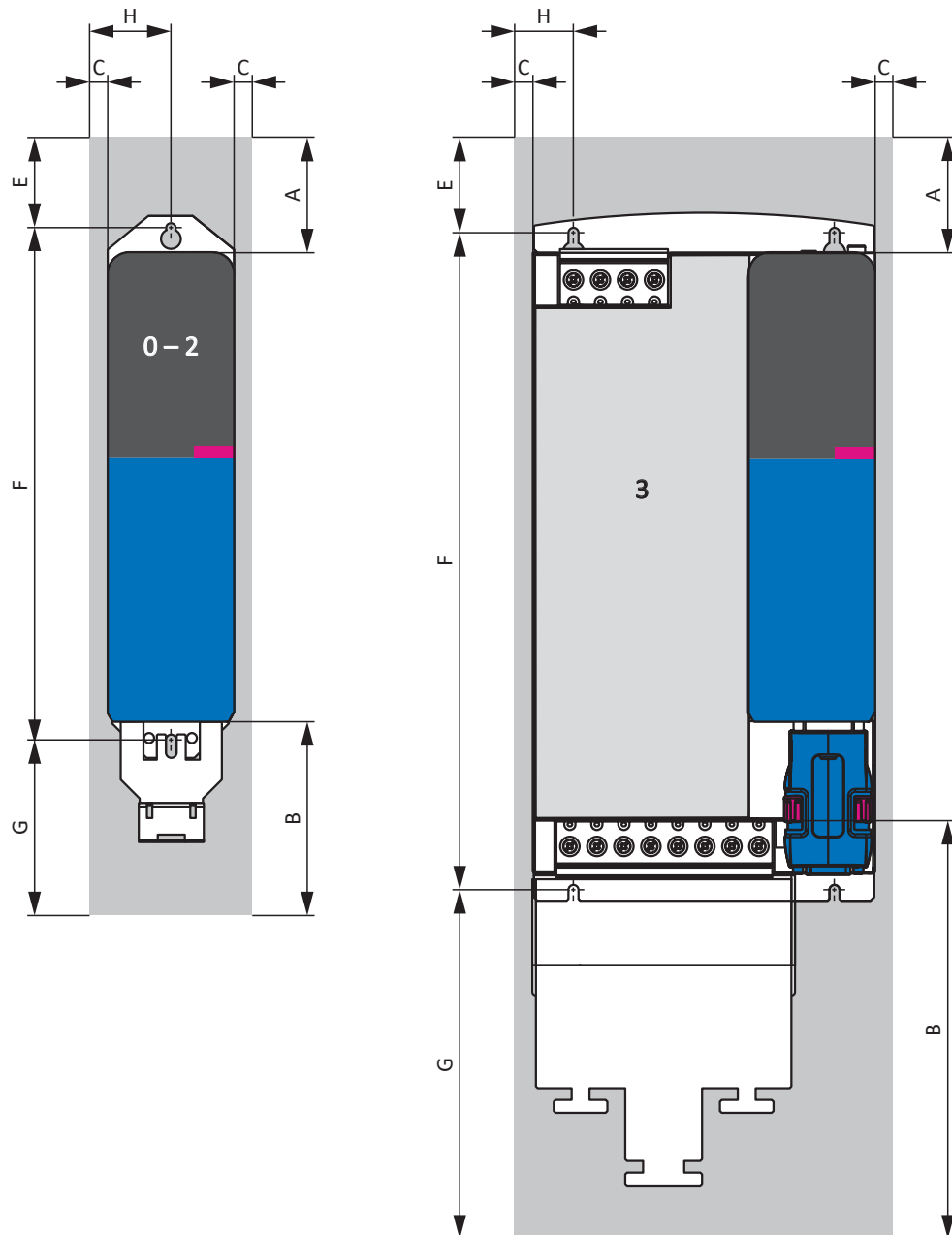

Fig. 3: Minimum clearances

The dimensions specified in the table relate to the outer edges of the drive controller.

Minimum clearance	A (above)	B (below)	C (one the side) <sup>8</sup>
Size 0 – Size 2	100	100	5
... with EMC shield plate	100	120	5
Size 3	100	100	5
... with EMC shield plate	100	220	5

Tab. 33: Minimum clearances [mm]

Dimension	E	F	G	H
Size 0, size 1	86	283+2	approx. 89	40
... with EMC shield plate	86	283+2	approx. 109	40
Size 2	86	283+2	approx. 89	57.5
... with EMC shield plate	86	283+2	approx. 109	57.5
Size 3	89	365+2	approx. 59.5	25
... with EMC shield plate	89	365+2	approx. 179.5	25

Tab. 34: Dimensions [mm]

#### Chokes and filters

Avoid installation below drive controllers or supply modules. For installation in a control cabinet, a distance of approximately 100 mm to other neighboring components is recommended. This distance ensures proper heat dissipation for chokes and filters.

#### Braking resistors

Avoid installation below drive controllers or supply modules. In order for heated air to flow out unimpeded, a minimum clearance of approximately 200 mm must be maintained in relation to neighboring components or walls and approximately 300 mm must be maintained to components above or ceilings.

<sup>8</sup> Installation without Quick DC-Link module

## 5.3 Drive controller/motor combinations

An explanation of the symbols used for formulas can be found in Chapter [9.1](#).

### IC 410 convection cooling

Type	$K_{EM}$ [V/1000 min <sup>-1</sup> ]	$n_N$ [rpm]	$M_N$ [Nm]	$I_N$ [A]	$M_0$ [Nm]	$I_0$ [A]	Type	$f_{PWM,PU}$ [kHz]	$I_{2N,PU}$ [A]	$I_{2N,PU}/I_0$
<b>EZ2</b>										
EZ202U	40	6000	0.40	0.99	0.44	1.03	SD6A04	4	2.3	2.2
EZ202U	40	6000	0.40	0.99	0.44	1.03	SD6A04	8	1.7	1.7
EZ203U	40	6000	0.61	1.54	0.69	1.64	SD6A04	4	2.3	1.4
EZ203U	40	6000	0.61	1.54	0.69	1.64	SD6A04	8	1.7	1.0
EZ203U	40	6000	0.61	1.54	0.69	1.64	SD6A06	4	4.5	2.7
EZ203U	40	6000	0.61	1.54	0.69	1.64	SD6A06	8	3.4	2.1
<b>EZ3</b>										
EZ301U	40	3000	0.93	1.99	0.95	2.02	SD6A04	4	2.3	1.1
EZ301U	40	3000	0.93	1.99	0.95	2.02	SD6A06	4	4.5	2.2
EZ301U	40	3000	0.93	1.99	0.95	2.02	SD6A06	8	3.4	1.7
EZ301U	40	3000	0.93	1.99	0.95	2.02	SD6A14	8	6	3.0
EZ301U	40	6000	0.89	1.93	0.95	2.02	SD6A04	4	2.3	1.1
EZ301U	40	6000	0.89	1.93	0.95	2.02	SD6A06	4	4.5	2.2
EZ301U	40	6000	0.89	1.93	0.95	2.02	SD6A06	8	3.4	1.7
EZ301U	40	6000	0.89	1.93	0.95	2.02	SD6A14	8	6	3.0
EZ302U	86	3000	1.59	1.60	1.68	1.67	SD6A04	4	2.3	1.4
EZ302U	86	3000	1.59	1.60	1.68	1.67	SD6A04	8	1.7	1.0
EZ302U	86	3000	1.59	1.60	1.68	1.67	SD6A06	4	4.5	2.7
EZ302U	86	3000	1.59	1.60	1.68	1.67	SD6A06	8	3.4	2.0
EZ302U	42	6000	1.50	3.18	1.68	3.48	SD6A06	4	4.5	1.3
EZ302U	42	6000	1.50	3.18	1.68	3.48	SD6A14	4	10	2.9
EZ302U	42	6000	1.50	3.18	1.68	3.48	SD6A14	8	6	1.7
EZ302U	42	6000	1.50	3.18	1.68	3.48	SD6A16	8	10	2.9
EZ303U	109	3000	2.07	1.63	2.19	1.71	SD6A04	4	2.3	1.4
EZ303U	109	3000	2.07	1.63	2.19	1.71	SD6A06	4	4.5	2.6
EZ303U	109	3000	2.07	1.63	2.19	1.71	SD6A06	8	3.4	2.0
EZ303U	55	6000	1.96	3.17	2.25	3.55	SD6A06	4	4.5	1.3
EZ303U	55	6000	1.96	3.17	2.25	3.55	SD6A14	4	10	2.8
EZ303U	55	6000	1.96	3.17	2.25	3.55	SD6A14	8	6	1.7
EZ303U	55	6000	1.96	3.17	2.25	3.55	SD6A16	8	10	2.8
<b>EZ4</b>										
EZ401U	96	3000	2.80	2.74	3.00	2.88	SD6A06	4	4.5	1.6
EZ401U	96	3000	2.80	2.74	3.00	2.88	SD6A06	8	3.4	1.2
EZ401U	96	3000	2.80	2.74	3.00	2.88	SD6A14	8	6	2.1
EZ401U	47	6000	2.30	4.56	2.80	5.36	SD6A14	4	10	1.9
EZ401U	47	6000	2.30	4.56	2.80	5.36	SD6A14	8	6	1.1
EZ401U	47	6000	2.30	4.56	2.80	5.36	SD6A16	4	16	3.0
EZ401U	47	6000	2.30	4.56	2.80	5.36	SD6A16	8	10	1.9
EZ401U	47	6000	2.30	4.56	2.80	5.36	SD6A24	8	14	2.6
EZ402U	94	3000	4.70	4.40	5.20	4.80	SD6A14	4	10	2.1
EZ402U	94	3000	4.70	4.40	5.20	4.80	SD6A14	8	6	1.3
EZ402U	94	3000	4.70	4.40	5.20	4.80	SD6A16	8	10	2.1
EZ402U	94	3000	4.70	4.40	5.20	4.80	SD6A24	8	14	2.9
EZ402U	60	6000	3.50	5.65	4.90	7.43	SD6A14	4	10	1.4
EZ402U	60	6000	3.50	5.65	4.90	7.43	SD6A16	4	16	2.2
EZ402U	60	6000	3.50	5.65	4.90	7.43	SD6A16	8	10	1.4
EZ402U	60	6000	3.50	5.65	4.90	7.43	SD6A24	4	22	3.0
EZ402U	60	6000	3.50	5.65	4.90	7.43	SD6A24	8	14	1.9
EZ402U	60	6000	3.50	5.65	4.90	7.43	SD6A26	8	20	2.7
EZ404U	116	3000	6.90	5.80	8.60	6.60	SD6A14	4	10	1.5
EZ404U	116	3000	6.90	5.80	8.60	6.60	SD6A16	4	16	2.4
EZ404U	116	3000	6.90	5.80	8.60	6.60	SD6A16	8	10	1.5
EZ404U	116	3000	6.90	5.80	8.60	6.60	SD6A24	8	14	2.1
EZ404U	78	6000	5.80	7.18	8.40	9.78	SD6A14	4	10	1.0
EZ404U	78	6000	5.80	7.18	8.40	9.78	SD6A16	4	16	1.6
EZ404U	78	6000	5.80	7.18	8.40	9.78	SD6A16	8	10	1.0
EZ404U	78	6000	5.80	7.18	8.40	9.78	SD6A24	4	22	2.3
EZ404U	78	6000	5.80	7.18	8.40	9.78	SD6A24	8	14	1.4
EZ404U	78	6000	5.80	7.18	8.40	9.78	SD6A26	8	20	2.0

Type	$K_{EM}$ [V/1000 min <sup>-1</sup> ]	$n_N$ [rpm]	$M_N$ [Nm]	$I_N$ [A]	$M_0$ [Nm]	$I_0$ [A]	Type	$f_{PWM,PU}$ [kHz]	$I_{2N,PU}$ [A]	$I_{2N,PU}/I_0$
<b>EZ5</b>										
EZ501U	97	3000	4.30	3.74	4.70	4.00	SD6A06	4	4.5	1.1
EZ501U	97	3000	4.30	3.74	4.70	4.00	SD6A14	4	10	2.5
EZ501U	97	3000	4.30	3.74	4.70	4.00	SD6A14	8	6	1.5
EZ501U	97	3000	4.30	3.74	4.70	4.00	SD6A16	8	10	2.5
EZ501U	68	6000	3.40	4.77	4.40	5.80	SD6A14	4	10	1.7
EZ501U	68	6000	3.40	4.77	4.40	5.80	SD6A14	8	6	1.0
EZ501U	68	6000	3.40	4.77	4.40	5.80	SD6A16	4	16	2.8
EZ501U	68	6000	3.40	4.77	4.40	5.80	SD6A16	8	10	1.7
EZ501U	68	6000	3.40	4.77	4.40	5.80	SD6A24	8	14	2.4
EZ502U	121	3000	7.40	5.46	8.00	5.76	SD6A14	4	10	1.7
EZ502U	121	3000	7.40	5.46	8.00	5.76	SD6A14	8	6	1.0
EZ502U	121	3000	7.40	5.46	8.00	5.76	SD6A16	4	16	2.8
EZ502U	121	3000	7.40	5.46	8.00	5.76	SD6A16	8	10	1.7
EZ502U	121	3000	7.40	5.46	8.00	5.76	SD6A24	8	14	2.4
EZ502U	72	6000	5.20	7.35	7.80	9.80	SD6A14	4	10	1.0
EZ502U	72	6000	5.20	7.35	7.80	9.80	SD6A16	4	16	1.6
EZ502U	72	6000	5.20	7.35	7.80	9.80	SD6A16	8	10	1.0
EZ502U	72	6000	5.20	7.35	7.80	9.80	SD6A24	4	22	2.2
EZ502U	72	6000	5.20	7.35	7.80	9.80	SD6A24	8	14	1.4
EZ502U	72	6000	5.20	7.35	7.80	9.80	SD6A26	8	20	2.0
EZ503U	119	3000	9.70	6.90	11.1	7.67	SD6A14	4	10	1.3
EZ503U	119	3000	9.70	6.90	11.1	7.67	SD6A16	4	16	2.1
EZ503U	119	3000	9.70	6.90	11.1	7.67	SD6A16	8	10	1.3
EZ503U	119	3000	9.70	6.90	11.1	7.67	SD6A24	4	22	2.9
EZ503U	119	3000	9.70	6.90	11.1	7.67	SD6A24	8	14	1.8
EZ503U	119	3000	9.70	6.90	11.1	7.67	SD6A26	8	20	2.6
EZ503U	84	6000	6.20	7.64	10.6	11.6	SD6A16	4	16	1.4
EZ503U	84	6000	6.20	7.64	10.6	11.6	SD6A24	4	22	1.9
EZ503U	84	6000	6.20	7.64	10.6	11.6	SD6A24	8	14	1.2
EZ503U	84	6000	6.20	7.64	10.6	11.6	SD6A26	4	32	2.8
EZ503U	84	6000	6.20	7.64	10.6	11.6	SD6A26	8	20	1.7
EZ503U	84	6000	6.20	7.64	10.6	11.6	SD6A34	8	30	2.6
EZ505U	141	3000	13.5	8.80	16.0	10.0	SD6A14	4	10	1.0
EZ505U	141	3000	13.5	8.80	16.0	10.0	SD6A16	4	16	1.6
EZ505U	141	3000	13.5	8.80	16.0	10.0	SD6A16	8	10	1.0
EZ505U	141	3000	13.5	8.80	16.0	10.0	SD6A24	4	22	2.2
EZ505U	141	3000	13.5	8.80	16.0	10.0	SD6A24	8	14	1.4
EZ505U	141	3000	13.5	8.80	16.0	10.0	SD6A26	8	20	2.0
EZ505U	141	3000	13.5	8.80	16.0	10.0	SD6A34	8	30	3.0
EZ505U	103	4500	9.50	8.94	15.3	13.4	SD6A16	4	16	1.2
EZ505U	103	4500	9.50	8.94	15.3	13.4	SD6A24	4	22	1.6
EZ505U	103	4500	9.50	8.94	15.3	13.4	SD6A24	8	14	1.1
EZ505U	103	4500	9.50	8.94	15.3	13.4	SD6A26	4	32	2.4
EZ505U	103	4500	9.50	8.94	15.3	13.4	SD6A26	8	20	1.5
EZ505U	103	4500	9.50	8.94	15.3	13.4	SD6A34	8	30	2.2
<b>EZ7</b>										
EZ701U	95	3000	7.40	7.20	8.30	8.00	SD6A14	4	10	1.3
EZ701U	95	3000	7.40	7.20	8.30	8.00	SD6A16	4	16	2.0
EZ701U	95	3000	7.40	7.20	8.30	8.00	SD6A16	8	10	1.3
EZ701U	95	3000	7.40	7.20	8.30	8.00	SD6A24	4	22	2.8
EZ701U	95	3000	7.40	7.20	8.30	8.00	SD6A24	8	14	1.8
EZ701U	95	3000	7.40	7.20	8.30	8.00	SD6A26	8	20	2.5
EZ701U	76	6000	5.20	6.68	7.90	9.38	SD6A14	4	10	1.1
EZ701U	76	6000	5.20	6.68	7.90	9.38	SD6A16	4	16	1.7
EZ701U	76	6000	5.20	6.68	7.90	9.38	SD6A16	8	10	1.1
EZ701U	76	6000	5.20	6.68	7.90	9.38	SD6A24	4	22	2.4
EZ701U	76	6000	5.20	6.68	7.90	9.38	SD6A24	8	14	1.5
EZ701U	76	6000	5.20	6.68	7.90	9.38	SD6A26	8	20	2.1
EZ702U	133	3000	12.0	8.20	14.4	9.60	SD6A14	4	10	1.0
EZ702U	133	3000	12.0	8.20	14.4	9.60	SD6A16	4	16	1.7
EZ702U	133	3000	12.0	8.20	14.4	9.60	SD6A16	8	10	1.0
EZ702U	133	3000	12.0	8.20	14.4	9.60	SD6A24	4	22	2.3
EZ702U	133	3000	12.0	8.20	14.4	9.60	SD6A24	8	14	1.5
EZ702U	133	3000	12.0	8.20	14.4	9.60	SD6A26	8	20	2.1
EZ702U	82	6000	7.20	8.96	14.3	16.5	SD6A24	4	22	1.3

Type	$K_{EM}$ [V/1000 min <sup>-1</sup> ]	$n_N$ [rpm]	$M_N$ [Nm]	$I_N$ [A]	$M_0$ [Nm]	$I_0$ [A]	Type	$f_{PWM,PU}$ [kHz]	$I_{2N,PU}$ [A]	$I_{2N,PU}/I_0$
<b>EZ7</b>										
EZ702U	82	6000	7.20	8.96	14.3	16.5	SD6A26	4	32	1.9
EZ702U	82	6000	7.20	8.96	14.3	16.5	SD6A26	8	20	1.2
EZ702U	82	6000	7.20	8.96	14.3	16.5	SD6A34	4	44	2.7
EZ702U	82	6000	7.20	8.96	14.3	16.5	SD6A34	8	30	1.8
EZ703U	122	3000	16.5	11.4	20.8	14.0	SD6A16	4	16	1.1
EZ703U	122	3000	16.5	11.4	20.8	14.0	SD6A24	4	22	1.6
EZ703U	122	3000	16.5	11.4	20.8	14.0	SD6A24	8	14	1.0
EZ703U	122	3000	16.5	11.4	20.8	14.0	SD6A26	4	32	2.3
EZ703U	122	3000	16.5	11.4	20.8	14.0	SD6A26	8	20	1.4
EZ703U	122	3000	16.5	11.4	20.8	14.0	SD6A34	8	30	2.1
EZ703U	99	4500	12.1	11.5	20.0	17.8	SD6A24	4	22	1.2
EZ703U	99	4500	12.1	11.5	20.0	17.8	SD6A26	4	32	1.8
EZ703U	99	4500	12.1	11.5	20.0	17.8	SD6A26	8	20	1.1
EZ703U	99	4500	12.1	11.5	20.0	17.8	SD6A34	4	44	2.5
EZ703U	99	4500	12.1	11.5	20.0	17.8	SD6A34	8	30	1.7
EZ703U	99	4500	12.1	11.5	20.0	17.8	SD6A36	8	50	2.8
EZ705U	140	3000	21.3	14.2	30.2	19.5	SD6A24	4	22	1.1
EZ705U	140	3000	21.3	14.2	30.2	19.5	SD6A26	4	32	1.6
EZ705U	140	3000	21.3	14.2	30.2	19.5	SD6A26	8	20	1.0
EZ705U	140	3000	21.3	14.2	30.2	19.5	SD6A34	4	44	2.3
EZ705U	140	3000	21.3	14.2	30.2	19.5	SD6A34	8	30	1.5
EZ705U	140	3000	21.3	14.2	30.2	19.5	SD6A36	8	50	2.6
EZ705U	106	4500	16.4	14.8	30.0	25.2	SD6A26	4	32	1.3
EZ705U	106	4500	16.4	14.8	30.0	25.2	SD6A34	4	44	1.8
EZ705U	106	4500	16.4	14.8	30.0	25.2	SD6A34	8	30	1.2
EZ705U	106	4500	16.4	14.8	30.0	25.2	SD6A36	4	70	2.8
EZ705U	106	4500	16.4	14.8	30.0	25.2	SD6A36	8	50	2.0
EZ705U	106	4500	16.4	14.8	30.0	25.2	SD6A38	8	60	2.4
<b>EZ8</b>										
EZ813U	239	2000	39.0	14.9	43.7	16.5	SD6A24	4	22	1.3
EZ813U	239	2000	39.0	14.9	43.7	16.5	SD6A26	4	32	1.9
EZ813U	239	2000	39.0	14.9	43.7	16.5	SD6A26	8	20	1.2
EZ813U	239	2000	39.0	14.9	43.7	16.5	SD6A34	4	44	2.7
EZ813U	239	2000	39.0	14.9	43.7	16.5	SD6A34	8	30	1.8
EZ813U	117	4000	25.2	19.8	43.7	32.8	SD6A34	4	44	1.3
EZ813U	117	4000	25.2	19.8	43.7	32.8	SD6A36	4	70	2.1
EZ813U	117	4000	25.2	19.8	43.7	32.8	SD6A36	8	50	1.5
EZ813U	117	4000	25.2	19.8	43.7	32.8	SD6A38	4	85	2.6
EZ813U	117	4000	25.2	19.8	43.7	32.8	SD6A38	8	60	1.8
EZ815U	239	2000	57.8	21.5	68.8	25.2	SD6A26	4	32	1.3
EZ815U	239	2000	57.8	21.5	68.8	25.2	SD6A34	4	44	1.7
EZ815U	239	2000	57.8	21.5	68.8	25.2	SD6A34	8	30	1.2
EZ815U	239	2000	57.8	21.5	68.8	25.2	SD6A36	4	70	2.8
EZ815U	239	2000	57.8	21.5	68.8	25.2	SD6A36	8	50	2.0
EZ815U	239	2000	57.8	21.5	68.8	25.2	SD6A38	8	60	2.4
EZ815U	117	4000	26.1	20.9	67.1	50.3	SD6A36	4	70	1.4
EZ815U	117	4000	26.1	20.9	67.1	50.3	SD6A38	4	85	1.7
EZ815U	117	4000	26.1	20.9	67.1	50.3	SD6A38	8	60	1.2

## IC 416 forced ventilation

Type	$K_{EM}$ [V/1000 min <sup>-1</sup> ]	$n_N$ [rpm]	$M_N$ [Nm]	$I_N$ [A]	$M_0$ [Nm]	$I_0$ [A]	Type	$f_{PWM,PU}$ [kHz]	$I_{2N,PU}$ [A]	$I_{2N,PU}/I_0$
<b>EZ4</b>										
EZ401B	96	3000	3.40	3.40	3.70	3.60	SD6A06	4	4.5	1.3
EZ401B	96	3000	3.40	3.40	3.70	3.60	SD6A14	4	10	2.8
EZ401B	96	3000	3.40	3.40	3.70	3.60	SD6A14	8	6	1.7
EZ401B	96	3000	3.40	3.40	3.70	3.60	SD6A16	8	10	2.8
EZ401B	47	6000	2.90	5.62	3.50	6.83	SD6A14	4	10	1.5
EZ401B	47	6000	2.90	5.62	3.50	6.83	SD6A16	4	16	2.3
EZ401B	47	6000	2.90	5.62	3.50	6.83	SD6A16	8	10	1.5
EZ401B	47	6000	2.90	5.62	3.50	6.83	SD6A24	8	14	2.1
EZ401B	47	6000	2.90	5.62	3.50	6.83	SD6A26	8	20	2.9
EZ402B	94	3000	5.90	5.50	6.30	5.80	SD6A14	4	10	1.7
EZ402B	94	3000	5.90	5.50	6.30	5.80	SD6A14	8	6	1.0
EZ402B	94	3000	5.90	5.50	6.30	5.80	SD6A16	4	16	2.8
EZ402B	94	3000	5.90	5.50	6.30	5.80	SD6A16	8	10	1.7
EZ402B	94	3000	5.90	5.50	6.30	5.80	SD6A24	8	14	2.4
EZ402B	60	6000	5.10	7.88	6.40	9.34	SD6A14	4	10	1.1
EZ402B	60	6000	5.10	7.88	6.40	9.34	SD6A16	4	16	1.7
EZ402B	60	6000	5.10	7.88	6.40	9.34	SD6A16	8	10	1.1
EZ402B	60	6000	5.10	7.88	6.40	9.34	SD6A24	4	22	2.4
EZ402B	60	6000	5.10	7.88	6.40	9.34	SD6A24	8	14	1.5
EZ402B	60	6000	5.10	7.88	6.40	9.34	SD6A26	8	20	2.1
EZ404B	116	3000	10.2	8.20	11.2	8.70	SD6A14	4	10	1.2
EZ404B	116	3000	10.2	8.20	11.2	8.70	SD6A16	4	16	1.8
EZ404B	116	3000	10.2	8.20	11.2	8.70	SD6A16	8	10	1.2
EZ404B	116	3000	10.2	8.20	11.2	8.70	SD6A24	4	22	2.5
EZ404B	116	3000	10.2	8.20	11.2	8.70	SD6A24	8	14	1.6
EZ404B	116	3000	10.2	8.20	11.2	8.70	SD6A26	8	20	2.3
EZ404B	78	6000	8.00	9.98	10.5	12.0	SD6A16	4	16	1.3
EZ404B	78	6000	8.00	9.98	10.5	12.0	SD6A24	4	22	1.8
EZ404B	78	6000	8.00	9.98	10.5	12.0	SD6A24	8	14	1.2
EZ404B	78	6000	8.00	9.98	10.5	12.0	SD6A26	4	32	2.7
EZ404B	78	6000	8.00	9.98	10.5	12.0	SD6A26	8	20	1.7
EZ404B	78	6000	8.00	9.98	10.5	12.0	SD6A34	8	30	2.5
<b>EZ5</b>										
EZ501B	97	3000	5.40	4.70	5.80	5.00	SD6A14	4	10	2.0
EZ501B	97	3000	5.40	4.70	5.80	5.00	SD6A14	8	6	1.2
EZ501B	97	3000	5.40	4.70	5.80	5.00	SD6A16	8	10	2.0
EZ501B	97	3000	5.40	4.70	5.80	5.00	SD6A24	8	14	2.8
EZ501B	68	6000	4.50	6.70	5.70	7.50	SD6A14	4	10	1.3
EZ501B	68	6000	4.50	6.70	5.70	7.50	SD6A16	4	16	2.1
EZ501B	68	6000	4.50	6.70	5.70	7.50	SD6A16	8	10	1.3
EZ501B	68	6000	4.50	6.70	5.70	7.50	SD6A24	4	22	2.9
EZ501B	68	6000	4.50	6.70	5.70	7.50	SD6A24	8	14	1.9
EZ501B	68	6000	4.50	6.70	5.70	7.50	SD6A26	8	20	2.7
EZ502B	121	3000	10.3	7.80	11.2	8.16	SD6A14	4	10	1.2
EZ502B	121	3000	10.3	7.80	11.2	8.16	SD6A16	4	16	2.0
EZ502B	121	3000	10.3	7.80	11.2	8.16	SD6A16	8	10	1.2
EZ502B	121	3000	10.3	7.80	11.2	8.16	SD6A24	4	22	2.7
EZ502B	121	3000	10.3	7.80	11.2	8.16	SD6A24	8	14	1.7
EZ502B	121	3000	10.3	7.80	11.2	8.16	SD6A26	8	20	2.5
EZ502B	72	6000	8.20	11.4	10.5	13.4	SD6A16	4	16	1.2
EZ502B	72	6000	8.20	11.4	10.5	13.4	SD6A24	4	22	1.6
EZ502B	72	6000	8.20	11.4	10.5	13.4	SD6A24	8	14	1.0
EZ502B	72	6000	8.20	11.4	10.5	13.4	SD6A26	4	32	2.4
EZ502B	72	6000	8.20	11.4	10.5	13.4	SD6A26	8	20	1.5
EZ502B	72	6000	8.20	11.4	10.5	13.4	SD6A34	8	30	2.2
EZ503B	119	3000	14.4	10.9	15.9	11.8	SD6A16	4	16	1.4
EZ503B	119	3000	14.4	10.9	15.9	11.8	SD6A24	4	22	1.9
EZ503B	119	3000	14.4	10.9	15.9	11.8	SD6A24	8	14	1.2
EZ503B	119	3000	14.4	10.9	15.9	11.8	SD6A26	4	32	2.7
EZ503B	119	3000	14.4	10.9	15.9	11.8	SD6A26	8	20	1.7
EZ503B	119	3000	14.4	10.9	15.9	11.8	SD6A34	8	30	2.5
EZ503B	84	6000	10.4	13.5	14.8	15.9	SD6A16	4	16	1.0
EZ503B	84	6000	10.4	13.5	14.8	15.9	SD6A24	4	22	1.4
EZ503B	84	6000	10.4	13.5	14.8	15.9	SD6A26	4	32	2.0

Type	$K_{EM}$ [V/1000 min <sup>-1</sup> ]	$n_N$ [rpm]	$M_N$ [Nm]	$I_N$ [A]	$M_0$ [Nm]	$I_0$ [A]	Type	$f_{PWM,PU}$ [kHz]	$I_{2N,PU}$ [A]	$I_{2N,PU}/I_0$
<b>EZ5</b>										
EZ503B	84	6000	10.4	13.5	14.8	15.9	SD6A26	8	20	1.3
EZ503B	84	6000	10.4	13.5	14.8	15.9	SD6A34	4	44	2.8
EZ503B	84	6000	10.4	13.5	14.8	15.9	SD6A34	8	30	1.9
EZ505B	141	3000	20.2	13.7	23.4	14.7	SD6A16	4	16	1.1
EZ505B	141	3000	20.2	13.7	23.4	14.7	SD6A24	4	22	1.5
EZ505B	141	3000	20.2	13.7	23.4	14.7	SD6A26	4	32	2.2
EZ505B	141	3000	20.2	13.7	23.4	14.7	SD6A26	8	20	1.4
EZ505B	141	3000	20.2	13.7	23.4	14.7	SD6A34	4	44	3.0
EZ505B	141	3000	20.2	13.7	23.4	14.7	SD6A34	8	30	2.0
EZ505B	103	4500	16.4	16.4	22.0	19.4	SD6A24	4	22	1.1
EZ505B	103	4500	16.4	16.4	22.0	19.4	SD6A26	4	32	1.7
EZ505B	103	4500	16.4	16.4	22.0	19.4	SD6A26	8	20	1.0
EZ505B	103	4500	16.4	16.4	22.0	19.4	SD6A34	4	44	2.3
EZ505B	103	4500	16.4	16.4	22.0	19.4	SD6A34	8	30	1.6
EZ505B	103	4500	16.4	16.4	22.0	19.4	SD6A36	8	50	2.6
<b>EZ7</b>										
EZ701B	95	3000	9.70	9.50	10.5	10.0	SD6A14	4	10	1.0
EZ701B	95	3000	9.70	9.50	10.5	10.0	SD6A16	4	16	1.6
EZ701B	95	3000	9.70	9.50	10.5	10.0	SD6A16	8	10	1.0
EZ701B	95	3000	9.70	9.50	10.5	10.0	SD6A24	4	22	2.2
EZ701B	95	3000	9.70	9.50	10.5	10.0	SD6A24	8	14	1.4
EZ701B	95	3000	9.70	9.50	10.5	10.0	SD6A26	8	20	2.0
EZ701B	95	3000	9.70	9.50	10.5	10.0	SD6A34	8	30	3.0
EZ701B	76	6000	7.50	10.6	10.2	12.4	SD6A16	4	16	1.3
EZ701B	76	6000	7.50	10.6	10.2	12.4	SD6A24	4	22	1.8
EZ701B	76	6000	7.50	10.6	10.2	12.4	SD6A24	8	14	1.1
EZ701B	76	6000	7.50	10.6	10.2	12.4	SD6A26	4	32	2.6
EZ701B	76	6000	7.50	10.6	10.2	12.4	SD6A26	8	20	1.6
EZ701B	76	6000	7.50	10.6	10.2	12.4	SD6A34	8	30	2.4
EZ702B	133	3000	16.6	11.8	19.3	12.9	SD6A16	4	16	1.2
EZ702B	133	3000	16.6	11.8	19.3	12.9	SD6A24	4	22	1.7
EZ702B	133	3000	16.6	11.8	19.3	12.9	SD6A24	8	14	1.1
EZ702B	133	3000	16.6	11.8	19.3	12.9	SD6A26	4	32	2.5
EZ702B	133	3000	16.6	11.8	19.3	12.9	SD6A26	8	20	1.6
EZ702B	133	3000	16.6	11.8	19.3	12.9	SD6A34	8	30	2.3
EZ702B	82	6000	12.5	16.7	19.3	22.1	SD6A24	4	22	1.0
EZ702B	82	6000	12.5	16.7	19.3	22.1	SD6A26	4	32	1.5
EZ702B	82	6000	12.5	16.7	19.3	22.1	SD6A34	4	44	2.0
EZ702B	82	6000	12.5	16.7	19.3	22.1	SD6A34	8	30	1.4
EZ702B	82	6000	12.5	16.7	19.3	22.1	SD6A36	8	50	2.3
EZ702B	82	6000	12.5	16.7	19.3	22.1	SD6A38	8	60	2.7
EZ703B	122	3000	24.0	18.2	28.0	20.0	SD6A24	4	22	1.1
EZ703B	122	3000	24.0	18.2	28.0	20.0	SD6A26	4	32	1.6
EZ703B	122	3000	24.0	18.2	28.0	20.0	SD6A26	8	20	1.0
EZ703B	122	3000	24.0	18.2	28.0	20.0	SD6A34	4	44	2.2
EZ703B	122	3000	24.0	18.2	28.0	20.0	SD6A34	8	30	1.5
EZ703B	122	3000	24.0	18.2	28.0	20.0	SD6A36	8	50	2.5
EZ703B	122	3000	24.0	18.2	28.0	20.0	SD6A38	8	60	3.0
EZ703B	99	4500	19.8	20.3	27.2	24.2	SD6A26	4	32	1.3
EZ703B	99	4500	19.8	20.3	27.2	24.2	SD6A34	4	44	1.8
EZ703B	99	4500	19.8	20.3	27.2	24.2	SD6A34	8	30	1.2
EZ703B	99	4500	19.8	20.3	27.2	24.2	SD6A36	4	70	2.9
EZ703B	99	4500	19.8	20.3	27.2	24.2	SD6A36	8	50	2.1
EZ703B	99	4500	19.8	20.3	27.2	24.2	SD6A38	8	60	2.5
EZ705B	140	3000	33.8	22.9	41.8	26.5	SD6A26	4	32	1.2
EZ705B	140	3000	33.8	22.9	41.8	26.5	SD6A34	4	44	1.7
EZ705B	140	3000	33.8	22.9	41.8	26.5	SD6A34	8	30	1.1
EZ705B	140	3000	33.8	22.9	41.8	26.5	SD6A36	4	70	2.6
EZ705B	140	3000	33.8	22.9	41.8	26.5	SD6A36	8	50	1.9
EZ705B	140	3000	33.8	22.9	41.8	26.5	SD6A38	8	60	2.3
EZ705B	106	4500	27.7	25.4	39.4	32.8	SD6A34	4	44	1.3
EZ705B	106	4500	27.7	25.4	39.4	32.8	SD6A36	4	70	2.1
EZ705B	106	4500	27.7	25.4	39.4	32.8	SD6A36	8	50	1.5
EZ705B	106	4500	27.7	25.4	39.4	32.8	SD6A38	4	85	2.6
EZ705B	106	4500	27.7	25.4	39.4	32.8	SD6A38	8	60	1.8

Type	$K_{EM}$ [V/1000 min <sup>-1</sup> ]	$n_N$ [rpm]	$M_N$ [Nm]	$I_N$ [A]	$M_0$ [Nm]	$I_0$ [A]	Type	$f_{PWM,PU}$ [kHz]	$I_{2N,PU}$ [A]	$I_{2N,PU}/I_0$
<b>EZ8</b>										
EZ813B	239	2000	57.3	21.9	61.6	22.9	SD6A26	4	32	1.4
EZ813B	239	2000	57.3	21.9	61.6	22.9	SD6A34	4	44	1.9
EZ813B	239	2000	57.3	21.9	61.6	22.9	SD6A34	8	30	1.3
EZ813B	239	2000	57.3	21.9	61.6	22.9	SD6A36	8	50	2.2
EZ813B	239	2000	57.3	21.9	61.6	22.9	SD6A38	8	60	2.6
EZ813B	117	4000	49.5	38.1	62.9	46.6	SD6A36	4	70	1.5
EZ813B	117	4000	49.5	38.1	62.9	46.6	SD6A36	8	50	1.1
EZ813B	117	4000	49.5	38.1	62.9	46.6	SD6A38	4	85	1.8
EZ813B	117	4000	49.5	38.1	62.9	46.6	SD6A38	8	60	1.3
EZ815B	239	2000	91.0	33.7	100	36.3	SD6A34	4	44	1.2
EZ815B	239	2000	91.0	33.7	100	36.3	SD6A36	4	70	1.9
EZ815B	239	2000	91.0	33.7	100	36.3	SD6A36	8	50	1.4
EZ815B	239	2000	91.0	33.7	100	36.3	SD6A38	4	85	2.3
EZ815B	239	2000	91.0	33.7	100	36.3	SD6A38	8	60	1.7
EZ815B	117	4000	73.6	56.2	90.8	65.0	SD6A36	4	70	1.1
EZ815B	117	4000	73.6	56.2	90.8	65.0	SD6A38	4	85	1.3

## 5.4 Accessories

You can find information about the available accessories in the following chapters.

### 5.4.1 Safety technology

#### Information

The drive controller is delivered with the ST6 safety module in the standard design. If you want a drive controller with extended safety technology, you must order this option together with the drive controller. The safety modules are an integrated part of the drive controllers and must not be modified.

#### ST6 safety module – STO using terminals

Included in the standard version.



ID No. 56431

Accessory for the use of the Safe Torque Off safety function (STO) in safety-relevant applications (PL e, SIL 3) in accordance with EN ISO 13849-1 and EN 61800-5-2. Connection to a higher-level safety circuit via terminal X12.

#### SE6 safety module – Extended safety technology using terminals



ID No. 56432

Optional accessory for use in safety-related applications up to PL e, SIL 3 in accordance with EN ISO 13849-1 and EN 61800-5-2. In addition to the basic Safe Torque Off (STO) safety function, SE6 provides other safety functions specified in EN 61800-5-2. In addition to the Safe Stop 1 (SS1) and Safe Stop 2 (SS2) safe stop functions, they include Safely-Limited Speed (SLS), Safe Brake Control (SBC), Safe Direction (SDI) and Safely-Limited Increment (SLI). The normative safety functions are supplemented by practical additional functions such as Safe Brake Test (SBT). Connection to the higher-level safety circuit using terminals X14 and X15.

#### X50 adapter cable (SE6 option)



ID No. 56434

Adapter cable for the X50 encoder interface of the SE6 safety module with flying leads, length: 1.5 m.

## 5.4.2 Communication

The SD6 drive controller has two interfaces for IGB communication on the top of the device as standard. The communication module is installed in the shaft at the top and it is used to connect the drive controller to the fieldbus system.

The following communication modules are available:

- EC6 for the EtherCAT connection
- CA6 for the CANopen connection
- PN6 for the PROFINET connection

### IGB connecting cable



Cable for connecting the X3A or X3B interface for IGB, CAT5e, magenta.

The following designs are available:

ID No. 56489: 0.4 m.

ID No. 56490: 2 m.

### PC connecting cable



ID No. 49857

Cable for connecting the X3A or X3B interface with the PC, CAT5e, blue, length: 5 m.

### USB 2.0 Ethernet adapter



ID No. 49940

Adapter for connecting Ethernet to a USB port.

### EC6 communication module

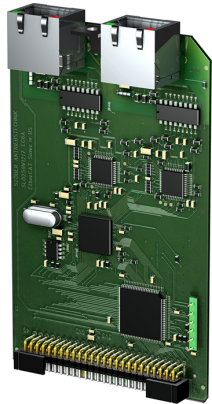

ID No. 138425

Communication module for the EtherCAT connection.

### EtherCAT cables



Ethernet patch cable, CAT5e, yellow.

The following designs are available:

ID no. 49313: length approx. 0.25 m.

ID no. 49314: length approx. 0.5 m.

**CA6 communication module**

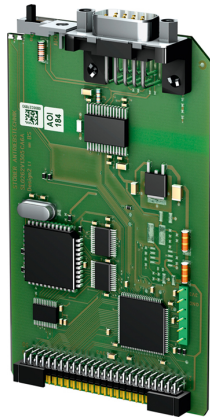

ID No. 138427  
 Communication module for the CANopen connection.

**PN6 communication module**

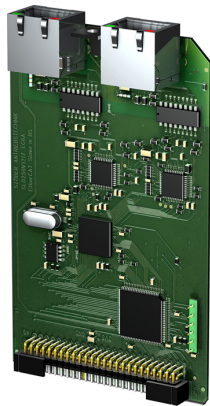

ID No. 138426  
 Communication module for the PROFINET connection.

**5.4.3 Terminal module**

**XI6 terminal module**

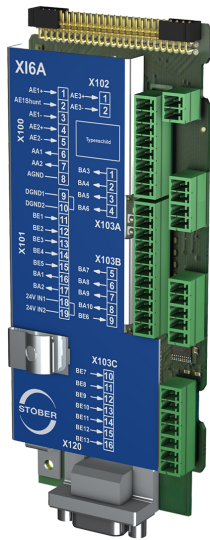

ID no. 138421  
 Terminal module for connecting analog and digital signals as well as encoders.

Inputs and outputs:

- 13 digital inputs (24 V<sub>DC</sub>)
- 10 digital outputs (24 V<sub>DC</sub>)
- 3 analog inputs (±10 V<sub>DC</sub>, 1 x 0 – 20 mA, 16 bits)
- 2 analog outputs (±10 V<sub>DC</sub>, 12 bits)

Supported encoders and interfaces:

- SSI encoder (evaluation and simulation)
- Differential TTL incremental encoder (evaluation and simulation)
- HTL incremental encoder, single-ended (evaluation and simulation)
- Differential TTL pulse/direction interface (evaluation and simulation)
- HTL pulse/direction interface, single-ended (evaluation and simulation)

### RI6 terminal module



ID no. 138422

Terminal module for connecting analog and digital signals as well as encoders.

Inputs and outputs:

- 5 digital inputs ( $24 V_{DC}$ )
- 2 digital outputs ( $24 V_{DC}$ )
- 2 analog inputs ( $\pm 10 V_{DC}$ ,  $1 \times 0 - 20 \text{ mA}$ , 16 bits)
- 2 analog outputs ( $\pm 10 V_{DC}$ ,  $\pm 20 \text{ mA}$ , 12 bits)

Supported encoders and interfaces:

- Resolver (evaluation)
- EnDat 2.1 sin/cos encoder (evaluation)
- EnDat 2.1/2.2 digital encoder (evaluation)
- Sin/cos encoder (evaluation)
- SSI encoder (simulation and evaluation)
- Differential TTL incremental encoder (evaluation and simulation)
- TTL incremental encoder, single-ended (evaluation)
- HTL incremental encoder, single-ended (evaluation and simulation)
- Differential TTL pulse/direction interface (evaluation and simulation)
- TTL pulse/direction interface, single-ended (evaluation)
- HTL pulse/direction interface, single-ended (evaluation and simulation)

### Information

For connecting EnDat 2.1 sin/cos cables with a 15-pin D-sub connector to an integrated motor temperature sensor, you must use the AP6A02 interface adapter (ID No. 56523), available separately, to lead out the temperature sensor cores.

### IO6 terminal module



ID no. 138420

Terminal module for connecting analog and digital signals as well as encoders.

Inputs and outputs:

- 5 digital inputs ( $24 V_{DC}$ )
- 2 digital outputs ( $24 V_{DC}$ )
- 2 analog inputs ( $\pm 10 V_{DC}$ ,  $1 \times 0 - 20 \text{ mA}$ , 12 bits)
- 2 analog outputs ( $\pm 10 V_{DC}$ ,  $\pm 20 \text{ mA}$ , 12 bits)

Supported encoders and interfaces:

- HTL incremental encoder, single-ended (evaluation and simulation)
- HTL pulse/direction interface, single-ended (evaluation and simulation)

## 5.4.4 DC link connection

If you want to connect SD6 drive controllers in the DC link group, you will need Quick DC-Link modules of type DL6A.

You receive the DL6A rear section modules in different designs for a horizontal connection, suitable for the size of the drive controller.

The quick fastening clamps for attaching the copper rails and an insulation connection piece are contained in the scope of delivery. The copper rails are not included in the scope of delivery. These must have a cross-section of 5 x 12 mm. Insulation end sections are available separately.

### Quick DC-Link DL6A – rear section module for drive controller

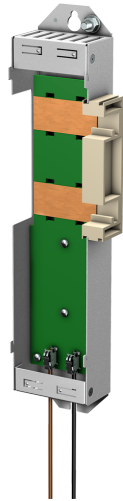

The following designs are available:

DL6A0

ID No. 56440

Rear section module for size 0 drive controller.

DL6A1

ID No. 56441

Rear section module for size 1 drive controller.

DL6A2

ID No. 56442

Rear section module for size 2 drive controller.

DL6A3

ID No. 56443

Rear section module for size 3 drive controller.

### Quick DC-Link DL6A – insulation end section

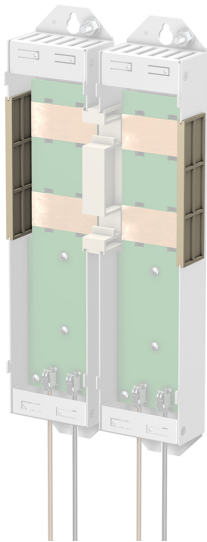

ID No. 56494

Insulation end sections for the left and right termination of the group, 2 pcs.

## 5.4.5 Braking resistor

In addition to drive controllers, STÖBER offers the following braking resistors described below in various sizes and performance classes. For the selection, note the minimum permitted braking resistors specified in the technical data of the individual drive controller types.

### 5.4.5.1 Tubular fixed resistor FZMU, FZZMU

Type	FZMU 400×65			FZZMU 400×65		
	49010	55445	55446	53895	55447	55448
SD6A02	X	—	—	—	—	—
SD6A04	X	—	—	—	—	—
SD6A06	X	—	—	—	—	—
SD6A14	(X)	—	—	X	—	—
SD6A16	(X)	—	—	X	—	—
SD6A24	(—)	X	—	(X)	X	—
SD6A26	(—)	X	—	(X)	X	—
SD6A34	(—)	(X)	X	(—)	(X)	X
SD6A36	(—)	(X)	X	(—)	(X)	X
SD6A38	(—)	(X)	X	(—)	(X)	X

Tab. 35: Assignment of FZMU, FZZMU braking resistor – SD6 drive controller

X	Recommended
(X)	Possible
(—)	Useful under certain conditions
—	Not possible

#### Properties

Technical data	FZMU 400×65			FZZMU 400×65		
	49010	55445	55446	53895	55447	55448
ID No.	49010	55445	55446	53895	55447	55448
Type	Tubular fixed resistor			Tubular fixed resistor		
Resistance [ $\Omega$ ]	100 $\pm$ 10%	22 $\pm$ 10%	15 $\pm$ 10%	47 $\pm$ 10%	22 $\pm$ 10%	15 $\pm$ 10%
Thermal drift	$\pm$ 10%			$\pm$ 10%		
Power [W]	600			1200		
Therm. time const. $\tau_{th}$ [s]	40			40		
Pulse power for < 1 s [kW]	18			36		
$U_{max}$ [V]	848			848		
Weight without packaging [g]	2200			4170		
Protection class	IP20			IP20		
Marks and test symbols	cURus, CE, UKCA			cURus, CE, UKCA		

Tab. 36: FZMU, FZZMU technical data

Dimensions

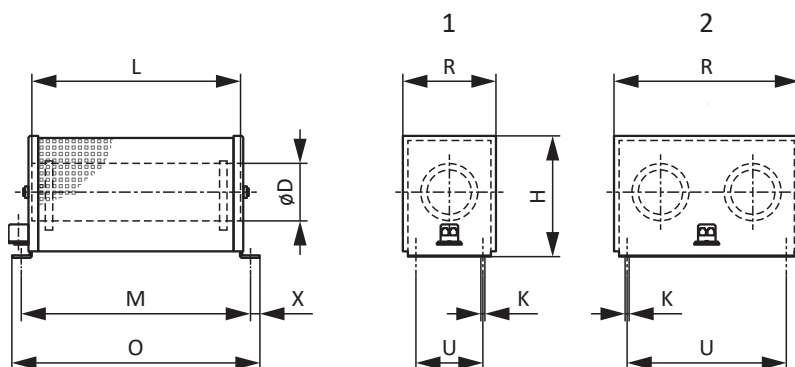

Fig. 4: FZMU (1), FZZMU (2) dimensional drawing

Dimension	FZMU 400×65			FZZMU 400×65		
	ID No.	55445	55446	53895	55447	55448
L x D		400 × 65		400 × 65		
H		120		120		
K		6.5 × 12		6.5 × 12		
M		430		426		
O		485		485		
R		92		185		
U		64		150		
X		10		10		

Tab. 37: FZMU, FZZMU dimensions [mm]

5.4.5.2 GVADU, GBADU flat resistor

Type	GVADU 210×20	GBADU 265×30	GBADU 405×30	GBADU 335×30	GBADU 265×30
ID No.	55441	55442	55499	55443	55444
SD6A02	X	X	X	—	—
SD6A04	X	X	X	—	—
SD6A06	X	X	X	—	—
SD6A14	(X)	(X)	(X)	X	—
SD6A16	(X)	(X)	(X)	X	—
SD6A24	(—)	(—)	(—)	(X)	X
SD6A26	(—)	(—)	(—)	(X)	X
SD6A34	(—)	(—)	(—)	(—)	(X)
SD6A36	(—)	(—)	(—)	(—)	(X)
SD6A38	(—)	(—)	(—)	(—)	(X)

Tab. 38: Assignment of GVADU, GBADU braking resistor – SD6 drive controller

- X Recommended
- (X) Possible
- (—) Useful under certain conditions
- Not possible

Properties

Technical data	GVADU 210×20	GBADU 265×30	GBADU 405×30	GBADU 335×30	GBADU 265×30
ID No.	55441	55442	55499	55443	55444
Type	Flat resistor				
Resistance [Ω]	100 ±10%	100 ±10%	100 ±10%	47 ±10%	22 ±10%
Thermal drift	±10%	±10%	±10%	±10%	±10%
Power [W]	150	300	500	400	300
Therm. time const. $\tau_{th}$ [s]	60	60	60	60	60
Pulse power for < 1 s [kW]	3.3	6.6	11	8.8	6.6

Technical data	GVADU 210×20	GBADU 265×30	GBADU 405×30	GBADU 335×30	GBADU 265×30
$U_{max}$ [V]	848	848	848	848	848
Cable design	Radox	FEP	FEP	FEP	FEP
Cable length [mm]	500	1500	500	1500	1500
Conductor cross-section [AWG]	18/19 (0.82 mm <sup>2</sup> )	14/19 (1.9 mm <sup>2</sup> )	14/19 (1.9 mm <sup>2</sup> )	14/19 (1.9 mm <sup>2</sup> )	14/19 (1.9 mm <sup>2</sup> )
Weight without packaging [g]	300	930	1410	1200	930
Protection class	IP54	IP54	IP54	IP54	IP54
Test symbols	cURus, CE, UKCA				

Tab. 39: GVADU, GBADU technical data

### Dimensions

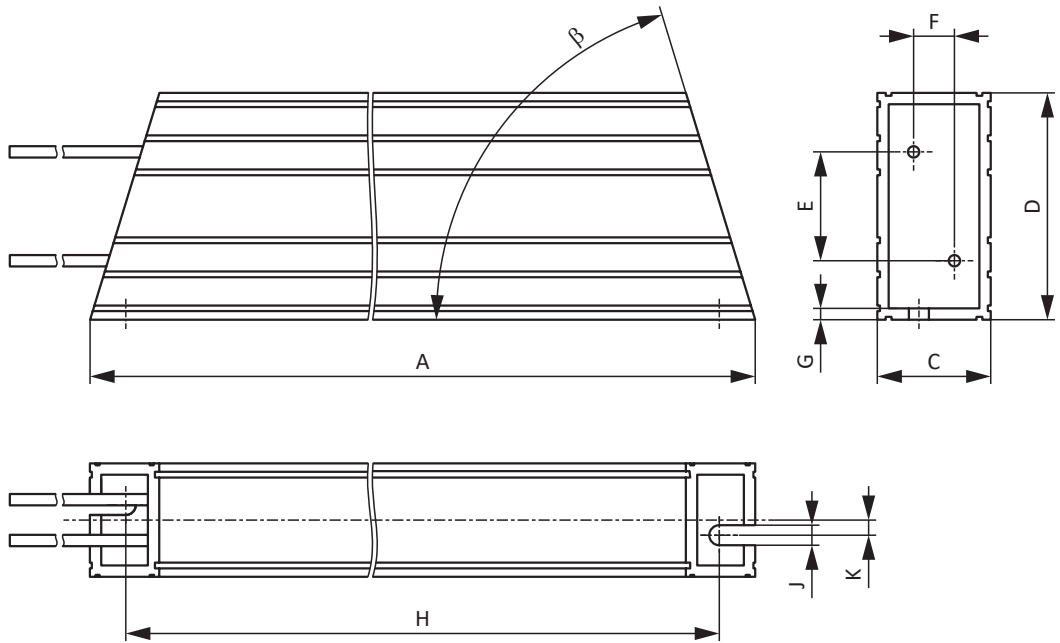

Fig. 5: GVADU, GBADU dimensional drawing

Dimension	GVADU 210×20	GBADU 265×30	GBADU 405×30	GBADU 335×30	GBADU 265×30
ID No.	55441	55442	55499	55443	55444
A	210	265	405	335	265
H	192	246	386	316	246
C	20	30	30	30	30
D	40	60	60	60	60
E	18.2	28.8	28.8	28.8	28.8
F	6.2	10.8	10.8	10.8	10.8
G	2	3	3	3	3
K	2.5	4	4	4	4
J	4.3	5.3	5.3	5.3	5.3
$\beta$	65°	73°	73°	73°	73°

Tab. 40: GVADU, GBADU dimensions [mm]

### 5.4.5.3 FGFKU steel-grid fixed resistor

Type	FGFKU 3100502	FGFKU 3100502	FGFKU 3111202
ID No.	55449	55450	55451
SD6A24	X	—	—
SD6A26	X	—	—
SD6A34	(X)	X	X
SD6A36	(X)	X	X
SD6A38	(X)	X	X

Tab. 41: Assignment of FGFKU braking resistor – SD6 drive controller

- X Recommended
- (X) Possible
- Not possible

#### Properties

Technical data	FGFKU 3100502	FGFKU 3100502	FGFKU 3111202
ID No.	55449	55450	55451
Type	Steel-grid fixed resistor		
Resistance [ $\Omega$ ]	22 $\pm$ 10%	15 $\pm$ 10%	15 $\pm$ 10%
Thermal drift	$\pm$ 10%	$\pm$ 10%	$\pm$ 10%
Power [W]	2500	2500	6000
Therm. time const. $\tau_{th}$ [s]	30	30	20
Pulse power for < 1 s [kW]	50	50	120
$U_{max}$ [V]	848	848	848
Weight without packaging [g]	7500	7500	12000
Protection class	IP20	IP20	IP20
Marks and test symbols	cURus, CE, UKCA		

Tab. 42: FGFKU technical data

#### Dimensions

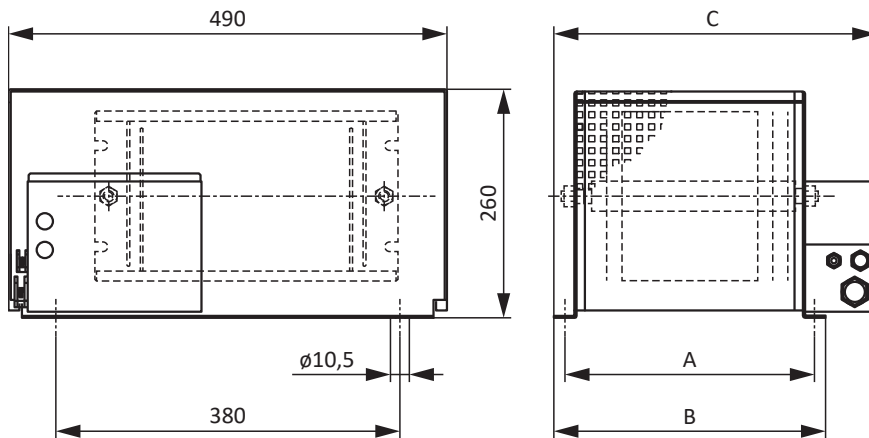

Fig. 6: FGFKU dimensional drawing

Dimension	FGFKU 3100502	FGFKU 3100502	FGFKU 3111202
ID No.	55449	55450	55451
A	270	270	370
B	295	295	395
C	355	355	455

Tab. 43: FGFKU dimensions [mm]

### 5.4.5.4 Rear section braking resistor RB 5000

Type	RB 5022	RB 5047	RB 5100
ID No.	45618	44966	44965
SD6A02	—	—	X
SD6A04	—	—	X
SD6A06	—	—	X
SD6A14	—	X	(X)
SD6A16	—	X	(X)
SD6A24	X	—	—
SD6A26	X	—	—
SD6A34	—	—	—
SD6A36	—	—	—
SD6A38	—	—	—

Tab. 44: Assignment of RB 5000 braking resistor – SD6 drive controller

X	Recommended
(X)	Possible
—	Not possible

#### Properties

Technical data	RB 5022	RB 5047	RB 5100
ID No.	45618	44966	44965
Resistance [ $\Omega$ ]	$22 \pm 10 \%$	$47 \pm 10 \%$	$100 \pm 10 \%$
Thermal drift	$\pm 10 \%$	$\pm 10 \%$	$\pm 10 \%$
Power [W]	100	60	60
Therm. time const. $\tau_{th}$ [s]	8	8	8
Pulse power for < 1 s [kW]	1.5	1.0	1.0
$U_{max}$ [V]	800	800	800
Weight without packaging [g]	640	460	440
Cable design	Radox	Radox	Radox
Cable length [mm]	250	250	250
Conductor cross-section [AWG]	18/19	18/19	18/19
	(0.82 mm <sup>2</sup> )	(0.82 mm <sup>2</sup> )	(0.82 mm <sup>2</sup> )
Maximum torque of M5 threaded bolts [Nm]	5	5	5
Protection class	IP40	IP40	IP40
Marks and test symbols	cURus, CE, UKCA	cURus, CE, UKCA	cURus, CE, UKCA

Tab. 45: RB 5000 technical data

#### Dimensions

Dimension	RB 5022	RB 5047	RB 5100
ID No.	45618	44966	44965
Height	300	300	300
Width	94	62	62
Depth	18	18	18
Drilling diagram corresponds to size	Size 2	Size 1	Size 0 and Size 1

Tab. 46: RB 5000 dimensions [mm]

## 5.4.6 Choke

Technical specifications for suitable chokes can be found in the following chapters.

### 5.4.6.1 TEP power choke

For each size 3 SD6 drive controller, you need one power choke. It dampens voltage and current peaks and reduces the load of the drive controller power feed-in.

#### Properties

Technical data	TEP4010-2US00
ID No.	56528
Phases	3
Thermally allowed continuous current	100 A
Nominal current $I_{N,MF}$	90 A
Absolute loss $P_V$	103 W
Inductance	0.14 mH
Voltage range	3 × 400 V <sub>AC</sub> +32%/-50% 3 × 480 V <sub>AC</sub> +10%/-58%
Voltage drop $U_k$	2%
Frequency range	50/60 Hz
Protection class	IP00
Max. surrounding temperature $\vartheta_{amb,max}$	40 °C
Insulation class	B
Connection	Screw terminal
Connection type	Flexible with and without end sleeve
Max. conductor cross-section	6 – 35 mm <sup>2</sup>
Tightening torque	2.5 Nm
Insulation stripping length	17 mm
Installation	Screws
Directive	EN 61558-2-20
UL Recognized Component (CAN; USA)	Yes
Marks and test symbols	cURus, CE

Tab. 47: TEP technical data

#### Dimensions

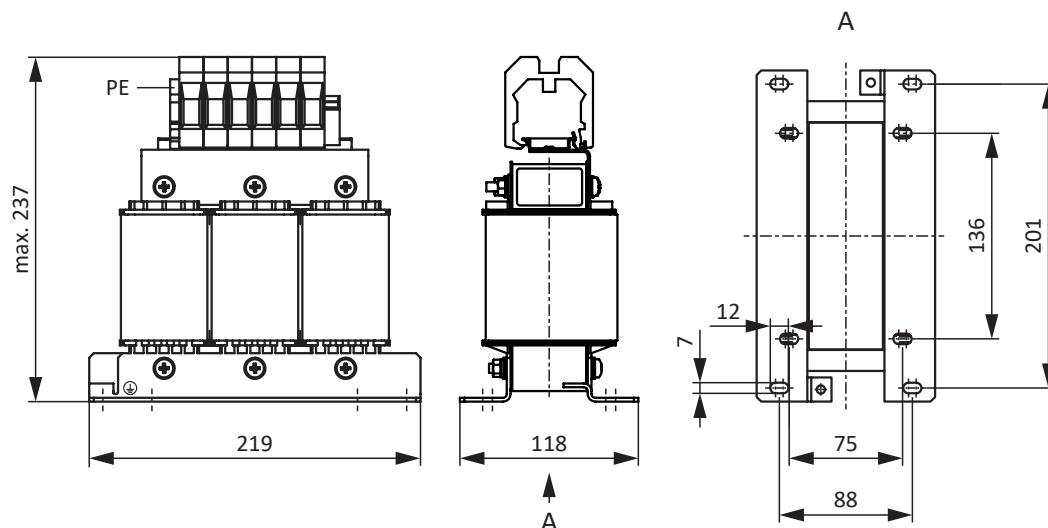

Fig. 7: Power choke dimensional drawing

Dimensions	TEP4010-2US00
Height [mm]	Max. 237
Width [mm]	219
Depth [mm]	118
Vertical distance 1 – Fastening bores [mm]	201
Vertical distance 2 – Fastening bores [mm]	136
Horizontal distance 1 – Fastening bores [mm]	88
Horizontal distance 2 – Fastening bores [mm]	75
Drill holes – Depth [mm]	7
Drill holes – Width [mm]	12
Screw connection – M	M6
Weight without packaging [g]	9900

Tab. 48: TEP dimensions and weight

### 5.4.6.2 TEP output choke

Output chokes are required for connecting size 0 to 2 drive controllers from a cable length > 50 m in order to reduce interference pulses and protect the drive system.

#### Information

The following technical data only applies to a rotating magnetic field frequency of 200 Hz. For example, this rotating magnetic field frequency is achieved with a motor with 4 pole pairs and a nominal speed of 3000 rpm. Always observe the specified derating for higher rotating magnetic field frequencies. Also observe the relationship with the clock frequency.

#### Properties

Technical data	TEP3720-0ES41	TEP3820-0CS41	TEP4020-0RS41
ID No.	53188	53189	53190
Voltage range	3 × 0 to 480 V <sub>AC</sub>		
Frequency range	0 – 200 Hz		
Nominal current I <sub>N,MF</sub> at 4 kHz	4 A	17.5 A	38 A
Nominal current I <sub>N,MF</sub> at 8 kHz	3.3 A	15.2 A	30.4 A
Max. permitted motor cable length with output choke	100 m		
Max. surrounding temperature $\vartheta_{amb,max}$	40 °C		
Protection class	IP00		
Winding losses	11 W	29 W	61 W
Iron losses	25 W	16 W	33 W
Connection	Screw terminal		
Max. conductor cross-section	10 mm <sup>2</sup>		
UL Recognized	Yes		
Component (CAN; USA)			
Marks and test symbols	cURus, CE		

Tab. 49: TEP technical data

Dimensions

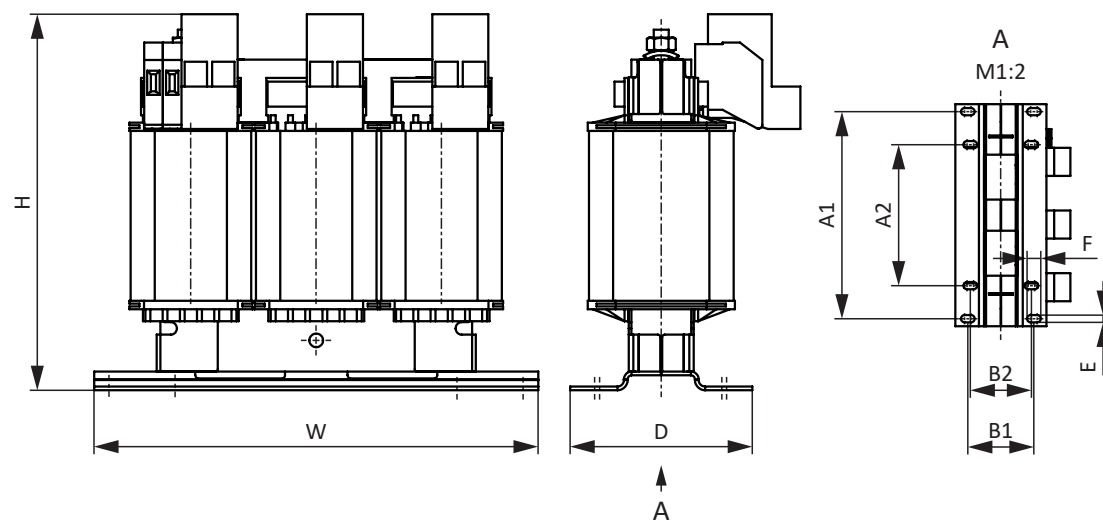

Fig. 8: TEP dimensional drawing

Dimension	TEP3720-0ES41	TEP3820-0CS41	TEP4020-0RS41
Height H [mm]	Max. 150	Max. 152	Max. 172
Width W [mm]	178	178	219
Depth D [mm]	73	88	119
Vertical distance – A1 fastening bores [mm]	166	166	201
Vertical distance – A2 fastening bores [mm]	113	113	136
Horizontal distance – B1 fastening bores [mm]	53	68	89
Horizontal distance – B2 fastening bores [mm]	49	64	76
Drill holes – Depth E [mm]	5.8	5.8	7
Drill holes – Width F [mm]	11	11	13
Screw connection – M	M5	M5	M6
Weight without packaging [g]	2900	5900	8800

Tab. 50: TEP dimensions and weight

## 5.4.7 EMC shield plate

You can use the EM6A EMC shield plate to connect the cable shield of the power cable. Two different designs are available.

### EM6A0 EMC shield plate



ID No. 135115

EMC shield plate for SB6 and SD6 series drive controllers up to size 2.

Accessory part for shield connection of the power cable.

Can be attached to the drive controller housing.

Including shield connection terminal.

### EM6A3 EMC shield plate



ID No. 135120

EMC shield plate for drive controllers of the SD6 series up to size 3.

Accessory part for shield connection of the power cable.

Can be attached to the drive controller housing.

Including shield connection terminal.

If necessary, you can also connect the cable shield of the braking resistor and DC link connection to the shield plate.

## 5.4.8 Encoder adapter box

### LA6A00 encoder adapter box



ID No. 56510

Interface adapter for differential TTL incremental signals and single-ended TTL Hall sensor signals.

The adapter converts and transmits TTL signals from synchronous linear motors to the SD6 drive controller. A variable, internal interface converts the input signals appropriately for the STOBBER standard interfaces.

### X120 SSI/TTL connecting cable



ID No. 49482

Cable for connecting the X120 interface for TTL incremental signals and SSI signals. Can be used in conjunction with the RI6 and XI6 G5 terminal modules, the SB6 XB6 terminal module and the X301 interface of the LA6 adapter box, length: 0.3 m.

### LA6 / AX 5000 connecting cable



Cable for connecting the X4 connection on the SD6 drive controller to X300 on the LA6 adapter box in order to transmit incremental encoder signals.

The following designs are available:

ID No. 45405: 0.5 m.

ID No. 45386: 2.5 m.

## 5.4.9 Removable data storage

### Paramodul removable data storage

Included in the standard version.



ID No. 56403

The plug-in Paramodul with integrated microSD card (from 512 MB, industrial type) is available as a storage medium.

## 5.5 Further information

### 5.5.1 Directives and standards

The following European directives and standards are relevant to the drive controllers:

- Directive 2006/42/EC – Machinery Directive
- Directive 2014/30/EU – EMC Directive
- Directive 2011/65/EU – RoHS Directive
- Directive 2009/125/EC – Ecodesign Directive
- EN IEC 61800-3:2018
- EN 61800-5-1:2007 + A1:2017
- EN 61800-5-2:2017
- EN 61800-9-2:2017
- EN IEC 63000:2018
- EN ISO 13849-1:2015

### 5.5.2 Marks and test symbols

The following marks and test symbols are mentioned in the technical data.



#### RoHS lead-free mark

Marking in accordance with RoHS directive 2011-65-EU.



#### CE mark

Manufacturer's self declaration: The product meets the requirements of EU directives.



#### UL test symbol (cULus)

This product is listed by UL for the United States and Canada.

Representative samples of this product have been evaluated by UL and meet the requirements of applicable standards.



#### UL recognized component mark (cURus)

This component or material is recognized by UL for the US and Canada.

Representative samples of this product have been evaluated by UL and meet applicable requirements.

### 5.5.3 Additional documentation

Additional documentation related to the product can be found at

<http://www.stoeber.de/en/downloads/>

Enter the ID of the documentation in the Search term field.

Documentation	ID
SD6 drive controller manual	442426
SE6 safety module manual	442796

## 6 Connection method

### Table of contents

6.1	Overview .....	158
6.2	Conventions for cables .....	159
6.3	Length definition for ready-made cables .....	159
6.4	One Cable Solution EnDat 3 .....	160
6.4.1	Motor assignment .....	161
6.4.2	Connection description .....	162
6.5	Power cables .....	163
6.5.1	Motor assignment .....	163
6.5.2	Connection description .....	165
6.6	Encoder cables .....	168
6.6.1	EnDat 2.1/2.2 digital encoders .....	168
6.6.2	EnDat 2.1 sin/cos encoders .....	170
6.6.3	Resolver .....	172
6.7	Additional documentation .....	173

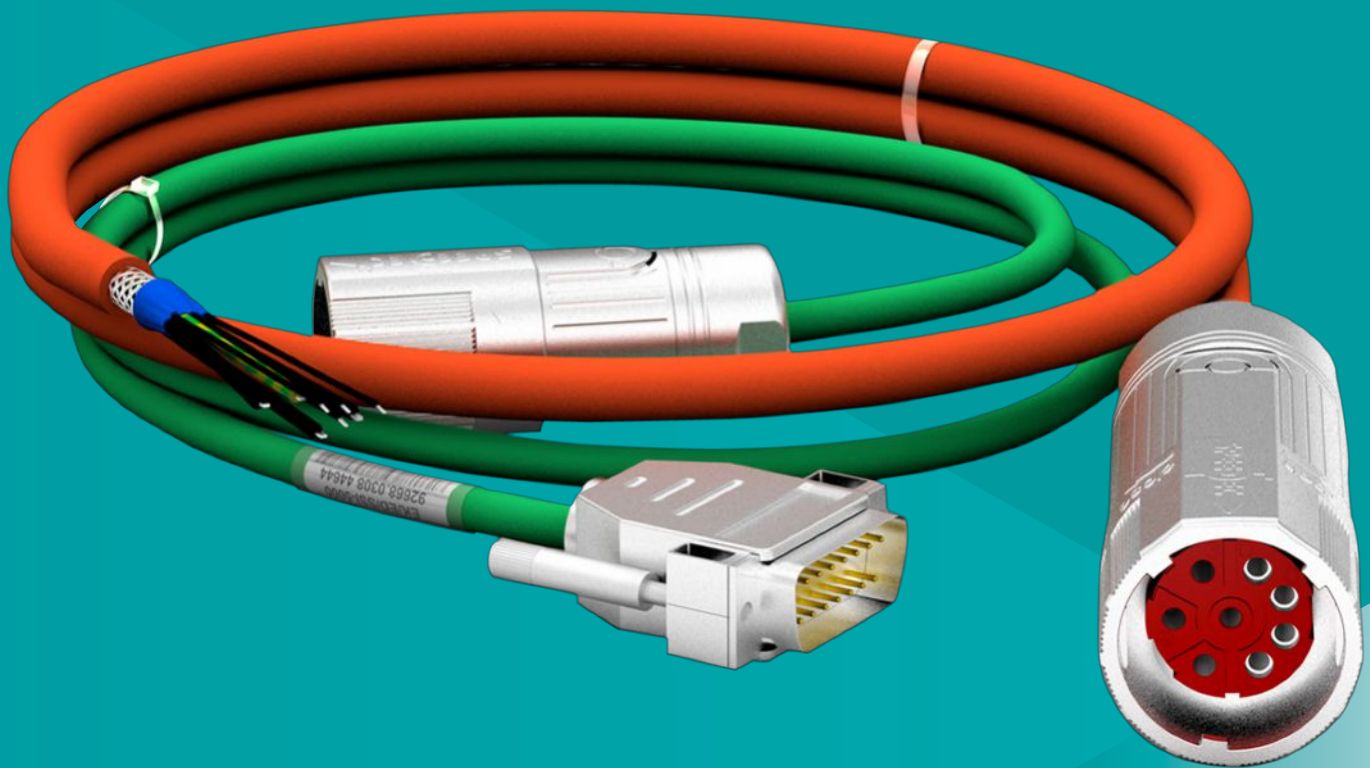

## 6 Connection method

### 6.1 Overview

Coordinated connection technology

#### Features

- One Cable Solution EnDat 3 and Hiperface DSL available
- Torsional stress  $\pm 30^\circ/\text{m}$
- Bending resistance
- Oil resistance
- Chemical resistance

A drive controller, cable and motor that are not coordinated with one another can lead to impermissibly high voltage peaks in the drive system, which may cause damage to the motor. The legal requirements of (EMC) Directive 2014/30/EU must also be observed.

The combination of STOBBER motors with STOBBER cables and STOBBER drive controllers enables compliance with legal requirements.

STOBBER offers a range of cables to match. Cables are available in different lengths and are ready-made on both ends.

## 6.2 Conventions for cables

In the cable connection descriptions, core colors are shortened and used as follows.

### Cable colors

BK:	BLACK	PK:	PINK
BN:	BROWN	RD:	RED
BU:	BLUE	VT:	VIOLET
GN:	GREEN	WH:	WHITE
GY:	GRAY	YE:	YELLOW
OG:	ORANGE		

### Formatting conventions

Two-colored core:	WHYE	WHITEYELLOW (white-yellow core)
Single-colored core:	BK/BN	BLACK/BROWN (black or brown core)
Core pair:	BU-BK	BLUE-BLACK (blue and black core)

## 6.3 Length definition for ready-made cables

The following length definitions apply to ready-made cables from STOBER.

### Encoder cables

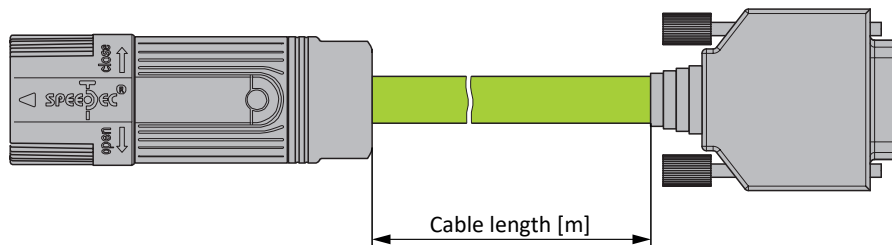

Fig. 1: Length definition for ready-made encoder cables

### Power cable

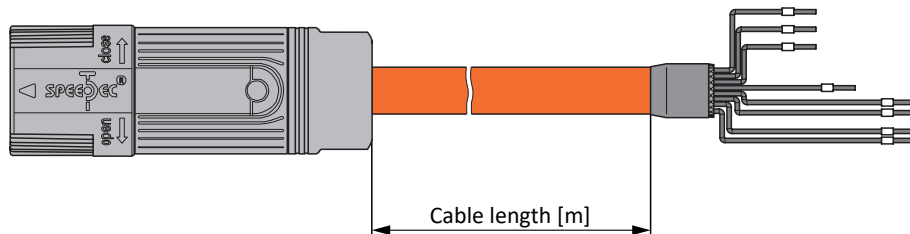

Fig. 2: Length definition for ready-made power cables – SB6, SC6, SI6

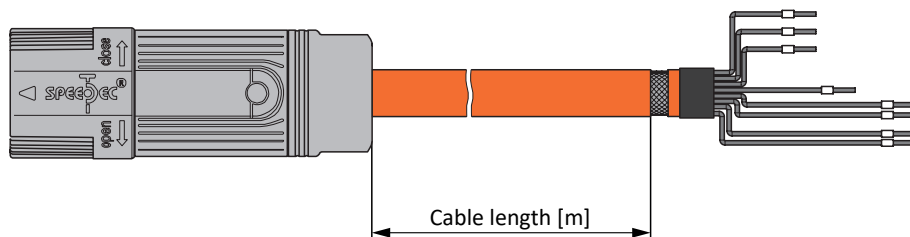

Fig. 3: Length definition for ready-made power cables – FDS 5000, MDS 5000, SDS 5000 and SD6

## One Cable Solution

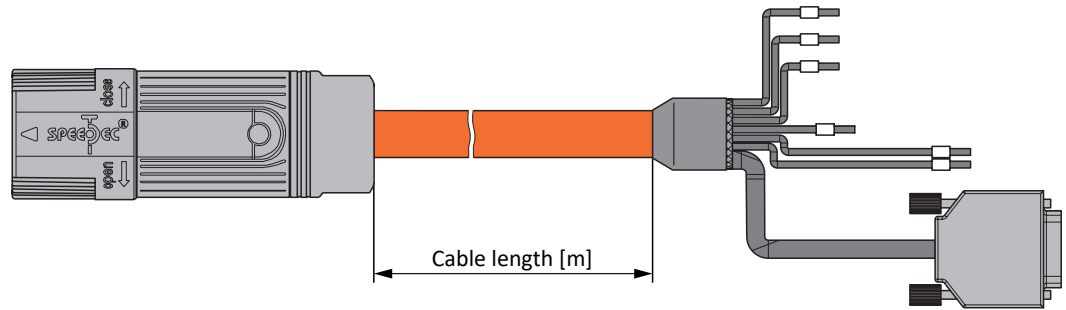

Fig. 4: Length definition for ready-made hybrid cables

## 6.4 One Cable Solution EnDat 3

The synchronous servo motors are equipped with plug connectors as standard.

A motor connection as a One Cable Solution (OCS) combined with an EnDat 3 encoder requires hybrid cables which feature encoder communication and power transmission in a shared cable.

STOBER provides suitable cables in various lengths, conductor cross-sections and connector sizes.

The cables are available ready-made in the lengths 2.5 m, 5 m, 7.5 m, 10 m, 12.5 m, 15 m, 18 m, 20 m, 25 m, 30 m, 35 m, 40 m and 50 m.

Other lengths on request.

For applications with a cable length of up to 12.5 m, conductor cross-sections of 1.0 or 1.5 mm<sup>2</sup> and a non-moving installation, STOBER recommends the OCS-Basic hybrid cables. For longer lengths or installation in moving cable runs (such as a drag chain), use the OCS-Advanced hybrid cables.

### Information

For connecting as a One Cable Solution, use exclusively hybrid cables from STOBER. The use of unsuitable cables or poorly made connections can cause subsequent damage. For this reason, we reserve the right to reject claims under the warranty in this case.

## 6.4.1 Motor assignment

STOBER offers cables with a minimum cross-section for the motors as standard. Depending on the application, however, larger conductor cross-sections may be required. For this reason, take into account the following points in addition for dimensioning the cable:

- Stall current  $I_0$  of the motor
- Permitted current carrying capacity of the conductors
- Cable length
- Terminal specifications of the drive controller or output choke
- Connector size of the motor

### EZ motors – IC 410 convection cooling

	$n_N$ 3000 rpm			$n_N$ 4500 rpm			$n_N$ 6000 rpm		
	$K_{EM}$ V/1000 rpm	Plug con. size	Minimum cross-section mm <sup>2</sup>	$K_{EM}$ V/1000 rpm	Plug con. size	Minimum cross-section mm <sup>2</sup>	$K_{EM}$ V/1000 rpm	Plug con. size	Minimum cross-section mm <sup>2</sup>
EZ202U	—	—	—	—	—	—	40	con.23	1.0 / 1.5
EZ203U	—	—	—	—	—	—	40	con.23	1.0 / 1.5
EZ301U	40	con.23	1.0 / 1.5	—	—	—	40	con.23	1.0 / 1.5
EZ302U	86	con.23	1.0 / 1.5	—	—	—	42	con.23	1.0 / 1.5
EZ303U	109	con.23	1.0 / 1.5	—	—	—	55	con.23	1.0 / 1.5
EZ401U	96	con.23	1.0 / 1.5	—	—	—	47	con.23	1.0 / 1.5
EZ402U	94	con.23	1.0 / 1.5	—	—	—	60	con.23	1.0 / 1.5
EZ404U	116	con.23	1.0 / 1.5	—	—	—	78	con.23	1.0 / 1.5
EZ501U	97	con.23	1.0 / 1.5	—	—	—	68	con.23	1.0 / 1.5
EZ502U	121	con.23	1.0 / 1.5	—	—	—	72	con.23	1.0 / 1.5
EZ503U	119	con.23	1.0 / 1.5	—	—	—	84	con.23	1.0 / 1.5
EZ505U	141	con.23	1.0 / 1.5	103	con.23	1.5	—	—	—
EZ701U	95	con.23	1.0 / 1.5	—	—	—	76	con.23	1.0 / 1.5
EZ702U	133	con.23	1.0 / 1.5	—	—	—	82	con.23	2.5
EZ703U	122	con.23	1.5	99	con.23	2.5	—	—	—
EZ705U	140	con.23	2.5	—	—	—	—	—	—

Tab. 1: Plug connector size and minimum cross-section, EZ synchronous servo motors with convection cooling

Minimum cross-section specification for motors with integrated holding brake: The smaller cross-section applies to cable lengths up to max. 12.5 m.

### EZ motors – IC 416 forced ventilation

	$n_N$ 3000 rpm			$n_N$ 4500 rpm			$n_N$ 6000 rpm		
	$K_{EM}$ V/1000 rpm	Plug con. size	Minimum cross-section mm <sup>2</sup>	$K_{EM}$ V/1000 rpm	Plug con. size	Minimum cross-section mm <sup>2</sup>	$K_{EM}$ V/1000 rpm	Plug con. size	Minimum cross-section mm <sup>2</sup>
EZ401B	96	con.23	1.0 / 1.5	—	—	—	47	con.23	1.0 / 1.5
EZ402B	94	con.23	1.0 / 1.5	—	—	—	60	con.23	1.0 / 1.5
EZ404B	116	con.23	1.0 / 1.5	—	—	—	78	con.23	1.0 / 1.5
EZ501B	97	con.23	1.0 / 1.5	—	—	—	68	con.23	1.0 / 1.5
EZ502B	121	con.23	1.0 / 1.5	—	—	—	72	con.23	1.5
EZ503B	119	con.23	1.0 / 1.5	—	—	—	84	con.23	2.5
EZ505B	141	con.23	1.5	103	con.23	1.5	—	—	—
EZ701B	95	con.23	1.0 / 1.5	—	—	—	76	con.23	1.0 / 1.5
EZ702B	133	con.23	1.0 / 1.5	—	—	—	—	—	—
EZ703B	122	con.23	2.5	—	—	—	—	—	—

Tab. 2: Plug connector size and minimum cross-section, EZ synchronous servo motors with forced ventilation

Minimum cross-section specification for motors with integrated holding brake: The smaller cross-section applies to cable lengths up to max. 12.5 m.

### 6.4.2 Connection description

The hybrid cables are available in plug connector size con.23 with a speedtec quick-lock. Depending on the drive controller, the terminal assignment may differ from the example shown here.

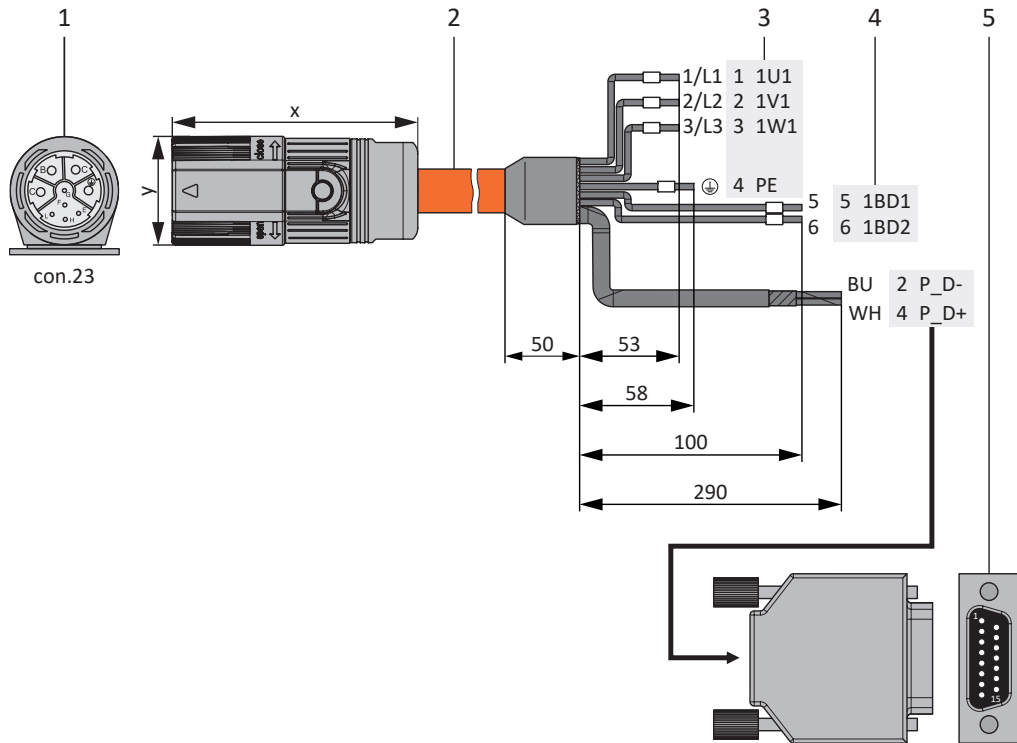

- 1 Plug connectors
- 2 Hybrid cables
- 3 Connection to terminal X20, motor
- 4 Connection of terminal X2, brake
- 5 D-sub X4

#### Hybrid cables – con.23 plug connectors

Connection diagram	Motor (1)		Cable (2)	Drive controller (3) – (5)		
	Pin	Designation		Core No./ Core color	Pin X20	Pin X2
	A	1U1	1/L1	1	—	—
	B	1V1	2/L2	2	—	—
	C	1W1	3/L3	3	—	—
	E	P_D-	BU	—	—	2
	F	P_D shield	—	—	—	Housing
	G	1BD1	5	—	5	—
	H	P_D+	WH	—	—	4
	L	1BD2	6	—	6	—
	⊕	PE	GNYE	4	—	—
	Housing	Shield	—	Shield contact	—	—

Tab. 3: con.23 hybrid cable pin assignment

Length x [mm]	Diameter y [mm]
78	26

Tab. 4: con.23 connector dimensions

## 6.5 Power cables

The synchronous servo motors are equipped with plug connectors as standard.

STOBER provides suitable cables in various lengths, conductor cross-sections and connector sizes.

The cables are available ready-made in the lengths 2.5 m, 5 m, 7.5 m, 10 m, 12.5 m, 15 m, 18 m, 20 m, 25 m, 30 m, 35 m, 40 m and 50 m.

Other lengths on request.

### 6.5.1 Motor assignment

STOBER offers cables with a minimum cross-section for the motors as standard. Depending on the application, however, larger conductor cross-sections may be required. For this reason, take into account the following points in addition for dimensioning the cable:

- Stall current  $I_0$  of the motor
- Permitted current carrying capacity of the conductors
- Cable length
- Terminal specifications of the drive controller or output choke
- Connector size of the motor

#### EZ motors – IC 410 convection cooling

	$n_N$ 2000 rpm				$n_N$ 3000 rpm				$n_N = 4000$ rpm / 4500 rpm				$n_N$ 6000 rpm			
	$K_{EM}$ [V/1000 rpm]	$I_0$ [A]	Plug con. size	Minimum cross-section [mm <sup>2</sup> ]	$K_{EM}$ [V/1000 rpm]	$I_0$ [A]	Plug con. size	Minimum cross-section [mm <sup>2</sup> ]	$K_{EM}$ [V/1000 rpm]	$I_0$ [A]	Plug con. size	Minimum cross-section [mm <sup>2</sup> ]	$K_{EM}$ [V/1000 rpm]	$I_0$ [A]	Plug con. size	Minimum cross-section [mm <sup>2</sup> ]
EZ202U	—	—	—	—	—	—	—	—	—	—	—	—	40	1.03	con.15	1.0
EZ203U	—	—	—	—	—	—	—	—	—	—	—	—	40	1.64	con.15	1.0
EZ301U	—	—	—	—	40	2.02	con.15	1.0	—	—	—	—	40	2.02	con.15	1.0
EZ302U	—	—	—	—	86	1.67	con.15	1.0	—	—	—	—	42	3.48	con.15	1.0
EZ303U	—	—	—	—	109	1.71	con.15	1.0	—	—	—	—	55	3.55	con.15	1.0
EZ401U	—	—	—	—	96	2.88	con.23	1.0 / 1.5	—	—	—	—	47	5.36	con.23	1.0 / 1.5
EZ402U	—	—	—	—	94	4.8	con.23	1.0 / 1.5	—	—	—	—	60	7.43	con.23	1.0 / 1.5
EZ404U	—	—	—	—	116	6.6	con.23	1.0 / 1.5	—	—	—	—	78	9.78	con.23	1.0 / 1.5
EZ501U	—	—	—	—	97	4	con.23	1.0 / 1.5	—	—	—	—	68	5.8	con.23	1.0 / 1.5
EZ502U	—	—	—	—	121	5.76	con.23	1.0 / 1.5	—	—	—	—	72	9.8	con.23	1.0 / 1.5
EZ503U	—	—	—	—	119	7.67	con.23	1.0 / 1.5	—	—	—	—	84	11.6	con.23	1.0 / 1.5
EZ505U	—	—	—	—	141	10	con.23	1.0 / 1.5	103	13.4	con.23	1.5	—	—	—	—
EZ701U	—	—	—	—	95	8	con.23	1.0 / 1.5	—	—	—	—	76	9.38	con.23	1.0 / 1.5
EZ702U	—	—	—	—	133	9.6	con.23	1.0 / 1.5	—	—	—	—	82	16.5	con.23	2.5
EZ703U	—	—	—	—	122	14	con.23	1.5	99	17.8	con.23	2.5	—	—	—	—
EZ705U	—	—	—	—	140	19.5	con.40	2.5	106	25.2	con.40	4.0	—	—	—	—
EZ813U	239	16.5	con.40	2.5	—	—	—	—	117	32.8	con.40	6.0	—	—	—	—
EZ815U	239	25.2	con.40	4.0	—	—	—	—	117	50.3	con.40	10.0	—	—	—	—

Tab. 5: Plug connector size and minimum cross-section, EZ synchronous servo motors with convection cooling

Minimum cross-section specification for motors with integrated holding brake: The smaller cross-section applies to cable lengths up to max. 12.5 m.

## EZ motors – IC 416 forced ventilation

	n <sub>N</sub> 2000 rpm				n <sub>N</sub> 3000 rpm				n <sub>N</sub> = 4000 rpm / 4500 rpm				n <sub>N</sub> 6000 rpm			
	K <sub>EM</sub> [V/1000 rpm]	I <sub>0</sub> [A]	Plug con. size	Minimum cross-section [mm <sup>2</sup> ]	K <sub>EM</sub> [V/1000 rpm]	I <sub>0</sub> [A]	Plug con. size	Minimum cross-section [mm <sup>2</sup> ]	K <sub>EM</sub> [V/1000 rpm]	I <sub>0</sub> [A]	Plug con. size	Minimum cross-section [mm <sup>2</sup> ]	K <sub>EM</sub> [V/1000 rpm]	I <sub>0</sub> [A]	Plug con. size	Minimum cross-section [mm <sup>2</sup> ]
EZ401B	—	—	—	—	96	3.6	con.23	1.0 / 1.5	—	—	—	—	47	6.83	con.23	1.0 / 1.5
EZ402B	—	—	—	—	94	5.8	con.23	1.0 / 1.5	—	—	—	—	60	9.34	con.23	1.0 / 1.5
EZ404B	—	—	—	—	116	8.7	con.23	1.0 / 1.5	—	—	—	—	78	12	con.23	1.0 / 1.5
EZ501B	—	—	—	—	97	5	con.23	1.0 / 1.5	—	—	—	—	68	7.5	con.23	1.0 / 1.5
EZ502B	—	—	—	—	121	8.16	con.23	1.0 / 1.5	—	—	—	—	72	13.4	con.23	1.5
EZ503B	—	—	—	—	119	11.8	con.23	1.0 / 1.5	—	—	—	—	84	15.9	con.23	2.5
EZ505B	—	—	—	—	141	14.7	con.23	1.5	103	19.4	con.23	2.5	—	—	—	—
EZ701B	—	—	—	—	95	10	con.23	1.0 / 1.5	—	—	—	—	76	12.4	con.23	1.0 / 1.5
EZ702B	—	—	—	—	133	12.9	con.23	1.0 / 1.5	—	—	—	—	82	22.1	con.23	2.5 / 4.0
EZ703B	—	—	—	—	122	20	con.23	2.5	99	24.2	con.23	4.0	—	—	—	—
EZ705B	—	—	—	—	140	26.5	con.40	4.0	106	32.8	con.40	6.0	—	—	—	—
EZ813B	239	22.9	con.40	4.0	—	—	—	—	117	46.6	con.40	10.0	—	—	—	—
EZ815B	239	36.3	con.40	6.0	—	—	—	—	117	65.0	con.40	16.0	—	—	—	—

Tab. 6: Plug connector size and minimum cross-section, EZ synchronous servo motors with forced ventilation

Minimum cross-section specification for motors with integrated holding brake: The smaller cross-section applies to cable lengths up to max. 12.5 m.

## 6.5.2 Connection description

Depending on the size of the motor plug connector, power cables are available in the following designs:

- Quick-lock for con.15
- speedtec quick-lock for con.23 and con.40

### Information

Observe the designations on the identification clips for the correct connection of the cores.

### Information

The design of the cable shield connection on the controller side depends on the drive controller series.

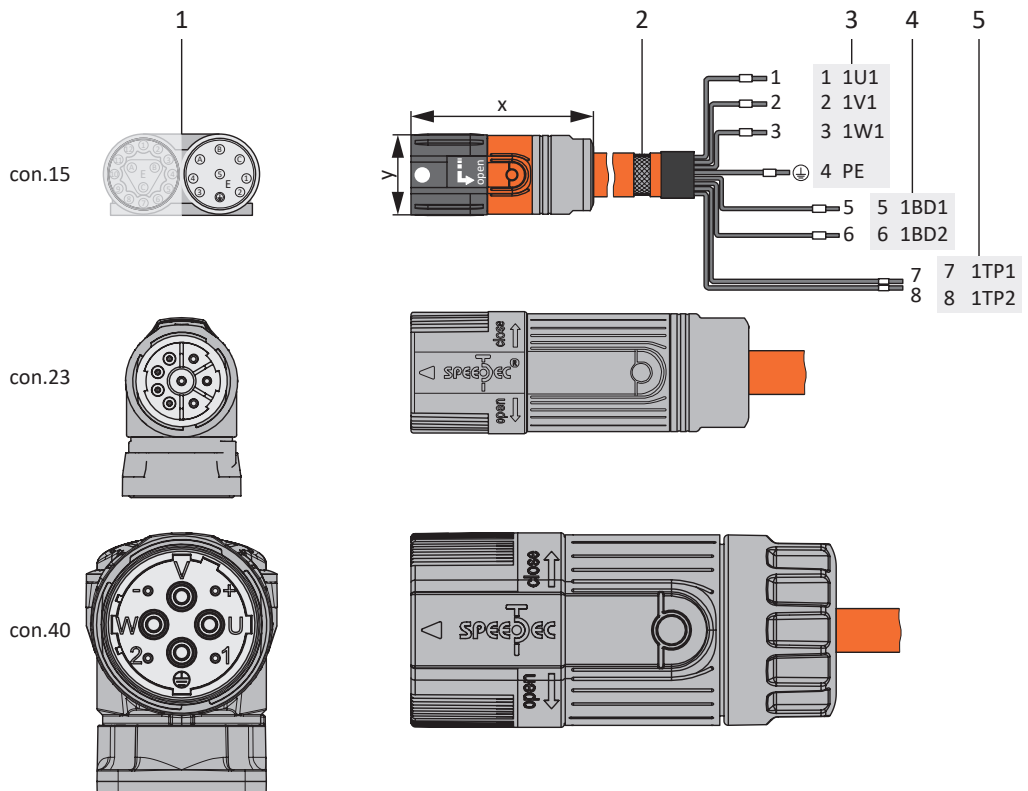

- 1 Plug connectors
- 2 Power cable, cable shield
- 3 Connection to terminal X20, motor
- 4 Connection of terminal X2/X5, brake
- 5 Connection to terminal X2, temperature sensor

### Maximum cable length

Connection	Size 0 to 2	Size 3
Without output choke	50 m, shielded	100 m, shielded
With output choke	100 m, shielded	—

Tab. 7: Maximum cable length of the power cable [m]

Power cables – con.15 plug connector

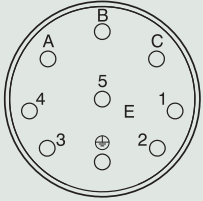
Motor connection diagram	Motor (1)		Cable (2) Identification/ Core color	Drive controller (3) – (5)		
	Pin	Designation		Pin X20	Pin X2/X5	Pin X2
	A	1U1	1	1	—	—
	B	1V1	2	2	—	—
	C	1W1	3	3	—	—
	1	1TP1	7	—	—	7
	2	1TP2	8	—	—	8
	3	1BD1	5	—	5	—
	4	1BD2	6	—	6	—
	5	—	—	—	—	—
		PE	GNYE	4	—	—
	Housing	Shield	—	Shield contact	—	—

Tab. 8: con.15 power cable pin assignment

Length x [mm]	Diameter y [mm]
42	18.7

Tab. 9: con.15 connector dimensions

Power cables – con.23 plug connector

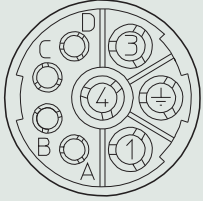
Motor connection diagram	Motor (1)		Cable (2) Identification/ Core color	Drive controller (3) – (5)		
	Pin	Designation		Pin X20	Pin X2/X5	Pin X2
	1	1U1	1	1	—	—
	3	1V1	2	2	—	—
	4	1W1	3	3	—	—
	A	1BD1	5	—	5	—
	B	1BD2	6	—	6	—
	C	1TP1	7	—	—	7
	D	1TP2	8	—	—	8
		PE	GNYE	4	—	—
	Housing	Shield	—	Shield contact	—	—

Tab. 10: con.23 power cable pin assignment

Length x [mm]	Diameter y [mm]
78	26

Tab. 11: con.23 connector dimensions

## Power cables – con.40 plug connector

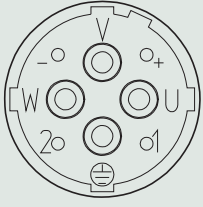
Motor connection diagram	Motor (1)		Cable (2)	Drive controller (3) – (5)		
	Pin	Designation	Identification/ Core color	Pin X20	Pin X2/X5	Pin X2
	U	1U1	1	1	—	—
	V	1V1	2	2	—	—
	W	1W1	3	3	—	—
	+	1BD1	5	—	5	—
	-	1BD2	6	—	6	—
	1	1TP1	7	—	—	7
	2	1TP2	8	—	—	8
	⊕	PE	GNYE	4	—	—
	Housing	Shield	—	Shield con- tact	—	—

Tab. 12: con.40 power cable pin assignment

Length x [mm]	Diameter y [mm]
99	46

Tab. 13: con.40 connector dimensions

## 6.6 Encoder cables

The motors are equipped with encoder systems and plug connectors as standard.

STOBER provides suitable cables in various lengths, conductor cross-sections and connector sizes.

The cables are available ready-made in the lengths 2.5 m, 5 m, 7.5 m, 10 m, 12.5 m, 15 m, 18 m, 20 m, 25 m, 30 m, 35 m, 40 m and 50 m.

Other lengths on request.

### 6.6.1 EnDat 2.1/2.2 digital encoders

Suitable encoder cables are described below.

#### 6.6.1.1 Connection description

Depending on the size of the motor plug connector, encoder cables are available in the following designs:

- Quick-lock for con.15
- speedtec quick-lock for con.17

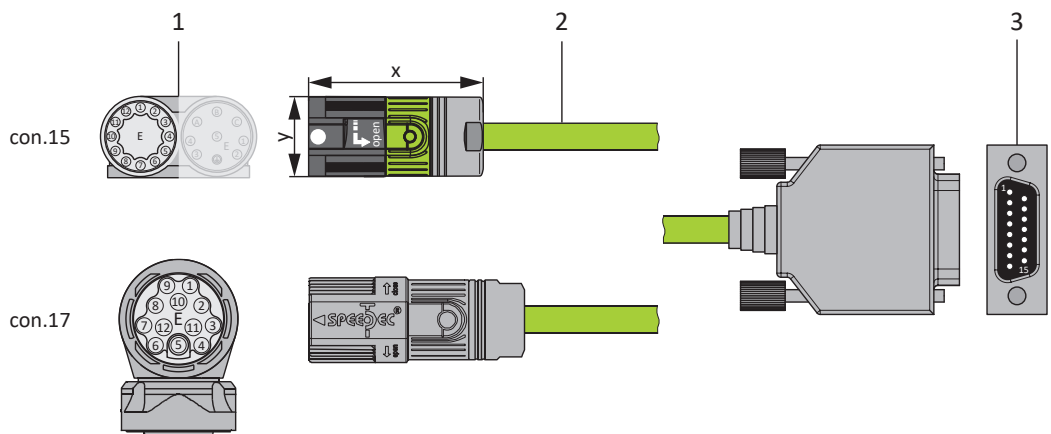

- 1 Plug connectors
- 2 Encoder cables
- 3 D-sub X4/X140

#### Encoder cables – con.15 plug connectors

Connection diagram	Motor (1)		Cable (2)	Drive controller (3)
	Pin	Designation	Core color	Pin X4/X140
	1	Clock +	YE	8
	2	Up sense	PK	12
	3	—	—	—
	4	—	—	—
	5	Data –	BN	13
	6	Data +	WH	5
	7	—	—	—
	8	Clock –	GN	15
	9	—	—	—
	10	0 V GND	BU	2
	11	—	—	—
	12	U <sub>2</sub>	RD	4
	Housing	Shield	—	Housing

Tab. 14: con.15 encoder cable pin assignment, EnDat 2.1/2.2 digital

Length x [mm]	Diameter y [mm]
42	18.7

Tab. 15: con.15 connector dimensions

## Encoder cables – con.17 plug connectors

Connection diagram	Motor (1)		Cable (2)	Drive controller (3)
	Pin	Designation	Core color	Pin X4/X140
	1	Clock +	YE	8
	2	Up sense	PK	12
	3	—	—	—
	4	—	—	—
	5	Data -	BN	13
	6	Data +	WH	5
	7	—	—	—
	8	Clock -	GN	15
	9	—	—	—
	10	0 V GND	BU	2
	11	—	—	—
	12	U <sub>2</sub>	RD	4
	Housing	Shield	—	Housing

Tab. 16: con.17 encoder cable pin assignment, EnDat 2.1/2.2 digital

Length x [mm]	Diameter y [mm]
56	22

Tab. 17: con.17 connector dimensions

## 6.6.2 EnDat 2.1 sin/cos encoders

Suitable encoder cables are described below.

### 6.6.2.1 Connection description

Depending on the size of the motor plug connector, encoder cables are available in the following designs:

- Quick-lock for con.15
- speedtec quick-lock for con.17

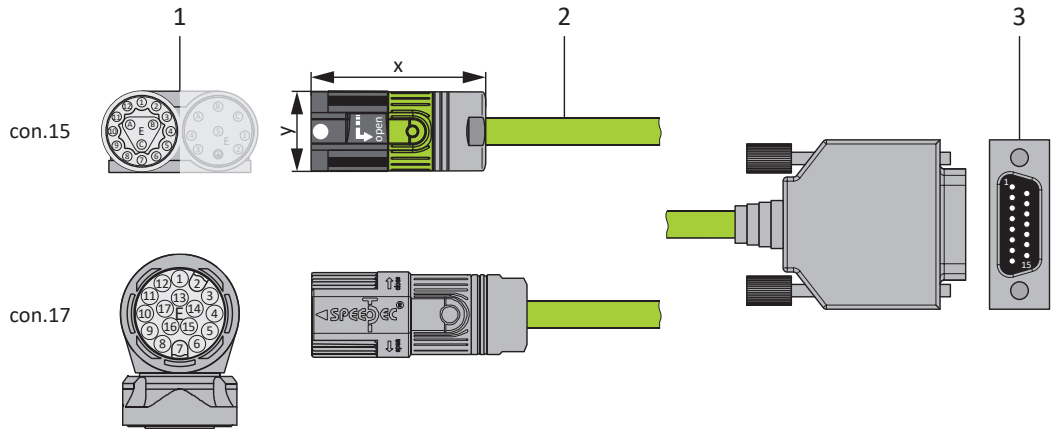

- 1 Plug connectors
- 2 Encoder cables
- 3 D-sub X140

#### Information

For connecting EnDat 2.1 sin/cos cables with a 15-pin D-sub connector to an integrated motor temperature sensor, you must use the AP6A02 interface adapter (ID No. 56523), available separately, to lead out the temperature sensor cores.

#### Encoder cables – con.15 plug connectors

Connection diagram	Motor (1)		Cable (2)	Drive controller (3)
	Pin	Designation	Core color	Pin X140
	1	U <sub>2</sub> Sense	GNRD	12
	2	0 V Sense	GNBK	10
	3	U <sub>2</sub>	BNRD	4
	4	Clock +	WHBK	8
	5	Clock -	WHYE	15
	6	0 V GND	BNBU	2
	7	B + (Sin +)	RD	9
	8	B - (Sin -)	OG	1
	9	Data +	GY	5
	10	A + (Cos +)	GN	11
	11	A - (Cos -)	YE	3
	12	Data -	BU	13
	A	1TP2	BNGY	14
B	1TP1	BNYE	7	
C	—	—	—	
Housing	Shield	—	Housing	

Tab. 18: con.15 encoder cable pin assignment, EnDat 2.1 sin/cos

Length x [mm]	Diameter y [mm]
42	18.7

Tab. 19: con.15 connector dimensions

## Encoder cables – con.17 plug connectors

Connection diagram	Motor (1)		Cable (2)	Drive controller (3)
	Pin	Designation	Core color	Pin X140
	1	U <sub>2</sub> Sense	GNRD	12
	2	—	—	—
	3	—	—	—
	4	0 V Sense	GNBK	10
	5	1TP2	BNGY	14
	6	1TP1	BNYE	7
	7	U <sub>2</sub>	BNRD	4
	8	Clock +	WHBK	8
	9	Clock -	WHYE	15
	10	0 V GND	BNBU	2
	11	—	—	—
	12	B + (Sin +)	RD	9
	13	B - (Sin -)	OG	1
	14	Data +	GY	5
	15	A + (Cos +)	GN	11
	16	A - (Cos -)	YE	3
	17	Data -	BU	13
	Housing	Shield	—	Housing

Tab. 20: con.17 encoder cable pin assignment, EnDat 2.1 sin/cos

Length x [mm]	Diameter y [mm]
56	22

Tab. 21: con.17 connector dimensions

### 6.6.3 Resolver

Suitable encoder cables are described below.

#### 6.6.3.1 Connection description

Depending on the size of the motor plug connector, encoder cables are available in the following designs:

- Quick-lock for con.15
- speedtec quick-lock for con.17

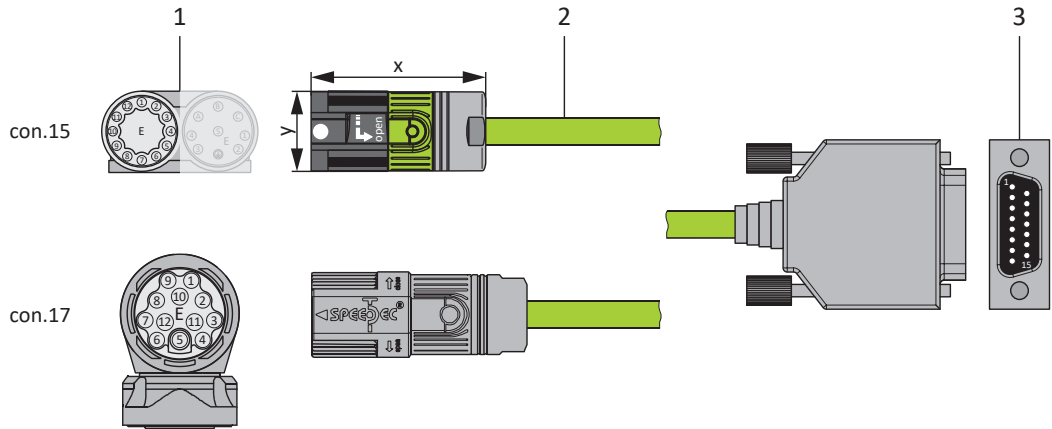

- 1 Plug connectors
- 2 Encoder cables
- 3 D-sub X4/X140

#### Encoder cables – con.15 plug connectors

Connection diagram	Motor (1)		Cable (2)		Drive controller (3)
	Pin	Designation	Core color	Pair	Pin X4/X140
	1	S3 Cos +	GN	GN-BK	3
	2	S1 Cos -	BK	GN-BK	11
	3	S4 Sin +	WH	WH-BK	1
	4	S2 Sin -	BK	WH-BK	9
	5	1TP1	RD	RD-BK	7
	6	1TP2	BK	RD-BK	14
	7	R2 Ref +	BU	BU-BK	6
	8	R1 Ref -	BK	BU-BK	2
	9	—	—	—	—
	10	—	—	—	—
	11	—	—	—	—
	12	—	—	—	—
Housing	Shield	—	—	Housing	

Tab. 22: Encoder cable pin assignment con.15, resolver, "Motion Resolver" cable label

Length x [mm]	Diameter y [mm]
42	18.7

Tab. 23: con.15 connector dimensions

## Encoder cables – con.17 plug connectors

Connection diagram	Motor (1)		Cable (2)		Drive controller (3)
	Pin	Designation	Core color	Pair	Pin X4/X140
	1	S3 Cos +	GN	GN-BK	3
	2	S1 Cos -	BK	GN-BK	11
	3	S4 Sin +	WH	WH-BK	1
	4	S2 Sin -	BK	WH-BK	9
	5	1TP1	RD	RD-BK	7
	6	1TP2	BK	RD-BK	14
	7	R2 Ref +	BU	BU-BK	6
	8	R1 Ref -	BK	BU-BK	2
	9	—	—	—	—
	10	—	—	—	—
	11	—	—	—	—
	12	—	—	—	—
	Housing	Shield	—	—	Housing

Tab. 24: Encoder cable pin assignment con.17, resolver, "Motion Resolver" cable label

Length x [mm]	Diameter y [mm]
56	22

Tab. 25: con.17 connector dimensions

## 6.7 Additional documentation

Additional documentation related to the product can be found at

<http://www.stoeber.de/en/downloads/>

Enter the ID of the documentation in the Search term field.

Documentation	ID
Connection method manual	443102



# 7 EZ synchronous servo motors

## Table of contents

7.1	Overview .....	176
7.2	Selection tables .....	177
7.2.1	EZ motors with convection cooling .....	178
7.2.2	EZ motors with forced ventilation .....	179
7.3	Torque/speed curves .....	180
7.4	Dimensional drawings .....	190
7.4.1	EZ2 – EZ3 motors with convection cooling (One Cable Solution) .....	190
7.4.2	EZ2 – EZ3 motors with convection cooling .....	191
7.4.3	EZ4 – EZ7 motors with convection cooling (One Cable Solution) .....	192
7.4.4	EZ4 – EZ8 motors with convection cooling .....	193
7.4.5	EZ4 – EZ7 motors with forced ventilation (One Cable Solution) .....	194
7.4.6	EZ4 – EZ8 motors with forced ventilation .....	195
7.5	Type designation .....	196
7.5.1	Nameplate .....	197
7.6	Product description .....	198
7.6.1	General features .....	198
7.6.2	Electrical features .....	198
7.6.3	Ambient conditions .....	198
7.6.4	Encoders .....	199
7.6.5	Temperature sensor .....	201
7.6.6	Cooling .....	203
7.6.7	Holding brake .....	204
7.6.8	Connection method .....	206
7.7	Project configuration .....	211
7.7.1	Drive selection .....	212
7.7.2	Permitted shaft loads .....	214
7.7.3	Derating .....	215
7.8	Further information .....	216
7.8.1	Directives and standards .....	216
7.8.2	Identifiers and test symbols .....	216
7.8.3	Additional documentation .....	216

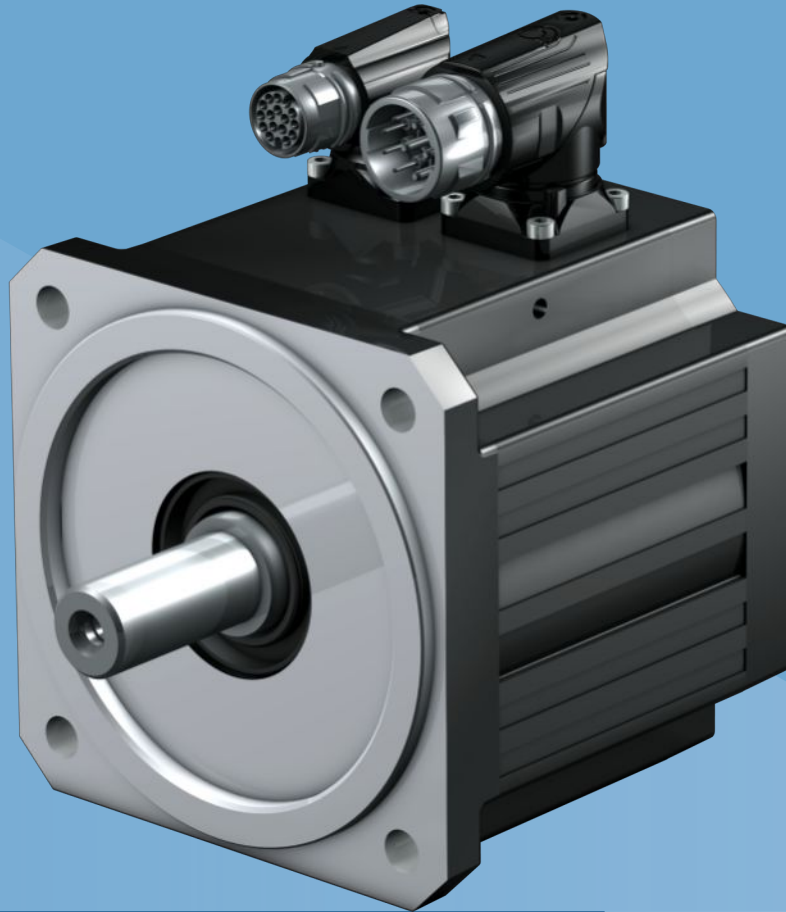

# 7

## Synchronous servo motors

EZ

### 7.1 Overview

Synchronous servo motors with tooth winding

#### Features

- High dynamics ✓
- Short length ✓
- Super compact due to tooth-coil winding method with the highest possible copper fill factor ✓
- Backlash-free holding brake (optional) ✓
- Electronic nameplate for fast and reliable commissioning ✓
- Convection cooling or forced ventilation (optional) ✓
- Optical, inductive EnDat absolute encoders or resolvers ✓
- Elimination of referencing with multi-turn absolute encoders (optional) ✓
- One Cable Solution (OCS) with EnDat 3 encoder (optional) ✓
- Rotatable plug connectors<sup>1</sup> with quick-lock ✓

<sup>1</sup>The plug connectors can be pivoted up to 10 times at a specific angle. They cannot be rotated repeatedly.

#### Torques

$M_N$	0.4 – 91 Nm
$M_0$	0.44 – 100 Nm

## 7.2 Selection tables

The technical data specified in the selection tables applies to:

- Installation altitudes up to 1000 m above sea level
- Surrounding temperatures from  $-15\text{ °C}$  to  $+40\text{ °C}$
- Operation on a STOBBER drive controller
- DC link voltage  $U_{zk} = \text{DC } 540\text{ V}$
- Coating: RAL 9005 Jet black, matte

In addition, the technical data applies to an uninsulated design with the following thermal mounting conditions:

Type	Dimensions of steel mounting flange (thickness x width x height)	Convection surface area Steel mounting flange
EZ2 – EZ5	23 x 210 x 275 mm	0.14 m <sup>2</sup>
EZ7 – EZ8	28 x 300 x 400 mm	0.3 m <sup>2</sup>

Note the differing ambient conditions in Chapter [▶ 7.7.3](#)

### Formula symbols

Observe the additional information on the following formula symbols:

- $I_0$  = RMS value of the line-to-line current when stall torque  $M_0$  is generated (tolerance  $\pm 5\%$ ).
- $I_{\max}$  = RMS value of the short-term maximum permitted line-to-line current when maximum torque  $M_{\max}$  is generated (tolerance  $\pm 5\%$ ). Exceeding  $I_{\max}$  may lead to irreversible damage (demagnetization) of the rotor.
- $I_N$  = RMS value of the line-to-line current when nominal torque  $M_N$  is generated at the nominal point (tolerance  $\pm 5\%$ ).
- $M_0$  = Torque that a motor is continuously able to deliver at a speed of 10 rpm (tolerance  $\pm 5\%$ ). At a speed of 0 rpm, a minor continuous torque has to be taken into account. Contact your STOBBER customer advisor for such an application.

## 7.2.1 EZ motors with convection cooling

Type	$K_{EM}$ [V/1000 min <sup>-1</sup> ]	$n_N$ [rpm]	$M_N$ [Nm]	$I_N$ [A]	$K_{M,N}$ [Nm/A]	$P_N$ [kW]	$M_0$ [Nm]	$I_0$ [A]	$K_{M0}$ [Nm/A]	$M_R$ [Nm]	$M_{max}$ [Nm]	$I_{max}$ [A]	$R_{U-V}$ [Ω]	$L_{U-V}$ [mH]	$T_{el}$ [ms]	$J_{dyn}$ [kgcm <sup>2</sup> ]	$m_{dyn}$ [kg]
EZ202U	40	6000	0.40	0.99	0.41	0.25	0.44	1.03	0.45	0.03	1.48	3.48	26.0	15.80	0.61	0.13	1.4
EZ203U	40	6000	0.61	1.54	0.40	0.38	0.69	1.64	0.44	0.03	2.70	5.80	13.2	10.30	0.76	0.17	1.7
EZ301U	40	6000	0.89	1.93	0.46	0.56	0.95	2.02	0.49	0.04	2.80	12.7	11.7	39.80	3.4	0.19	1.5
EZ301U	40	3000	0.93	1.99	0.47	0.29	0.95	2.02	0.49	0.04	2.80	12.7	11.7	39.80	3.4	0.19	1.5
EZ302U	42	6000	1.50	3.18	0.47	0.94	1.68	3.48	0.49	0.04	5.00	17.8	4.50	18.70	4.2	0.29	2.1
EZ302U	86	3000	1.59	1.60	0.99	0.50	1.68	1.67	1.03	0.04	5.00	8.55	17.8	75.00	4.2	0.29	2.1
EZ303U	55	6000	1.96	3.17	0.62	1.2	2.25	3.55	0.65	0.04	7.00	16.9	4.90	21.10	4.3	0.40	2.6
EZ303U	109	3000	2.07	1.63	1.27	0.65	2.19	1.71	1.30	0.04	7.00	8.25	20.3	68.70	5.2	0.40	2.6
EZ401U	47	6000	2.30	4.56	0.50	1.4	2.80	5.36	0.53	0.04	8.50	33.0	1.94	11.52	5.9	0.93	4.0
EZ401U	96	3000	2.80	2.74	1.02	0.88	3.00	2.88	1.06	0.04	8.50	16.5	6.70	37.70	5.6	0.93	4.0
EZ402U	60	6000	3.50	5.65	0.62	2.2	4.90	7.43	0.66	0.04	16.0	43.5	1.20	8.88	7.4	1.63	5.1
EZ402U	94	3000	4.70	4.40	1.07	1.5	5.20	4.80	1.09	0.04	16.0	26.5	3.00	21.80	7.3	1.63	5.1
EZ404U	78	6000	5.80	7.18	0.81	3.6	8.40	9.78	0.86	0.04	29.0	51.0	0.89	7.07	7.9	2.98	7.2
EZ404U	116	3000	6.90	5.80	1.19	2.2	8.60	6.60	1.31	0.04	29.0	35.0	1.85	15.00	8.1	2.98	7.2
EZ501U	68	6000	3.40	4.77	0.71	2.1	4.40	5.80	0.77	0.06	16.0	31.0	2.10	12.10	5.8	2.90	5.0
EZ501U	97	3000	4.30	3.74	1.15	1.4	4.70	4.00	1.19	0.06	16.0	22.0	3.80	23.50	6.2	2.90	5.0
EZ502U	72	6000	5.20	7.35	0.71	3.3	7.80	9.80	0.80	0.06	31.0	59.0	0.76	5.60	7.4	5.20	6.5
EZ502U	121	3000	7.40	5.46	1.36	2.3	8.00	5.76	1.40	0.06	31.0	33.0	2.32	16.80	7.2	5.20	6.5
EZ503U	84	6000	6.20	7.64	0.81	3.9	10.6	11.6	0.92	0.06	43.0	63.5	0.62	5.00	8.1	7.58	8.0
EZ503U	119	3000	9.70	6.90	1.41	3.1	11.1	7.67	1.46	0.06	43.0	41.0	1.25	10.00	8.0	7.58	8.0
EZ505U	103	4500	9.50	8.94	1.06	4.5	15.3	13.4	1.15	0.06	67.0	73.0	0.50	4.47	8.9	12.2	11
EZ505U	141	3000	13.5	8.80	1.53	4.2	16.0	10.0	1.61	0.06	67.0	52.0	0.93	8.33	9.0	12.2	11
EZ701U	76	6000	5.20	6.68	0.78	3.3	7.90	9.38	0.87	0.24	20.0	31.0	0.87	8.13	9.3	8.50	8.3
EZ701U	95	3000	7.40	7.20	1.03	2.3	8.30	8.00	1.07	0.24	20.0	25.0	1.30	12.83	9.9	8.50	8.3
EZ702U	82	6000	7.20	8.96	0.80	4.5	14.3	16.5	0.88	0.24	41.0	60.5	0.34	3.90	11	13.7	11
EZ702U	133	3000	12.0	8.20	1.46	3.8	14.4	9.60	1.53	0.24	41.0	36.0	1.00	11.73	12	13.7	11
EZ703U	99	4500	12.1	11.5	1.05	5.7	20.0	17.8	1.14	0.24	65.0	78.0	0.36	4.42	12	21.6	13
EZ703U	122	3000	16.5	11.4	1.45	5.2	20.8	14.0	1.50	0.24	65.0	62.0	0.52	6.80	13	21.6	13
EZ705U	106	4500	16.4	14.8	1.11	7.7	30.0	25.2	1.20	0.24	104	114	0.22	2.76	13	34.0	18
EZ705U	140	3000	21.3	14.2	1.50	6.7	30.2	19.5	1.56	0.24	104	87.0	0.33	4.80	15	34.0	18
EZ813U	117	4000	25.2	19.8	1.27	11	43.7	32.8	1.34	0.30	140	130	0.13	1.20	9.1	104	36
EZ813U	239	2000	39.0	14.9	2.62	8.1	43.7	16.5	2.67	0.30	140	64.9	0.69	5.10	7.4	104	36
EZ815U	117	4000	26.1	20.9	1.25	11	67.1	50.3	1.34	0.30	200	169	0.04	0.72	18	167	48
EZ815U	239	2000	57.8	21.5	2.68	12	68.8	25.2	2.74	0.30	200	92.4	0.40	3.63	9.1	167	48

## 7.2.2 EZ motors with forced ventilation

Type	$K_{EM}$ [V/1000 min <sup>-1</sup> ]	$n_N$ [rpm]	$M_N$ [Nm]	$I_N$ [A]	$K_{M,N}$ [Nm/A]	$P_N$ [kW]	$M_0$ [Nm]	$I_0$ [A]	$K_{M0}$ [Nm/A]	$M_R$ [Nm]	$M_{max}$ [Nm]	$I_{max}$ [A]	$R_{U-V}$ [Ω]	$L_{U-V}$ [mH]	$T_{el}$ [ms]	$J_{dyn}$ [kgcm <sup>2</sup> ]	$m_{dyn}$ [kg]
EZ401B	47	6000	2.90	5.62	0.52	1.8	3.50	6.83	0.52	0.04	8.50	33.0	1.94	11.52	5.9	0.93	5.4
EZ401B	96	3000	3.40	3.40	1.00	1.1	3.70	3.60	1.04	0.04	8.50	16.5	6.70	37.70	5.6	0.93	5.4
EZ402B	60	6000	5.10	7.88	0.65	3.2	6.40	9.34	0.69	0.04	16.0	43.5	1.20	8.88	7.4	1.63	6.5
EZ402B	94	3000	5.90	5.50	1.07	1.9	6.30	5.80	1.09	0.04	16.0	26.5	3.00	21.80	7.3	1.63	6.5
EZ404B	78	6000	8.00	9.98	0.80	5.0	10.5	12.0	0.88	0.04	29.0	51.0	0.89	7.07	7.9	2.98	8.6
EZ404B	116	3000	10.2	8.20	1.24	3.2	11.2	8.70	1.29	0.04	29.0	35.0	1.85	15.00	8.1	2.98	8.6
EZ501B	68	6000	4.50	6.70	0.67	2.8	5.70	7.50	0.77	0.06	16.0	31.0	2.10	12.10	5.8	2.90	7.0
EZ501B	97	3000	5.40	4.70	1.15	1.7	5.80	5.00	1.17	0.06	16.0	22.0	3.80	23.50	6.2	2.90	7.0
EZ502B	72	6000	8.20	11.4	0.72	5.2	10.5	13.4	0.79	0.06	31.0	59.0	0.76	5.60	7.4	5.20	8.5
EZ502B	121	3000	10.3	7.80	1.32	3.2	11.2	8.16	1.38	0.06	31.0	33.0	2.32	16.80	7.2	5.20	8.5
EZ503B	84	6000	10.4	13.5	0.77	6.5	14.8	15.9	1.07	0.06	43.0	63.5	0.62	5.00	8.1	7.58	10
EZ503B	119	3000	14.4	10.9	1.32	4.5	15.9	11.8	1.35	0.06	43.0	41.0	1.25	10.00	8.0	7.58	10
EZ505B	103	4500	16.4	16.4	1.00	7.7	22.0	19.4	1.14	0.06	67.0	73.0	0.50	4.47	8.9	12.2	13
EZ505B	141	3000	20.2	13.7	1.47	6.4	23.4	14.7	1.60	0.06	67.0	52.0	0.93	8.33	9.0	12.2	13
EZ701B	76	6000	7.50	10.6	0.71	4.7	10.2	12.4	0.84	0.24	20.0	31.0	0.87	8.13	9.3	8.50	11
EZ701B	95	3000	9.70	9.50	1.02	3.1	10.5	10.0	1.07	0.24	20.0	25.0	1.30	12.83	9.9	8.50	11
EZ702B	82	6000	12.5	16.7	0.75	7.9	19.3	22.1	0.89	0.24	41.0	60.5	0.34	3.90	11	13.7	14
EZ702B	133	3000	16.6	11.8	1.41	5.2	19.3	12.9	1.51	0.24	41.0	36.0	1.00	11.73	12	13.7	14
EZ703B	99	4500	19.8	20.3	0.98	9.3	27.2	24.2	1.13	0.24	65.0	78.0	0.36	4.42	12	21.6	16
EZ703B	122	3000	24.0	18.2	1.32	7.5	28.0	20.0	1.41	0.24	65.0	62.0	0.52	6.80	13	21.6	16
EZ705B	106	4500	27.7	25.4	1.09	13	39.4	32.8	1.21	0.24	104	114	0.22	2.76	13	34.0	21
EZ705B	140	3000	33.8	22.9	1.48	11	41.8	26.5	1.59	0.24	104	87.0	0.33	4.80	15	34.0	21
EZ813B	117	4000	49.5	38.1	1.30	21	62.9	46.6	1.36	0.30	140	130	0.13	1.20	9.1	104	42
EZ813B	239	2000	57.3	21.9	2.62	12	61.6	22.9	2.71	0.30	140	64.9	0.69	5.10	7.4	104	42
EZ815B	117	4000	73.6	56.2	1.31	31	90.8	65.0	1.40	0.30	200	169	0.04	0.72	18	167	54
EZ815B	239	2000	91.0	33.7	2.70	19	100	36.3	2.76	0.30	200	92.4	0.40	3.63	9.1	167	54

## 7.3 Torque/speed curves

Torque/speed curves depend on the nominal speed and/or winding design of the motor and the DC link voltage of the drive controller that is used. The following torque/speed curves apply to the DC link voltage DC 540 V.

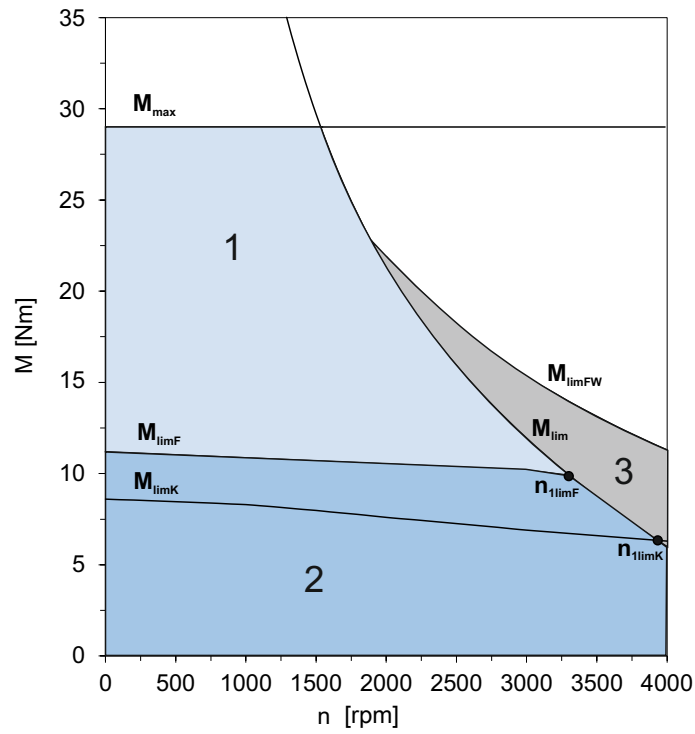
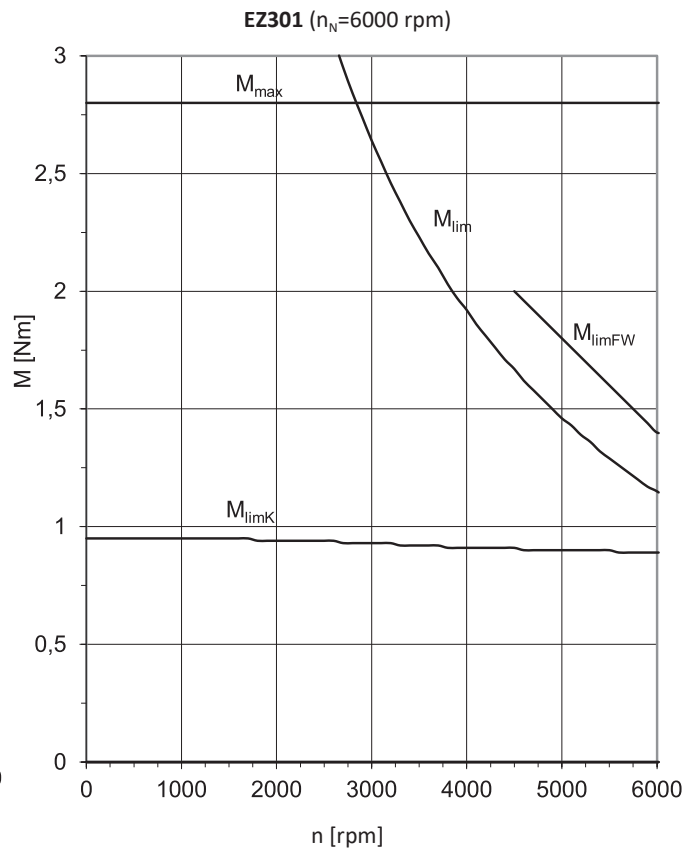
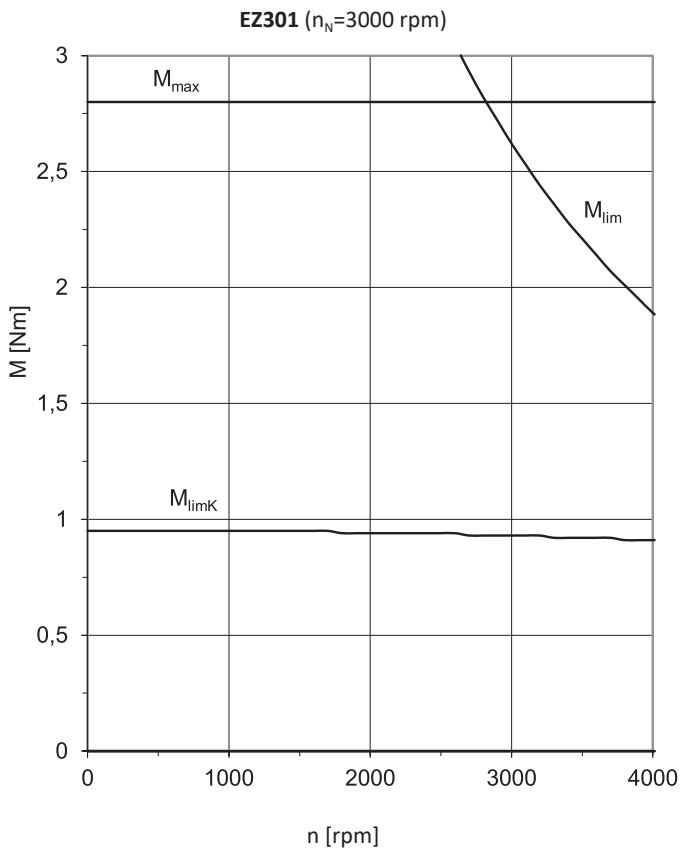
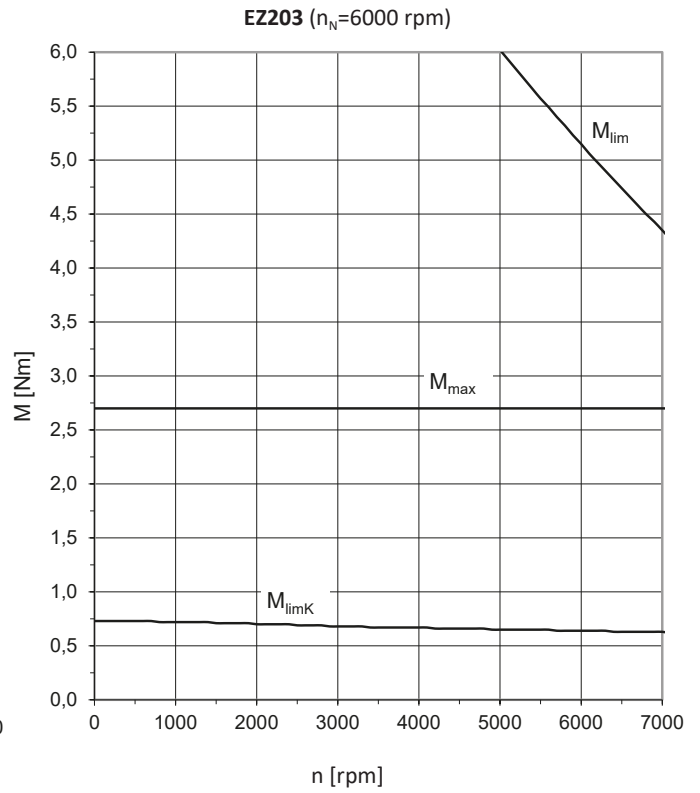
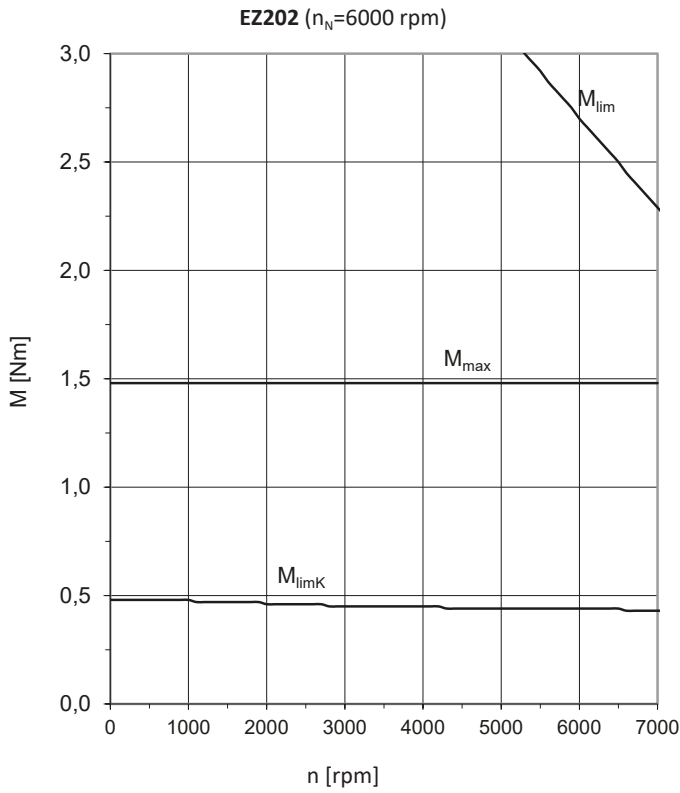
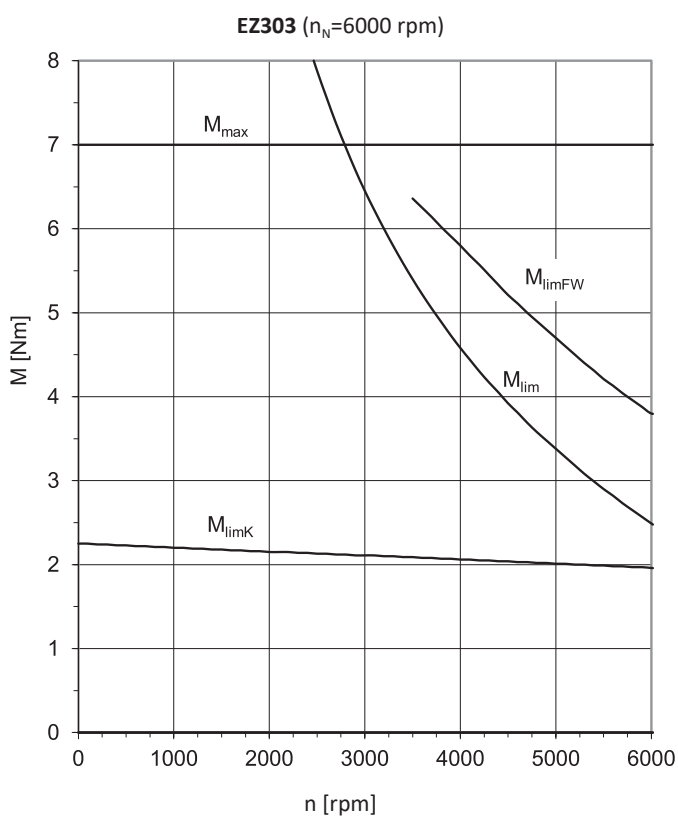
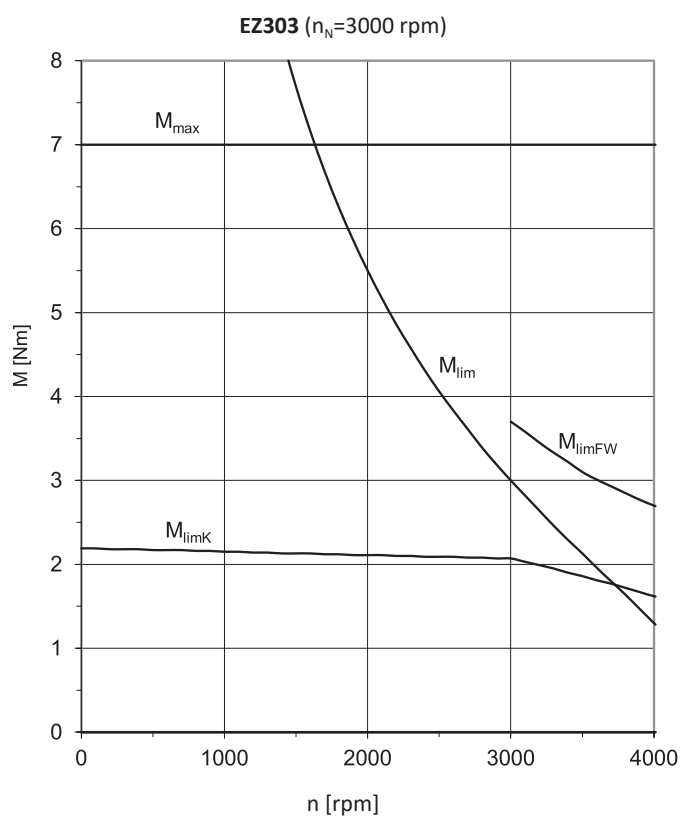
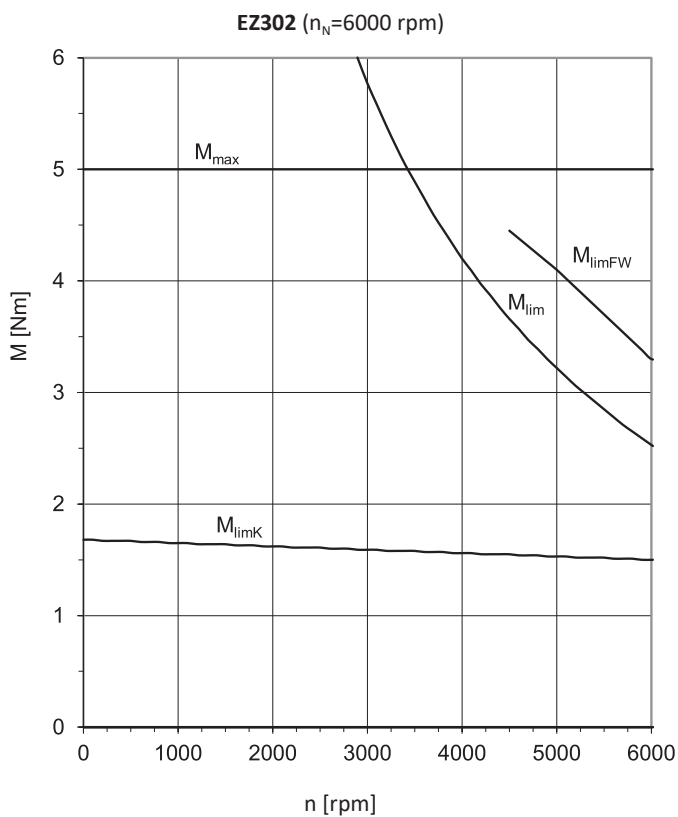
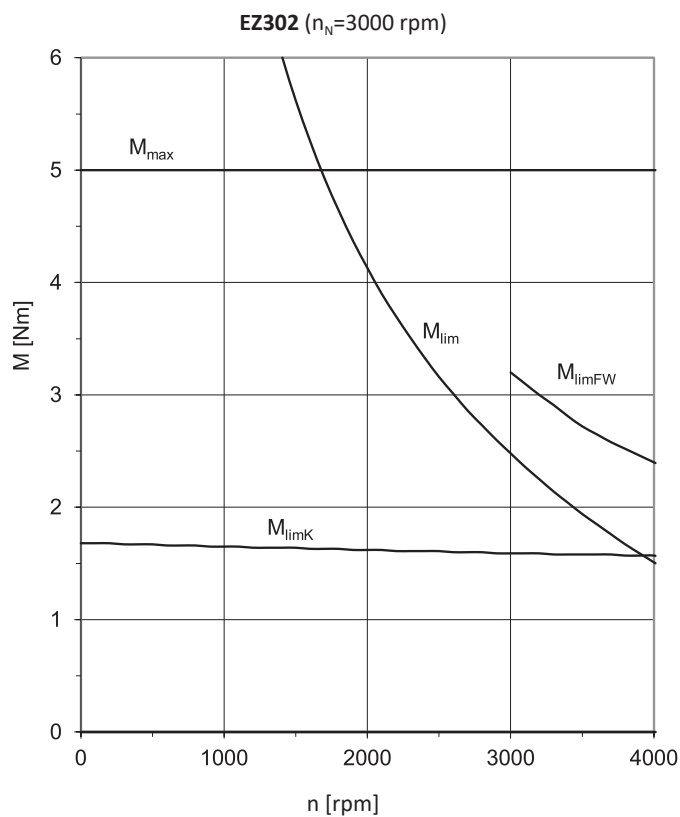

Fig. 1: Explanation of a torque/speed curve

- |   |   |
|---|---|
| <p>1 Torque range for brief operation (<math>ED_{10} &lt; 100\%</math>) with <math>\Delta\vartheta = 100</math> K</p> | <p>2 Torque range for continuous operation with constant load (S1 mode, <math>ED_{10} = 100\%</math>) with <math>\Delta\vartheta = 100</math> K</p> |
| <p>3 Field weakening range (can be used only with operation on STOBBER drive controllers)</p>                         |   |





**EZ401** ( $n_N=3000$  rpm)

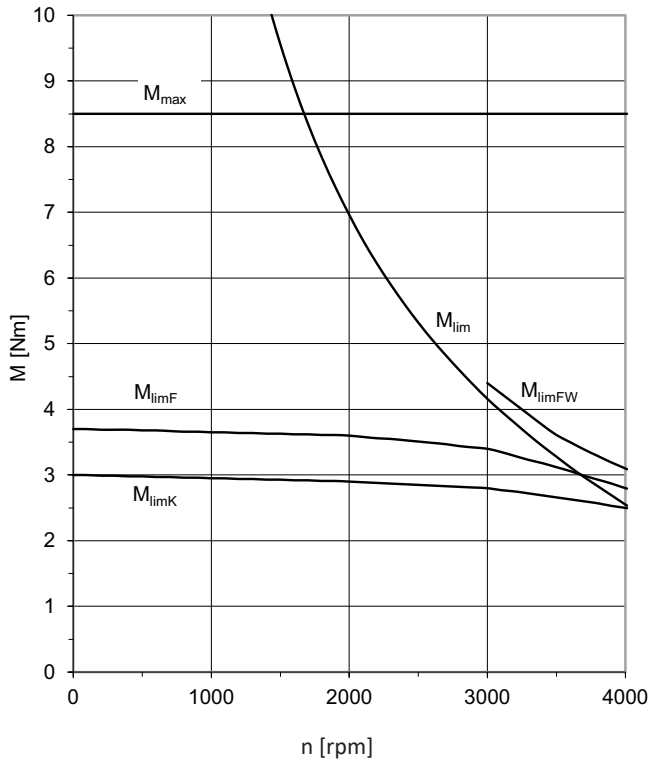

**EZ401** ( $n_N=6000$  rpm)

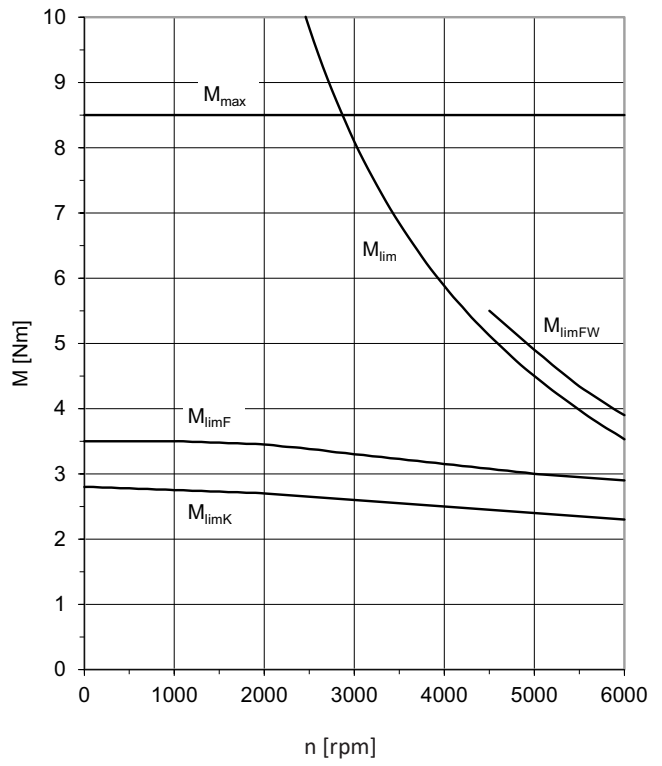

**EZ402** ( $n_N=3000$  rpm)

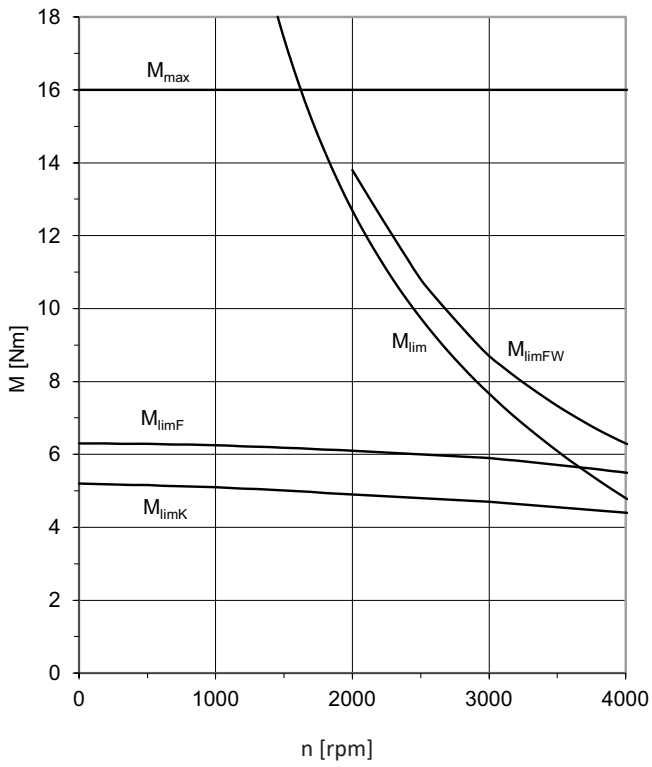

**EZ402** ( $n_N=6000$  rpm)

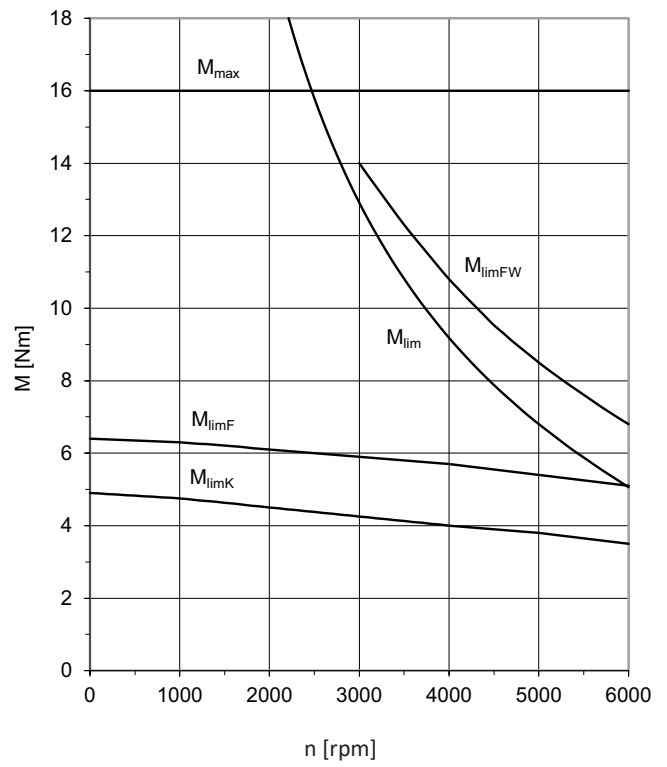

**EZ404** ( $n_N=3000$  rpm)

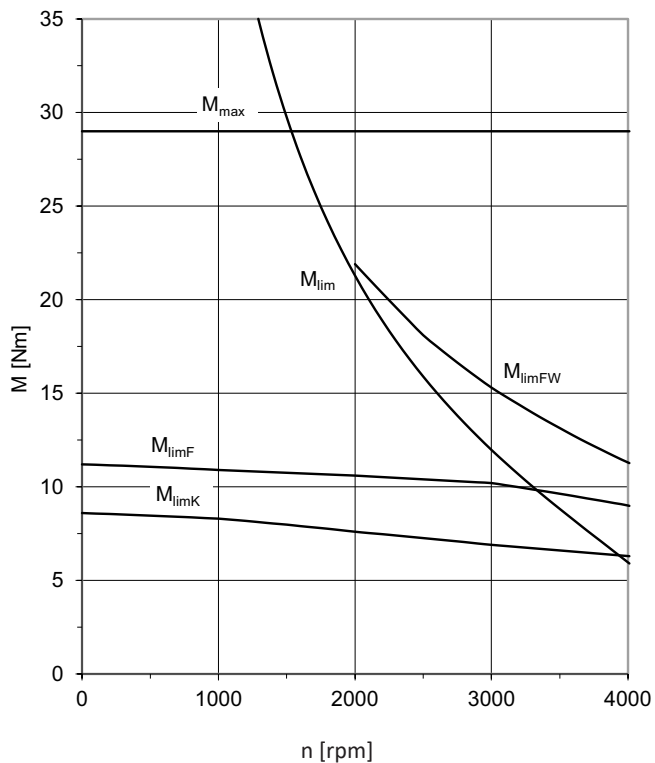

**EZ404** ( $n_N=6000$  rpm)

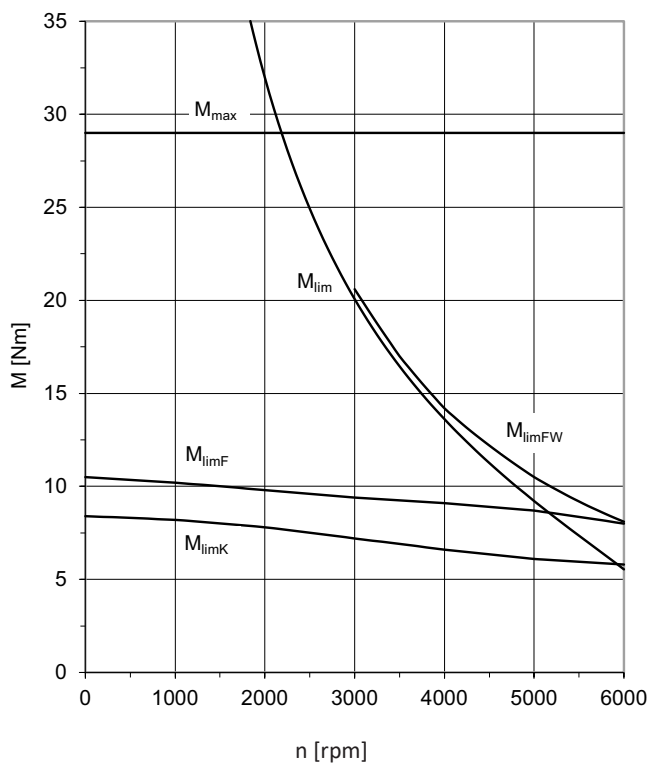

**EZ501** ( $n_N=3000$  rpm)

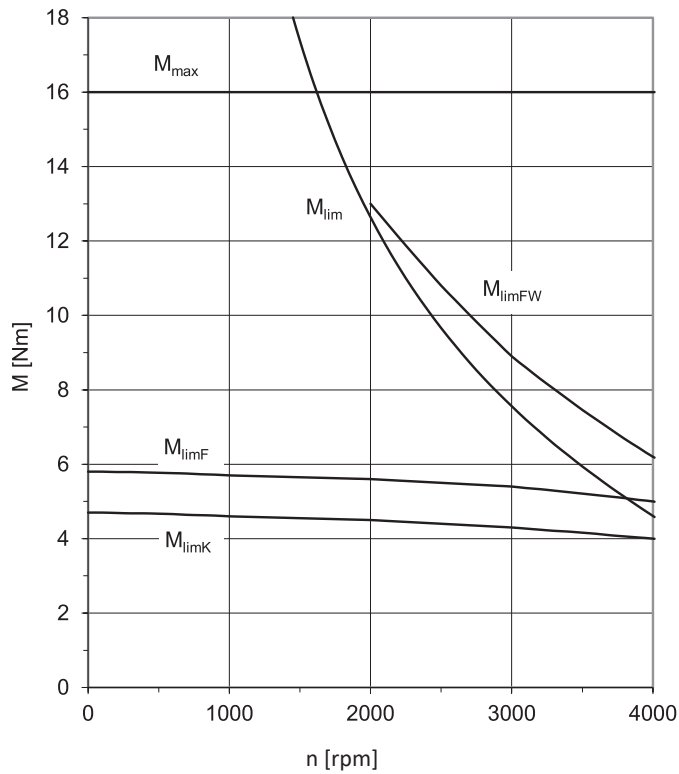

**EZ501** ( $n_N=6000$  rpm)

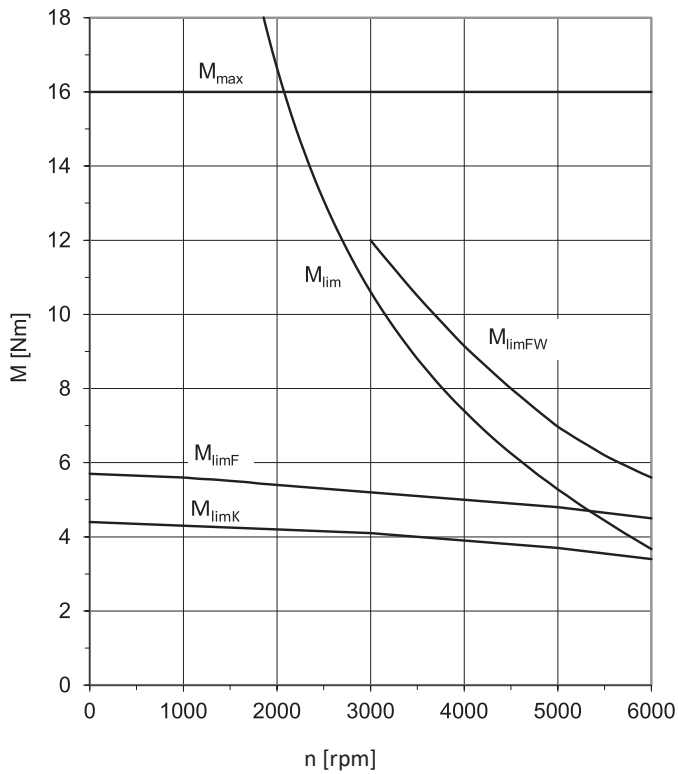

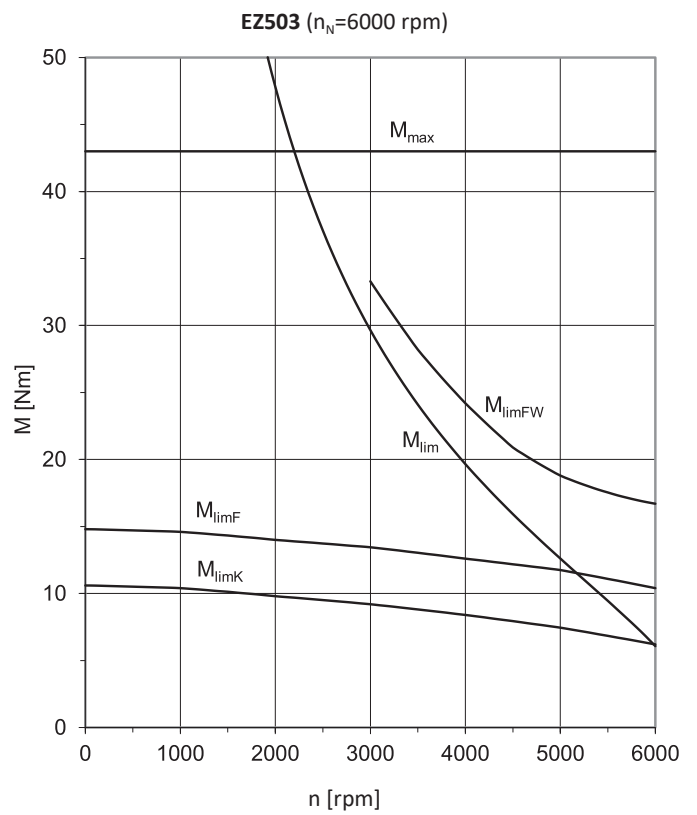
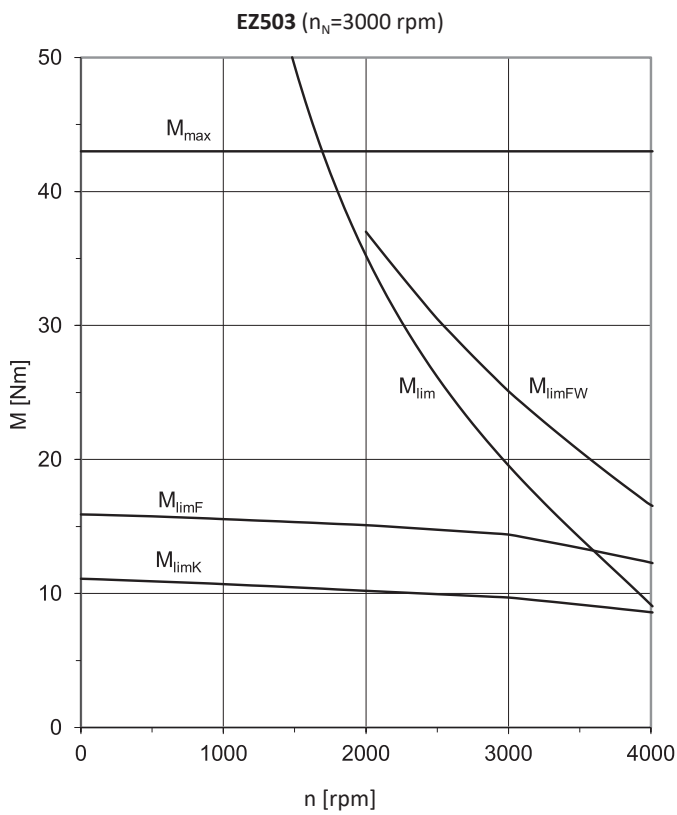
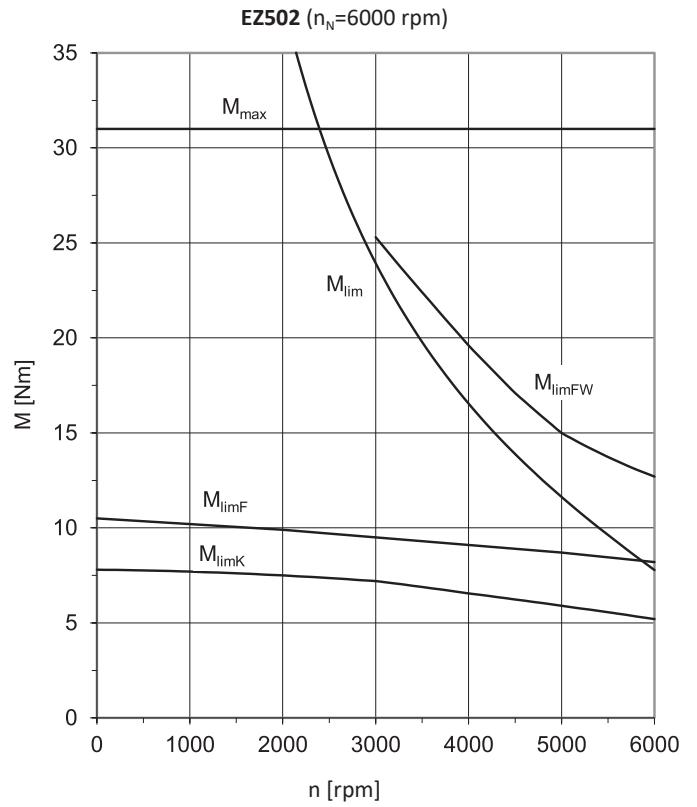
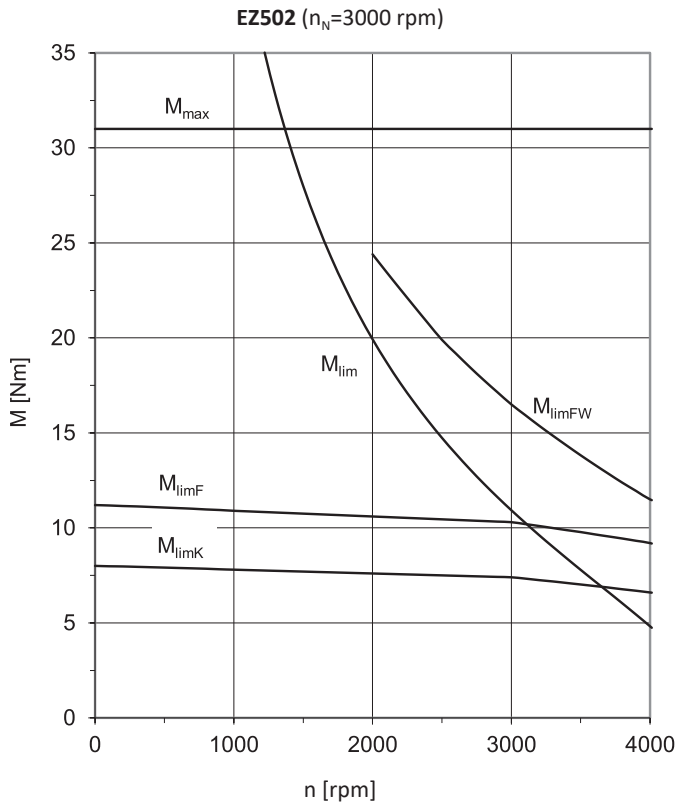

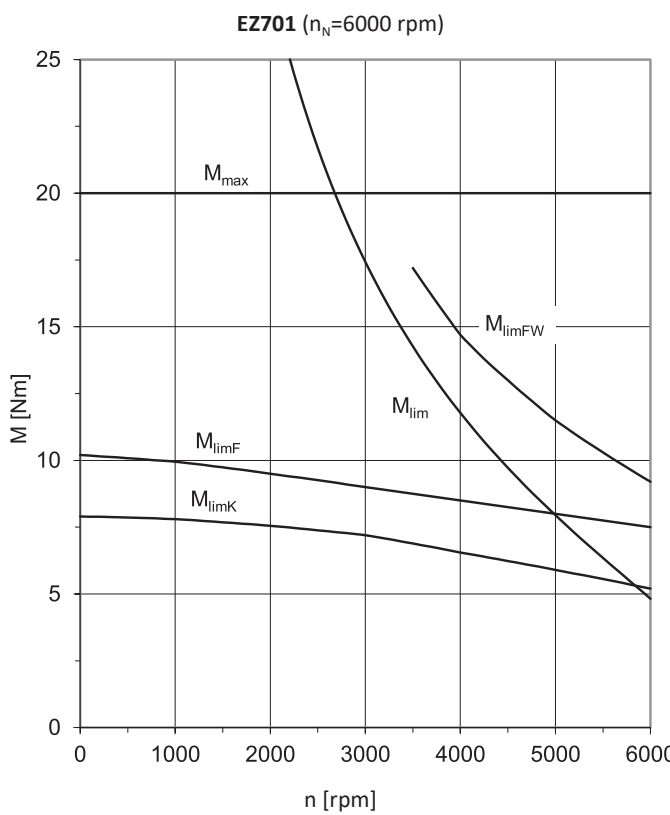
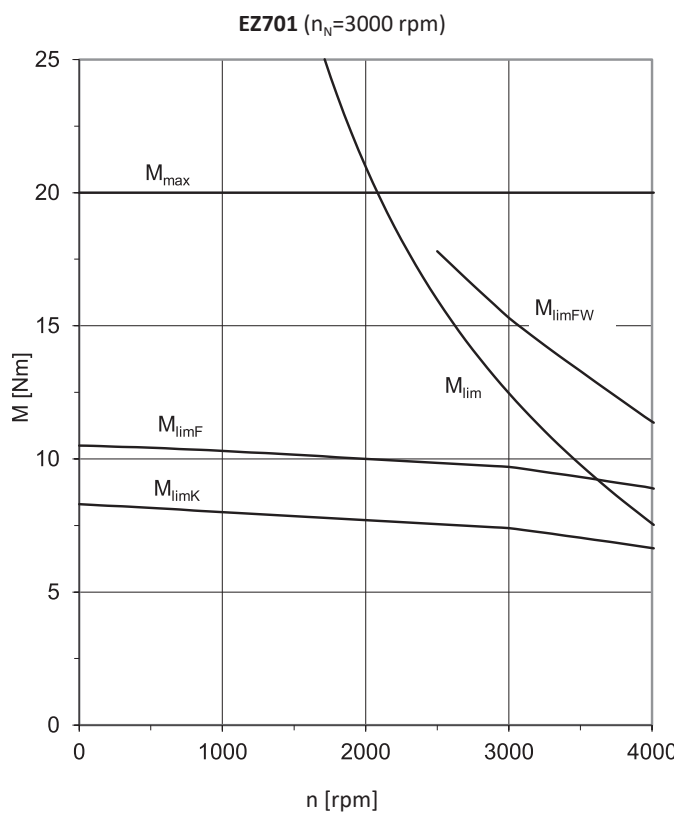
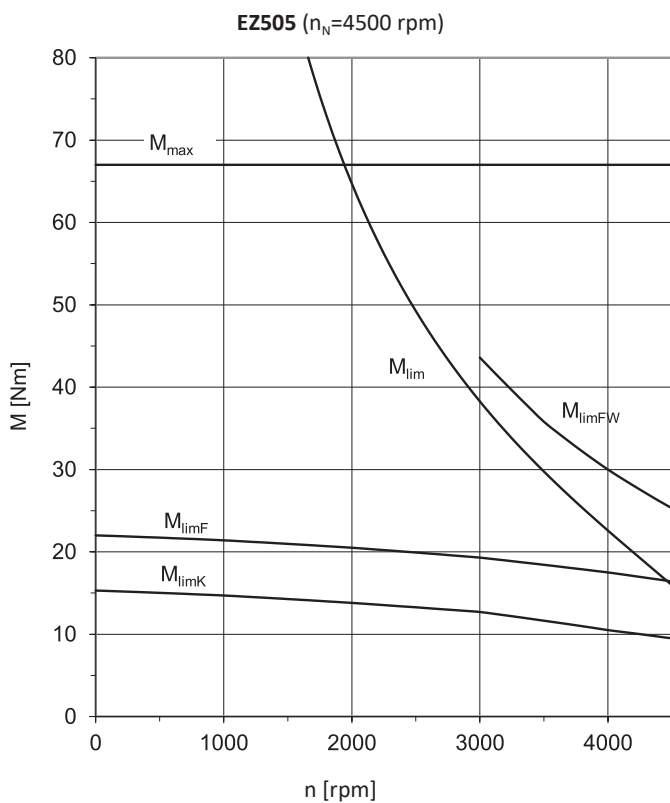
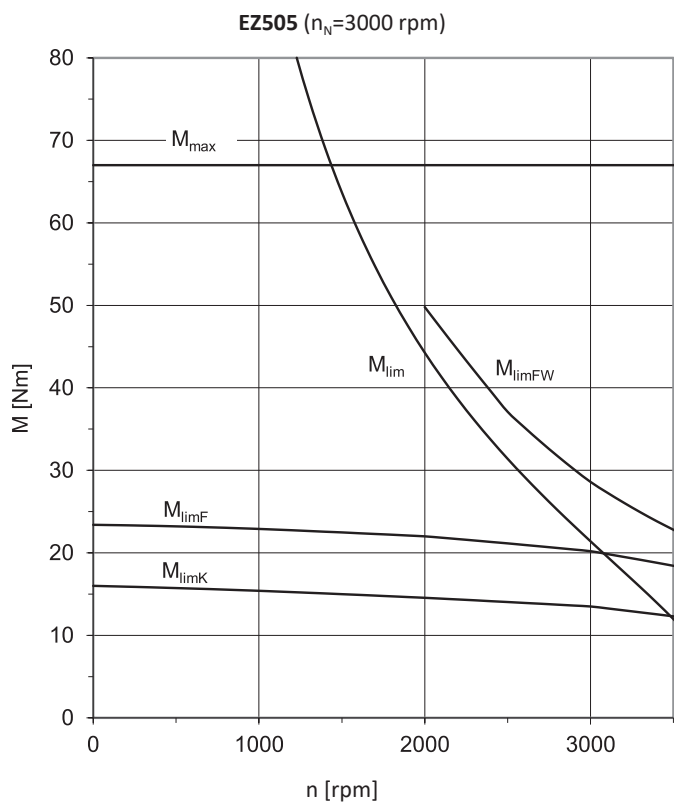

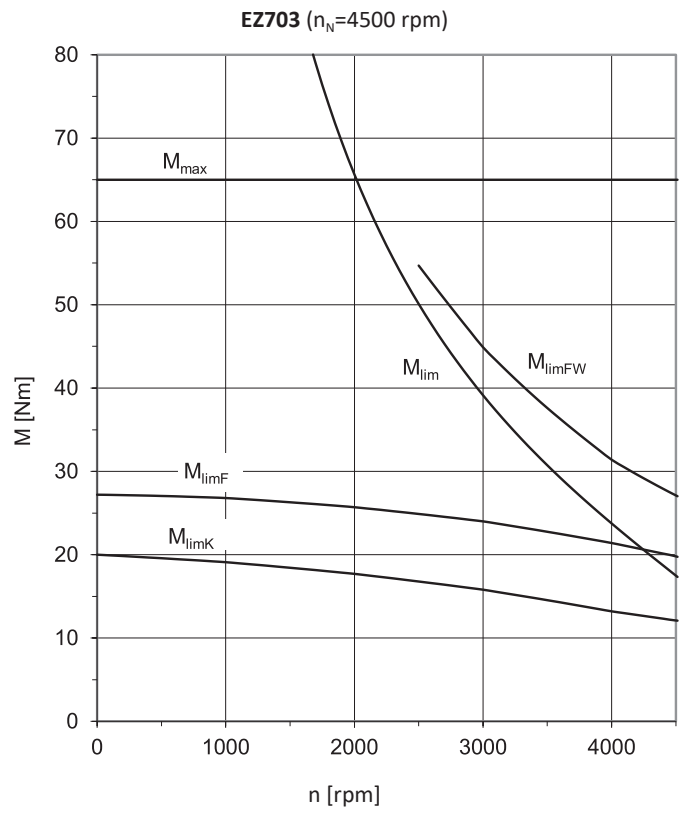
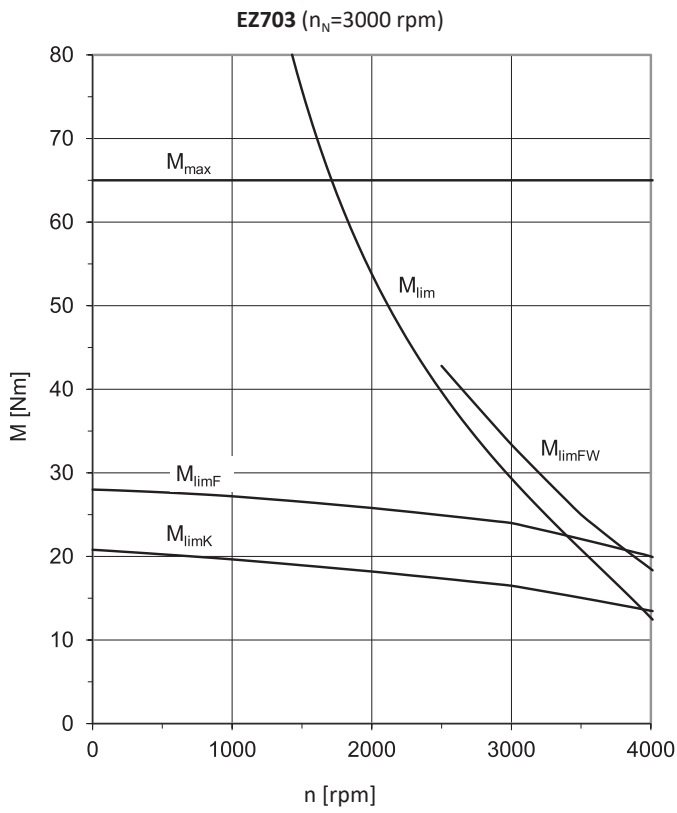
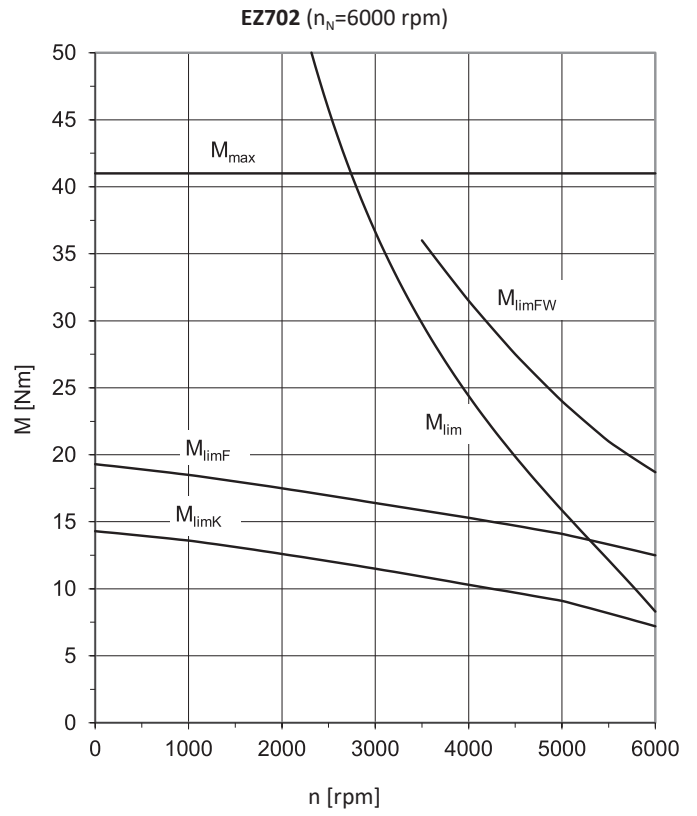
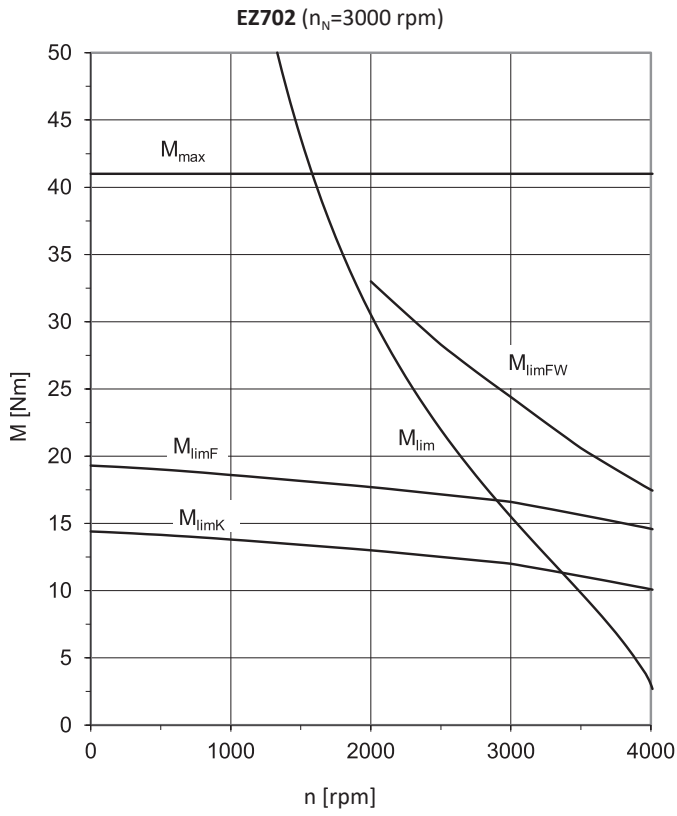

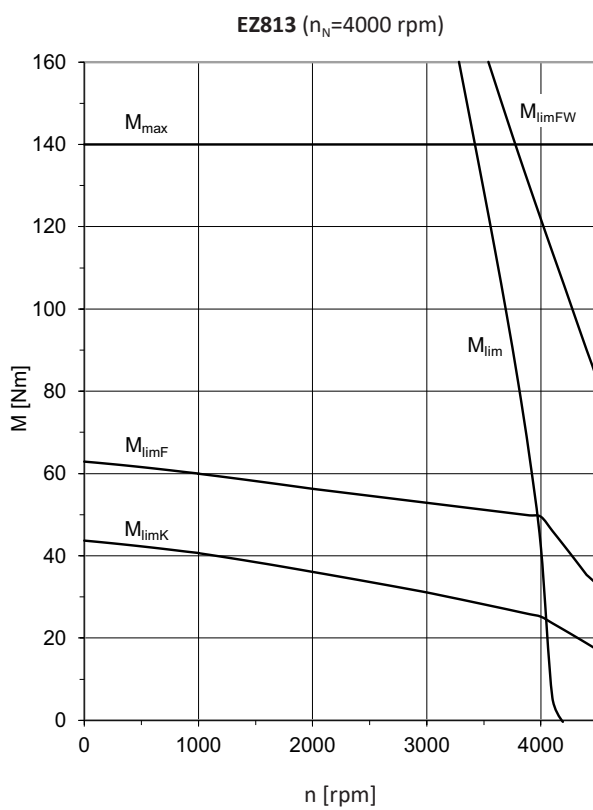
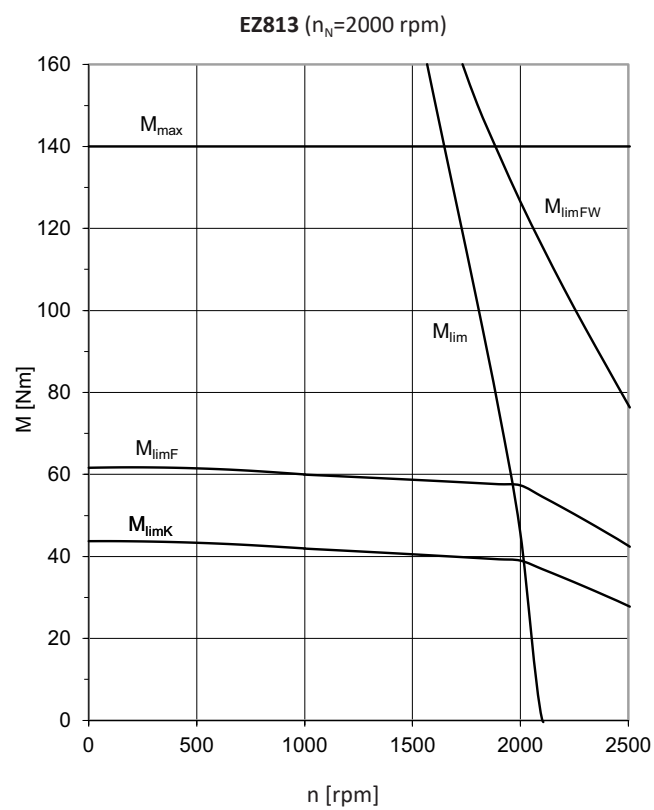
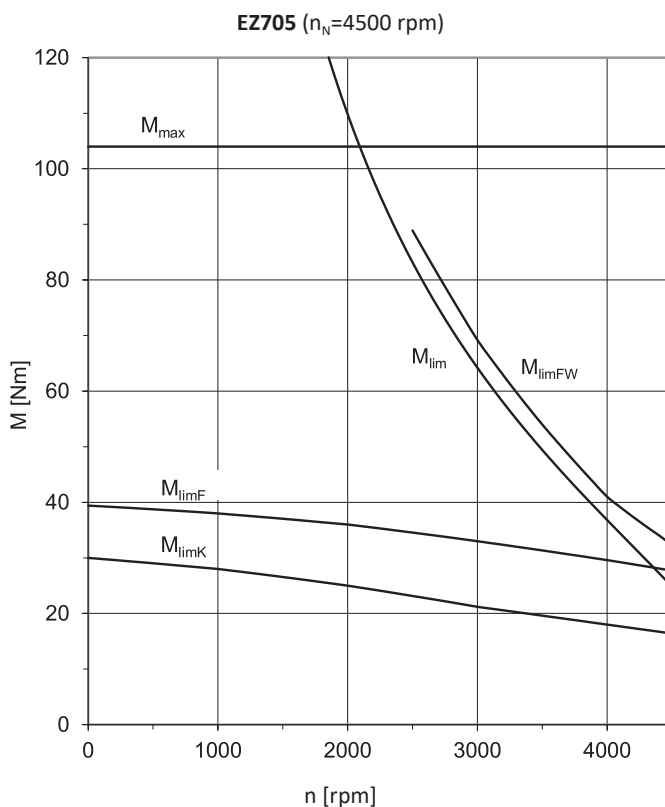
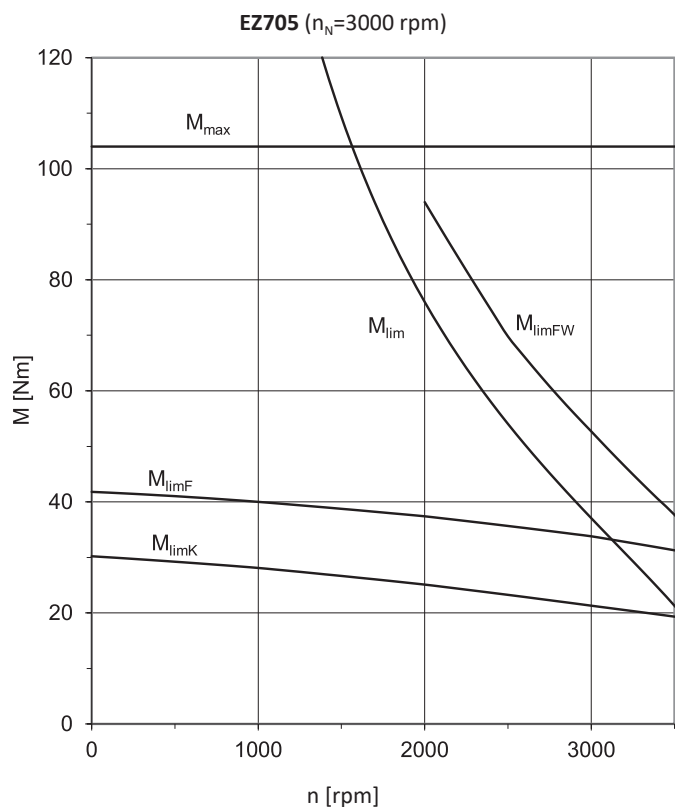

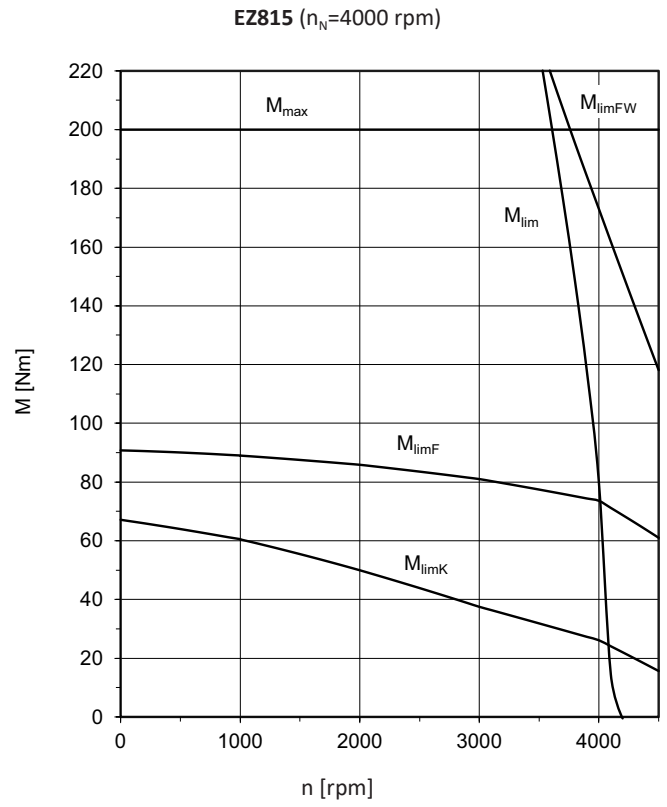
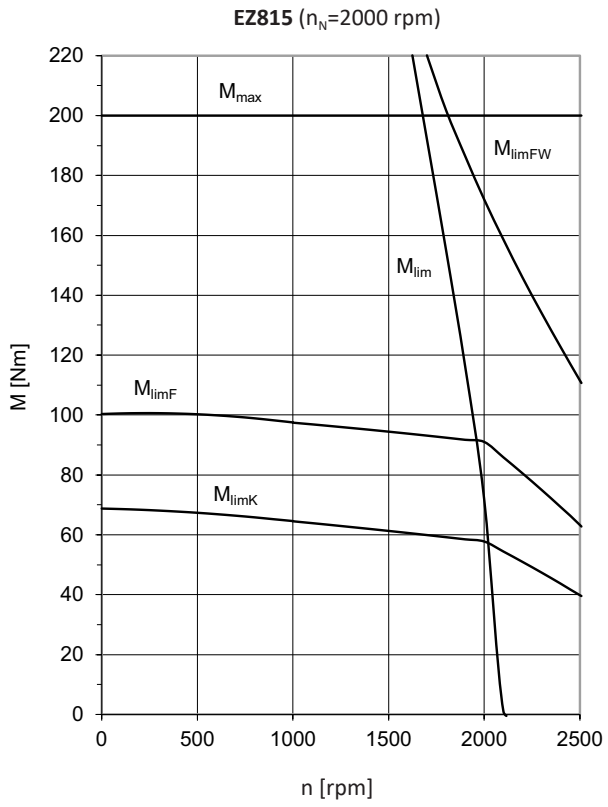

## 7.4 Dimensional drawings

In this chapter, you can find the dimensions of the motors.

Dimensions can exceed the specifications of ISO 2768-mK due to casting tolerances or accumulation of individual tolerances.

We reserve the right to make dimensional changes due to ongoing technical development.

You can download 3D models of our standard drives at <https://configurator.stoeber.de/en-US/>.

### Tolerances

Solid shaft	Tolerance
Shaft $\varnothing$ fit $\leq 50$ mm	DIN 748-1, ISO k6
Shaft $\varnothing$ fit $> 50$ mm	DIN 748-1, ISO m6

### Centering holes in solid shafts in accordance with DIN 332-2, DR shape

Thread size	M4	M5	M6	M8	M10	M12	M16	M20	M24
Thread depth [mm]	10	12.5	16	19	22	28	36	42	50

### 7.4.1 EZ2 – EZ3 motors with convection cooling (One Cable Solution)

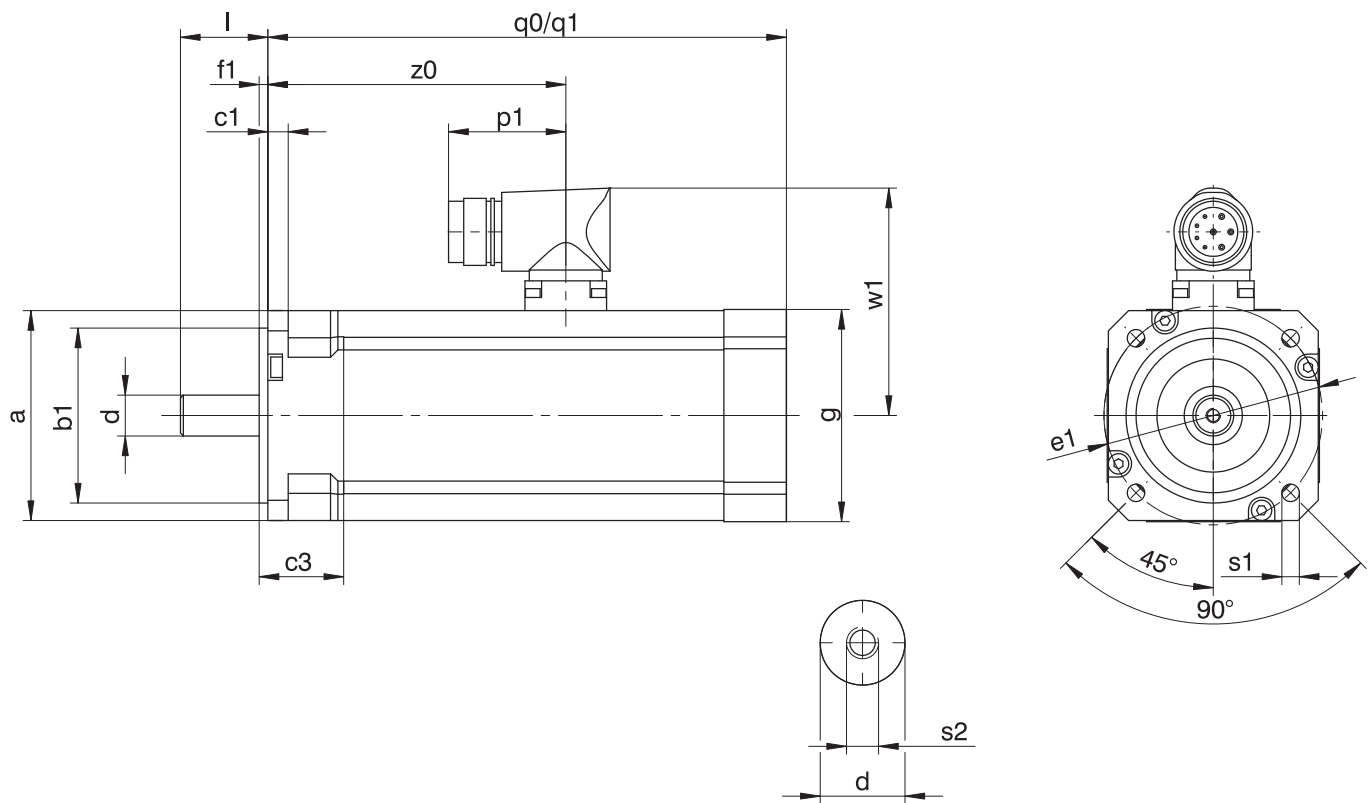

q0 Applies to motors without holding brake

q1 Applies to motors with holding brake

The output shaft is also available as a solid shaft with a feather key. You can find the dimensions at <https://configurator.stoeber.de/en-US/>.

Type	□a	∅b1	c1	c3	∅d	∅e1	f1	□g	l	p1	q0	q1	∅s1	s2	w1	z0
EZ202U	55	40 <sub>f6</sub>	7	7	9 <sub>k6</sub>	63	3.5	55	20	40	148	182	5.8	M4	69.5	93.0
EZ203U	55	40 <sub>f6</sub>	7	7	9 <sub>k6</sub>	63	3.5	55	20	40	166	200	5.8	M4	69.5	111.0
EZ301U	72	60 <sub>f6</sub>	7	26	14 <sub>k6</sub>	75	3.0	72	30	40	116	156	6.0	M5	78.0	80.5
EZ302U	72	60 <sub>f6</sub>	7	26	14 <sub>k6</sub>	75	3.0	72	30	40	138	178	6.0	M5	78.0	102.5
EZ303U	72	60 <sub>f6</sub>	7	26	14 <sub>k6</sub>	75	3.0	72	30	40	160	200	6.0	M5	78.0	124.5

### 7.4.2 EZ2 – EZ3 motors with convection cooling

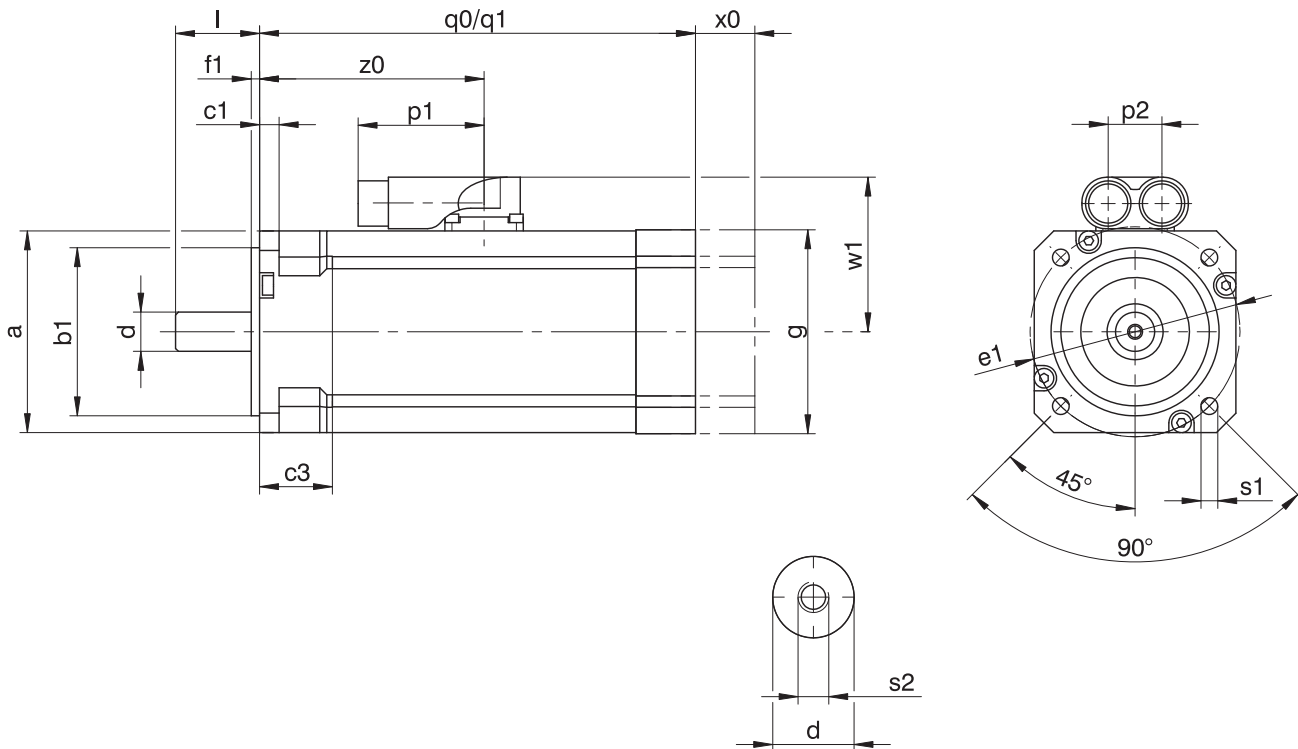

q0 Applies to motors without holding brake

q1 Applies to motors with holding brake

x0 EZ2: Applies only to motors with holding brake and encoders using an optical or inductive measuring method  
 EZ3: Applies to encoders using an optical measuring method

The output shaft is also available as a solid shaft with a feather key. You can find the dimensions at <https://configurator.stoeber.de/en-US/>.

Type	□a	∅b1	c1	c3	∅d	∅e1	f1	□g	l	p1	p2	q0	q1	∅s1	s2	w1	x0	z0
EZ202U	55	40 <sub>j6</sub>	7	7	9 <sub>k6</sub>	63	3.5	55	20	45	19	148	157	5.8	M4	47.0	25	93.0
EZ203U	55	40 <sub>j6</sub>	7	7	9 <sub>k6</sub>	63	3.5	55	20	45	19	166	175	5.8	M4	47.0	25	111.0
EZ301U	72	60 <sub>j6</sub>	7	26	14 <sub>k6</sub>	75	3.0	72	30	45	19	116	156	6.0	M5	55.5	21	80.5
EZ302U	72	60 <sub>j6</sub>	7	26	14 <sub>k6</sub>	75	3.0	72	30	45	19	138	178	6.0	M5	55.5	21	102.5
EZ303U	72	60 <sub>j6</sub>	7	26	14 <sub>k6</sub>	75	3.0	72	30	45	19	160	200	6.0	M5	55.5	21	124.5

### 7.4.3 EZ4 – EZ7 motors with convection cooling (One Cable Solution)

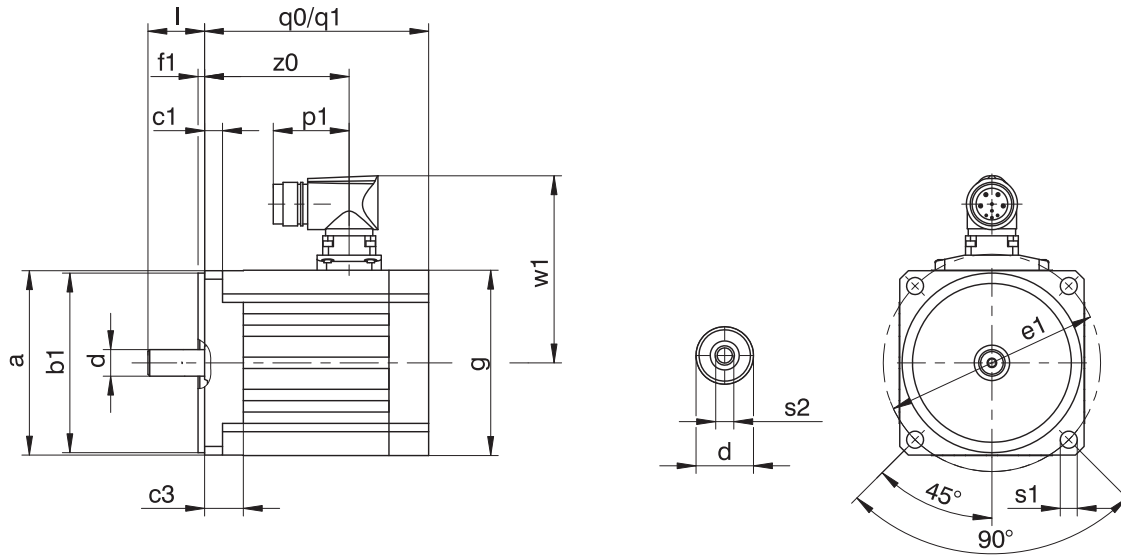

$q0$  Applies to motors without holding brake

$q1$  Applies to motors with holding brake

The output shaft is also available as a solid shaft with a feather key. You can find the dimensions at <https://configurator.stoeber.de/en-US/>.

Type	$\square a$	$\varnothing b1$	$c1$	$c3$	$\varnothing d$	$\varnothing e1$	$f1$	$\square g$	$l$	$p1$	$q0$	$q1$	$\varnothing s1$	$s2$	$w1$	$z0$
EZ401U	98	$95_{j6}$	9.5	20.5	$14_{k6}$	115	3.5	98	30	40	118.5	167.0	9	M5	99	76.5
EZ402U	98	$95_{j6}$	9.5	20.5	$19_{k6}$	115	3.5	98	40	40	143.5	192.0	9	M6	99	101.5
EZ404U	98	$95_{j6}$	9.5	20.5	$19_{k6}$	115	3.5	98	40	40	193.5	242.0	9	M6	99	151.5
EZ501U	115	$110_{j6}$	10.0	16.0	$19_{k6}$	130	3.5	115	40	40	109.0	163.5	9	M6	110	74.5
EZ502U	115	$110_{j6}$	10.0	16.0	$19_{k6}$	130	3.5	115	40	40	134.0	188.5	9	M6	110	99.5
EZ503U	115	$110_{j6}$	10.0	16.0	$24_{k6}$	130	3.5	115	50	40	159.0	213.5	9	M8	110	124.5
EZ505U	115	$110_{j6}$	10.0	16.0	$24_{k6}$	130	3.5	115	50	40	209.0	263.5	9	M8	110	174.5
EZ701U	145	$130_{j6}$	10.0	19.0	$24_{k6}$	165	3.5	145	50	40	121.0	180.0	11	M8	125	83.0
EZ702U	145	$130_{j6}$	10.0	19.0	$24_{k6}$	165	3.5	145	50	40	146.0	205.0	11	M8	125	108.0
EZ703U	145	$130_{j6}$	10.0	19.0	$24_{k6}$	165	3.5	145	50	40	171.0	230.0	11	M8	125	133.0
EZ705U	145	$130_{j6}$	10.0	19.0	$32_{k6}$	165	3.5	145	58	40	226.0	285.0	11	M12	125	184.0

### 7.4.4 EZ4 – EZ8 motors with convection cooling

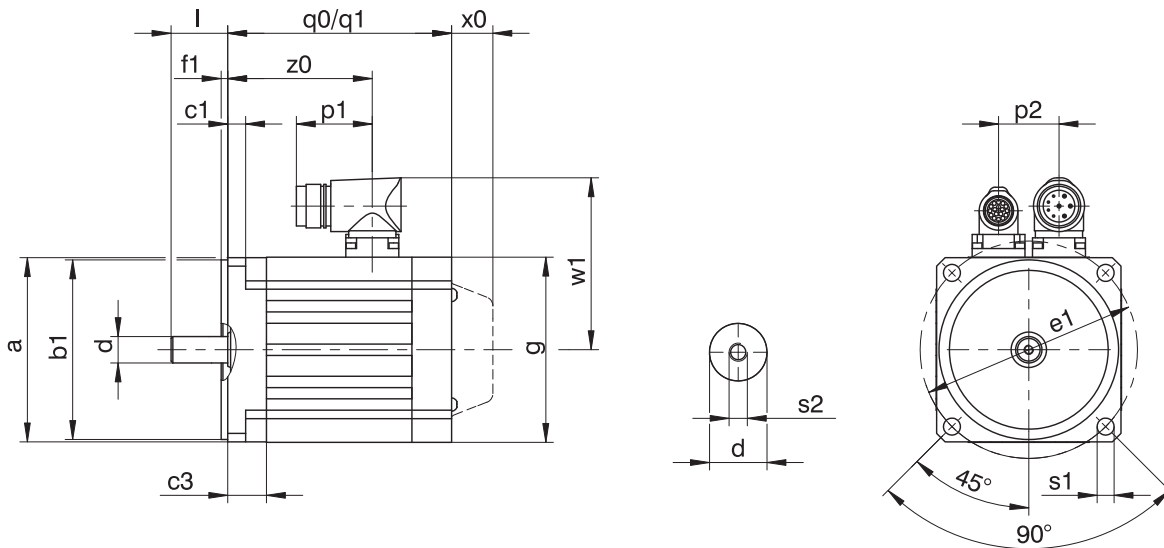

q0 Applies to motors without holding brake

q1 Applies to motors with holding brake

x0 Applies to encoders using an optical measuring method

The output shaft is also available as a solid shaft with a feather key. You can find the dimensions at <https://configurator.stoeber.de/en-US/>.

Type	□a	Øb1	c1	c3	Ød	Øe1	f1	□g	l	p1	p2	q0	q1	Øs1	s2	w1	x0	z0
EZ401U	98	95 <sub>6</sub>	9.5	20.5	14 <sub>6</sub>	115	3.5	98	30	40	32	118.5	167.0	9.0	M5	91.0	22	76.5
EZ402U	98	95 <sub>6</sub>	9.5	20.5	19 <sub>6</sub>	115	3.5	98	40	40	32	143.5	192.0	9.0	M6	91.0	22	101.5
EZ404U	98	95 <sub>6</sub>	9.5	20.5	19 <sub>6</sub>	115	3.5	98	40	40	32	193.5	242.0	9.0	M6	91.0	22	151.5
EZ501U	115	110 <sub>6</sub>	10.0	16.0	19 <sub>6</sub>	130	3.5	115	40	40	36	109.0	163.5	9.0	M6	100.0	22	74.5
EZ502U	115	110 <sub>6</sub>	10.0	16.0	19 <sub>6</sub>	130	3.5	115	40	40	36	134.0	188.5	9.0	M6	100.0	22	99.5
EZ503U	115	110 <sub>6</sub>	10.0	16.0	24 <sub>6</sub>	130	3.5	115	50	40	36	159.0	213.5	9.0	M8	100.0	22	124.5
EZ505U	115	110 <sub>6</sub>	10.0	16.0	24 <sub>6</sub>	130	3.5	115	50	40	36	209.0	263.5	9.0	M8	100.0	22	174.5
EZ701U	145	130 <sub>6</sub>	10.0	19.0	24 <sub>6</sub>	165	3.5	145	50	40	42	121.0	180.0	11.0	M8	115.0	22	83.0
EZ702U	145	130 <sub>6</sub>	10.0	19.0	24 <sub>6</sub>	165	3.5	145	50	40	42	146.0	205.0	11.0	M8	115.0	22	108.0
EZ703U	145	130 <sub>6</sub>	10.0	19.0	24 <sub>6</sub>	165	3.5	145	50	40	42	171.0	230.0	11.0	M8	115.0	22	133.0
EZ705U	145	130 <sub>6</sub>	10.0	19.0	32 <sub>6</sub>	165	3.5	145	58	71	42	226.0	285.0	11.0	M12	134.0	22	184.0
EZ813U	190	180 <sub>6</sub>	15.0	25.0	38 <sub>6</sub>	215	3.5	190	80	71	60	263.0	340.0	13.5	M12	156.5	22	209.0
EZ815U	190	180 <sub>6</sub>	15.0	25.0	38 <sub>6</sub>	215	3.5	190	80	71	60	345.0	422.0	13.5	M12	156.5	22	291.0

### 7.4.5 EZ4 – EZ7 motors with forced ventilation (One Cable Solution)

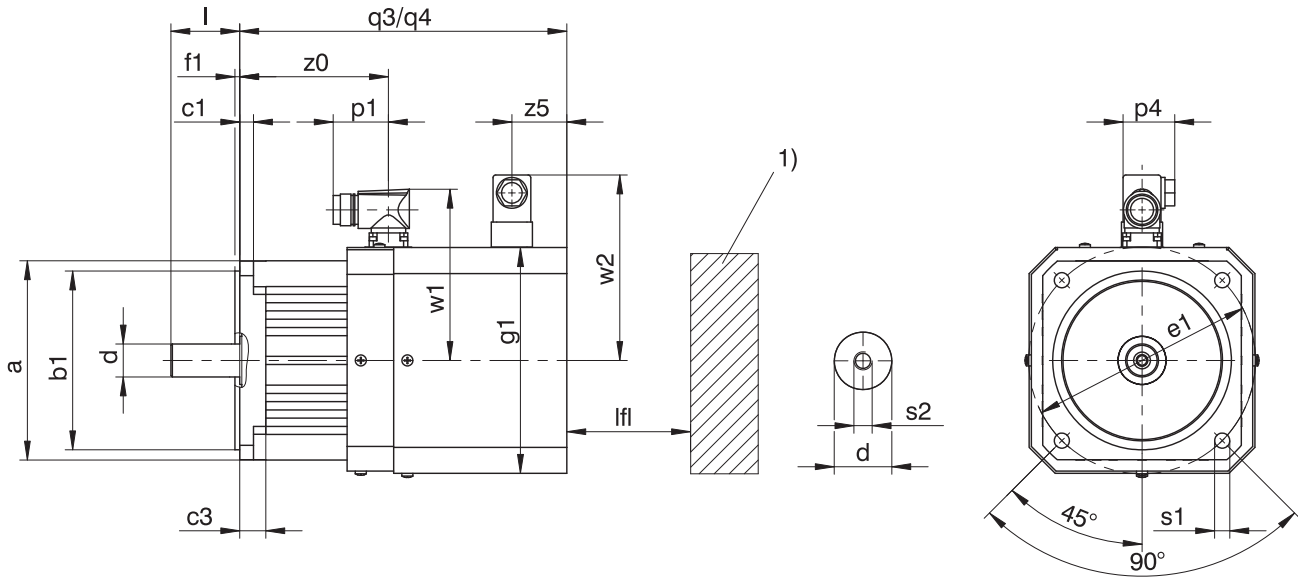

q3 Applies to motors without holding brake

q4 Applies to motors with holding brake

1) Machine wall

The output shaft is also available as a solid shaft with a feather key. You can find the dimensions at <https://configurator.stoeber.de/en-US/>.

Type	□a	∅b1	c1	c3	∅d	∅e1	f1	□g1	l	lfl <sub>min</sub>	p1	p4	q3	q4	∅s1	s2	w1	w2	z0	z5
EZ401B	98	95 <sub>js</sub>	9.5	20.5	14 <sub>kg</sub>	115	3.5	118	30	20	40	37.5	175	224	9.0	M5	99	111	76.5	25
EZ402B	98	95 <sub>js</sub>	9.5	20.5	19 <sub>kg</sub>	115	3.5	118	40	20	40	37.5	200	249	9.0	M6	99	111	101.5	25
EZ404B	98	95 <sub>js</sub>	9.5	20.5	19 <sub>kg</sub>	115	3.5	118	40	20	40	37.5	250	299	9.0	M6	99	111	151.5	25
EZ501B	115	110 <sub>js</sub>	10.0	16.0	19 <sub>kg</sub>	130	3.5	135	40	20	40	37.5	179	234	9.0	M6	110	120	74.5	25
EZ502B	115	110 <sub>js</sub>	10.0	16.0	19 <sub>kg</sub>	130	3.5	135	40	20	40	37.5	204	259	9.0	M6	110	120	99.5	25
EZ503B	115	110 <sub>js</sub>	10.0	16.0	24 <sub>kg</sub>	130	3.5	135	50	20	40	37.5	229	284	9.0	M8	110	120	124.5	25
EZ505B	115	110 <sub>js</sub>	10.0	16.0	24 <sub>kg</sub>	130	3.5	135	50	20	40	37.5	279	334	9.0	M8	110	120	174.5	25
EZ701B	145	130 <sub>js</sub>	10.0	19.0	24 <sub>kg</sub>	165	3.5	165	50	30	40	37.5	213	272	11.0	M8	125	134	83.0	40
EZ702B	145	130 <sub>js</sub>	10.0	19.0	24 <sub>kg</sub>	165	3.5	165	50	30	40	37.5	238	297	11.0	M8	125	134	108.0	40
EZ703B	145	130 <sub>js</sub>	10.0	19.0	24 <sub>kg</sub>	165	3.5	165	50	30	40	37.5	263	322	11.0	M8	125	134	133.0	40

### 7.4.6 EZ4 – EZ8 motors with forced ventilation

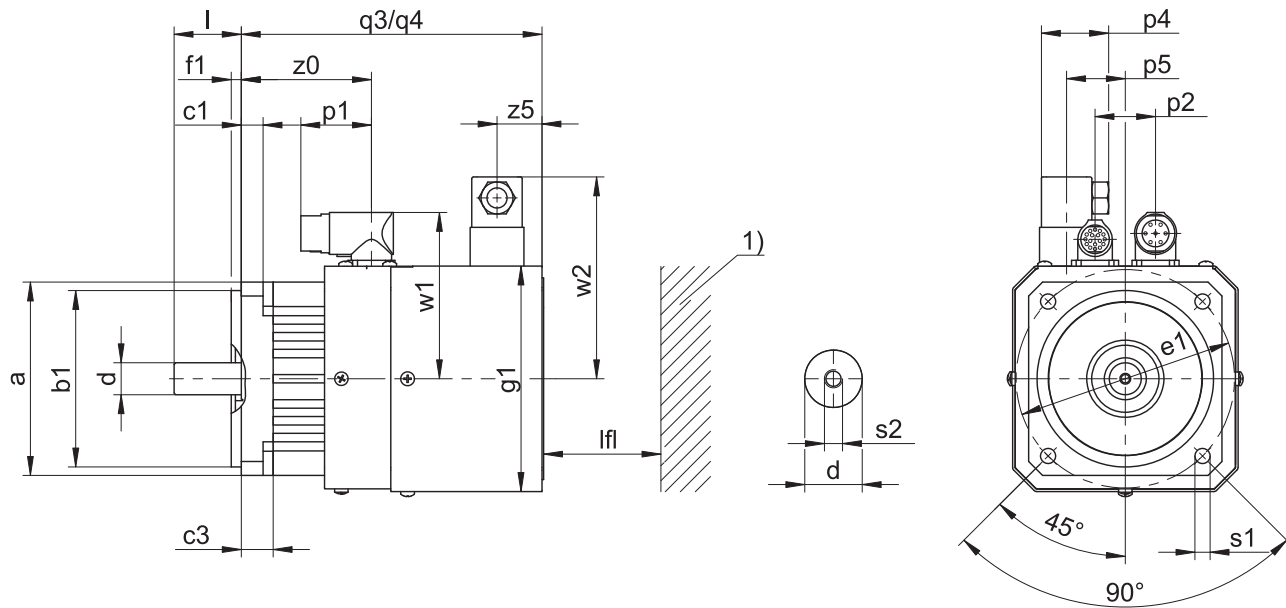

q3 Applies to motors without holding brake

q4 Applies to motors with holding brake

1) Machine wall

The output shaft is also available as a solid shaft with a feather key. You can find the dimensions at <https://configurator.stoeber.de/en-US/>.

Type	□a	∅b1	c1	c3	∅d	∅e1	f1	□g1	l	lfl <sub>min</sub>	p1	p2	p4	p5	q3	q4	∅s1	s2	w1	w2	z0	z5
EZ401B	98	95 <sub>β</sub>	9.5	20.5	14 <sub>κ6</sub>	115	3.5	118	30	20	40	32	37.5	0	175	224	9.0	M5	91.0	111	76.5	25
EZ402B	98	95 <sub>β</sub>	9.5	20.5	19 <sub>κ6</sub>	115	3.5	118	40	20	40	32	37.5	0	200	249	9.0	M6	91.0	111	101.5	25
EZ404B	98	95 <sub>β</sub>	9.5	20.5	19 <sub>κ6</sub>	115	3.5	118	40	20	40	32	37.5	0	250	299	9.0	M6	91.0	111	151.5	25
EZ501B	115	110 <sub>β</sub>	10.0	16.0	19 <sub>κ6</sub>	130	3.5	135	40	20	40	36	37.5	0	179	234	9.0	M6	100.0	120	74.5	25
EZ502B	115	110 <sub>β</sub>	10.0	16.0	19 <sub>κ6</sub>	130	3.5	135	40	20	40	36	37.5	0	204	259	9.0	M6	100.0	120	99.5	25
EZ503B	115	110 <sub>β</sub>	10.0	16.0	24 <sub>κ6</sub>	130	3.5	135	50	20	40	36	37.5	0	229	284	9.0	M8	100.0	120	124.5	25
EZ505B	115	110 <sub>β</sub>	10.0	16.0	24 <sub>κ6</sub>	130	3.5	135	50	20	40	36	37.5	0	279	334	9.0	M8	100.0	120	174.5	25
EZ701B	145	130 <sub>β</sub>	10.0	19.0	24 <sub>κ6</sub>	165	3.5	165	50	30	40	42	37.5	0	213	272	11.0	M8	115.0	134	83.0	40
EZ702B	145	130 <sub>β</sub>	10.0	19.0	24 <sub>κ6</sub>	165	3.5	165	50	30	40	42	37.5	0	238	297	11.0	M8	115.0	134	108.0	40
EZ703B	145	130 <sub>β</sub>	10.0	19.0	24 <sub>κ6</sub>	165	3.5	165	50	30	40	42	37.5	0	263	322	11.0	M8	115.0	134	133.0	40
EZ705B	145	130 <sub>β</sub>	10.0	19.0	32 <sub>κ6</sub>	165	3.5	165	58	30	71	42	37.5	0	318	377	11.0	M12	134.0	134	184.0	40
EZ813B	190	180 <sub>β</sub>	15.0	25.0	38 <sub>κ6</sub>	215	3.5	215	80	30	71	60	37.5	62	363	440	13.5	M12	156.5	160	209.0	40
EZ815B	190	180 <sub>β</sub>	15.0	25.0	38 <sub>κ6</sub>	215	3.5	215	80	30	71	60	37.5	62	445	522	13.5	M12	156.5	160	291.0	40

## 7.5 Type designation

### Example code

EZ	4	0	1	U	D	BB	S7	O	096
----	---	---	---	---	---	----	----	---	-----

### Explanation

Code	Designation	Design
EZ	Type	Synchronous servo motor
4	Size	4 (example)
0	Generation	0
1	Length	1 (example)
U	Cooling <sup>2</sup>	Convection cooling
B		Forced ventilation
D	Design	Dynamic
BB	Drive controller	SI6 (example)
S7	Encoder	EnDat 3 EQI 1131 Safety (example)
O	Brake	Without holding brake
P		Permanent magnet holding brake
096	Voltage constant $K_{EM}$	96 V/1000 rpm (example)

### Notes

- In the chapter [\[▶ 7.6.4\]](#), you can find information about available encoders.
- In the chapter [\[▶ 7.6.4.6\]](#), you can find information about connecting synchronous servo motors to other drive controllers from STÖBER.

## 7.5.1 Nameplate

The nameplate of an EZ401 synchronous servo motor is explained as an example in the figure below.

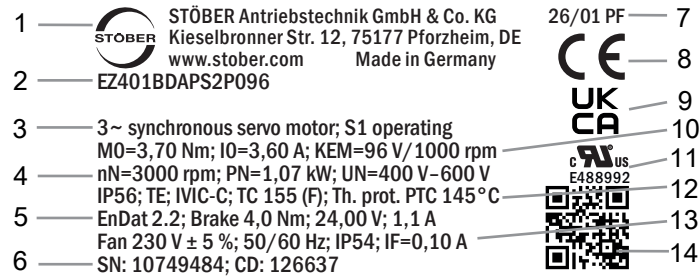

Line	Value	Description
1	STÖBER Antriebstechnik GmbH & Co. KG	Logo and address of the manufacturer
2	EZ401BDAPS2P096	Type designation according to the manufacturer
3	3~ synchronous servo motor S1 operating	Motor type: Three-phase synchronous servo motor Operating mode
4	nN=3000 rpm PN=1.07 kW UN=400 V - 600 V	Nominal speed Nominal power Nominal voltage
5	EnDat 2.2 Brake 4.0 Nm 24.00 V 1.1 A	Encoder interface Holding brake (optional) Static braking torque at 100 °C Nominal voltage (DC) of the holding brake Nominal current of the holding brake at 20 °C
6	SN: 10087606 CD: 126637	Serial number of the motor Customer-specific data
7	26/01 PF	Date of manufacture (year/calendar week) Place of manufacture (abbreviation)
8	CE	CE mark
9	UKCA	UKCA mark
10	M0=3.70 Nm I0=3.60 A KEM=96 V/1000 rpm	Stall torque Stall current Voltage constant
11	cURus E488992	cURus test symbol, registered under UL number E488992
12	IP56 TE IVIC-C TC 155 (F) Th. prot. PTC 145 °C	Protection class Protection class in accordance with UL1004 Impulse voltage insulation class Thermal class Type of temperature sensor
13	Fan 230 V ± 5%; 50/60 Hz IP54 IF = 0.10 A	Forced ventilation unit (option) Nominal voltage of the forced ventilation unit Protection class of the forced ventilation unit Nominal current of the forced ventilation unit
14	QR code	Link to product information

## 7.6 Product description

### 7.6.1 General features

Feature	Description
Design	IM B5, IM V1, IM V3 in accordance with EN 60034-7
Protection class	IP56 / IP66 (option)
Thermal class	155 (F) in accordance with EN 60034-1 (155 °C, heating $\Delta\theta = 100$ K)
Surface	Matte black as per RAL 9005
Cooling	IC 410 convection cooling (IC 416 convection cooling with forced ventilation units, optional)
Bearing	Rolling bearing with lifetime lubrication and non-contact sealing
Sealing	Radial shaft seal rings made of FKM (A side)
Shaft	Solid shaft without feather key, diameter quality k6 Solid shaft with feather key, diameter quality k6
Radial runout	Normal tolerance class in accordance with IEC 60072-1
Concentricity	Normal tolerance class in accordance with IEC 60072-1
Axial runout	Normal tolerance class in accordance with IEC 60072-1
Vibration intensity	A in accordance with EN 60034-14
Noise level	Limit values in accordance with EN 60034-9

### 7.6.2 Electrical features

General electrical features of the motor are described in this chapter. You can find more details in Chapter [\[ 7.2 \]](#).

Feature	Description
DC link voltage	DC 540 V (max. 750 V) on STOBBER drive controllers
Winding	Three-phase
Circuit	Star, center not led through
Protection class	I (protective grounding) in accordance with EN 61140
Impulse voltage insulation class (IVIC)	C in accordance with DIN EN 60034-18-41 (inverter connection voltage 0 – 480 V $\pm$ 10%)
Number of pole pairs	2 (EZ2) 5 (EZ3) 7 (EZ4/EZ5/EZ7) 4 (EZ81)

### 7.6.3 Ambient conditions

Standard ambient conditions for transport, storage and operation of the motor are described in this chapter. Information about differing ambient conditions can be found in the chapter [\[ 7.7.3 \]](#).

Feature	Description
Surrounding temperature for transport/storage	–30 °C to +85 °C
Surrounding temperature for operation	–15 °C to +40 °C
Relative humidity	5% to 95%, no condensation
Installation altitude	$\leq$ 1000 m above sea level
Shock load	$\leq$ 50 m/s <sup>2</sup> (5 g), 6 ms in accordance with EN 60068-2-27

#### Notes

- STOBBER synchronous servo motors are not suitable for potentially explosive atmospheres.
- Secure the power cables close to the motor so that vibrations of the cable do not place impermissible loads on the motor plug connector.
- Note that the braking torques of the holding brake (optional) may be reduced by shock loading.
- At operating temperatures below 0 °C, note that the discs of the holding brake (optional) may ice up.
- Also take into consideration the shock load of the motor due to output units (such as gearboxes and pumps) which are coupled with the motor.

## 7.6.4 Encoders

STOBER synchronous servo motors can be designed with different encoder models. The following chapters include information for choosing the optimal encoder for your application.

### 7.6.4.1 Encoder measuring method selection tool

The following table offers a selection tool for an encoder measuring method that is optimally suited for your application.

Feature	Absolute encoder		Resolvers
Measuring method	Optical	Inductive	Electromagnetic
Temperature resistance	★★☆	★★★	★★★
Vibration strength and shock resistance	★★☆	★★★	★★★
System accuracy	★★★	★★☆	★★☆
Safety-related position measuring system for use in safety-oriented applications	√ <sup>3</sup>	√ <sup>4</sup>	–
Elimination of referencing with multi-turn design (optional)	✓	✓	–
Simple commissioning with electronic nameplate	✓	✓	–

Key: ★☆☆ = satisfactory, ★★☆☆ = good, ★★★ = very good

### 7.6.4.2 Selection tool for EnDat interface

The following table offers a selection tool for the EnDat interface of absolute encoders.

Feature	EnDat 2.1	EnDat 2.2	EnDat 3
Short cycle times	★★☆	★★★	★★★
Transfer of additional information along with the position value	–	✓	✓
Expanded power supply range	★★☆	★★★	★★★
One Cable Solution (OCS)	–	–	✓

Key: ★☆☆ = good, ★★★ = very good

### 7.6.4.3 EnDat 3 encoders

EnDat 3 is a robust, purely digital protocol that functions with minimal connection lines. EnDat 3 facilitates the One Cable Solution, which allows the connection lines between the encoder and drive controller to be routed along in the motor's power cable.

The One Cable Solution offers the following advantages:

- Significantly reduced wiring effort by eliminating the encoder cable
- For cable lengths up to 50 m, a choke between the drive controller and motor is not necessary
- Extended safety functions possible (up to SIL 2 / category 3, PL d)
- Significantly reduced space requirements by eliminating the encoder plug connector
- Transmission of measured values from the temperature sensor using the EnDat 3 protocol

A motor with an EnDat 3 encoder can be operated only on a SB6, SC6 or SI6 drive controller from STOBER.

The EnDat 3 encoder has the following features:

Encoder model	Code	Measuring method	Recordable revolutions	Resolution	Position values per revolution	MTTF [years]	PFH [h]
EnDat 3 EQI 1131 Safety	S7	Inductive	4096	19 bit	524288	> 100	≤ 15 × 10 <sup>-9</sup>

### 7.6.4.4 EnDat 2 encoders

In this chapter, you can find detailed technical data for encoder models with EnDat 2 interface that can be selected.

<sup>3</sup>The EnDat 2.1 EQN 1125 encoder does not have FS certification from the manufacturer. However, the mechanical attachment complies with the specifications for FS devices.

<sup>4</sup>Not for EnDat 2.2 ECI 1118-G2 encoders

## Encoders with EnDat 2.2 interface

Encoder model	Code	Measuring method	Recordable revolutions	Resolution	Position values per revolution	MTTF [years]	PFH [h]
EnDat 2.2 EQI 1131 Safety	S2	Inductive	4096	19 bit	524288	> 100	$\leq 15 \times 10^{-9}$
EnDat 2.2 ECI 1118-G2	C5	Inductive	–	18 bit	262144	> 76	$\leq 1.5 \times 10^{-6}$
EnDat 2.2 EQN 1135 Safety	S3	Optical	4096	23 bit	8388608	> 100	$\leq 15 \times 10^{-9}$

## Encoders with EnDat 2.1 interface

Encoder model	Code	Measuring method	Recordable revolutions	Resolution	Position values per revolution	Periods per revolution	MTTF [years]	PFH [h]
EnDat 2.1 EQN 1125	Q4	Optical	4096	13 bit	8192	Sin/cos 512	> 57	$\leq 2 \times 10^{-6}$
EnDat 2.1 ECI 1118-G3	C2	Inductive	–	18 bit	262144	Sin/cos 16	> 100	$\leq 6 \times 10^{-7}$
EnDat 2.1 EQI 1130-G3	Q2	Inductive	4096	18 bit	262144	Sin/cos 16	> 100	$\leq 6 \times 10^{-7}$

## Notes

- The encoder code is a part of the type designation of the motor.
- Safety = Safety-related position measuring system for use in safety-oriented applications.
- MTTF = Average time before dangerous failure. MTTF values greater than 100 years were reduced in accordance with DIN EN ISO 13849.
- PFH = Probability of a dangerous failure per hour.
- Multiple revolutions of the motor shaft can be recorded only using multi-turn encoders.

## 7.6.4.5 Resolver

In this chapter, you can find detailed technical data for the resolver that can be installed as an encoder in a STOBBER motor.

Feature	Description
Code	R0
Number of poles	2
Input voltage $U_{1\text{eff}}$	$7 \text{ V} \pm 5\%$
Input frequency $f_1$	10 kHz
Output voltage $U_{z,S1-S3}$	$K_{tr} \cdot U_{R1-R2} \cdot \cos \theta$
Output voltage $U_{z,S2-S4}$	$K_{tr} \cdot U_{R1-R2} \cdot \sin \theta$
Transformation ratio $K_{tr}$	$0.5 \pm 5\%$
Electrical fault	$\pm 10$ arcmin
MTTF	> 100 years
PFH	$\leq 10^{-9}$

### 7.6.4.6 Possible combinations with drive controllers

The following table shows the options for combining STOBER drive controllers with selectable encoder models.

Drive controller		SB6			SC6			SI6			SD6	
Drive controller code		BC	BD	BE	AU	AV	BA	AP	AQ	BB	AD	AE
Connection plan ID		443376	443377	443378	443052	443053	443174	442771	442772	443175	442450	442451
Encoder	Encoder code											
EnDat 3 EQI 1131 Safety	S7	–	✓	–	–	–	✓	–	–	✓	–	–
EnDat 2.2 EQI 1131 Safety	S2	✓	–	–	✓	–	–	✓	–	–	✓	–
EnDat 2.2 EQN 1135 Safety	S3	✓	–	–	✓	–	–	✓	–	–	✓	–
EnDat 2.2 ECI 1118-G2	C5	✓	–	–	✓	–	–	✓	–	–	✓	–
EnDat 2.1 EQN 1125	Q4	–	–	✓	–	–	–	–	–	–	–	✓
EnDat 2.1 ECI 1118-G3	C2	–	–	✓	–	–	–	–	–	–	–	✓
Resolvers	R0	–	–	✓	–	✓	–	–	✓	–	–	✓

#### Notes

- The drive controller and encoder codes are a part of the type designation of the motor (see the chapter [▶ 7.5](#)).

### 7.6.5 Temperature sensor

In this chapter, you can find technical data for the temperature sensors that are installed in STOBER synchronous servo motors for implementing thermal winding protection. To prevent damage to the motor, always monitor the temperature sensor with appropriate devices that will turn off the motor if the maximum permitted winding temperature is exceeded.

Some encoders feature integrated temperature monitoring, the warning and switch-off thresholds of which may overlap with the corresponding values set for the temperature sensor in the drive controller. In some cases, this may result in an instance where an encoder with internal temperature monitoring forces the motor to shut down, even before the motor has reached its nominal data.

Information about the electrical connection of the temperature sensor can be found in the chapter [▶ 7.6.8](#).

### 7.6.5.1 PTC thermistor

The PTC thermistor is installed as a standard temperature sensor in STOBBER synchronous servo motors.

The PTC thermistor is a triple thermistor in accordance with DIN 44082 that can be used for monitoring the temperature of each winding phase. The resistance values in the following table and curve refer to a single thermistor in accordance with DIN 44081. These values must be multiplied by 3 for a triple thermistor in accordance with DIN 44082.

Feature	Description
Nominal response temperature $\vartheta_{NAT}$	145 °C ± 5 K
Resistance R -20 °C up to $\vartheta_{NAT} - 20$ K	≤ 250 Ω
Resistance R with $\vartheta_{NAT} - 5$ K	≤ 550 Ω
Resistance R with $\vartheta_{NAT} + 5$ K	≥ 1330 Ω
Resistance R with $\vartheta_{NAT} + 15$ K	≥ 4000 Ω
Operating voltage	≤ DC 7.5 V
Thermal response time	< 5 s
Thermal class	155 (F) in accordance with EN 60034-1 (155 °C, heating $\Delta\vartheta = 100$ K)

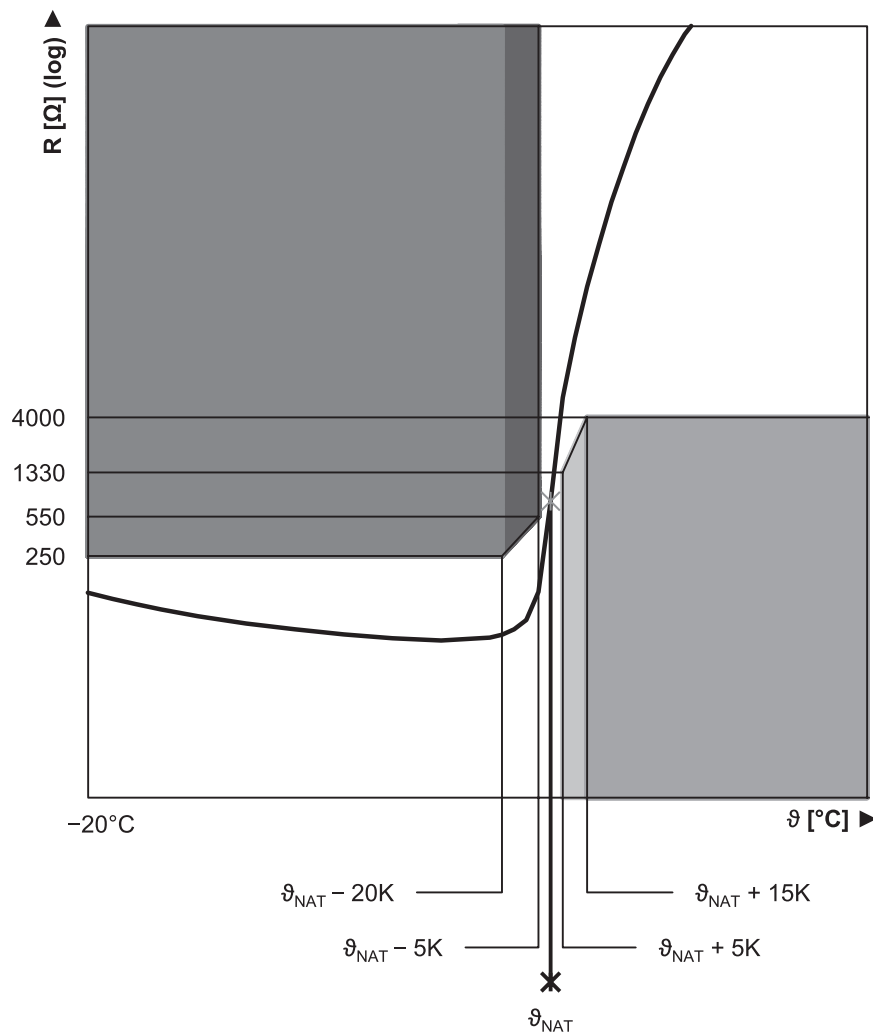

Fig. 2: PTC thermistor curve (single thermistor)

### 7.6.5.2 Pt1000 temperature sensor

STOBER synchronous servo motors are available in versions with a Pt1000 temperature sensor. The Pt1000 is a temperature-dependent resistor that has a resistance curve with a linear relationship with temperature. As a result, the Pt1000 allows for measurements of the winding temperature. These measurements are limited to one phase of the motor winding, however. In order to adequately protect the motor from exceeding the maximum permitted winding temperature, use a  $i^2t$  model in the drive controller to monitor the winding temperature.

Pt1000 temperature sensors can also be used with the One Cable Solution.

Avoid exceeding the specified measurement current so that the measured values are not falsified due to self-heating of the temperature sensor.

Feature	Description
Measurement current (constant)	2 mA
Resistance R for $\vartheta = 0\text{ °C}$	1000 $\Omega$
Resistance R for $\vartheta = 80\text{ °C}$	1300 $\Omega$
Resistance R for $\vartheta = 150\text{ °C}$	1570 $\Omega$

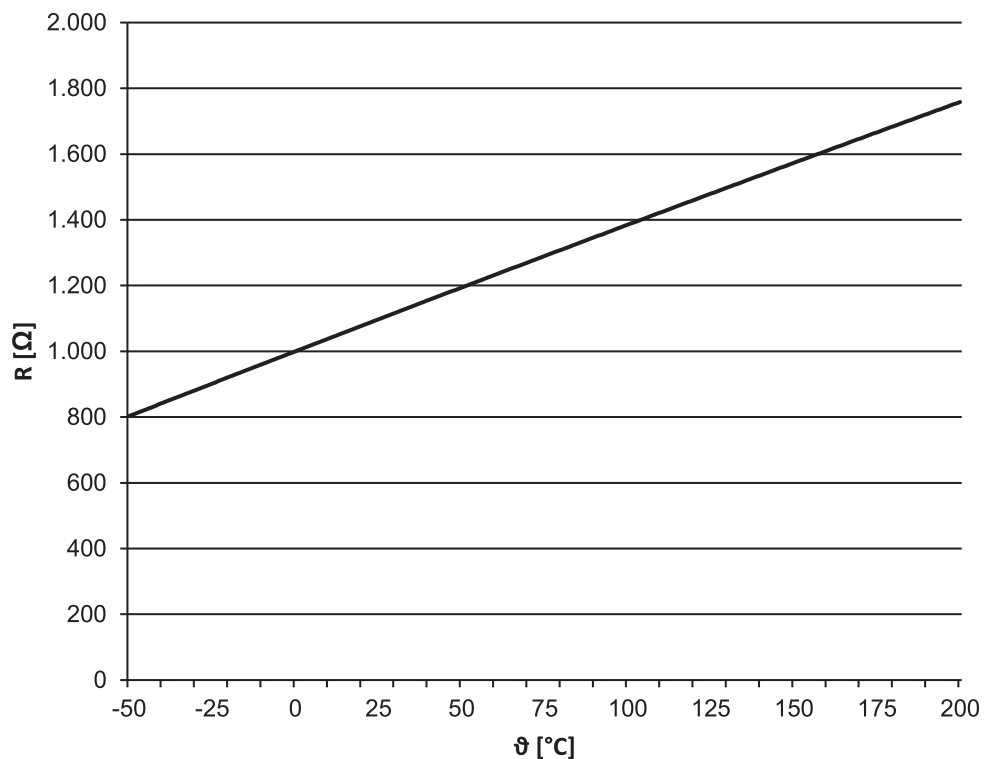

Fig. 3: Pt1000 temperature sensor characteristic curve

## 7.6.6 Cooling

A synchronous servo motor in the standard version is cooled by convection cooling (IC 410 in accordance with EN 60034-6). Optionally, forced ventilation can be used to cool the motor.

### 7.6.6.1 Forced ventilation



STOBER synchronous servo motors offer the option of being cooled with forced ventilation in order to increase performance data while maintaining the same size. Retrofitting with a forced ventilation unit is also possible in order to optimize the drive at a later date. When retrofitting, check whether the conductor cross-section of the power cable of the motor must be increased. Also take into account the dimensions of the forced ventilation unit.

The performance data for motors with forced ventilation can be found in the chapter [\[ 7.2 \]](#) and the dimensional drawings in the chapter [\[ 7.4 \]](#).

## Technical data

Motor	Forced ventilation unit	$U_{N,F}$ [V]	$I_{N,F}$ [A]	$P_{N,F}$ [W]	$q_{VF}$ [m <sup>3</sup> /h]	$L_{pA,F}$ [dB(A)]	$m_F$ [kg]	Protection class
EZ4_B	FL4	230 V ± 5%, 50/60 Hz	0.07	10	59	41	1.4	IP44
EZ5_B	FL5		0.10	14	160	45	1.9	IP54
EZ7_B	FL7		0.10	14	160	45	2.9	IP54
EZ8_B	FL8		0.20	26	420	54	5.0	IP55

## Terminal assignment for forced ventilation unit plug connectors

Connection diagram	Pin	Connection
	1	L1 (phase)
	2	N (neutral conductor)
	3	
		PE (grounding conductor)

## 7.6.7 Holding brake

STOBER synchronous servo motors can be equipped with a backlash-free holding brake using permanent magnets in order to secure the motor shaft when at a standstill. The holding brake engages automatically if the voltage drops.

The holding brake is designed for a high number of operations ( $B_{10} = 10$  million operations,  $B_{10d} = 20$  million operations).

Nominal voltage of permanent magnet holding brake: DC 24 V ± 5%, smoothed.

## Observe the following during project configuration:

- The holding brake is designed to keep the motor shaft from moving. Activate braking processes during operation using the corresponding electrical functions of the drive controller. In exceptional circumstances, the holding brake can be used for braking from full speed (following a power failure or when setting up the machine). The maximum permitted work done by friction  $W_{B,Rmax/h}$  may not be exceeded.
- Note that when braking from full speed, the braking torque  $M_{Bstat}$  may initially be more than 50% lower. As a result, the braking effect has a delayed action and braking distances become longer.
- Regularly perform a brake test to ensure the functional safety of the brakes. Details can be found in the documentation of the motor and the drive controller.
- Connect a varistor of type S14 K35 (or comparable) in parallel to the brake coil to protect your machine from switching surges. (Not necessary for connecting the holding brake to STOBER drive controllers of the 5th and 6th generation with a BRS/BRM brake module).
- The holding brake of the motor does not offer adequate safety for persons in the hazardous area of gravity-loaded vertical axes. Therefore take additional measures to minimize risk, e.g. by providing a mechanical substructure for maintenance work.
- Take into consideration voltage losses in the connection cables that connect the voltage source to the holding brake connections.
- The holding torque of the brake can be reduced by shock loading. Information about shock loading can be found in the chapter [▶ 7.6.3].
- At operating temperatures from -15 °C to 0 °C, a cold holding brake in the released state may cause operating noises. As the temperature of the holding brake increases, these noises decrease such that operating noises are not heard when using holding brake at operating temperature in the released state.

## Calculation of work done by friction per braking process

$$W_{B,R/B} = \frac{J_{tot} \cdot n^2}{182.4} \cdot \frac{M_{Bdyn}}{M_{Bdyn} \pm M_L}, \quad M_{Bdyn} > M_L$$

The sign of  $M_L$  is positive if the movement runs vertically upwards or horizontally and it is negative if the movement runs vertically down.

## Calculation of the stop time

$$t_{\text{dec}} = 2.66 \cdot t_{1B} + \frac{n \cdot J_{\text{tot}}}{9.55 \cdot M_{\text{Bdyn}}}$$

## Switching behavior

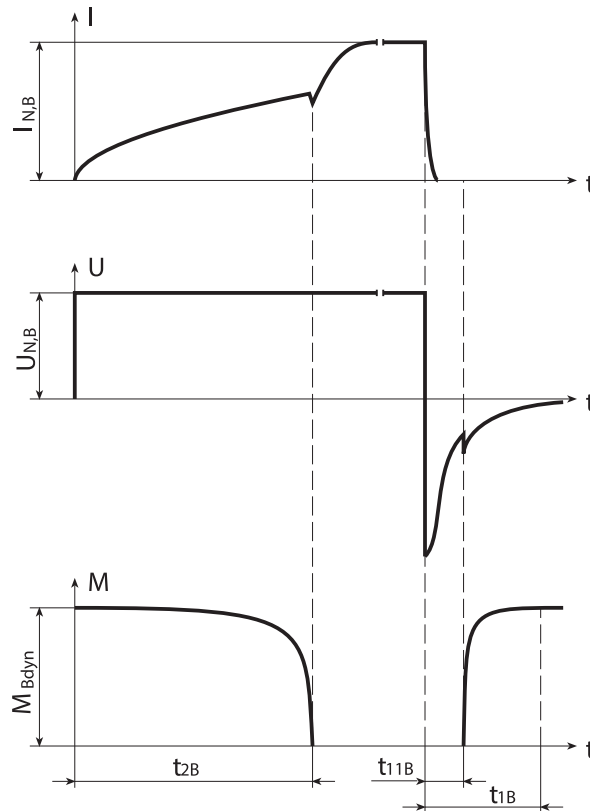

Fig. 4: Holding brake – Switching behavior

## Technical data

Type	$M_{Bstat}$ [Nm]	$I_{N,B}$ [A]	$W_{B,Rmax/h}$ [kJ/h]	$N_{Bstop}$	$J_{Bstop}$ [kgcm <sup>2</sup> ]	$W_{B,Rlim}$ [kJ]	$t_{2B}$ [ms]	$t_{11B}$ [ms]	$t_{1B}$ [ms]	$x_{B,N}$ [mm]	$\Delta J_B$ [kgcm <sup>2</sup> ]	$\Delta m_B$ [kg]
EZ202	1.2	0.36	3.0	45000	0.31	70	10	2.0	5.0	0.15	0.03	0.25
EZ203	1.2	0.38	3.0	36000	0.39	70	10	2.0	5.0	0.15	0.03	0.25
EZ301	2.5	0.51	6.0	48000	0.75	180	25	3.0	20	0.20	0.19	0.55
EZ302	4.0	0.50	8.5	38000	0.95	180	44	4.0	26	0.30	0.19	0.55
EZ303	4.0	0.50	8.5	30000	1.17	180	44	4.0	26	0.30	0.19	0.55
EZ401	4.0	0.50	8.5	16000	2.24	180	44	4.0	26	0.30	0.19	0.76
EZ402	8.0	0.75	8.5	13500	4.39	300	40	2.0	20	0.30	0.57	0.97
EZ404	8.0	0.75	8.5	8500	7.09	300	40	2.0	20	0.30	0.57	0.97
EZ501	8.0	0.75	8.5	8700	6.94	300	40	2.0	20	0.30	0.57	1.2
EZ502	8.0	0.80	8.5	5200	11.5	300	40	2.0	20	0.30	0.57	1.2
EZ503	15	1.00	11.0	5900	18.6	550	60	5.0	30	0.30	1.72	1.6
EZ505	15	1.00	11.0	4000	27.8	550	60	5.0	30	0.30	1.72	1.6
EZ701	15	1.00	11.0	5400	20.5	550	60	5.0	30	0.30	1.74	1.9
EZ702	15	1.00	11.0	3600	30.9	550	60	5.0	30	0.30	1.74	1.9
EZ703	32	1.10	25.0	5200	54.6	1400	100	5.0	25	0.40	5.68	2.8
EZ705	32	1.10	25.0	3500	79.4	1400	100	5.0	25	0.40	5.68	2.8
EZ813	65	1.70	45.0	4500	200	2250	200	10	50	0.40	16.5	5.4
EZ815	115	2.10	65.0	7000	376	6500	190	12	65	0.50	55.5	8.4

## 7.6.8 Connection method

The following chapters describe the connection technology of STOBER synchronous servo motors in the standard version on STOBER drive controllers. You can find further information relating to the drive controller type that was specified in your order in the connection plan that is delivered with every synchronous servo motor.

### 7.6.8.1 Connection of the motor housing to the grounding conductor system

Connect the motor housing to the machine's grounding conductor system to protect persons.

All attachment parts required for the connection of the grounding conductor to the motor housing are delivered with the motor. The grounding screw of the motor is identified with the symbol  $\oplus$  in accordance with IEC 60417-DB. The cross-section of the grounding conductor has to be at least as large as the cross-section of the lines in the power connection.

### 7.6.8.2 Plug connectors (One Cable Solution)

In the One Cable Solution design, the power and encoder lines are connected using a shared plug connector.

For motors with forced ventilation, avoid collisions between the motor connection cables and the plug connector of the forced ventilation unit. In the event of a collision, rotate the plug connectors of the motor by the required angle. Details on the position of the plug connector for the forced ventilation unit can be found in the chapter [\[ 7.4.5 \]](#).

The figures represent the position of the plug connectors upon delivery.

#### Turning ranges of plug connectors (EZ2 – EZ3 motors)

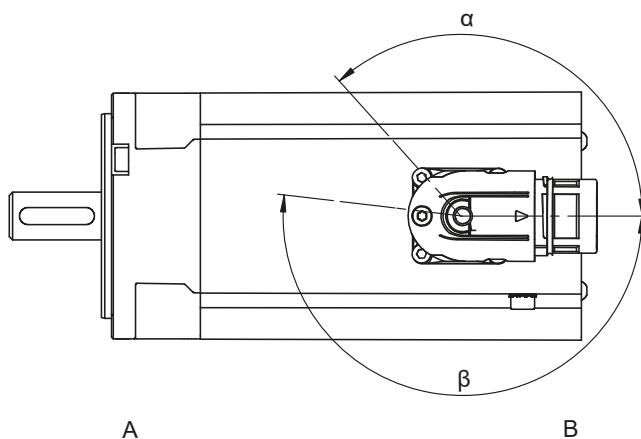

A	Attachment or output side of the motor	B	Not output side
---	--	---	-----------------

#### Turning ranges of plug connectors (EZ4 – EZ7 motors)

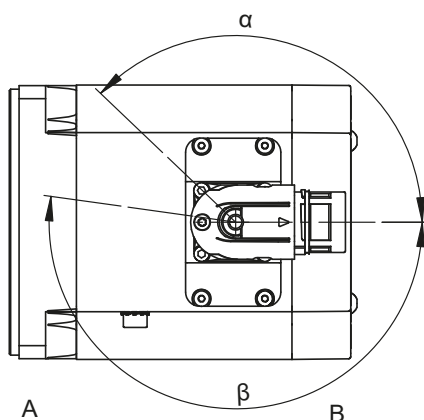

A	Attachment or output side of the motor	B	Not output side
---	--	---	-----------------

**Plug connector features**

Motor type	Size	Connection	Turning range	
			$\alpha$	$\beta$
EZ2 – EZ5, EZ701 – EZ703, EZ705U	con.23	Quick-lock	130°	190°

**Notes**

- The number after "con." indicates the approximate external thread diameter of the plug connector in mm (for example, con.23 designates a plug connector with an external thread diameter of about 23 mm).

**7.6.8.3 Plug connectors**

STOBER The standard version of synchronous servo motors is equipped with rotatable quick-lock plug connectors<sup>5</sup>. Details can be found in this chapter.

For motors with forced ventilation, avoid collisions between the motor connection cables and the plug connector of the forced ventilation unit. In the event of a collision, rotate the plug connectors of the motor by the required angle. Details on the position of the plug connector for the forced ventilation unit can be found in the chapter [▶ 7.4.6].

The figures represent the position of the plug connectors upon delivery.

**Turning ranges of plug connectors (EZ2 – EZ3 motors)**

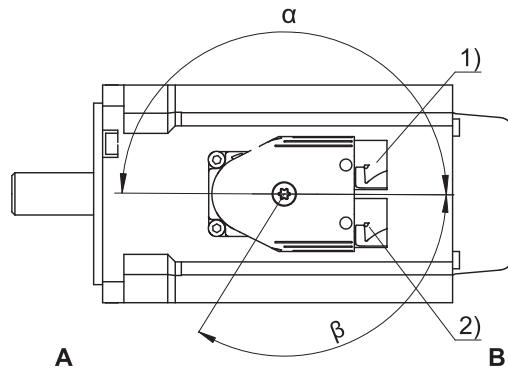

- 1 Power plug connector
- 2 Encoder plug connector
- A Attachment or output side of the motor
- B Not output side

**Turning ranges of plug connectors (EZ4 – EZ8 motors)**

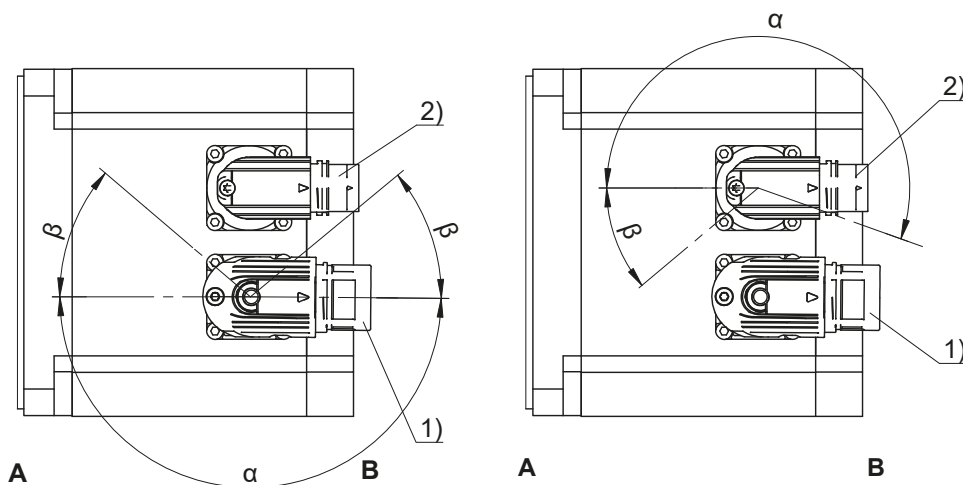

- 1 Power plug connector
- 2 Encoder plug connector
- A Attachment or output side of the motor
- B Not output side

<sup>5</sup>The connectors can be pivoted up to 10 times at a specific angle. They cannot be rotated repeatedly.

**Power plug connector features**

Motor type	Size	Connection	Turning range	
			$\alpha$	$\beta$
EZ2, EZ3	con.15	Quick-lock	180°	120°
EZ4, EZ5, EZ701, EZ702, EZ703	con.23	Quick-lock	180°	40°
EZ705, EZ8	con.40	Quick-lock	180°	40°

**Encoder plug connector features**

Motor type	Size	Connection	Turning range	
			$\alpha$	$\beta$
EZ2, EZ3	con.15	Quick-lock	180°	120°
EZ4, EZ5, EZ7, EZ8	con.17	Quick-lock	190°	35°

**Notes**

- The number after "con." indicates the approximate external thread diameter of the plug connector in mm (for example, con.23 designates a plug connector with an external thread diameter of about 23 mm).
- In turning range  $\beta$ , the power or encoder plug connectors can be turned only if doing so does not cause them to collide.
- For the EZ2/EZ3 motor, the power and encoder plug connectors are mechanically connected and can only be turned together.

**7.6.8.4 Terminal assignment for plug connectors (One Cable Solution)**

In the One Cable Solution design, the power and encoder lines are connected using a shared plug connector. The temperature sensor of the motor is connected to the encoder internally. The measured values from the temperature sensor are transmitted via the EnDat 3 protocol of the encoder.

**Plug connector size con.23**

Connection diagram	Pin	Connection
	A	1U1 (U phase)
	B	1V1 (V phase)
	C	1W1 (W phase)
	E	P_SD -
	F	
	G	1BD1 (brake +)
	H	P_SD +
	L	1BD2 (brake -)
⊕	PE (grounding conductor)	



**7.6.8.5 Connection assignment of the power plug connector**

The size and connection diagram of the power plug connector depend on the size of the motor.

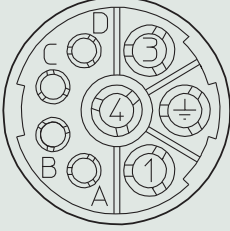

**Plug connector size con.15**

Connection diagram	Pin	Connection
	A	1U1 (U phase)
	B	1V1 (V phase)
	C	1W1 (W phase)
	1	1TP1 (temperature sensor +)
	2	1TP2 (temperature sensor -)
	3	1BD1 (brake +)
	4	1BD2 (brake -)
⊕	PE (grounding conductor)	

**Plug connector size con.23**

Connection diagram	Pin	Connection
	1	1U1 (U phase)
	3	1V1 (V phase)
	4	1W1 (W phase)
	A	1BD1 (brake +)
	B	1BD2 (brake -)
	C	1TP1 (temperature sensor +)
	D	1TP2 (temperature sensor -)
		PE (grounding conductor)

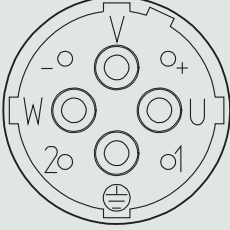
**Plug connector size con.40**

Connection diagram	Pin	Connection
	U	1U1 (U phase)
	V	1V1 (V phase)
	W	1W1 (W phase)
	+	1BD1 (brake +)
	-	1BD2 (brake -)
	1	1TP1 (temperature sensor +)
	2	1TP2 (temperature sensor -)
		PE (grounding conductor)

**7.6.8.6 Connection assignment of the encoder plug connector**

The size and terminal assignment of the encoder plug connectors depend on the model of encoder installed and the size of the motor.

**EnDat 2.2 digital encoder, plug connector size con.15**

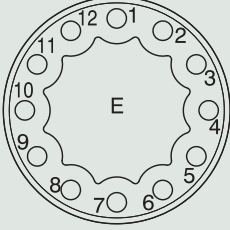
Connection diagram	Pin	Connection
	1	Clock +
	2	Up sense
	3	
	4	
	5	Data -
	6	Data +
	7	
	8	Clock -
	9	
	10	0 V GND
	11	
	12	Up +

**EnDat 2.2 digital encoder, plug connector size con.17**

Connection diagram	Pin	Connection
	1	Clock +
	2	Up sense
	3	
	4	
	5	Data -
	6	Data +
	7	
	8	Clock -
	9	
	10	0 V GND
	11	
	12	Up +

**EnDat 2.1 encoder with sin/cos incremental signals, plug connector size con.15**

Connection diagram	Pin	Connection
	1	Up sense
	2	0 V sense
	3	Up +
	4	Clock +
	5	Clock -
	6	0 V GND
	7	B + (Sin +)
	8	B - (Sin -)
	9	Data +
	10	A + (Cos +)
	11	A - (Cos -)
	12	Data -
	A	
B		
C		

**EnDat 2.1 encoder with sin/cos incremental signals, plug connector size con.17**

Connection diagram	Pin	Connection
	1	Up sense
	2	
	3	
	4	0 V sense
	5	
	6	
	7	Up +
	8	Clock +
	9	Clock -
	10	0 V GND
	11	
	12	B + (Sin +)
	13	B - (Sin -)
	14	Data +
	15	A + (Cos +)
	16	A - (Cos -)
	17	Data -

**Resolver, plug connector size con.15**

Connection diagram	Pin	Connection
	1	S3 Cos +
	2	S1 Cos -
	3	S4 Sin +
	4	S2 Sin -
	5	
	6	
	7	R2 Ref +
	8	R1 Ref -
	9	
	10	
	11	
	12	

## Resolver, plug connector size con.17

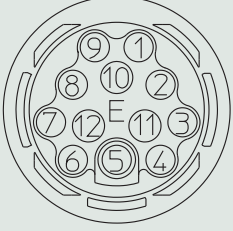
Connection diagram	Pin	Connection
	1	S3 Cos +
	2	S1 Cos -
	3	S4 Sin +
	4	S2 Sin -
	5	
	6	
	7	R2 Ref +
	8	R1 Ref -
	9	
	10	
	11	
	12	

## 7.7 Project configuration

Project your drives using our SERVOfsoft designing software. Download SERVOfsoft free of charge after registration at <https://www.stoeber.de/en/services/info-servosoft/>.

It is the most convenient and reliable method of drive selection, as the entire torque/speed curve of the application is displayed and evaluated here in the curve of the geared motor.

In this chapter, only limit values for specific operating points can be taken into consideration for manual drive selection.

The formula symbols for values actually present in the application are marked with \*.

### 7.7.1 Drive selection

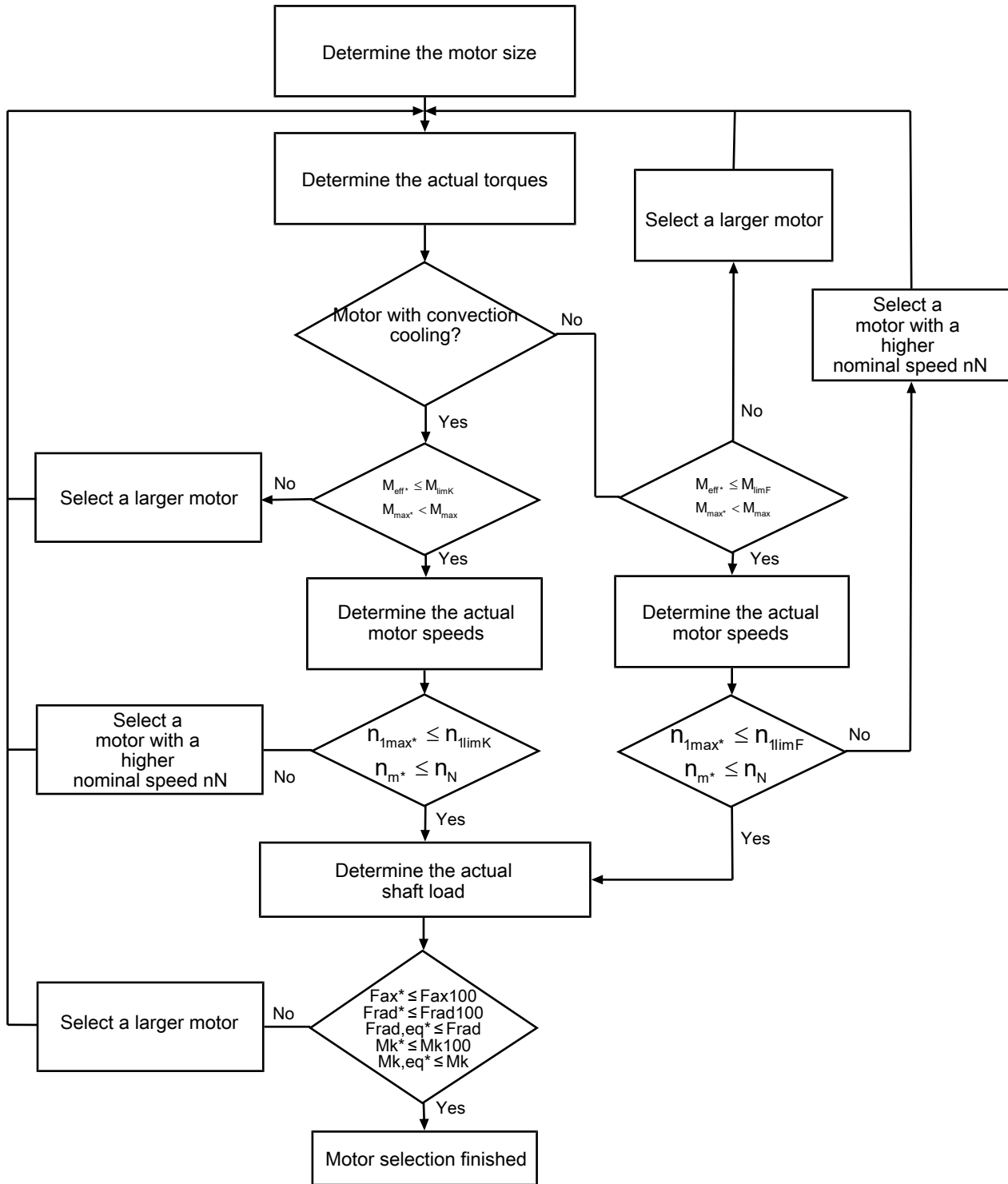

The value for  $M_{lim}$ ,  $M_{limK}$ ,  $M_{limF}$ ,  $M_{max}$ ,  $n_{1limK}$  and  $n_{1limF}$  can be found in the motor characteristic curve in the chapter [7.3](#). Note the size, nominal speed  $n_N$  and cooling type of the motor.

**Example of cyclic operation**

The following calculations refer to a representation of the power delivered at the motor shaft in accordance with the following example:

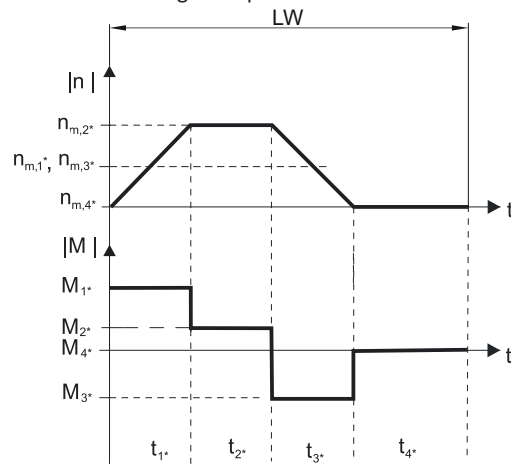
**Calculation of the actual average input speed**

$$n_{m^*} = \frac{|n_{m,1^*}| \cdot t_{1^*} + \dots + |n_{m,n^*}| \cdot t_{n^*}}{t_{1^*} + \dots + t_{n^*}}$$

If  $t_{1^*} + \dots + t_{3^*} \geq 6$  min, determine  $n_{m^*}$  without the rest phase  $t_{4^*}$ .

**Calculation of the actual effective torque**

$$M_{\text{eff}^*} = \sqrt{\frac{t_{1^*} \cdot M_{1^*}^2 + \dots + t_{n^*} \cdot M_{n^*}^2}{t_{1^*} + \dots + t_{n^*}}}$$

## 7.7.2 Permitted shaft loads

This chapter contains information about the maximum permitted shaft loads of the output shaft of the motor.

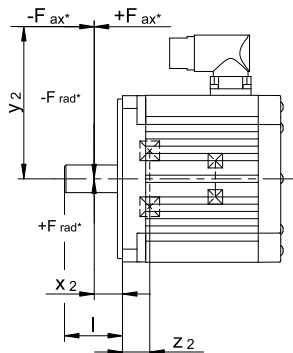

Type	z <sub>2</sub> [mm]	F <sub>ax100</sub> [N]	F <sub>rad100</sub> [N]	M <sub>k100</sub> [Nm]
EZ202	12.0	250	750	20
EZ203	12.0	250	750	20
EZ301	24.0	350	1000	39
EZ302	24.0	350	1000	39
EZ303	24.0	350	1000	39
EZ401	19.5	550	1800	62
EZ402	19.5	550	1800	71
EZ404	19.5	550	1800	71
EZ501	19.5	750	2000	79
EZ502	19.5	750	2400	95
EZ503	19.5	750	2400	107
EZ505	19.5	750	2400	107
EZ701	24.5	1300	3500	173
EZ702	24.5	1300	4200	208
EZ703	24.5	1300	4200	208
EZ705	24.5	1300	4200	225
EZ813	28.5	1750	5600	384
EZ815	28.5	1750	5600	384

The values for permitted shaft loads specified in the table apply:

- For shaft dimensions in accordance with the catalog
- A force applied at the center of the output shaft: x<sub>2</sub> = l / 2 (shaft dimensions can be found in the chapter [▶ 7.4](#))
- Output speeds n<sub>m\*</sub> ≤ 100 rpm (F<sub>ax</sub> = F<sub>ax100</sub>; F<sub>rad</sub> = F<sub>rad100</sub>; M<sub>k</sub> = M<sub>k100</sub>)

The following applies to output speeds n<sub>m\*</sub> > 100 rpm:

$$F_{ax} = \frac{F_{ax100}}{\sqrt[3]{\frac{n_{m*}}{100 \text{ rpm}}}} \quad F_{rad} = \frac{F_{rad100}}{\sqrt[3]{\frac{n_{m*}}{100 \text{ rpm}}}} \quad M_k = \frac{M_{k100}}{\sqrt[3]{\frac{n_{m*}}{100 \text{ rpm}}}}$$

The following applies to other force application points:

$$M_{k*} = \frac{2 \cdot F_{ax*} \cdot y_2 + F_{rad*} \cdot (x_2 + z_2)}{1000}$$

For applications with multiple axial and/or radial forces, you must add the forces as vectors.

**Also note the calculation for equivalent values:**

$$M_{k,eq*} = \sqrt[3]{\frac{|n_{m,1*}| \cdot t_{1*} \cdot |M_{k,1*}|^3 + \dots + |n_{m,n*}| \cdot t_{n*} \cdot |M_{k,n*}|^3}{|n_{m,1*}| \cdot t_{1*} + \dots + |n_{m,n*}| \cdot t_{n*}}}$$

$$F_{rad,eq*} = \sqrt[3]{\frac{|n_{m,1*}| \cdot t_{1*} \cdot |F_{rad,1*}|^3 + \dots + |n_{m,n*}| \cdot t_{n*} \cdot |F_{rad,n*}|^3}{|n_{m,1*}| \cdot t_{1*} + \dots + |n_{m,n*}| \cdot t_{n*}}}$$

### 7.7.3 Derating

If you use the motor under ambient conditions that differ from the standard ambient conditions, the nominal torque  $M_N$  of the motor is reduced. In this chapter, you can find information for calculating the reduced nominal torque.

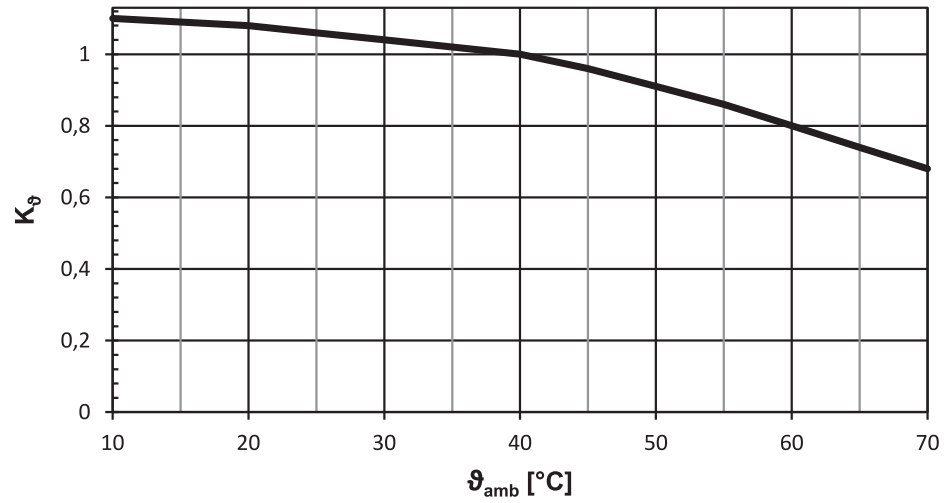

Fig. 5: Derating depending on the surrounding temperature

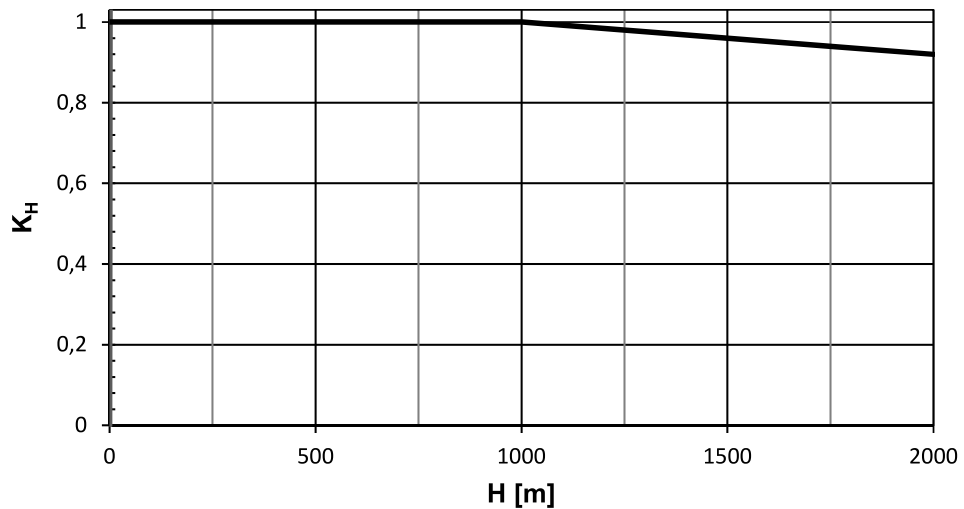

Fig. 6: Derating depending on the installation height

#### Calculation

If surrounding temperature  $\theta_{amb} > 40$  °C:

$$M_{Nred} = M_N \cdot K_\theta$$

If installation altitude  $H > 1000$  m above sea level:

$$M_{Nred} = M_N \cdot K_H$$

If the surrounding temperature  $\theta_{amb} > 40$  °C and installation altitude  $H > 1000$  m above sea level:

$$M_{Nred} = M_N \cdot K_H \cdot K_\theta$$

## 7.8 Further information

### 7.8.1 Directives and standards

STOBER synchronous servo motors meet the requirements of the following directives and standards:

- (Low Voltage) Directive 2014/35/EU
- EN 60034-1: 2010 + Cor.:2010
- EN 60034-5: 2020
- EN 60034-6:1993

### 7.8.2 Identifiers and test symbols

STOBER synchronous servo motors have the following identifiers and test symbols:



CE mark: The product meets the requirements of EU directives.



UKCA mark: The product meets the requirements of UK directives.



cURus test symbol "Servo and Stepper Motors – Component"; registered under UL number E488992 with Underwriters Laboratories USA.

### 7.8.3 Additional documentation

Additional documentation related to the product can be found at

<http://www.stoeber.de/en/downloads/>

Enter the ID of the documentation in the Search term field.

Documentation	ID
Operating manual for EZ synchronous servo motors	443032_en





24

## 8 Close to customers around the world

### Service Network

You can rely on our strong partners when it comes to service. They guide you through commissioning and offer expert technical advice.

### International Service Network

Thanks to our large and long-standing international network, we offer worldwide service and continuous support. In over 40 countries. Put your trust in our expertise.

### Service hotline

+49 7231 582-3000 We are available around the clock.

Do you value international availability and global service? We are here for you.

### STOBER AUSTRIA

[www.stoerber.at](http://www.stoerber.at)  
+43 7613 7600-0  
[sales@stoerber.at](mailto:sales@stoerber.at)

### STOBER FRANCE

[www.stoerber.fr](http://www.stoerber.fr)  
+33 478 98 91 80  
[sales@stoerber.fr](mailto:sales@stoerber.fr)

### STOBER ITALY

[www.stoerber.it](http://www.stoerber.it)  
+39 02 93909570  
[sales@stoerber.it](mailto:sales@stoerber.it)

### STOBER KOREA

[www.stoerber.kr](http://www.stoerber.kr)  
+82 10 5681 6298  
[sales@stoerber.kr](mailto:sales@stoerber.kr)

### STOBER SWITZERLAND

[www.stoerber.ch](http://www.stoerber.ch)  
+41 56 496 96 50  
[sales@stoerber.ch](mailto:sales@stoerber.ch)

### STOBER TURKEY

[www.stoerber.com](http://www.stoerber.com)  
+90 216 510 2290  
[sales-turkey@stoerber.com](mailto:sales-turkey@stoerber.com)

### STOBER USA

[www.stoerber.com](http://www.stoerber.com)  
+1 606 759 5090  
[sales@stoerber.com](mailto:sales@stoerber.com)

### STOBER CHINA

[www.stoerber.cn](http://www.stoerber.cn)  
+86 512 5320 8850  
[sales@stoerber.cn](mailto:sales@stoerber.cn)

### STOBER Germany

[www.stoerber.de](http://www.stoerber.de)  
+49 7231 582-0  
[sales@stoerber.de](mailto:sales@stoerber.de)

### STOBER JAPAN

[www.stoerber.co.jp](http://www.stoerber.co.jp)  
+81-3-5875-7583  
[sales@stoerber.co.jp](mailto:sales@stoerber.co.jp)

### STOBER SWEDEN

[www.stoerber.com](http://www.stoerber.com)  
+46 702 394 675  
[neil.arstad@stoerber.de](mailto:neil.arstad@stoerber.de)

### STOBER TAIWAN

[www.stoerber.tw](http://www.stoerber.tw)  
+886 4 2358 6089  
[sales@stoerber.tw](mailto:sales@stoerber.tw)

### STOBER UK

[www.stoerber.co.uk](http://www.stoerber.co.uk)  
+44 1543 458 858  
[sales@stoerber.co.uk](mailto:sales@stoerber.co.uk)

## 9 Appendix

### Table of contents

9.1 Symbols in formulas .....	220
9.2 Trademarks .....	223
9.3 Sales terms and delivery conditions .....	223

## 9.1 Symbols in formulas

The formula symbols for values actually present in the application are marked with \*.

Symbol	Unit	Explanation
$B_{10}$	–	Number of cycles after which 10% of components have failed
$B_{10D}$	–	Number of cycles until 10% of components have failed dangerously
$C_{dyn}$	N	Dynamic bearing load rating
$C_{maxPU}$	F	Maximum charging capacity of the power unit
$C_{N,PU}$	F	Nominal charging capacity of the power unit
$C_{PU}$	F	Self-capacitance of the power unit
$D_{IA}$	%	Reduction in the nominal current depending on the installation altitude
$D_T$	%	Reduction in the nominal current depending on the surrounding temperature
$\Delta J_B$	kgcm <sup>2</sup>	Additive mass moment of inertia of a motor with brake
$\Delta m_B$	kg	Additive weight of a motor with brake
$ED_{10}$	%	Duty cycle based on 10 minutes
$\eta_{gt}$	%	Efficiency of the screw drive
$f_{2PU}$	Hz	Output frequency of the power unit
$F_{ax}$	N	Permitted axial force on the output
$F_{ax0}$	N	Permitted axial force when the motor is at a standstill for holding the load using the motor torque
$F_{ax,1*} - F_{ax,n*}$	N	Actual axial force in the respective time segment
$F_{ax100}$	N	Permitted axial force on the output for $n_m^* \leq 100$ rpm
$F_{ax300}$	N	Permitted axial force on the output for $n_m^* \leq 300$ rpm
$F_{ax,eff*}$	N	Actual effective axial force on the output
$F_{ax,ss}$	N	Axial force that can be transmitted by the shrink ring
$f_N$	Hz	Rotating magnetic field frequency at nominal speed
$f_{PWM,PU}$	kHz	Frequency of the pulse width modulation of the power unit
$F_{rad}$	N	Permitted radial force on the output
$F_{rad100}$	N	Permitted radial force on the output for $n_m^* \leq 100$ rpm
$F_{rad300}$	N	Permitted radial force on the output for $n_m^* \leq 300$ rpm
H	m	Installation altitude above sea level
$I_0$	A	Stall current
$I_{1maxCU}$	A	Maximum input current of the control unit
$I_{1maxPU}$	%	Maximum input current of the power unit (in relation to the nominal input current)
$I_{1N,PU}$	A	Nominal input current of the power unit
$I_{2maxPU}$	%	Maximum output current of the power unit (in relation to the nominal output current)
$I_{2N,PU}$	A	Nominal output current of the power unit
$I_{2N,PU(red)}$	A	Reduced nominal output current of the power unit
$I_{2N,PU}/I_0$	A	Ratio of the nominal output current of the power unit to the stall current
$I_{2PU(A)}$	A	Output current of the power unit for axis A
$I_{2PU(B)}$	A	Output current of the power unit for axis B
$I_{max}$	A	Maximum current
$I_N$	A	Nominal current
$I_{N,B}$	A	Nominal current of the brake at 20 °C
$I_{N,F}$	A	Nominal current of the forced ventilation unit
$I_{N,MF}$	A	Nominal current of the choke or motor filter
$J_{Bstop}$	kgcm <sup>2</sup>	Reference mass moment of inertia when braking from full speed: $J_{Bstop} = J_{dyn} \times 2$
$J_{dyn}$	kgcm <sup>2</sup>	Mass moment of inertia of a motor in dynamic operation
$J_{tot}$	kgm <sup>2</sup>	Total mass moment of inertia (based on the motor shaft)
$K_{EM}$	V/1000 rpm	Voltage constant: peak value of the induced voltage between the phases U, V, W of the motor at operating temperature at a speed of 1000 rpm
$K_H$	–	Derating factor for installation altitude
$K_{M0}$	Nm/A	Torque constant: ratio of the stall torque and frictional torque to the stall current; $K_{M0} = (M_0 + M_R) / I_0$ (tolerance $\pm 10\%$ )

Symbol	Unit	Explanation
$K_{M,N}$	Nm/A	Torque constant: ratio of the nominal torque $M_N$ to the nominal current $I_N$ ; $K_{M,N} = M_N / I_N$ (tolerance $\pm 10\%$ )
$K_{mot,th}$	–	Factor for determining the thermal limit torque
$K_\theta$	–	Derating factor for surrounding temperature
$l$	mm	Length of the output shaft
$L_{10}$	–	Nominal bearing service life for a survival probability of 90% in $10^6$ rollovers
$L_{10h}$	h	Bearing service life
$L_{pA,F}$	dB(A)	Noise level of the forced ventilation unit in the optimal operating range
$L_{U-V}$	mH	Winding inductance of a motor between two phases (determined in a resonant circuit)
$m$	kg	Weight (for gearboxes without lubricant)
$M_0$	Nm	Stall torque: The continuous torque the motor is able to deliver at a speed of 10 rpm (tolerance $\pm 5\%$ )
$M_{Bstat}$	Nm	Static braking torque of the motor brake at 100 °C
$m_{dyn}$	kg	Weight of a motor in dynamic operation
$M_{eff*}$	Nm	Actual effective torque of the motor
$m_F$	kg	Weight of the forced ventilation unit
$M_k$	Nm	Permitted tilting torque on the output
$M_{k100}$	Nm	Permitted tilting torque on the output for $n_{m*} \leq 100$ rpm
$M_{k300}$	Nm	Permitted tilting torque on the output for $n_{m*} \leq 300$ rpm
$M_L$	Nm	Load torque
$M_{lim}$	Nm	Torque limit without field weakening
$M_{limF}$	Nm	Torque curve of the motor with forced ventilation in continuous operation
$M_{limFW}$	Nm	Torque limit with field weakening (applies to operation on STOBBER drive controllers only)
$M_{limK}$	Nm	Torque curve of the motor with convection cooling in continuous operation
$M_{max}$	Nm	Maximum torque: the maximum permitted torque the motor is able to deliver over a short period (when accelerating or decelerating) (tolerance $\pm 10\%$ )
$M_{n*}$	Nm	Actual torque of the motor in the n-th time segment
$M_N$	Nm	Nominal torque: the maximum torque of a motor in S1 mode at nominal speed $n_N$ (tolerance $\pm 5\%$ )
		You can calculate other torque values as follows: $M_{N*} = K_{M0} \cdot I^* - M_R$ .
$M_{Nred}$	Nm	Reduced nominal torque of the motor
$M_{op}$	Nm	Torque of motor at the operating point from the motor characteristic curve at $n_{1m*}$
$M_R$	Nm	Frictional torque (of the bearings and seals) of a motor at winding temperature $\Delta\theta = 100$ K
$n$	rpm	Speed
$n_{1m*}$	rpm	Actual average input speed
$n_{1max}$	rpm	Maximum permitted input speed
$N_{Bstop}$	–	Permitted number of braking processes from full speed ( $n = 3000$ rpm) with $J_{Bstop}$ ( $M_L = 0$ ). The following applies if the values of $n$ and $J_{Bstop}$ differ: $N_{Bstop} = W_{B,Rlim} / W_{B,R/B}$ .
$n_{m*}$	rpm	Actual average motor speed
$n_{m,n*}$	rpm	Actual average speed of the motor in the n-th time segment
$n_{mot}$	rpm	Speed of the motor
$n_N$	rpm	Nominal speed: The speed for which the nominal torque $M_N$ is specified
$p$	–	Number of pole pairs
$P_{effRB}$	W	Effective power at the external braking resistor
$P_{maxRB}$	W	Maximum power at the external braking resistor
$P_N$	kW	Nominal power: the power the motor is able to deliver long term in S1 mode at the nominal point (tolerance $\pm 5\%$ )
$P_{N,F}$	W	Nominal output of the forced ventilation unit
$P_{2N,PU}$	W	Nominal output power of the power unit
$P_{st}$	mm	Pitch of the screw drive
$R_{U-V}$	$\Omega$	Winding resistance of a motor between two phases at a winding temperature of 20 °C
$P_V$	W	Power loss

Symbol	Unit	Explanation
$P_{V,CU}$	W	Power loss of the control unit
$q_{VF}$	m <sup>3</sup> /h	Delivery capacity of the forced ventilation unit in open air
$R_{2minRB}$	Ω	Minimum resistance of the external braking resistor
$R_{intRB}$	Ω	Resistance of the internal braking resistor
$\vartheta_{amb,max}$	°C	Maximum surrounding temperature
$t$	s	Time
$t_{1B}$	ms	Linking time: time from when the current is turned off until the nominal braking torque is reached
$t_{11B}$	ms	Response delay: time from when the current is turned off until the torque increases
$t_{2B}$	ms	Release time (also: disengagement time) of the brake; time span from when the current is switched off until the brake is completely released
$t_{dec}$	ms	Stop time
$T_{el}$	ms	Electrical time constant: ratio of the winding inductance to the winding resistance of a motor: $T_{el} = L_{U-V} / R_{U-V}$
$t_{n^*}$	s	Duration of the n-th time segment
$\tau_{th}$	°C	Thermal time constant
$\vartheta_{amb}$	°C	Surrounding temperature
$U_{1CU}$	V	Input voltage of the control unit
$U_{1PU}$	V	Input voltage of the power unit
$U_{2PU}$	V	Output voltage of the power unit
$U_{2PU,ZK}$	V	Output voltage of the power unit for the DC link connection (typical values: 400 V <sub>AC</sub> corresponds to 560 V <sub>DC</sub> , 480 V <sub>AC</sub> corresponds to 680 V <sub>DC</sub> )
$U_{max}$	V	Maximum voltage
$U_{N,B}$	V	Nominal voltage of brake
$U_{N,F}$	V	Nominal voltage of the forced ventilation unit
$U_{offCH}$	V	Switch-off threshold of the brake chopper
$U_{onCH}$	V	On limit of the brake chopper
$U_{ZK}$	V	DC link voltage: characteristic value of a drive controller
$v_{ax}$	mm/s	Axial velocity
$v_{ax,m^*}$	mm/s	Actual average axial velocity
$v_{ax,m1^*} - v_{ax,mn^*}$	mm/s	Actual average axial velocity in the respective time segment
$W_{B,R/B}$	J	Work done by friction for braking
$W_{B,Rlim}$	kJ	Work done by friction until wear limit is reached
$W_{B,Rmax/h}$	kJ/h	Maximum permitted work done by friction per hour with individual braking
$x_2$	mm	Distance of the shaft shoulder to the force application point
$x_{B,N}$	mm	Nominal air gap of brake
$y_2$	mm	Distance of the shaft axis to the axial force application point
$z_2$	mm	Distance of the shaft shoulder to the middle of the output bearing

## 9.2 Trademarks

The following names used in connection with the device, its optional equipment and its accessories are trademarks or registered trademarks of other companies:

CANopen <sup>®</sup> , CiA <sup>®</sup>	CANopen <sup>®</sup> and CiA <sup>®</sup> are registered trademarks of CAN in AUTOMATION e.V., Germany, the international user and manufacturer association.
CODESYS <sup>®</sup>	CODESYS <sup>®</sup> is a registered trademark of CODESYS GmbH, Germany.
DESINA <sup>®</sup>	DESINA <sup>®</sup> is a registered trademark of VDW Verein Deutscher Werkzeugmaschinenfabriken e. V., Germany.
EnDat <sup>®</sup>	EnDat <sup>®</sup> and the EnDat <sup>®</sup> logo are registered trademarks of Dr. Johannes Heidenhain GmbH, Germany.
EtherCAT <sup>®</sup> , Safety over EtherCAT <sup>®</sup>	EtherCAT <sup>®</sup> and TwinCAT <sup>®</sup> are registered trademarks and patented technologies, licensed by Beckhoff Automation GmbH, Germany.
HIPERFACE <sup>®</sup>	HIPERFACE <sup>®</sup> and the HIPERFACE DSL <sup>®</sup> logo are registered trademarks of SICK AG, Germany.
Intel <sup>®</sup> , Intel <sup>®</sup> Atom™, Intel <sup>®</sup> Core™	Intel <sup>®</sup> , the Intel <sup>®</sup> logo, Intel <sup>®</sup> Atom™ and Intel <sup>®</sup> Core™ are registered trademarks of Intel Corporation or its subsidiaries in the United States and other countries.
PLCopen <sup>®</sup>	PLCopen <sup>®</sup> is a registered trademark of the PLCopen Organisation, Netherlands.
PROFIBUS <sup>®</sup> , PROFINET <sup>®</sup>	PROFIBUS <sup>®</sup> and PROFINET <sup>®</sup> are registered trademarks of PROFIBUS Nutzerorganisation e.V., Germany.
PROFIdrive <sup>®</sup> , PROFIsafe <sup>®</sup>	PROFIdrive <sup>®</sup> and PROFIsafe <sup>®</sup> are registered trademarks of Siemens AG, Germany.
RINGFEDER <sup>®</sup>	RINGFEDER <sup>®</sup> is a registered trademark of VBG GROUP TRUCK EQUIPMENT GmbH, Germany.
speedtec <sup>®</sup>	speedtec <sup>®</sup> is a registered trademark of TE Connectivity Industrial GmbH, Germany.
Windows <sup>®</sup> , Windows <sup>®</sup> 7, Windows <sup>®</sup> 10, Windows <sup>®</sup> 11	Windows <sup>®</sup> , the Windows <sup>®</sup> logo, Windows <sup>®</sup> XP, Windows <sup>®</sup> 7, Windows <sup>®</sup> 10, and Windows <sup>®</sup> 11 are registered trademarks of Microsoft Corporation in the United States and/or other countries.

## 9.3 Sales terms and delivery conditions

You can find our current sales terms and delivery conditions at <http://www.stoeber.de/en/gtc>.









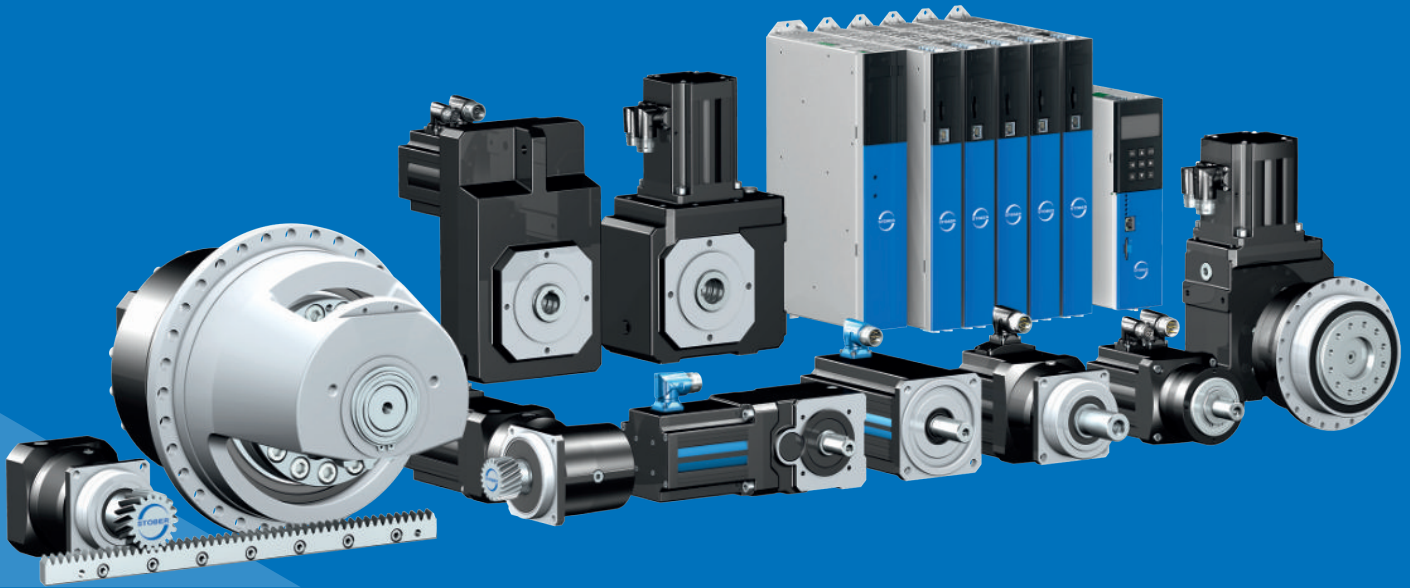

STÖBER Antriebstechnik GmbH + Co. KG  
Kieselbronner Strasse 12  
75177 Pforzheim  
Germany  
Phone: +49 7231 582-0  
mail@stoeber.de  
www.stober.com

Service Hotline  
+49 7231 582-3000

Copyright © STÖBER 2015  
All rights reserved.

