

MB23 – MB53 ServoStop Motor adapter with brake

Operating manual

en-US
01/2024
ID 443287_en.03



STÖBER

Table of contents

1	Overview	3
1.1	Supporting documents	3
2	Product description	4
2.1	Electrical connection	4
3	Mounting the motor to the MB motor adapter	5
4	Roba topstop operating manual	8
5	UK Declaration of Conformity Roba topstop	70
6	Roba switch operating manual	72
7	UK Declaration of Conformity Roba switch	79

1 Overview

A STOBER MB motor adapter with brake is mounted to a STOBER gear unit on the output side upon delivery. The actual MB motor adapter with brake is manufactured by mayr with the product designation **ROBA-topstop**. Therefore, the original operating instructions from mayr are attached to this document (see [Roba topstop operating manual](#) [▶ 8]). The following assignment applies to the individual sizes:

mayr designation on the nameplate	mayr size	STOBER type designation
RTS 120/8993.0XXXX S	120	MB23
RTS 150/8993.0XXXX S	150	MB33
RTS 200/8993.0XXXX S	200	MB43
RTS 260/899.302.12 S	260	MB53

For the STOBER MB motor adapter with brake, a mayr **ROBA-switch** fast acting rectifier can be supplied as an option. The corresponding operating manual can be found in the appendix: [Roba switch operating manual](#) [▶ 72].

1.1 Supporting documents

All technical data of the gear unit with MB motor adapter can be found in the *Servo gear units with brake* catalog with the document ID 443234_en.

The operating manual of the attached gear unit can be found at <https://id.stober.com> by entering the serial number of the gear unit there or by scanning the QR code on the gear unit nameplate.

You can also find the documents mentioned at <http://www.stoeber.de/en/downloads/>. To do so, enter the document ID in the Search... field:

Attached gear unit	ID of the operating manual
P planetary gear unit	443356_en
PH planetary gear unit	443354_en
PHQ planetary gear unit	443353_en
PK right-angle planetary gear unit	443360_en
PHK right-angle planetary gear unit	443358_en
PHQK right-angle planetary gear unit	443357_en
C gear unit	443365_en
F gear unit	443366_en
K gear unit	443364_en

2 Product description

The MB motor adapter is described in the original mayr operating instructions. Observe the following comments on it.

Comment on Chapter 4.1 Scope of Delivery

The MB motor adapter is mounted to a STOBBER gear unit on the output side. The clamping ring hub, coupling element and an O-ring are supplied unassembled.

Comment on Chapter 4.3 Designs

The design of the MB motor adapter corresponds to type 8991.12_ (image 7) on the motor side.



Comment on Chapter 5.2 Technical Data

All dimensions and technical data of your gear unit with MB motor adapter can be found in the STOBBER catalog (see [Supporting documents \[▶ 3\]](#)).

2.1 Electrical connection

Comment on Roba topstop operating manual, chapter 10.11 Electrical connection to the terminal box

The connection to the terminals in the terminal box are made as standard. As an option, other connection versions can be supplied:

Connection diagram	Pin	Terminal	Connection designation
	1	1	+V magnetic coil
	2	2	0 V magnetic coil
			Grounding conductor (PE)

Tab. 1: GSA 2000 device plug mounted on the terminal box

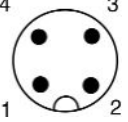
Connection diagram	Pin	Terminal	Connection designation
	1	–	Not assigned
	2	–	Not assigned
	3	1	+V magnetic coil
	4	2	0 V magnetic coil

Tab. 2: M12 flange plug mounted on the terminal box

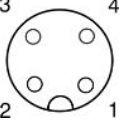
Connection diagram	Pin	Terminal	Connection designation
	1	3	+V release monitoring
	2	–	Not assigned
	3	5	GND release monitoring
	4	4	NO release monitoring

Tab. 3: M12 flange socket mounted on the terminal box

3 Mounting the motor to the MB motor adapter

Mounting the clamping ring hub

Recommendation: Use a spacer ring coordinated to the Y1 or Y2 dimension as a fixed stop for the clamping ring hub.

1. Check whether the length of the motor shaft is in the permitted range (dimension I3 in the following table).
2. Position the motor in the horizontal position.
3. Clean and degrease the motor shaft (1).
4. If present, slide the spacer ring (2) onto the motor shaft.
5. Slide the clamping ring hub (3) onto the motor shaft. If the clamping ring hub does not slide on easily, loosen the clamping screws (4) somewhat.
6. (Without spacer ring): Set dimension Y1 or Y2 in accordance with the following table by moving the clamping ring hub on the motor shaft accordingly.
7. Tighten the clamping screws (4) in several revolutions, alternating diagonally, with the tightening torque according to the following table.
8. Check whether dimension Y1 or Y2 is still correct and correct the position of the clamping ring hub if necessary.

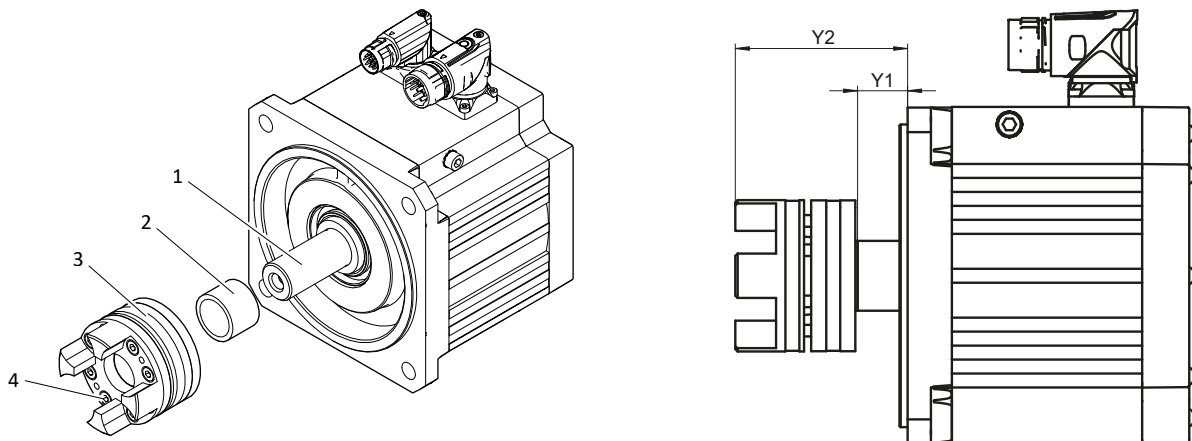

- | | | | |
|---|-------------------|---|----------------|
| 1 | Motor shaft | 2 | Spacer ring |
| 3 | Clamping ring hub | 4 | Clamping screw |

Dimension name	MB23	MB33	MB43	MB53
I3 (shaft length of the motor)	40 – 72	50 – 81	58 – 96	80 – 115
Y1	20	20.5	16	23
Y2	66	73	82	103.5

Tab. 4: Mounting dimension in mm

Note: If you mount the motor using an intermediate flange instead of directly, add the thickness of the intermediate flange to the dimensions I3, Y1 and Y2.

MB23	MB33	MB43	MB53
6	6	10	30

Tab. 5: Tightening torques for the clamping screws (4) in Nm

Mounting the motor to the motor adapter

Prerequisite: Provide four motor adapters of strength class 8.8 for mounting the motor to the MB motor adapter. The dimensions of the threaded holes in the flange of the MB motor adapter can be found in the following table. Minimum screw-in depth = Diameter of the threaded hole x 1.5.

MB23	MB33	MB43	MB53
M8 x 20	M10 x 24	M12 x 28	M16 x 30

Tab. 6: Dimensions of the threaded holes in the motor adapter flange in mm

1. Position your gear unit so that the MB motor adapter is aligned vertically upwards. To do so, if necessary, use a support (13) so that the output shaft (12) is not strained.
2. Position the coupling element (7) in the coupling (14).
3. Position the supplied o-ring (8) in the indent of the MB motor adapter.
4. Place the motor with motor shaft carefully on the flange of the MB motor adapter vertically downward. Make sure that the motor shaft is positioned centrally to the coupling and that the jaws of the clamping ring hub (3) are inserted between the coupling element (7) and the jaws of the coupling (14).
5. Do not use any force when mounting the motor! If necessary, rotate the motor shaft as follows. If the motor has a brake, release the brake before rotating the motor shaft. As an alternative, you can release the brake of the MB motor adapter by energizing it or with manual release (optional) and rotate the gear unit shaft by hand.
6. Make sure that there is no remaining gap between the flange of the MB motor adapter and the motor flange.
7. Mount the motor using four cylinder screws (5) on the MB motor adapter and tighten it with the specified tightening torque (see the following table).

MB23	MB33	MB43	MB53
24	48	83	200

Tab. 7: Tightening torques for the cylinder screws (5) in Nm

Note: The MB motor adapter has a threaded hole on each side, each of which is sealed by one set screw (10). In case of a possible leak in the attached gear unit, the gear oil may flow out through an open threaded hole and thus not reach the brake disk. The leak can then be easily detected during a visual inspection. If fluid cannot get into the interior of the motor adapter through the open threaded hole under operating conditions, remove the set screw on the lowest side of the MB motor adapter. Note that this reduces the IP protection class of the MB motor adapter.

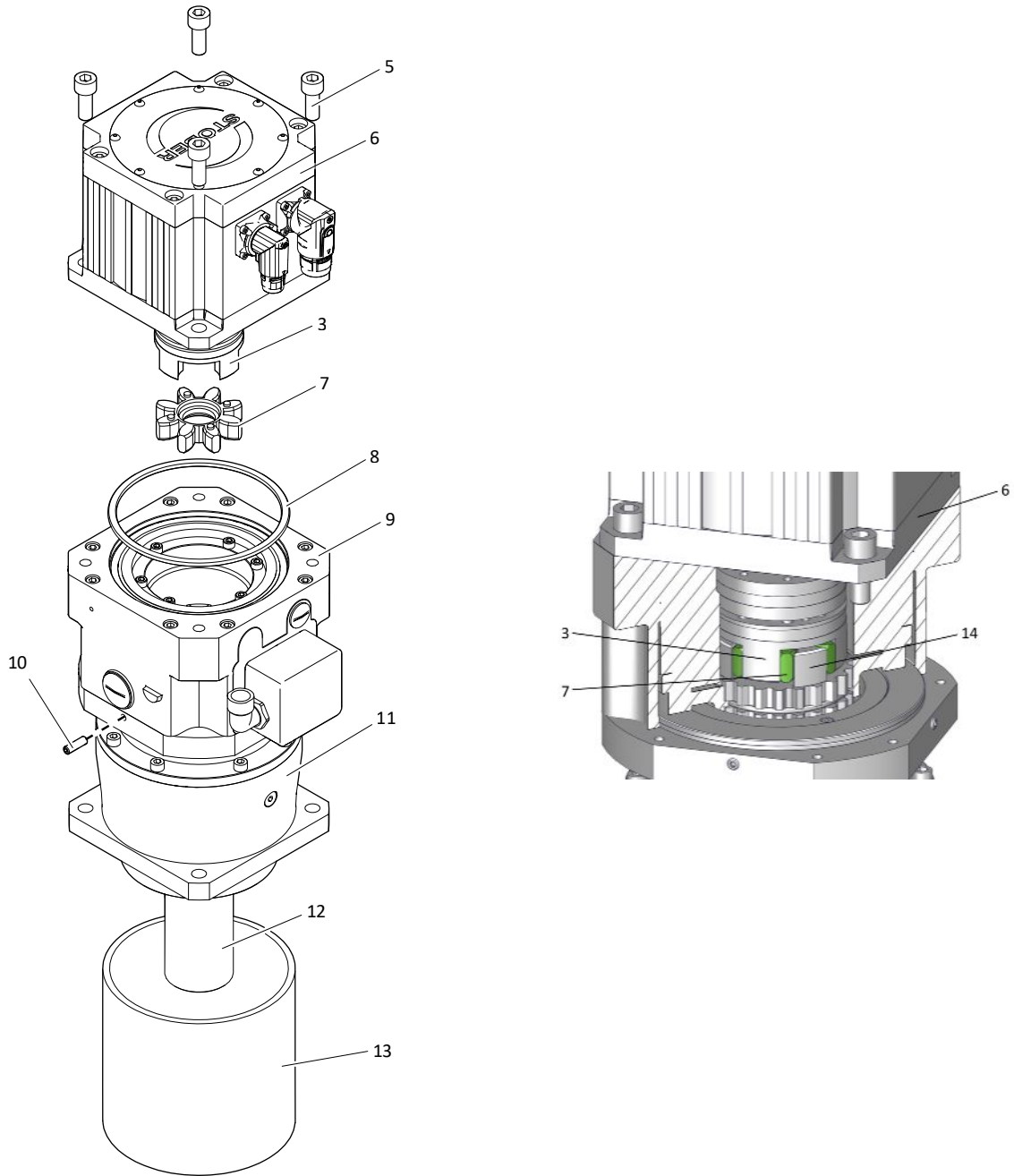

- | | | | |
|----|------------------------|----|---------------------|
| 3 | Clamping ring hub | 5 | Cylinder screw |
| 6 | Motor (example) | 7 | Coupling element |
| 8 | O-ring | 9 | MB motor adapter |
| 10 | Set screw | 11 | Gear unit (example) |
| 12 | Output shaft (example) | 13 | Support (example) |
| 14 | Coupling | | |

4 Roba topstop operating manual

See also

 [BAL Roba topstop 899_en \[▶ 9\]](#)



your reliable partner

Safety Brake in Accordance with the Machinery Directive

ROBA[®]-topstop[®]
Type 899_._ _ _ _ _
Sizes 100 - 260

Issue status 2022-11



Patents applied for

Translation of the Original Operational Instructions B.899.EN

© Copyright by *mayr*[®] – power transmission

All rights reserved.

Reprints and copies – even extracts – are only permitted with the consent of the manufacturer.

Contents

1 Definition of Terms	3	6.7 Outer Parameters	33
2 Safety	4	6.7.1 Permitted Motor Attachments/ Breakdown Torques	33
2.1 Safety and Guideline Signs	4	6.7.2 Permitted Outer Acceleration and Deceleration Torques on the Brake	33
2.2 General Guidelines	4	6.7.3 Permitted Shaft Loads	33
2.2.1 Personnel Requirements	4	7 Electrical Connection and Wiring	34
2.3 Intended Use	5	7.1 Grounding Connection	34
2.4 Handling	5	7.2 Fuse Element	34
2.5 User-implemented Protective Measures	5	7.3 Switching Behavior	34
2.6 Dimensioning Other Machine Elements	5	7.4 Switching Modes	34
3 Legal Provisions	6	7.4.2 Magnetic Field Removal	35
3.1 Directives, Standards and Regulations Used	6	7.5 Protection Circuit	36
3.2 Liability	6	8 Functional Safety Parameters	37
3.3 Guarantee	6	8.1.1 Definition	37
3.4 Guidelines on CE Identification	7	8.1.2 Functional Safety Regulations	37
3.5 Notes on UK guidelines / conformity	8	8.1.3 Condition	38
3.6 Guidelines on EU and UK REACH	8	9 Storage	38
3.7 CE Identification	8	9.1 Brake Storage	38
3.8 UKCA Identification	8	10 Installation	39
3.9 Certification Symbols	8	10.1 Mounting Conditions	39
3.10 Identification/ Type tag	9	10.2 Installation Conditions	39
3.11 Existing Patents	9	10.3 Brake Type 8990.000_ _ _	40
4 Product Description	10	10.4 Brake Type 8990.01_ _ _	41
4.1 Scope of Delivery / State of Delivery	10	10.5 Brake Type 8990.02_ _ _	42
4.2 Function	10	10.6 Brake Type 8990.11_ _ _	43
4.2.1 Quiescent Current Principle	10	10.7 Brake Type 8990.12_ _ _	44
4.2.2 Reliable Braking Function	10	10.8 Brake Type 8991.00_ _ _	45
4.2.3 Release Monitoring	11	10.9 Brake Type 8991.11_ _ _	46
4.3 Designs	12	10.10 Brake Type 8991.12_ _ _	47
4.4 Parts List	14	10.11 Electrical Connection	48
4.5 Dimensions and Tightening Torques	15	10.11.1 Terminal box	48
4.6 Further Designs	16	10.11.2 Plug	48
4.6.1 Shaft with Key	16	10.12 Release Monitoring	49
4.6.2 Hand release	16	10.12.1 General	49
5 Technical Data	17	10.12.2 Release monitoring with proximity switch	50
5.1 Guidelines	17	10.12.3 Release monitoring with microswitch	51
5.1.1 Application Conditions	17	11 Initial Operation	52
5.1.2 Ambient Temperature	17	11.1 Function Test	52
5.1.3 Class of Insulation F (+155 °C)	17	11.2 Brake Test (Static)	52
5.1.4 Protection	17	11.3 Brake Test (Dynamic)	54
5.1.5 Noise Emissions	17	12 Maintenance / Inspections	54
5.2 Technical Data	18	13 Information on the Components	56
5.2.1 Type 8990.000_ _ _	18	13.1 Protective measures and rules of behavior:	56
5.2.2 Type 8990.0_ _ _ _	20	14 Cleaning the Brake	56
5.2.3 Type 8990.1_ _ _ _	22	15 Wear Inspection	57
5.2.4 Type 8991.1_ _ _ _	25	16 De-installation	58
5.2.5 Dimensions with terminal box	27	17 Disposal	58
5.3 Switching Times	28	18 Malfunctions / Breakdowns	59
5.4 Friction Power / Friction Work	30	19 Declaration of Conformity	61
6 Intended Use	31		
6.1 Guidelines for Application	31		
6.2 Limits	31		
6.3 Reasonably Foreseeable Misuse	31		
6.4 Duration of Use	31		
6.5 Application Test	31		
6.6 Brake Dimensioning	32		

Please read these Operational Instructions carefully and follow them accordingly!

Ignoring these Instructions may lead to malfunctions or to brake failure, resulting in damage to other parts. These Operational Instructions are part of the brake delivery.
Please keep them handy and near to the brake at all times.

1 Definition of Terms

Term	Meaning
ROBA®-topstop®	Electromagnetically-actuated safety brakes as a component for holding and deceleration of moved machine parts.
Braking torque M_N Standard	Determined according to VDE 0580/VDI 2241: The theoretical nominal braking torque assigned to the designation. The braking torque lies within the stated braking torque tolerances. The braking torque tolerance is stated in % of the braking torque Standard.
Braking torque M_N Increased	Extended design with a maximum theoretical nominal braking torque which can only be operated with an overexcitation circuit for the magnetic coil. The braking torque tolerance is stated in % of the braking torque Increased.
Test torque	Maximum permissible torque for a brake test by a drive
Load torque	Holding torque which is required to hold a vertical axis (load) suspended, referring to the brake.
Release (separate)	Release designates the procedure through which the magnetic coil is energised, the rotor is released in the brake, and therefore no braking torque is applied.
Close (connect)	Closing or armature disk drop-out designates the process through which the magnetic coil is de-energised, the voltage is switched off, the rotor in the brake is clamped and the braking torque is applied.
Overexcitation	Overexcitation designates when the brake requires a higher supply voltage (= overexcitation voltage) than the coil nominal voltage to release for a short period of time (overexcitation time). Here a ratio of 2:1 or 3:1 is usual.
Overexcitation time	The overexcitation voltage must only be available for a short time for release of the brake. This time from 150ms to 2 s is dependent on the brake size.
Holding voltage	The voltage at which the brake remains permanently released. Usually, this is also the coil nominal voltage for brakes which are not overexcited.
Response delay on connection t_{11} (close)	The time from power switch-off to the start of the braking torque increase (10 % of the stated braking torque).
Connection time t_1 (drop-out time)	The time from power switch-off to achieving 90 % of the stated braking torque.
Separation time t_2 (attraction time) (release)	The time from power switch-on to achieving 10 % of the stated braking torque. At this point, the brake is almost free.
AC-side switching or switching with freewheeling diode	The power circuit is interrupted in front of the rectifier or in front of a freewheeling diode, which is connected parallel to the magnetic coil. The magnetic field slowly reduces and thus causes a substantially longer connection time t_1 . The braking torque is available after a long delay.
DC-side switching	The power circuit is interrupted between the rectifier / the DC power supply and the coil as well as mains-side. The magnetic field reduces extremely quickly and the braking torque quickly becomes available.
Switching distance S_n (proximity switch)	The rated switching distance stated by the manufacturer (on label on proximity switch) at which a signal change takes place under standard conditions.
Varistor (or similar components)	With DC-side switching, the inductive switch-off voltage peaks are to be limited in accordance with VDE 0580. To do this, the installation of voltage-limiting components must be provided. One possibility is protection through a spark quenching unit by mayr® or using a suitable varistor (see www.mayr.com).
Overtravel time/ overtravel path	Temporal duration of the overtravel (= The path of potentially dangerous movement conducted after switch-off)

2 Safety

2.1 Safety and Guideline Signs

Symbol	Signal word	Meaning
	DANGER	Designates a directly pending danger. If not avoided, death or severe injuries will be the consequence.
	WARNING	Designates a possibly hazardous situation. If not avoided, death or severe injuries will be the consequence.
	CAUTION	Designates a hazardous situation. If not avoided, slight or minor injuries can be the consequence.
	ATTENTION	Possible property damage can be the consequence.
	Please Observe	Designates tips for application and other particularly useful information. Not a signal word for dangerous or damaging situations.

2.2 General Guidelines

DANGER



Danger of death! Do not touch voltage-carrying lines and components.



Before product installation and initial operation, please read the Installation and Operational Instructions carefully and observe the Safety Regulations. Incorrect operation can cause injury or damage.

Brakes may generate further risks, among other things:

Hand injuries	Danger of seizure	Contact with hot surfaces	Magnetic fields

- Technical data and specifications (Type tags and documentation) must be followed.
- The correct connection voltage must be connected according to the Type tag and wiring guidelines.
- Check electrical components for signs of damage before putting them into operation. Never bring them into contact with water or other fluids.
- Please observe the EN 60204-1 requirements for electrical connection when using in machines.

Severe injury to people and damage to objects may result if:

- the electromagnetic brake is used incorrectly.
- the electromagnetic brake is modified.
- the relevant standards for safety and / or installation conditions are ignored.



Only carry out installation, maintenance and repairs when the brake is in a de-energised, disengaged condition and secure the system against inadvertent switch-on (acc. EN 50110).

2.2.1 Personnel Requirements

To prevent injury or damage, only professionals and specialists are allowed to work on the components.

They must be familiar with the dimensioning, transport, installation, initial operation, maintenance and disposal according to the relevant standards and regulations.

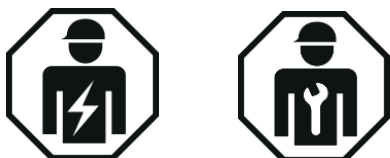

General Guideline:

During the risk assessment required when designing the machine or system, the dangers involved must be evaluated and removed by taking appropriate protective measures in accordance with the Machinery Directive 2006/42/EC.

Brakes for safety-related applications are to be installed singly or as redundant devices in accordance with the required category, in order to fulfil the required Performance Level (PL_r) acc. EN ISO 13849. This is in principle the task of the system manufacturer (see IFA Report 4/2018 section 2.1).

2.3 Intended Use



Use according to the intended purpose is prohibited until it has been determined that the machine / system accords with the EC Directive 2006/42/EC (machinery directive).

mayr®-brakes have been developed, manufactured and tested in compliance with the DIN VDE 0580 standard and in accordance with the EU machinery directive as electromagnetic components. During installation, operation and maintenance of the product, the requirements for the standard must be observed.

ROBA®-topstop® brakes by mayr® prevent inadvertent dropping or crashing of gravity-loaded axes.

- ROBA®-topstop® brakes are intended for use in industrial machines and systems with electrical drives.
- For applications in, for example, defence technology or medical products, **please contact mayr® power transmission.**
- Not suitable for operation in areas where there is a danger of explosion
- Not suitable for applications with combustion engines

The brakes must only be used in the situations for which they are ordered and confirmed. Using them for any other purpose is not allowed.

2.4 Handling

Before installation, the brake must be inspected and found to be in proper condition (visual inspection). The following are not considered as being representative of a proper condition:

- External damage
- External oiling
- External contamination

The brake function must be inspected both **once attachment has taken place** as well as **after longer system downtimes**, in order to prevent the drive starting up against possibly seized linings.

Possible inspection:

- In released condition, the rotor (shaft) must be freely rotatable

2.5 User-implemented Protective Measures

- Attach a cover to protect **against injury through high temperatures** on the housing if high temperatures are conducted for example by the drive motor into the brake housing, thus generating increased temperatures >60 °C on the brake housing (**see section 5.1.1**).

- Protection circuit: see section 7.5**

- Switching times:
DC-side switching is required for fast switching, short connection times and short braking distances. Every further installation of protective elements delays the switching time and therefore also the braking distance.

See section **7** Connection and Wiring

- Install additional protective measures **against corrosion** if the brake is subject to extreme ambient conditions or is installed in open air conditions, unprotected from the weather.
- Take precautions **against freeze-up of the friction surfaces** in high humidity and at low temperatures.
▶ **Please contact mayr® power transmission.**

2.6 Dimensioning Other Machine Elements

The effects of the maximum braking torques on the other machine components must be observed in order to provide sufficient dimensioning.

If more brake components are required, the brake forces may add up depending on the brake layout on the appropriate components.

3 Legal Provisions

3.1 Directives, Standards and Regulations Used

(also to be observed during installation and operation)

DIN VDE 0580	Electromagnetic devices and components, general specifications
DIN EN 61140	Protection against electric shock - Common aspects for installation and equipment
DIN EN IEC 63000	Technical documentation for the assessment of electrical and electronic equipment regarding the restriction of hazardous substances
DIN EN IEC 60529	Degrees of protection provided by enclosures (IP Code)
2014/35/EU	Low voltage directive
2011/65/EU	RoHS II - Directive
2015/863/EU	RoHS III - Directive
CSA C22.2 No. 14-2010	Industrial Control Equipment
UL 508 (Edition 17)	Industrial Control Equipment
EN ISO 12100	Safety of machinery - General principles for design - Risk assessment and risk reduction
DIN EN 61000-6-4	Interference emission
DIN EN 61000-6-2	Interference immunity
EN ISO 13849-2	Safety of machinery Safety related parts of control systems - Validation

3.2 Liability

The information, guidelines and technical data in these documents were up to date at the time of printing. Demands on previously delivered brakes are not valid. Liability for damage and operational malfunctions will not be taken if:

- the Installation and Operational Instructions are ignored or neglected,
- the brakes are used inappropriately.
- the brakes are modified.
- the brakes are worked on unprofessionally.
- the brakes are handled or operated incorrectly.
- Ignoring of further documentation (e.g. B10d letters, drawings, offers, etc.) on the product

3.3 Guarantee

- The guarantee conditions correspond with the Chr. Mayr GmbH + Co. KG sales and delivery conditions (www.mayr.com → Service → General Terms and Conditions)
- Mistakes or deficiencies are to be reported to *mayr*® at once!

3.4 Guidelines on CE Identification



Guidelines on the Declaration of Conformity

A conformity evaluation has been carried out for the product (electromagnetic safety brake) in terms of the EU Low Voltage Directive 2014/35/EU and the RoHS 2011/65/EU with 2015/863/EU. The Declaration of Conformity is laid out in writing in a separate document and can be requested if required.

Guidelines on the EMC Directive 2014/30/EU

The product cannot be operated independently according to the EMC Directive.

Due to their passive state, brakes are also non-critical equipment according to the EMC.

Only after integration of the product into an overall system can this be evaluated in terms of the EMC.

For electronic equipment, the evaluation has been verified for the individual product in laboratory conditions, but not in the overall system.

Guidelines on the Machinery Directive 2006/42/EC

The product is a component for installation into machines according to the Machinery Directive 2006/42/EC.

The brakes can fulfil the specifications for safety-related applications in coordination with other elements.

The type and scope of the required measures result from the machine risk analysis. The brake then becomes a machine component and the machine manufacturer assesses the conformity of the safety device to the directive.

It is forbidden to start initial operation of the product until you have ensured that the machine accords with the regulations stated in the directive.

Guidelines on the EU Directive 2011/65/EU (RoHS II) with 2015/863/EU (RoHS III – from 22 July 2019)

These restrict the use of certain hazardous substances in electrical and electronic devices as well as in products / components (category 11), the proper operation of which is dependent on electric currents and electromagnetic fields. **Our electromagnetic products / components fulfill the requirements laid down in the RoHS Directive(s), taking into account the valid exceptions (according to Appendix III and IV RoHS (2011/65/EU) with delegated Directives (EU) 2018/739-741 from 01.03.2018 for Category 11 – until 21 July 2024) and comply with the RoHS.**

Guidelines on the ATEX Directive

Without a conformity evaluation, this product is not suitable for use in areas where there is a high danger of explosion.

For application of this product in areas where there is a high danger of explosion, it must be classified and marked according to Directive 2014/34/EU.

Guidelines on the REACH Regulation (EC) No. 1907/2006

of the European Parliament and of the Council concerning the Registration, Evaluation, Authorization and Restriction of Chemicals (REACH). This regulation governs the manufacture, placing on the market and use of chemical substances in preparations and, under certain conditions, also of substances in finished products.

mayr® power transmission exclusively manufactures products (articles: overload clutches, shaft couplings, electromagnetic brakes / clutches, permanent magnet motors and the appropriate control modules / rectifiers) in accordance with the definition in Article 3 of the REACH Regulation.

mayr® power transmission is aware of its responsibility towards the environment and society. As a matter of precaution, we pay attention to particularly critical substances in the supply chain and strive to avoid using any such substances completely or to replace them in the near future.

In compliance with Article 33 of the REACH Regulation, we would like to inform you that in our overload clutches and shaft couplings, electromagnetic brakes / clutches as well as permanent magnet motors, sub-components with a lead content of > 0.1% are or may be used. These are manufactured from raw materials such as machining steel / copper alloys (e.g. brass, bronze) or aluminum alloys.

Besides high-melting-point (HMP) solders (electronics), this also affects integrated machine elements as well as standard parts (screws / nuts / set screws / pins / etc.) among others, provided that the relevant standards allow this.

For example, lead can occur as an alloying element with more than 0.1 mass percent, based on the respective total mass, in screws and set screws of the following property classes: 4.6, 4.8, 5.8, 6.8, 04, 4, 5, 6, 14H, 17H, 22H, 33H, 45H.

Products made from copper and copper alloys do not fall within the area of applicability of Regulation (EC) No. 1272/2008 of the European Parliament and Council on the Classification, Labeling and Packaging of Substances and Mixtures (CLP Regulation) and are therefore not subject to the classification and labeling obligations.

To our knowledge, when used for their intended purpose and disposed of correctly (recycling), the contained substances pose no threat to health or environment.

We would like to point out that the proportion of lead used here is not prohibited according to the REACH Regulation. It is merely necessary to declare the use of this substance.

3.5 Notes on UK guidelines / conformity

Products / components from *mayr*® power transmission fulfill the requirements for the British economic area due to currently identical UK and EU directives.

In addition to the CE identification, the UKCA identification is attached to the product.

The UK Declaration of Conformity is available in a separate document.

The UK Declaration of Conformity is available in a separate document.	Guidelines according to UK Declaration
Machinery Directive 2006/42/EC	Supply of Machinery (Safety) Regulations UK 2008 No. 1597
EMC Directive 2014/30/EU	Electromagnetic Compatibility Regulations UK 2016 No. 1091
EU Low Voltage Directive 2014/35/EU	Electrical Equipment (Safety) Regulations UK 2016 No. 1101
RoHS II 2011/65/EU	The Restriction of the Use of Certain Hazardous Substances in Electrical and Electronic Equipment Regulations UK 2012 No. 3032

3.6 Guidelines on EU and UK REACH

According to the European Union (Withdrawal) Act 2018, the EU REACH Regulation was transposed into UK law on January 1, 2021, and is known as UK REACH.

REACH and related legislation have been replicated in the UK with the necessary changes to make it workable in a domestic context.

The fundamental principles of the EU REACH Regulation have been retained in UK REACH.

The remarks on the information obligation according to UK-REACH correspond in content to the REACH Regulation (EC) No. 1907/2006.

3.7 CE Identification

	according to the Machinery Directive 2006/42/EC
---	---

3.8 UKCA Identification

	according to Low Voltage Directive UK 2016 No. 1101 (only for voltage >75 V DC) and / or RoHS Directive UK 2012 No. 3032
---	--

3.9 Certification Symbols

	<p>Certificate: LR 108927-1</p> <p>The brakes are approved up to 300 V in accordance with the Canadian regulations "Canadian Standard Association" (CSA).</p> <p>The installation components used are UL-listed or are applied in conformance with the approval. The CSA conformity marking with the addition of "C" and "US" means that the product has been certified both for the US American market as well as for the Canadian market, and accords with the applicable US American and Canadian standards.</p>
---	---

Operational Instructions for ROBA®-topstop® Type 899_._._._._ Size 100 - 260

(B.899.EN)

3.10 Identification/ Type tag

mayr® components are clearly marked and described on the Type tag:

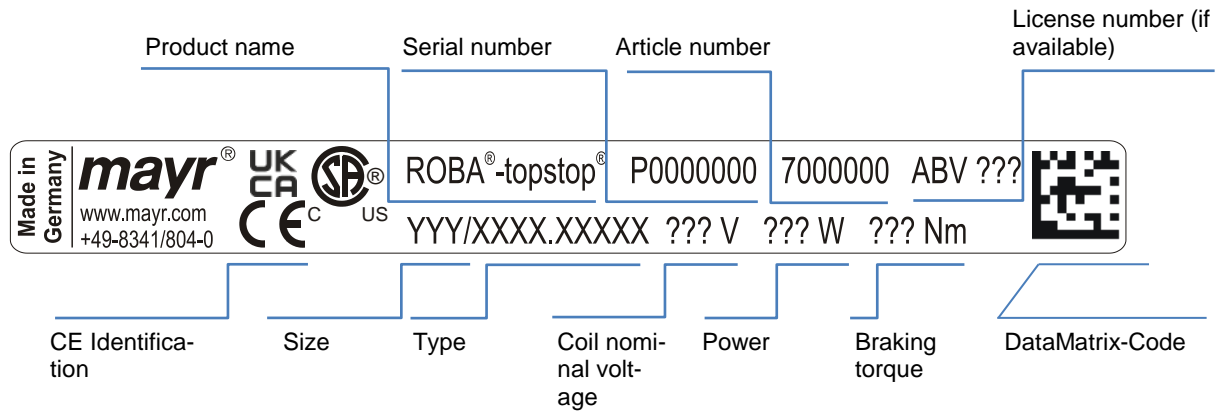

Serial number

Year	Code
2000	A
2001	B
2002	C
2003	D
2004	E
2005	F
2006	H
2007	J
2008	K
2009	L
2010	M
2011	N

Year	Code
2012	P
2013	R
2014	S
2015	T
2016	U
2017	V
2018	W
2019	X
2020	Y
2021	Z
2022	G
2023	Q

3.11 Existing Patents

Patent numbers EP 1 651 883 B1 and CN 101592202 B

4 Product Description

4.1 Scope of Delivery / State of Delivery

- ROBA®-topstop® brakes Type 8990.000 are manufacturer-assembled ready for installation. Each cap screw (10) in the clamping ring (9) is aligned to the screw plug (16).
- The ROBA®-topstop® brakes Type 8990._1_ _ _ and 8990._2_ _ _ are manufacturer-assembled ready for installation on the output side; the respective shrink disk hubs (1) are centred and radially fixed via the rotor (22). The clamping hub (3) or shrink disk hub (5) are included loose in delivery.

ROBA®-topstop® brakes Type 8991._ _ _ _ are pre-assembled. The following are included loose in delivery:

- for Type 8991.000_ _ _ :
 - Rotor (22)
 - Shaft (7) with clamping screw (10)
- for Type 8991.1_ _ _ _ :
 - Rotor (22)
 - Shrink disk hubs (1) with cap screws (2)
 - Elastomeric element (11)
 - Clamping hub (3) with cap screw (4) or
 - Shrink disk hub (5) with cap screws (6).
- Please check the scope of delivery as well as the state of delivery immediately after receiving the goods. *mayr*® will take no responsibility for belated complaints. Please report transport damage immediately to the supplier. Please report incomplete delivery and obvious defects immediately to the manufacturer.

In de-energised condition, several thrust springs press against an armature disk (21). The rotor (22) is clamped between the armature disk (21) and the flange (13) through mounted friction linings, and is braked. The rotor (22) is connected via positive locking with the shaft (7/8/32) or the shrink disk hub (1).

A magnetic force is generated in the coil carrier (20) through application of the coil nominal voltage. The armature disk (21) is attracted against the spring pressure to the coil carrier (20). The rotor becomes free and the brake is released. The shrink disk hub (1) or the shaft (7/8/32) can rotate freely.

4.2.2 Reliable Braking Function

The dimensioning of the thrust springs in the dynamic fatigue strength range avoids a loss of spring force over the lifetime of the brake.

The available braking torque does not reduce by more than 20 % even if a spring fails.

This is achieved through:

- The use of several thrust springs
- The use of thrust springs with a coil distance which is smaller than the wire diameter. In case of wire breakage, the coils cannot wind into each other. The pre-tension on the thrust spring does not reduce to an unpermitted extent and the braking torque remains guaranteed.
→ see ISO 13849-2 Table A2 "Application of proven springs"

Caution Please observe the own weight of the brake



The brake may drop during lifting / transport. The consequences may be crush injuries and impact injuries.

For Size 260, use an eyebolt for lifting aids.

4.2 Function

4.2.1 Quiescent Current Principle

The functional principle applied here is the energy-separation principle according to EN ISO 13849-2 Appendix A.2 "List of basic safety principles". The reliable condition is achieved through separation of the energy source, and thus accords with the required safety aspects, for example during power failure or EMERGENCY STOP.

4.2.3 Release Monitoring

Design mit plug:

Monitoring with ROBA®-brake-checker.

Design mit terminal box:

ROBA®-topstop® brakes are supplied as a standard product with manufacturer-side set release monitoring.

Function description:

The integrated release monitoring detects the armature disk position of either armature disk attracted (released) or dropped (closed), and emits a signal accordingly. From attracted to dropped condition, the armature disk carries out a path of approx. 0.4 mm. In energised condition, the armature disk is attracted and lies against the coil carrier. The brake is free; the power circuit for the release monitoring is closed (NO function) and emits a signal. If the electromagnet is switched off, the thrust springs press the armature disk away from the coil carrier, against the rotor. The brake has its braking torque, and the release monitoring signal is switched off. Both inspections; the signal evaluation and the condition change, must take place customer-side. This prevents possible start-up of the motor against the closed brake and the resulting damage to the brake. A reliable start to the following program steps can take place.

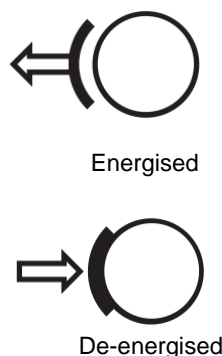

The release monitoring is equipped with a proximity switch as a standard measure. Optionally, a microswitch design is also available (see section **10.12** release monitoring)

Signal evaluation:

After each energisation or de-energisation of the brake, a signal change of the release monitoring must take place within $3 \times t_1$ ($3 \times$ connection time) and $3 \times t_2$ ($3 \times$ separation time). If this plausibility is not fulfilled, an unpermitted condition has occurred.

→ Monitoring correct signal state/edge change

WARNING Load crash possible



The brake may not have built up a braking torque.

If no signal change occurs on brake de-energisation after $3 \times t_1$, a dangerous failure may have occurred.

A machine-side malfunction message must occur in order to achieve a safe condition.

4.3 Designs

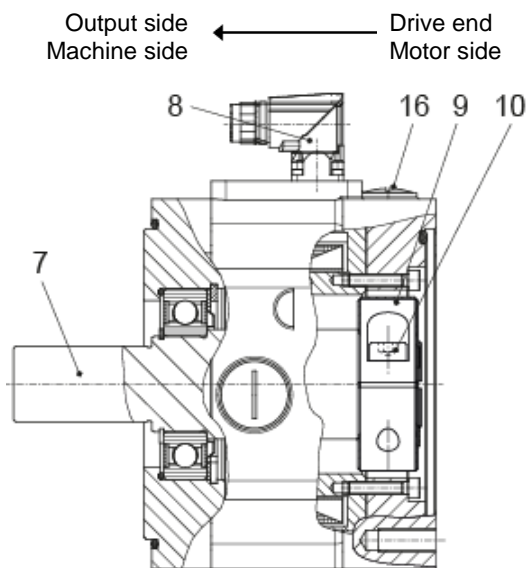

Fig. 1: Type 8990.000_._._._._

Output side Machine side ← Drive end Motor side

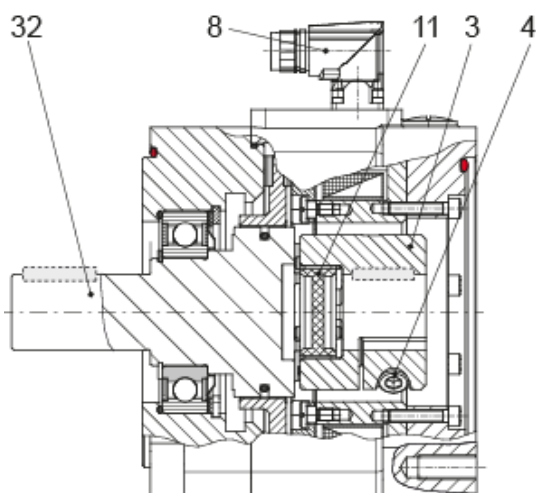

Fig. 2: Type 8990.01_._._._._

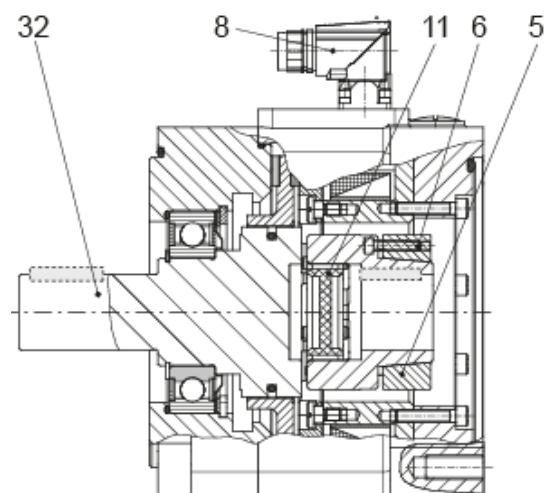

Fig 3: Type 8990.02_._._._._

Operational Instructions for ROBA®-topstop® Type 899_._._._._ Size 100 - 260

(B.899.EN)

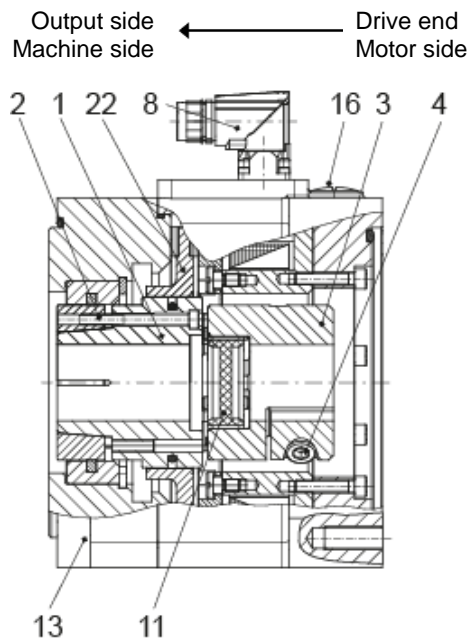

Fig. 4: Type 8990.11_._._

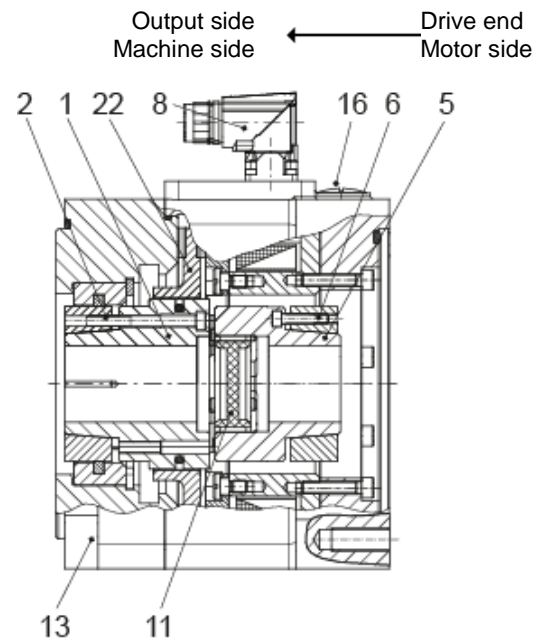

Fig. 5: Type 8990.12_._._

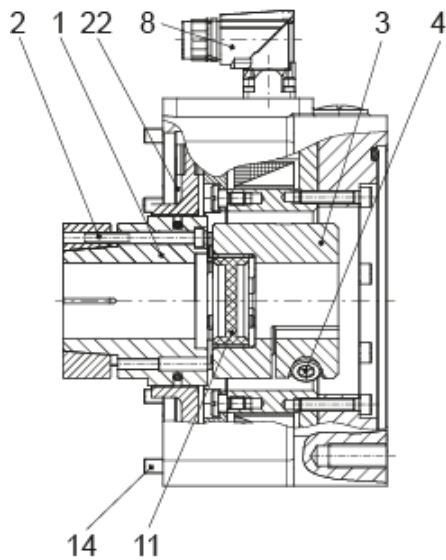

Fig. 6: Type 8991.11_._._

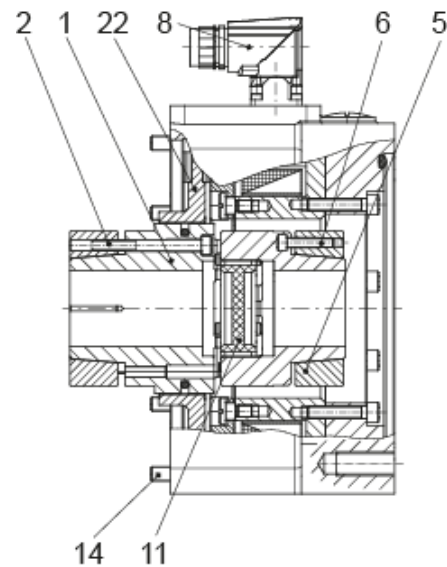

Fig. 7: Type 8991.12_._._

Operational Instructions for ROBA®-topstop® Type 899_._ _ _ _ _ Size 100 - 260

(B.899.EN)

4.4 Parts List

(Only use *mayr*® original parts)

Item	Name
1	Shrink disk hub assembly (output side)
2	Cap screw
3	Clamping hub
4	Cap screw
5	Shrink disk hub assembly (Drive end)
6	Cap screw
7	Shaft (Type 8990.000_ _)
8	Plug (standard)
9	Clamping ring
10	Cap screw
11	Elastomeric element
12	Flange housing (drive end)
13	Flange (output side)
14	Cap screw
15	Terminal box / plug (acc. design)
16	Screw plug
17	Cap screw (provided by the customer), property class 8.8
18	Cap screw (provided by the customer), property class 8.8, minimal screw-in depth 1.5 x dimension "S ₁ "
19	Type tag
20	Coil carrier
21	Armature disk
22	Rotor
23	Threaded bolt (section 10.12.3)
24	Counter nut M5 (section 10.12.3)
25	Hexagon head screw M3 x 8 (section 10.12.3)
26	Counter nut M3 (section 10.12.3)
27	Microswitch assembly for release monitoring (section 10.12.3)
28	Proximity switch assembly for release monitoring (section 10.12.2)
29	Switching bolt (section 10.12.2)
30	Cap screw M5 x 30 (section 10.12.2)
31	Cap screw M4 x 8 (section 10.12.2)
32	Shaft (Type 8990.01_ _ _ and 8990.02_ _ _)
35	Screw plug (section 15)
36	Friction flange (output side / customer-side)

Operational Instructions for ROBA®-topstop® Type 899_._ _ _ _ _ Size 100 - 260

(B.899.EN)

4.5 Dimensions and Tightening Torques

ROBA®-topstop® brake		Sizes					
		100	120	150	175	200	260
Dimension z ₂ (tolerance -0.03)		-	5.5	5.5	6	6	8
Required shaft length (brake) "l ₂ "	[mm]	-	25 – 52	30 – 60	35 – 75	35 – 75	40 – 80
Required shaft length (motor) "l ₃ "	[mm]	-	40 – 50	50 – 58	58 – 80 ¹⁾	58 – 80 ¹⁾	80 – 110 ²⁾
Installation dimension (output) "W"	[mm]	-	68	75.5	85	85	107
Installation dimension (motor) "W ₁ "	[mm]	-	36	42	52.5	52.5	52
Installation dimension (motor) "W ₂ "	[mm]	-	79	87.5	97.5	97.5	123
Installation dimension (motor) "W ₃ "	[mm]	-	16	18.5	22.5	22.5	26
Installation dimension (motor) "Y"	[mm]	-	5	6.5	10	10	10
Installation dimension (motor) "Y ₁ " (=a ₁)	[mm]	-	20	20.5	16	16	23
Installation dimension (motor) "Y ₂ "	[mm]	-	66	73	82	82	103.5
Screw thread Items 2/6		-	M5	M5	M6	M6	M8
Screw tightening torque Items 2/6	[Nm]	-	6	6	10	10	30
Screw thread Item 4		-	M6	M8	M8	M8	M12
Screw tightening torque Item 4	[Nm]	-	10	24	24	24	120
Screw thread Item 10		M5	M6	M8	M10	M10	M12
Screw tightening torque Item 10	[Nm]	8.5	17	42	83	83	143
Screw thread Item 14		M4	M5	M6	M6	M8	M10
Screw tightening torque Item 14	[Nm]	2.9	6	10	10	24	48
Screw thread Items 17/18		M6/M8 ⁷⁾	M8	M10	M12	M12	M16
Screw tightening torque Items 17/18	[Nm]	10/24 ⁷⁾	24	48	83	83	200
Rotor thickness in new condition	[mm]	7 ^{+0.05}	10.5 ^{-0.05}	11.5 ^{-0.05}	15 ^{-0.05}	15 ^{-0.05}	16 ^{-0.05}
Thread Ø "s ₁ "	[mm]	M6/M8 ⁷⁾	M8	M10	M12	M12	M16
Threaded hole depth "b" ⁵⁾	[mm]	12/15 ⁷⁾	20	24	25	28	30
Max. permitted air gap dimension X ^{5) 6)}	[mm]	0.5	0.55	0.6	0.6	0.6	0.65
Max. permitted pull-in voltage ⁶⁾ at room temperature in % of the coil nominal voltage / overexcitation voltage		80	80	80	80	80	80

1) At a shaft length of more than 60 mm, only possible with a bored elastomeric element (11), for a max. shaft diameter of 38 mm

2) At a shaft length of more than 85 mm, only possible with a bored elastomeric element (11), for a max. shaft diameter of 48 mm

3) At a shaft length of more than 85 mm, only possible with a bored elastomeric element (11), for a max. shaft diameter of 42 mm

4) Please **observe!!** Minimal screw-in depth 1.5 x dimension "s₁"

5) Dimension X is the air gap between the rotor (22) and the armature disk (21) on an energised brake (section **15**)

6) The information applies for the braking torque Standard as well as for the braking torque Increased (Type 899_._ _ _ 1_ / 899_._ _ _ 2_)

7) Dependent on the screw-on pitch circle and centering (see **5.2** Technical Data)

4.6 Further Designs

4.6.1 Shaft with Key

For a positive-locking connection (see section [8.1.2](#))

4.6.2 Hand release



The hand release is optional and must be ordered with the brake. The hand release is installed and set manufacturer-side. Only with protection IP54 possible.

The hand release is subject to wear and is not suitable for constant release.

A sufficient number of emergency releases is possible (approx. 1000x).

WARNING Load crash possible



The braking torque of the brake is nullified on actuation of the hand release.

When actuating the hand release, the axis / load must be supported.

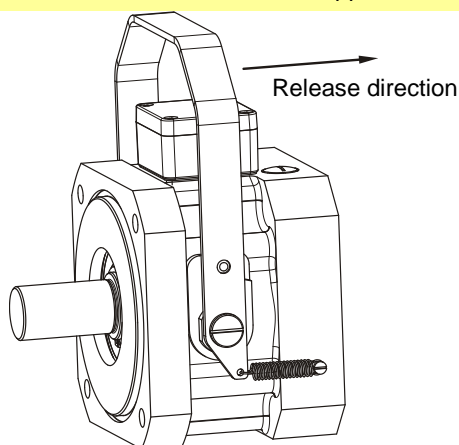

Fig. 8: Brake not released (ready for operation)

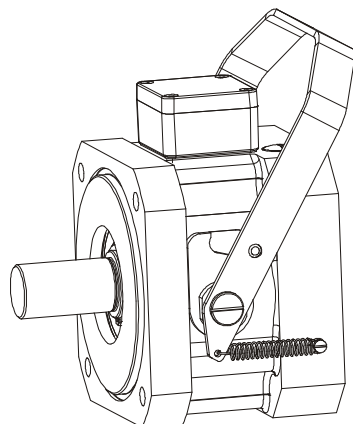

Fig. 9: Brake released (not ready for operation)

5 Technical Data

5.1 Guidelines

5.1.1 Application Conditions



The stated values are guideline values which have been determined in test facilities. It may be necessary to carry out your own tests for the intended application. When dimensioning the brakes, please remember that installation situations, braking torque fluctuations, permitted friction work, run-in behaviour and wear as well as general ambient conditions can all affect the given values. These factors should therefore be carefully assessed, and alignments made accordingly.

- ❑ Mounting dimensions and connection dimensions must be adjusted according to the size of the brake at the place of installation.
- ❑ The magnetic coils are designed for a relative duty cycle of 100%.
- ❑ Temperatures of up to 60 °C can occur on the brake housing at an ambient temperature of 40 °C.
In higher ambient temperatures, for example when mounted onto the drive motor, which can achieve temperatures of 80 °C to 100 °C during operation, the brake housing temperature will also increase. Protective measures must be undertaken customer-side against contact burns.
- ❑ The braking torque is dependent on the present run-in condition of the brake.
- ❑ The surfaces of the outer components have been phosphated manufacturer-side to form a basic corrosion protection. For brake applications outdoors where the device is subject to weather influences or extreme environmental conditions, additional protective measures, such as for example protective paint, must be provided.
- ❑ No axial backlash must be transmitted onto the brake customer-side (max. 0.05 mm).
Excessive axial backlash leads to particularly heavy wear on the rotor (22).

Attention The rotors may rust up and block in corrosive ambient conditions and/or after long periods of storage. The user is responsible for taking appropriate countermeasures.
▶ Please contact *mayr*® power transmission.

5.1.2 Ambient Temperature

–20 °C up to +40 °C

The Technical Data refer to the stated temperature range.

Attention At temperatures of around or under freezing point, condensation can strongly reduce the torque or the rotors may freeze up. The user is responsible for taking appropriate countermeasures such as heating.
▶ Please contact *mayr*® power transmission.

5.1.3 Class of Insulation F (+155 °C)

The insulation components on the magnetic coils are manufactured at least to class of insulation F (+155 °C).

5.1.4 Protection

(mechanical) IP67: When installed, dust-proof and protected against contact as well as against temporary submersion under water (depending on installation by the customer).

(electrical) IP67: Dust-proof and protected against contact as well as against temporary submersion under water (depending on installation by the customer).

The penetration of dirt from the drive end (machine side) via the shaft cannot be ruled out.

5.1.5 Noise Emissions

The ROBA®-topstop® is not noise-reduced. When the armature disk is switched, the impact pulse from the armature disk onto the coil carrier or the armature disk onto the rotor generates a switching noise which can reach approx. 90 dB(A). The brake is not suitable for use in noise-sensitive applications.

5.2 Technical Data

5.2.1 Type 8990.000 _ _

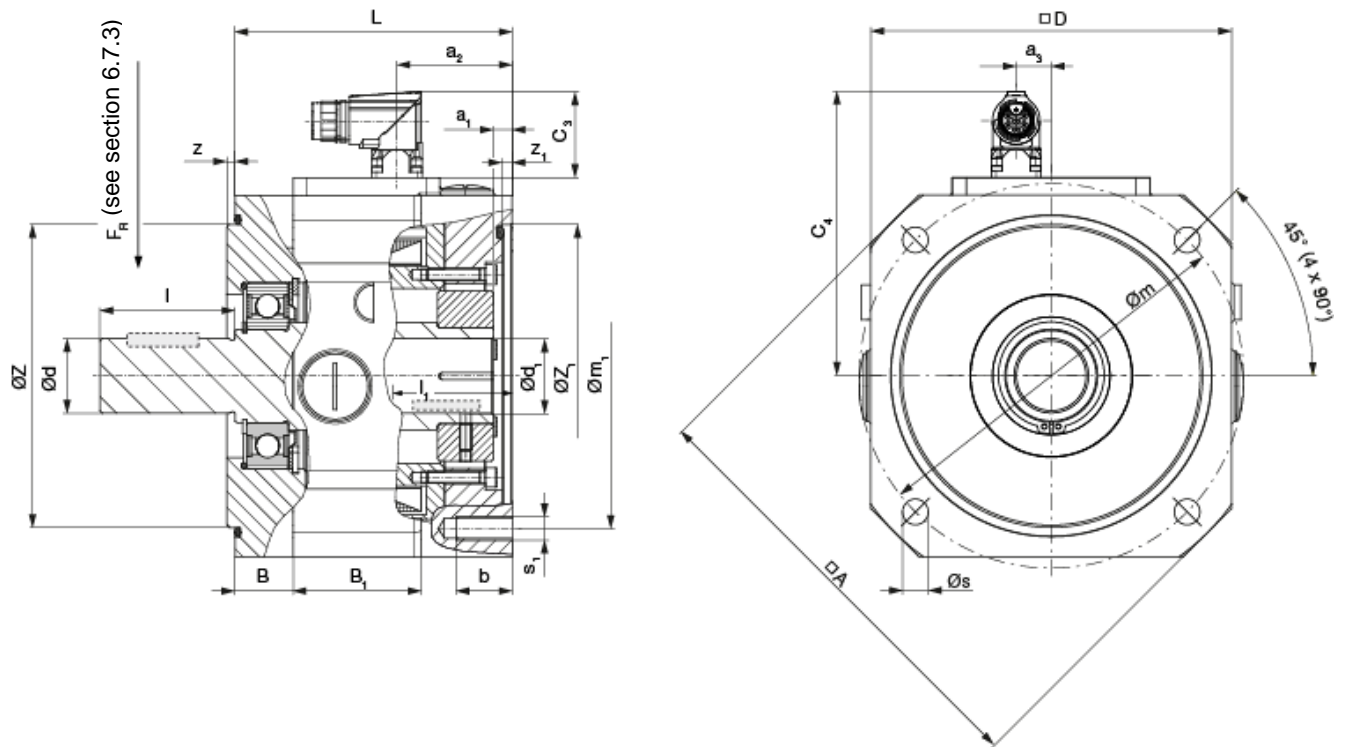

Fig. 10 Type 8990.000 _ _
 Output side: Shaft
 Motor side: Clamping hub

Operational Instructions for ROBA®-topstop® Type 899 _ _ _ _ _ Size 100 - 260

(B.899.EN)

Technical Data				Size					
				100	120	150	175	200	260
Braking torque 1)	8990.0001_	Standard	[Nm]	6	12	45	70	100	200
		-20% / +40%	[Nm]	4.8 / 8.4	9.6 / 16.8	36 / 63	56 / 98	80 / 140	160 / 280
	8990.0002_ 4)	Increased	[Nm]	12	30	90	120	160	400
-20% / +40%		[Nm]	9.6 / 16.8	24 / 42	72 / 126	96 / 168	128 / 224	320 / 560	
M _N	8990.0001_	P _N	[W]	21	31.5	44	50	60	86
		P _O 2)	[W]	66	102	128	128	148	200
	8990.0002_	P _H 3)	[W]	16	26	32	32	38	50
Electrical power	8990.0001_	P _N	[W]	21	31.5	44	50	60	86
Maximum speed	8990.000_ _	n _{max}	[rpm]	6000	5000	4000	4000	3000	3000
Weight	8990.000_ _	m	[kg]	4.75	7.5	13	20	24	60
Mass moment of inertia Rotor + hub with d _{max}	8990.000_ _	J _{R+N}	[10 ⁻⁴ kgm ²]	0.9	6.5	16	43	52	250

Dimen- sions	Size					
	100	120	150	175	200	260
A	130	160	190	232	246	345
a₁	4	5	8	10	10	10
a₂	24	41.5	49.5	58.5	59	78
a₃	15	15	15	15	15	15
B	15	20	25	19.5	20	25
B₁	42	52	55	90	71	92
b	12	20	24	25	28	30
C₃	37	37	37	37	37	37
C₄	87	108	122	125	142	169
D	100	130	155	176	194	264
L	80	104	119	138.5	138.5	185
Shaft Ø d _{k6} x l	14 x 30	19 x 40	24 x 50	35 x 79	32 x 58	48 x 82
	19 x 40	24 x 50	32 x 58	-	38 x 80	42 x 110
	-	-	-	-	-	48 x 110
	-	-	-	-	-	55 x 110
Bores⁵⁾ Ø d ₁ ^{F7} x l ₁	14 x 45	19 x 55	24 x 68	35 x 90	32 x 90	42 x 110
	19 x 45	24 x 55	32 x 68	-	38 x 90	48 x 110
	-	-	-	-	-	55 x 110
m	100/ 115	130	165	200	215	300
m₁	100/ 115	130 (115*)	165	200	215	300
s	7/9	9	11	13.5	13.5	18
s₁	4 x M6 4 x M8	4 x M8	4 x M10	4 x M12	4 x M12	4 x M16
SW	4	5	6	8	8	10
Z_{j6}	80	110	130	114.3	180	250
	95	95	110	-	130	-
Z₁^{F8} (x z₁)	80	110x 4	130x 4,5	114.3	180x 5	250
	95	95x5	110x 5	-	130x 6	-
z	3	3	3.5	3.5	4	5
z₁	4	-	-	10	-	10

Preferred Bore		d ₁	Size					
			100	120	150	175	200	260
Frictionally- locking trans- mittable tor- ques (clamp- ing hub mo- tor-side) Suit- able for F7/k6	T _R [Nm]	Ø 14	30	-	-	-	-	-
		Ø 19	40	64	-	-	-	-
		Ø 24	-	81	150	-	-	-
		Ø 32	-	-	199	-	-	-
		Ø 35	-	-	-	215	-	-
		Ø 38	-	-	-	-	-	-
		Ø 42	-	-	-	-	545	545
		Ø 48	-	-	-	-	670	670
Ø 55	-	-	-	-	845	845		

Correlation of bore diameters d₁, dependent on respec-
tive transmittable torques (without key).

The transmittable torques for the clamping connection al-
low for the max. tolerance backlash on a solid shaft: Tol-
erance k6 / bore (d₁): tolerance F7. If the tolerance back-
lash is larger, the torque decreases.

1) Braking torque tolerance: -20 % / +40 %

2) Coil capacity on overexcitation

3) Coil capacity at holding voltage

4) Braking torque Increased only with overexcitation
(see **7.4.1.3**)

5) The transmittable torques in bore d₁ are dependent
on the diameter.

*) Optionally available with pitch circle m₁ = 115

We reserve the right to make dimensional and con-
structional alterations.

Operational Instructions for ROBA®-topstop® Type 899 Size 100 - 260

(B.899.EN)

5.2.2 Type 8990.0

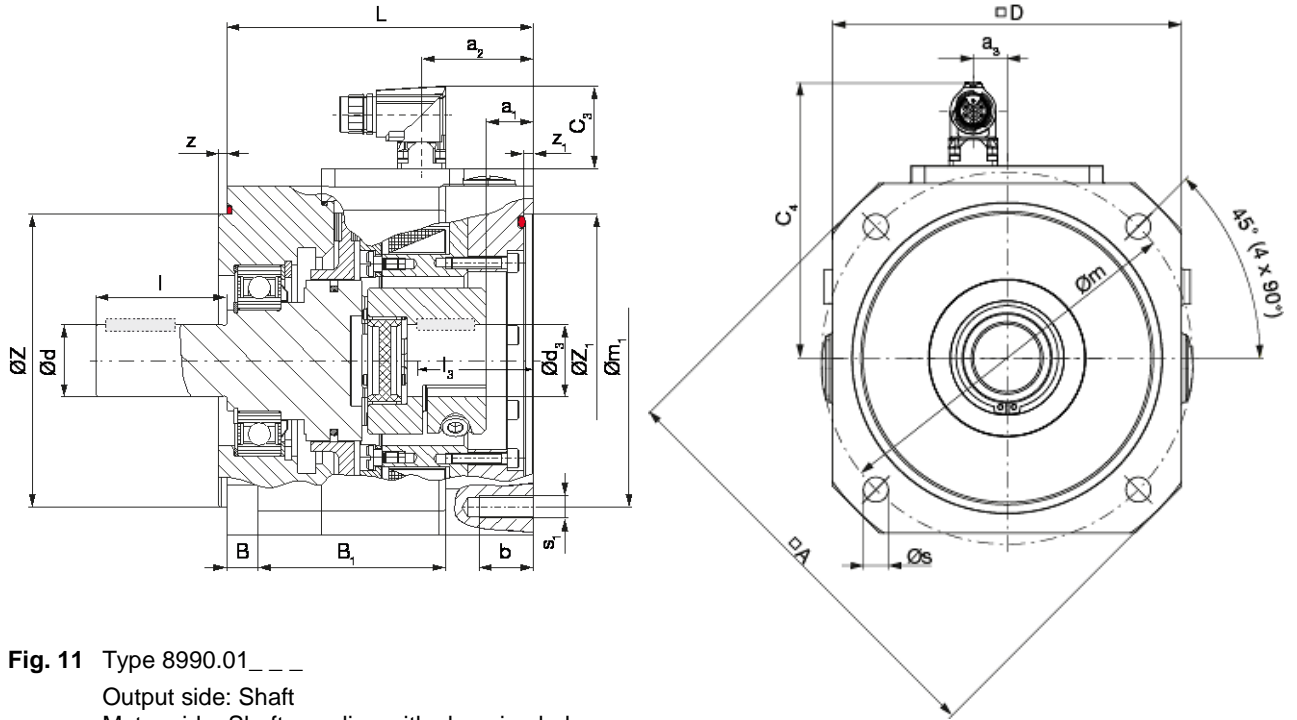

Fig. 11 Type 8990.01
Output side: Shaft
Motor side: Shaft coupling with clamping hub

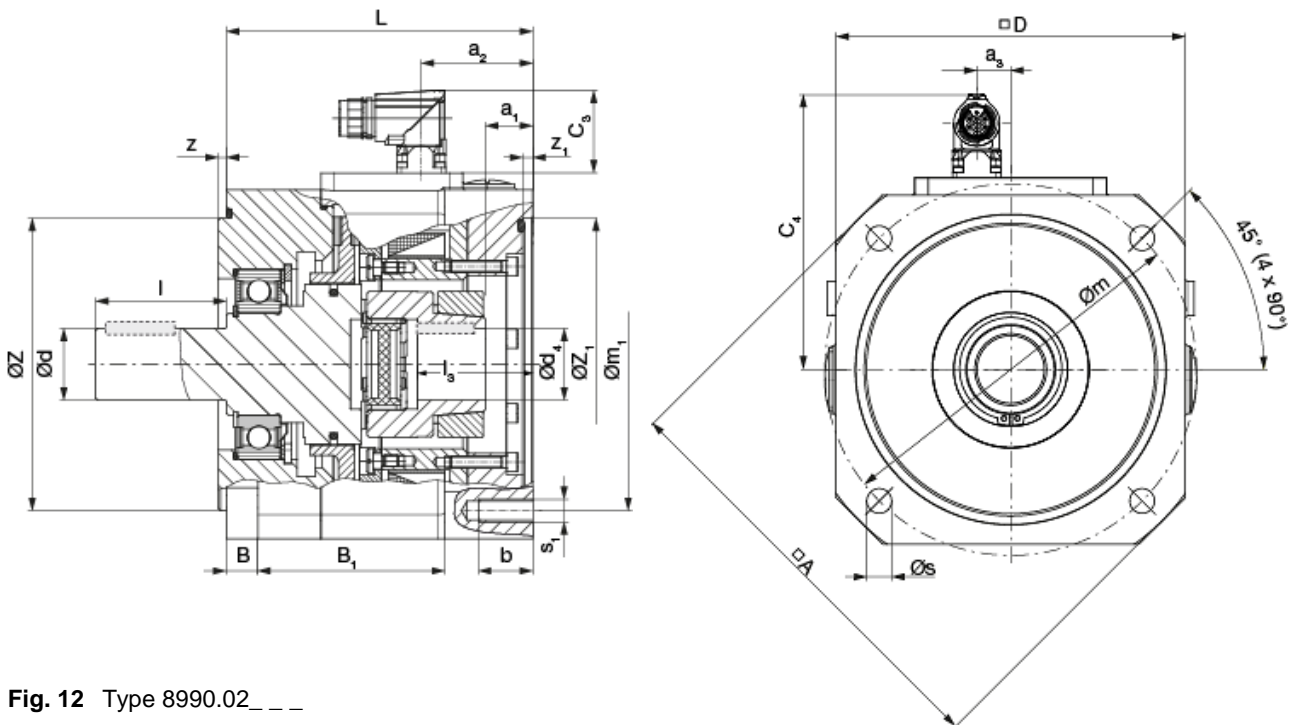

Fig. 12 Type 8990.02
Output side: Shaft
Motor side: Shaft coupling with shrink disk hub

Operational Instructions for ROBA®-topstop® Type 899 Size 100 - 260

(B.899.EN)

Technical Data				Size				
				120	150	175	200	260
Braking torque ¹⁾	8990.0__1__	Standard	[Nm]	12	45	70	100	200
		-20% / +40%	[Nm]	9.6 / 16.8	36 / 63	56 / 98	80 / 140	160 / 280
M _N	8990.0__2__ ⁴⁾	Increased	[Nm]	30	90	120	160	400
		-20% / +40%	[Nm]	24 / 42	72 / 126	96 / 168	128 / 224	320 / 560
Electrical power	8990.0__1__	P _N	[W]	31.5	44	50	60	86
		P _O ²⁾	[W]	102	128	128	148	200
		P _H ³⁾	[W]	26	32	32	38	50
Maximum speed	8990.0_____	n _{max}	[rpm]	5000	4000	4000	3000	3000

Size of Flexible Coupling ⁵⁾ (ROBA®-ES)			[-]	24	28	38	38	42	48	
Nominal and maximum torques, flexible coupling ⁵⁾	8990.0_3__ 92 Sh A	T _{KN} / T _{Kmax}	[Nm]	35 / 70	95 / 190	190 / 380	190 / 380	265 / 530	310 / 620	
			8990.0_2__ 98 Sh A	[Nm]	60 / 120	160 / 320	325 / 650	325 / 650	450 / 900	525 / 1050
			8990.0_1__ 64 Sh D	[Nm]	75 / 150	200 / 400	405 / 810	405 / 810	560 / 1120	655 / 1310
Weight	8990.0_____	m	[kg]	8.5	15	23	28	45	60	
Mass moment of inertia Rotor + hub with d _{max}	8990.01_____	J _{R+N}	[10 ⁻⁴ kgm ²]	7.5	18.5	60	67	137	235	
			8990.02_____	[kgm ²]	8.5	21.5	70	77	151	250

Dimensions	Size				
	120	150	175	200	260
A ⁷⁾	160	190	232	246	345
a ₁	18.5	20.5	16	16	23
a ₂	41.5	49.5	58.5	59	78
a ₃	15	15	15	15	15
B	12	14	20	20	25
B1	76	83	90	92.5	92
b	20	24	25	30	30
C ₃	37	37	37	37	37
C ₄	108	122	125	142	169
D ⁷⁾	130	155	176	194	264
L	120	136	160	160	185
Shaft Ø d _{k6} x l	19 x 40	24 x 50	35 x 79	32 x 58	48 x 82
	24 x 50	32 x 58	-	38 x 80	42 x 110
	-	-	-	-	48 x 110
	-	-	-	-	55 x 110
Bores Ø d ₃ ^{F7} ⁶⁾ Ø d ₄ ^{H7}	15-28	19-35	20-45*	20-45*	35-55*
	15-28	19-38	20-45*	20-45*	35-60*
Required shaft length l ₃	40-50	50-58	58-80*	58-80*	80 - 110*
m ⁷⁾	130	165	200	215	300
m1	130 (115**)	165	200	215	300
s ⁷⁾	9	11	13.5	13.5	18
s ₁	4xM8	4xM10	4xM12	4xM12	4xM16
SW	5	6	6	6	10

Dimensions	Size				
	120	150	175	200	260
SW ₁	4	4	5	5	6
Z ₁₆	110	130	114.3	180	250
	95	110	-	130	-
Z ₁ ^{F8} (x z ₁)	110x4	130x4,5	114.3	180x5	250
	95x5	110x5	-	130x6	-
z	3	3.5	3.5	4	5
z ₁	-	-	10	-	10

- 1) Braking torque tolerance: -20 % / +40 %
- 2) Coil capacity on overexcitation
- 3) Coil capacity at holding voltage
- 4) Braking torque Increased only with overexcitation (see **7.4.1.3**)
- 5) For further information on flexible coupling e.g. angular misalignments, spring stiffness or temperature resistance please see ROBA®-ES catalogue [K.940.V_____](#)
- 6) The transmittable torques in bores d₃ and d₄ are dependent on the diameter, see tables "Preferred Bores" **5.2.3**.
- 7) See Dimensions Fig. on the right, Section **5.2.1**.
*) - Sizes 175 and 200: At a shaft length of more than 60 mm, only possible with a bored elastomeric element (max. through hole Ø38 mm)
- Size 260: At a shaft length of more than 85 mm, only possible with a bored elastomeric element (max. through hole Ø48 mm)
**) Optionally available with pitch circle m1 = 115

We reserve the right to make dimensional and constructional alterations.

5.2.3 Type 8990.1

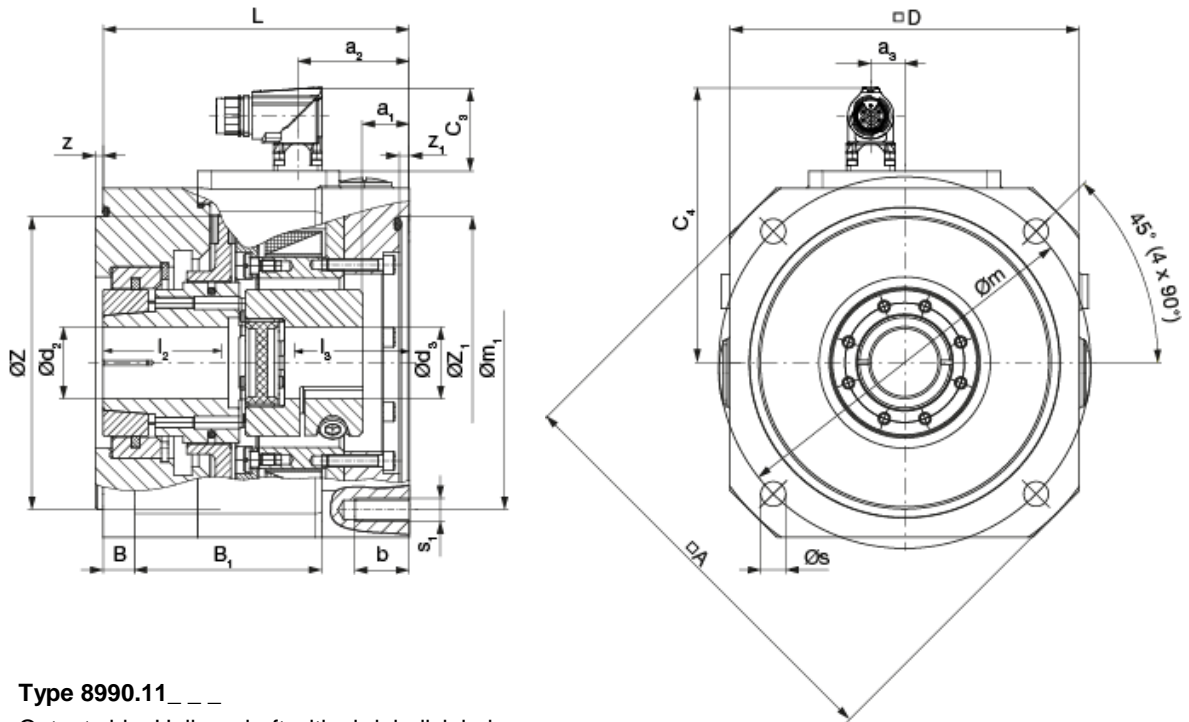

Fig. 13 Type 8990.11
 Output side: Hollow shaft with shrink disk hub
 Motor side: Shaft coupling with clamping hub

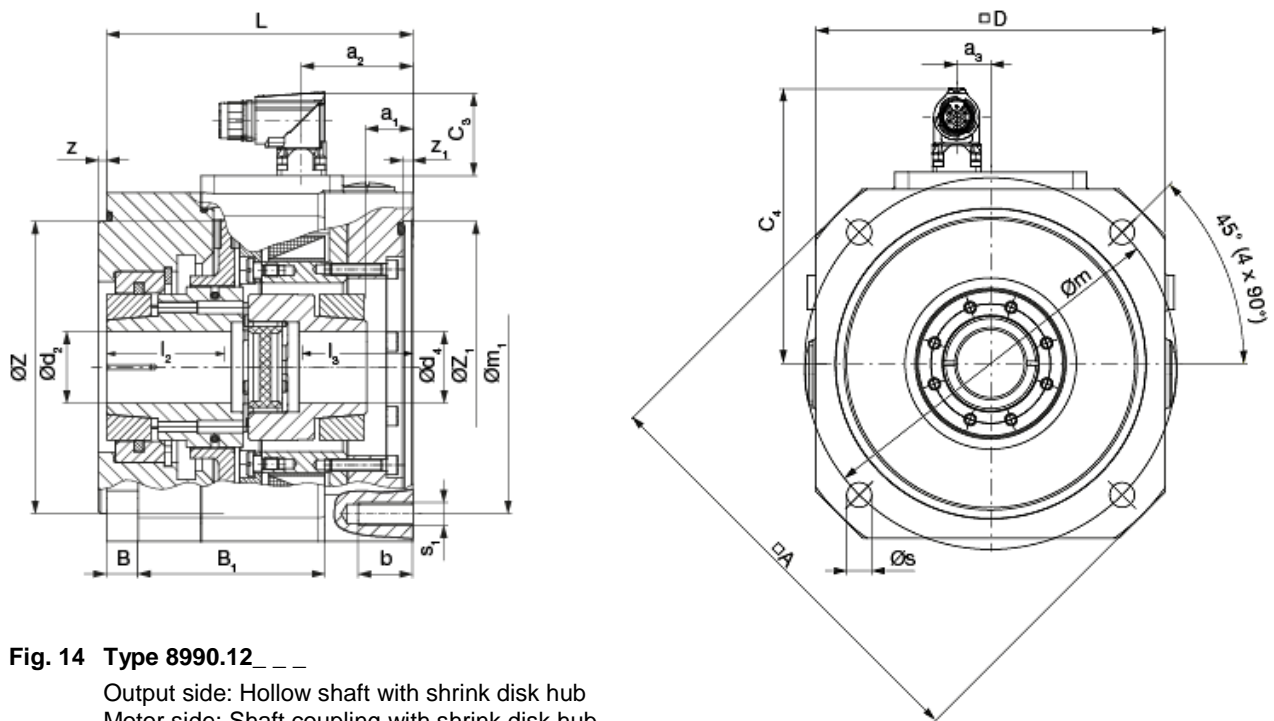

Fig. 14 Type 8990.12
 Output side: Hollow shaft with shrink disk hub
 Motor side: Shaft coupling with shrink disk hub

Operational Instructions for ROBA®-topstop® Type 899_._._._._ Size 100 - 260

(B.899.EN)

Technical Data				Size				
				120	150	175	200	260
Braking torque ¹⁾	8990.1_._1_	Standard	[Nm]	12	45	70	100	200
		-20% / +40%	[Nm]	9.6 / 16.8	36 / 63	56 / 98	80 / 140	160 / 280
M _N	8990.1_._2_ ⁴⁾	Increased	[Nm]	30	90	120	160	400
		-20% / +40%	[Nm]	24 / 42	72 / 126	96 / 168	128 / 224	320 / 560
Electrical power	8990.1_._1_	P _N	[W]	31.5	44	50	60	86
		P _O ²⁾	[W]	102	128	128	148	200
		P _H ³⁾	[W]	26	32	32	38	50
Maximum speed	8990.1_._1_	n _{max}	[rpm]	5000	4000	4000	3000	3000

Size of Flexible Coupling ⁵⁾ (ROBA®-ES)			[-]	24	28	38	38	42	48
Nominal and maximum torques, flexible coupling ⁵⁾	8990.1_3_ 92 Sh A	T _{KN} / T _{Kmax}	[Nm]	35 / 70	95 / 190	190 / 380	190 / 380	265 / 530	310 / 620
	8990.1_2_ 98 Sh A	T _{KN} / T _{Kmax}	[Nm]	60 / 120	160 / 320	325 / 650	325 / 650	450 / 900	525 / 1050
	8990.1_1_ 64 Sh D	T _{KN} / T _{Kmax}	[Nm]	75 / 150	200 / 400	405 / 810	405 / 810	560 / 1120	655 / 1310
Weight	8990.1_._._.	m	[kg]	7.5	14	23	27	45	60
Mass moment of inertia Rotor + hub with d _{max}	8990.11_._.	J _{R+N}	[10 ⁻⁴ kgm ²]	7.5	18.5	60	67	137	235
	8990.12_._.		8.5	21.5	70	77	151	250	

Dimensions	Size					
	120	150	175	200	260	
A	160	190	232	246	345	
a ₁	18	20.5	16	16	23	
a ₂	41.5	49.5	58.5	59	78	
a ₃	15	15	15	15	15	
B	12	14	20	20	25	
B1	76	83	90	92.5	92	
b	20	24	25	28	30	
C	58	58	58	58	75	
C ₃	37	37	37	37	37	
C ₄	108	122	125	142	169	
D	130	155	176	194	264	
L ₂	120	136	160	160	185	
Bores ⁶⁾	∅ d ₂ H ₆	15-28	19-38	20-45	20-45	35-60
	∅ d ₃ F ₇	15-28	19-35	20-45 *	20-45 *	35-55 *
	∅ d ₄ H ₇	15-28	19-38	20-45 *	20-45 *	35-60 *
Required shaft length	l ₂	25-52	30-60	35-75	35-75	40-80
	l ₃	40-50	50-58	58-80 *	58-80 *	80-110 *
m ⁷⁾	130	165	200	215	300	
m1	130 (115**)	165	200	215	300	
s ⁷⁾	9	11	13.5	13.5	18	
s ₁	4xM8	4xM10	4xM12	4xM12	4xM16	
SW	5	6	6	6	10	
SW ₁	4	4	5	5	6	
Z _{j6}	110	130	114.3	180	250	
	95	110	-	130	-	
Z ₁ ^{F8} (x z ₁)	110x4	130x4,5	114.3	180x5	250	
	95x5	110x5	-	130x6	-	
z	3	3.5	3.5	4	5	
z ₁	-	-	10	-	10	

Operational Instructions for ROBA®-topstop® Type 899 Size 100 - 260

(B.899.EN)

Preferred Bore		d ₂ / d ₄	Size					
			120	150	175	200	260	
Frictionally- locking trans- mittable tor- ques shrink disk hub	T _R [Nm]	Ø 15	56	-	-	-	-	
		Ø 16	62	-	-	-	-	
		Ø 19	81	141	-	-	-	
		Ø 20	87	153	197	197	-	
		Ø 22	100	177	228	228	-	
		Ø 24	120	203	261	261	-	
		Ø 25	125	216	279	279	-	
		Ø 28	135	256	332	332	-	
		Ø 30	-	282	368	368	-	
		Ø 32	-	308	405	405	-	
		Ø 35	-	343	460	460	450	
		Ø 38	-	373	513	513	500	
		Suitable for H6/k6	Ø 40	-	-	547	547	600
			Ø 42	-	-	577	577	720
			Ø 45	-	-	617	617	850
			Ø 48	-	-	-	-	1000
			Ø 50	-	-	-	-	1180
			Ø 52	-	-	-	-	1270
Ø 55	-		-	-	-	1353		
Ø 58	-		-	-	-	1428		
Ø 60	-	-	-	-	1471			

The transmittable torques for the clamping connection allow for the max. tolerance backlash on a:

- solid shaft: Tolerance k6 / bores Ø d₂ and Ø d₄: tolerance H6,
- solid shaft: Tolerance k6 / bore Ø d₃: tolerance F7.

If the tolerance backlash is larger, the torque decreases.

Preferred Bore		d ₃	Size					
			120	150	175	200	260	
Frictionally- locking trans- mittable tor- ques clamp- ing hub	T _R [Nm]	Ø 15	34	-	-	-	-	
		Ø 16	36	-	-	-	-	
		Ø 19	43	79	-	-	-	
		Ø 20	45	83	83	83	-	
		Ø 22	50	91	91	91	-	
		Ø 24	54	100	100	100	-	
		Ø 25	57	104	104	104	-	
		Ø 28	63	116	116	116	-	
		Ø 30	-	124	124	124	-	
		Ø 32	-	133	133	133	-	
		Ø 35	-	145	145	145	350	
		Ø 38	-	-	158	158	390	
		Valid for F7/k6	Ø 40	-	-	166	166	420
			Ø 42	-	-	174	174	455
			Ø 45	-	-	187	187	505
			Ø 48	-	-	-	-	560
			Ø 50	-	-	-	-	600
			Ø 52	-	-	-	-	640
Ø 55	-		-	-	-	705		

- 1) Braking torque tolerance -20 % / +40 %
- 2) Coil capacity on overexcitation
- 3) Coil capacity at holding voltage
- 4) Braking torque Increased only with overexcitation (see 7.4.1.3)
- 5) For further information on flexible coupling e.g. angle misalignments, spring stiffness or temperature resistance please see ROBA®-ES catalogue [K.940.V__](#)
- 6) The transmittable torques in bores d₂, d₃ and d₄ are dependent on the diameter.

- *) - Sizes 175 and 200: At a shaft length of more than 60 mm, only possible with a bored elastomeric element (max. through hole Ø38 mm)
- Size 260: At a shaft length of more than 85 mm, only possible with a bored elastomeric element (max. through hole Ø48 mm)

***) Optionally available with pitch circle m1 = 115

We reserve the right to make dimensional and constructional alterations.

Operational Instructions for ROBA®-topstop® Type 899 Size 100 - 260

(B.899.EN)

5.2.4 Type 8991.1

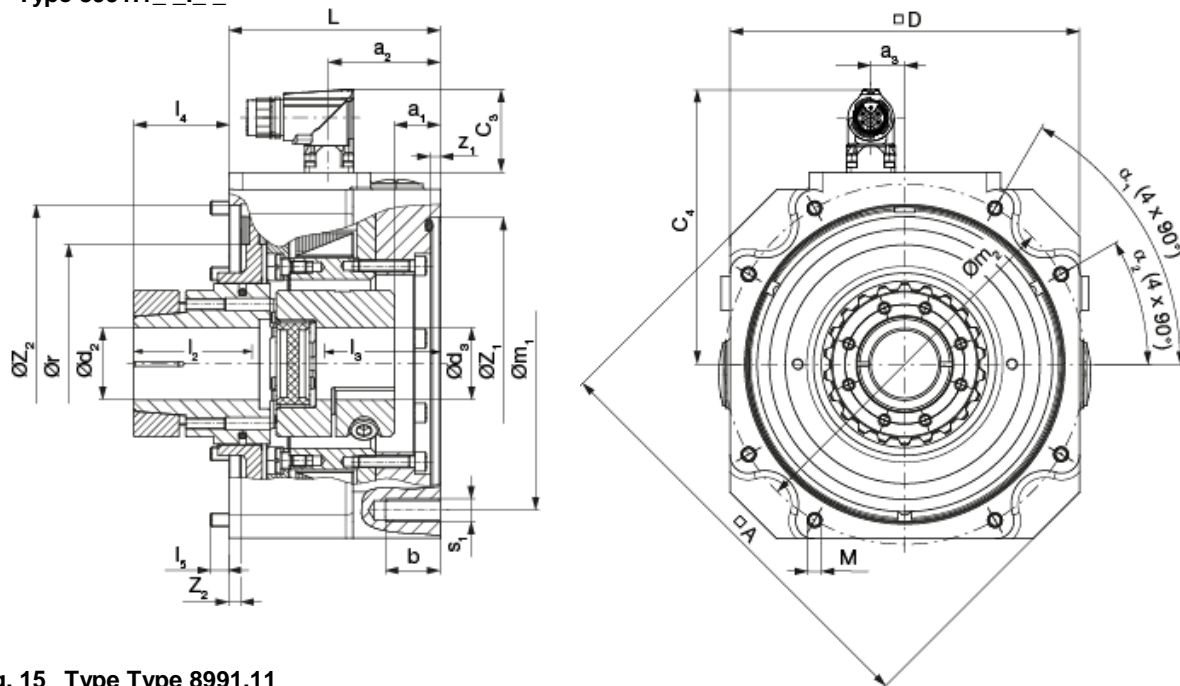

Fig. 15 Type Type 8991.11

Output side: without flange, Hollow shaft with shrink disk hub
Motor side: Shaft coupling with clamping hub

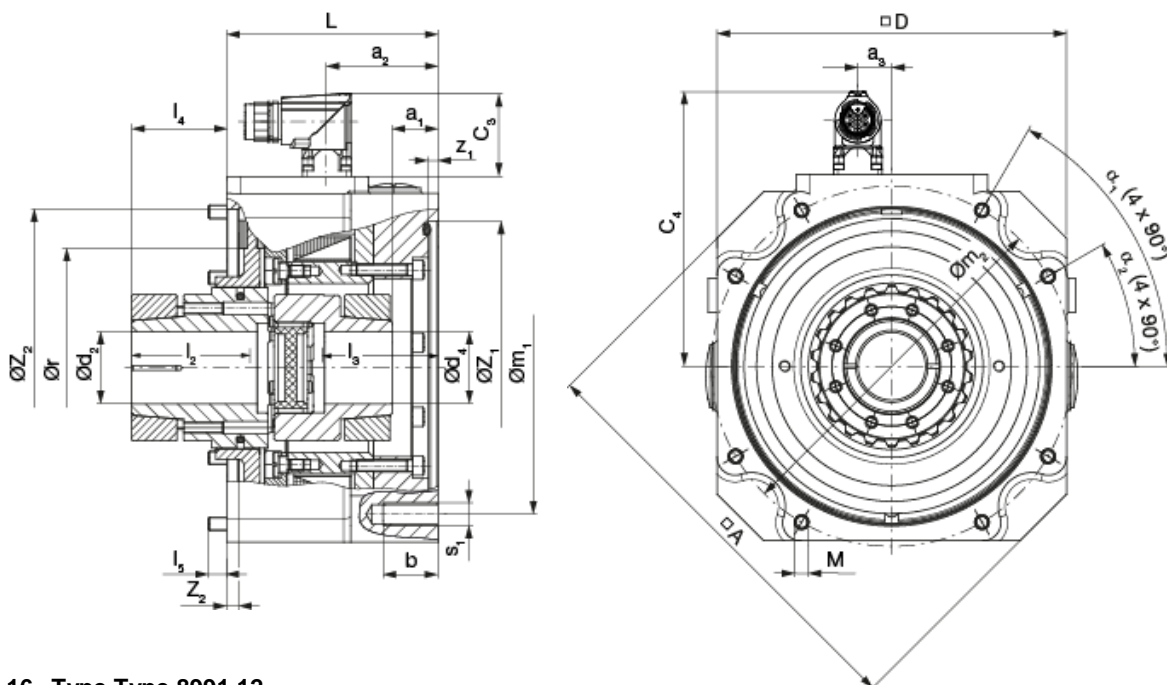

Fig. 16 Type Type 8991.12

Output side: Hollow shaft with shrink disk hub
Motor side: Shaft coupling with shrink disk hub

Operational Instructions for ROBA®-topstop® Type 899_._._._._ Size 100 - 260

(B.899.EN)

Technical Data				Size				
				120	150	175	200	260
Braking torque ¹⁾	8991.1_._1_	Standard	[Nm]	12	45	70	100	200
		-20% / +40%	[Nm]	9.6 / 16.8	36 / 63	56 / 98	80 / 140	160 / 280
M _N	8991.1_._2_ ⁴⁾	Increased	[Nm]	30	90	120	160	400
		-20% / +40%	[Nm]	24 / 42	72 / 126	96 / 168	128 / 224	320 / 560
Electrical power	8991.1_._1_	P _N	[W]	31.5	44	50	60	86
		P _O ²⁾	[W]	102	128	128	148	200
		P _H ³⁾	[W]	26	32	32	38	50
Maximum speed	8991.1_._1_	n _{max}	[rpm]	5000	4000	4000	3000	3000

Size of Flexible Coupling ⁵⁾ (ROBA®-ES)			[-]	24	28	38	38	42	48
Nominal and maximum torques, flexible coupling ⁵⁾	8991.1_3_ 92 Sh A	T _{KN} / T _{Kmax}	[Nm]	35 / 70	95 / 190	190 / 380	190 / 380	265 / 530	310 / 620
	8991.1_2_ 98 Sh A	T _{KN} / T _{Kmax}	[Nm]	60 / 120	160 / 320	325 / 650	325 / 650	450 / 900	525 / 1050
	8991.1_1_ 64 Sh D	T _{KN} / T _{Kmax}	[Nm]	75 / 150	200 / 400	405 / 810	405 / 810	560 / 1120	655 / 1310
Weight	8991.1_._._	m	[kg]	4.5	8.5	14	16	27	35
Mass moment of inertia Rotor + hub with d _{max}	8991.11_._	J _{R+N}	[10 ⁻⁴ kgm ²]	7.5	18.5	60	67	137	235
	8991.12_._		8.5	21.5	70	77	151	250	

Dimensions	Size					
	120	150	175	200	260	
A	160	190	232	246	345	
a ₁	18	20.5	16	16	23	
a ₂	41.5	49.5	58.5	59	78	
a ₃	15	15	15	15	15	
b	20	24	25	28	30	
C ₃	37	37	37	37	37	
C ₄	108	122	125	142	169	
D	130	155	176	194	264	
L ₃	84	94	107.5	107.5	133	
∅ d ₂ ^{H6}	15-28	19-38	20-45	20-45	35-60	
Bores ⁶⁾ ∅ d ₃ ^{F7}	15-28	19-35	20-45*	20-45*	35-55*	
∅ d ₄ ^{H7}	15-28	19-38	20-45*	20-45*	35-60*	
Required shaft length	l ₂	25-52	30-60	35-75	35-75	40-80
	l ₃	40-50	50-58	58-80*	58-80*	80-110*
l ₄	36	42	52.5	52.5	52	
l ₅	7	8	9.3	11.5	18	
M	8xM5	8xM6	8xM6	8xM8	8xM10	
m1	130 (115**)	165	200	215	300	
m2	135	160	185	208	280	
r	83	106	135	140	195	
s ₁	4xM8	4xM10	4xM12	4xM12	4xM16	
SW	5	6	6	6	10	
SW ₁	4	4	5	5	6	
SW ₂	4	5	5	6	8	
Z1 ^{F8}	110x4	130x4,5	114.3	180x5	250	
	95x5	110x5	-	130x6	-	
Z2 ^{H7}	111	141	170	186	256	
z ₁	-	-	10	-	10	
Z2-0,03	5.5	5.5	6	6	8	

Dimensions	Size				
	120	150	175	200	260
α ₁	30°	31°	30°	30°	30°
α ₂	60°	59°	60°	60°	60°

Preferred Bore	d ₂ / d ₄	Size				
		120	150	175	200	260
Frictionally-locking transmittable torques shrink disk hub	∅ 15	56	-	-	-	-
	∅ 16	62	-	-	-	-
	∅ 19	81	141	-	-	-
	∅ 20	87	153	197	197	-
	∅ 22	100	177	228	228	-
	∅ 24	120	203	261	261	-
	∅ 25	125	216	279	279	-
	∅ 28	135	256	332	332	-
	∅ 30	-	282	368	368	-
	∅ 32	-	308	405	405	-
	∅ 35	-	343	460	460	450
	∅ 38	-	373	513	513	500
	∅ 40	-	-	547	547	600
	∅ 42	-	-	577	577	720
Suitable for H6/k6	∅ 45	-	-	617	617	850
	∅ 48	-	-	-	-	1000
	∅ 50	-	-	-	-	1180
	∅ 52	-	-	-	-	1270
	∅ 55	-	-	-	-	1353
	∅ 58	-	-	-	-	1428
	∅ 60	-	-	-	-	1471

Operational Instructions for ROBA®-topstop® Type 899_._._._._ Size 100 - 260

(B.899.EN)

The transmittable torques for the clamping connection allow for the max. tolerance backlash on a:

- solid shaft: Tolerance k6 / bores $\varnothing d_2$ and $\varnothing d_4$: tolerance H6
- solid shaft: Tolerance k6 / bore $\varnothing d_3$: tolerance F7.

If the tolerance backlash is larger, the torque decreases.

Preferred Bore	d_3	Size				
		120	150	175	200	260
Frictionally-locking transmittable torques clamping hub	$\varnothing 15$	34	-	-	-	-
	$\varnothing 16$	36	-	-	-	-
	$\varnothing 19$	43	79	-	-	-
	$\varnothing 20$	45	83	83	83	-
	$\varnothing 22$	50	91	91	91	-
	$\varnothing 24$	54	100	100	100	-
	$\varnothing 25$	57	104	104	104	-
	$\varnothing 28$	63	116	116	116	-
	$\varnothing 30$	-	124	124	124	-
	$\varnothing 32$	-	133	133	133	-
	$\varnothing 35$	-	145	145	145	350
	$\varnothing 38$	-	-	158	158	390
	$\varnothing 40$	-	-	166	166	420
	$\varnothing 42$	-	-	174	174	455
	$\varnothing 45$	-	-	187	187	505
	$\varnothing 48$	-	-	-	-	560
$\varnothing 50$	-	-	-	-	600	
$\varnothing 52$	-	-	-	-	640	
$\varnothing 55$	-	-	-	-	705	

- 1) Braking torque tolerance -20 % / +40 %
 - 2) Coil capacity on overexcitation
 - 3) Coil capacity at holding voltage
 - 4) Braking torque Increased only with overexcitation (see 7.4.1.3)
 - 5) For further information on flexible coupling e.g. angle misalignments, spring stiffness or temperature resistance please see ROBA®-ES catalogue [K.940.V_._.](#)
 - 6) The transmittable torques in bores d_2 , d_3 and d_4 are dependent on the diameter.
 - 7) Maximum bore in flange (customer-side) at least 4 mm smaller than $\varnothing r$
- *) - Sizes 175 and 200: At a shaft length of more than 60 mm, only possible with a bored elastomeric element (max. through hole $\varnothing 38$ mm)
 - Size 260: At a shaft length of more than 85 mm, only possible with a bored elastomeric element (max. through hole $\varnothing 48$ mm)
- ***) Optionally available with pitch circle $m1 = 115$

We reserve the right to make dimensional and constructional alterations.

5.2.5 Dimensions with terminal box

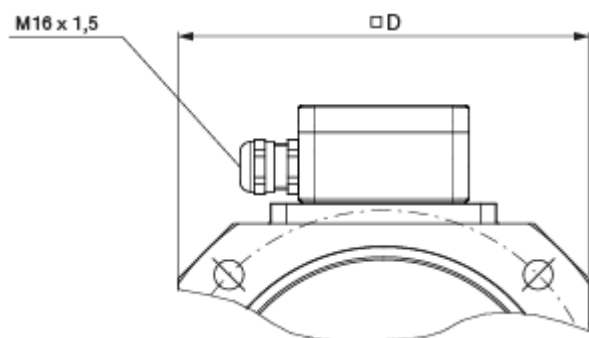
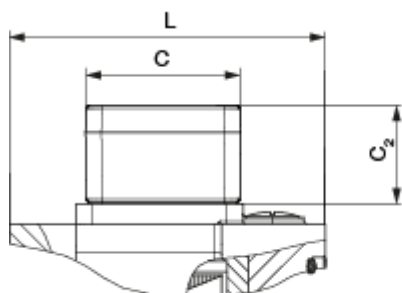

Dimensions	Size				
	120	150	175	200	260
C	58	58	58	58	75
C₂	37	37	37	37	56
D	126	155	176	194	264

5.3 Switching Times

The switching times are only valid for the stated braking torque values and can only be achieved using the respective correct electrical wiring. This also refers to the protection circuit for brake control and the response delay times of all control components.

According to Directive VDI 2241, the switching times are measured at a sliding speed of 1 m/s with reference to a mean friction radius. The brake switching times are influenced by the temperature, by the air gap between the armature disk and the coil carrier, which depends on the wear status of the linings, and by the type of voltage-limiting components.

The values stated in the table are mean values which refer to the nominal air gap and the nominal torque on a warm brake.

Typical switching time tolerances are ±20 %.

Please Observe:

Wear on the rotor increases the air gap. The separation time t_2 (release) increases by a factor of 2 at the end of the pull-in distance (max. possible air gap).

Please Observe: DC-side switching

When measuring the DC-side switching times (t_{11} – time), the inductive switch-off voltage peaks are according to VDE 0580 limited to values smaller than 1200 volts. If other voltage-limiting components are installed, this switching time t_{11} and therefore also switching time t_1 increase.

Switching times Type 899_._._._1_, brake operation with braking torque Standard (without overexcitation)

Switching Times			Size					
Type 899_._._._1_			100	120	150	175	200	260
Braking torque		[Nm]	6	12	45	70	100	200
Switching								
Connection time (close)	DC	t_1 [ms]	65	55	80	85	90	200
	AC	t_1 [ms]	350	300	400	450	600	800
Response delay on connection	DC	t_{11} [ms]	50	40	50	50	55	75
	AC	t_{11} [ms]	300	250	350	400	500	650
Separation time (release)		t_2 [ms]	70	80	150	150	200	250

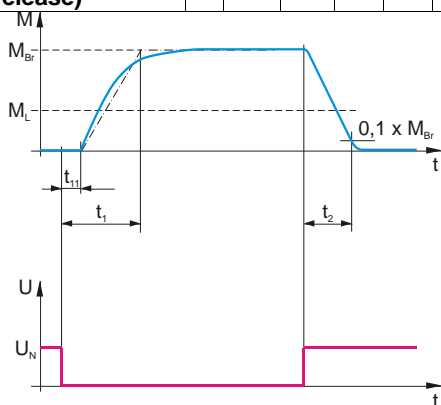
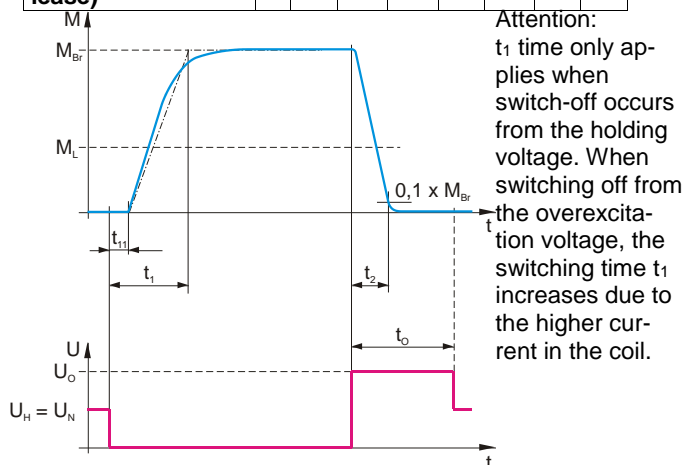

Diagram 1:
Switching times Type 899_._._._1_, brake operation with coil nominal voltage

Switching times Type 899_._._._2_, brake operation with braking torque Increased (with overexcitation)

Switching Times			Size					
Type 899_._._._2_			100	120	150	175	200	260
Braking torque		[Nm]	12	30	90	400	160	400
Switching								
Connection time (close)	DC	t_1 [ms]	40	40	50	55	60	120
	AC	t_1 [ms]	200	160	250	270	300	400
Response delay on connection	DC	t_{11} [ms]	25	20	25	25	30	35
	AC	t_{11} [ms]	175	125	200	200	250	300
Separation time (release)		t_2 [ms]	60	60	100	100	170	200



Attention:
 t_1 time only applies when switch-off occurs from the holding voltage. When switching off from the overexcitation voltage, the switching time t_1 increases due to the higher current in the coil.

Diagram 2:
Switching times Type 899_._._._2_, brake operation with overexcitation voltage

Keys

M_{Br} = Braking torque
 M_L = Load torque

t_1 = Connection time
 t_{11} = Response delay on connection

t_2 = Separation time
 t_o = Overexcitation time

U_H = Holding voltage
 U_N = Coil nominal voltage

U_o = Overexcitation voltage



On brake operation with overexcitation voltage, at least 2.5 times the brake separation time t_2 must be selected as overexcitation time t_o : $t_o \geq 2.5 \times t_2$.

It is possible to reduce the connection times (t_1 / t_{11}) by 20 – 50 % using suitable wiring.

► **Please contact *mayr*[®] power transmission.**



Check the overexcitation time even when using *mayr*[®]-DC voltage modules, as the overexcitation time is not pre-set ex works.

5.4 Friction Power / Friction Work

Permitted Friction Work Values

The brake linings are not maintenance-free. During each braking procedure, lining wear occurs. The linings or the entire rotor must be replaced after a defined number of braking actions. The number of possible switchings is dependent on the switching work per switching and the speed. When the wear becomes excessive, the brake will no longer release. The electromagnet is too weak to attract the armature disk via the large air gap. The brake remains in braking position. The braking torque is guaranteed. No signal change takes place on the release monitoring, and the machine should report a fault. This condition is not achieved on such applications under "normal" conditions, as the brake only acts with a holding function when at a standstill and with the axis drives switched off. Only in case of emergency does the brake have to delay the axis. In this case, lining wear occurs. The wear reserve on the friction linings is however dimensioned for several 10 000 such braking actions without a malfunction occurring.



For safety reasons, the ROBA®-topstop® safety brake is only to be used as a holding brake with a possible number of dynamic EMERGENCY STOP braking actions.

Not suitable for cyclic STOP braking actions in cycle operation.

When using the ROBA®-topstop® safety brake in gravity-loaded axes, the number of dynamic EMERGENCY STOP braking actions should not exceed approx. 2000 times within the total application timeframe.

For dynamic EMERGENCY STOP braking actions, the following maximum switching work values are possible:

- a) The switching work values stated in the table are valid for a max. switching frequency of 1-3 switchings (= individual events) per hour.

Permitted Switching Work $Q_{r \text{ zul.}}$ per Braking				Speed						
	Size	Type			1500 rpm	3000 rpm	4000 rpm	5000 rpm	6000 rpm	
$Q_{r \text{ zul.}}$	100	899_._._.1_	Standard	Braking torque M_N	[J/braking]	7000	5500	4000	3000	2000
			Increased			4500	3000	2000	1000	800
	120	899_._._.1_	Standard			9000	4500	1500	1000	-
			Increased			6000	2500	700	400	-
	150	899_._._.1_	Standard			11000	6000	2000	-	-
			Increased			7500	3500	1000	-	-
	175	899_._._.1_	Standard			15000	7500	4500	-	-
			Increased			9000	4500	2400	-	-
	200	899_._._.1_	Standard			22000	9000	-	-	-
			Increased			15000	6000	-	-	-
	260	899_._._.1_	Standard			32000	14000	-	-	-
			Increased			18000	6500	-	-	-

- b) For a switching frequency of up to 10 switchings per hour a factor of 0.5 for the stated switching work values must be taken into account.
Example: Size 120 / Type 899_._._.2_ / speed = 1500 rpm => permitted friction work $Q_{r \text{ zul.}}$ = 3000 J/braking action.

- c) Special dimensioning is necessary for higher speeds. ► Please contact **mayr®** power transmission.

Permitted Friction Work $Q_{r \text{ ges.}}$ up to Rotor Replacement		Size					
		100	120	150	175	200	260
$Q_{r \text{ ges.}}$	[10 ⁶ J]	17	28	65	100	180	300



Due to various operating parameters such as sliding speed, pressing or temperature the wear values can only be considered guideline values.

6 Intended Use

See also section [2.3](#)

6.1 Guidelines for Application

- Only for use as holding brake with a limited number of EMERGENCY STOP braking actions. Not suitable for cyclic STOP braking actions in cycle operation. With designs featuring an optional release monitoring with microswitch, please observe the switching frequency.
- Please observe the correct dimensioning of speed, braking torque, friction work and switching frequency in case of EMERGENCY STOP for safe holding of the load torque and safe compliance of the required braking distance and overtravel time.
- The stated switching times can only be achieved using the respective correct electrical wiring. This also refers to the protection circuit for brake control and the response delay times of all control components.
- Temperatures over 80 °C on the brake housing when the machine is in use may influence the switching times and braking torque levels. The brake and the achieved braking torque must be tested in the application.
- Application in clean environments (penetration of coarse-grained dust and liquids such as oils can have a negative effect on the braking function).
- Application in enclosed buildings (In tropical regions, in high humidity with long downtimes and sea climates only after taking special measures).
- Intended for motor-side mounting onto synchronous and asynchronous servomotors.

6.2 Limits

- Not suitable for permanent braking of a rotary movement (e.g. start - stop operation)
- The brake is not suitable for use in oily or severely contaminated environments
- The brake is not suitable for application in high ambient temperatures >40 °C
- The brake is not suitable for application in high air humidity > 80 % rel. air humidity
- The brake is not suitable for mounting onto a combustion engine

6.3 Reasonably Foreseeable Misuse

The following uses are prohibited and may generate hazards.

- Any opening of the screws on the housing.
- Use of the brake in an oily environment
- Starting up against a closed brake due to incorrect release monitoring evaluation. Overlaps in the control sequence.
- Exceeding the friction power see section [5.4](#)

6.4 Duration of Use

20 years or on reaching the T10d (for definition, see EN ISO 13849-1) duration of use.

6.5 Application Test

Basically, the ROBA®-topstop® is designed for static attachment.

Shocks, accelerations / retardations and vibrations can result from the application. Moving parts in particular can be excited in this way.

It must be ensured that these application-dependent influences do not damage the brake.

Examples of possible damages:

- Safety-critical gear wear of the components rotor, shaft, hub
- The brake mounting is subjected to unpermitted stress.



Possible damage to the brake represents a safety risk and can lead to brake failure.



Components attached to the brake (e.g.: motor) can also be excited.

6.6 Brake Dimensioning

1. Dimensioning the brake static holding torque according to the system load torque

(The carriage is held safely in the holding position via the brake)

$$M_{N -20\%} > M_L \times S$$

2. Checking the braking distance (stopping distance) by taking the following into account:

(Guaranteeing the required minimum braking distance for the protection of people or from collisions)

- All rotatory mass inertias (motor, brake, drive elements, etc.)
- All translationally moved masses and loads
- Inclination of the gravity-loaded axis
- Transmissions via gear, spur gear and toothed belt levels as well as via spindle pitches
- Path feed speed and direction from which the axis is braked
- All system times such as proximity switch response time, controls processing time and brake connection time t_1 / t_{11} - times
- Total efficiency of the input axis

The following applies: **Total braking distance < required braking distance x safety factor**



During the system running times, the input speed might increase depending on the total efficiency and load. Please take this into account when calculating the friction power

3. Taking the inspection and test torques into account

See section 11.2 brake test static

4. Inspection of thermic load Q_r

$$Q_r = \frac{J \times n^2}{182.4} \times \frac{M_N}{M_V}$$

$$M_V = M_N - M_L \quad (-) \text{ is valid if load is braked during downward}$$

$M_{N -20\%}$	[Nm]	Brake minimum braking torque (= braking torque - 20% x braking torque) see Technical Data (section 5.2)
Q_r	[J/braking]	Friction work present per braking
S	[-]	Recommended safety factor min. 1.5 – 2 depending on the application*
J	[kgm ²]	Total mass moment of inertia referring to the brake
M_N	[Nm]	Brake nominal torque (see Technical Data section 5.2)
M_V	[Nm]	Deceleration torque
M_L	[Nm]	Load torque on system

* Taking the machine-specific standards and specialist literature into account (state of the art)

The permitted friction work $Q_{r \text{ zul.}}$ per braking action with 1 – 3 switching actions (reduction of the friction work after several switchings), see [5.4](#).



Guaranteeing the necessary braking distances with all control and braking times in case of danger due to gravity-loaded axes must be checked via a test. A cyclic braking torque test of the brake rotor during operation provides additional safety.

Depending on the danger, please observe the respective regulations / standards.

Operational Instructions for ROBA®-topstop® Type 899_._._._._ Size 100 - 260

(B.899.EN)

6.7 Outer Parameters

6.7.1 Permitted Motor Attachments/ Breakdown Torques

The permitted breakdown torques of the motor screwed onto the brake module include the static and dynamic loads “F” of motor weight, mass acceleration and influences caused through shocks and vibrations, multiplied by the motor centre of gravity clearance „I_s“.

$$M_k = F \times I_s \leq M_{k \text{ zul.}}$$

Permitted Breakdown Torque	Size	Size					
		100	120	150	175	200	260
M _{k zul.}	[Nm]	25	45	90	135	200	450

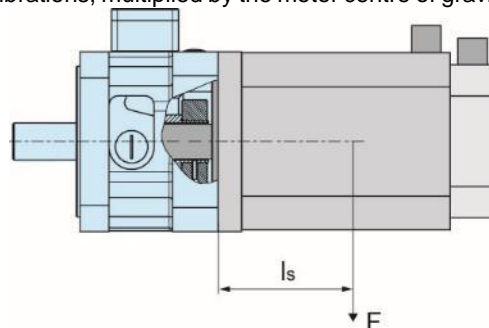

6.7.2 Permitted Outer Acceleration and Deceleration Torques on the Brake

Please Observe: Consider the transmittable torques of all connections of the brake (clamping hub, shrink disk hub, shaft, flexible coupling).

	Types			Size					
				100	120	150	175	200	260
1	all Types	M _{Beschl}	[Nm]	16	40	125	170	225	560
2									
3	all Types except 899_._.__2_	M _{Brems}	[Nm]	8	24	62	70	85	280
4	899_._.__2_	M _{Brems}	[Nm]	No further braking torque permitted through motor brake					

1) All negative acceleration torques acting on the ROBA®-topstop® brake. For example, these can be negative acceleration torques from a holding brake or from a motor in braking operation (eddy current operation).

6.7.3 Permitted Shaft Loads

Max. radial forces on the bearing applicable for: Type **8990.000_._**

ROBA®-topstop® brake		Size					
Distance „I _R “ (Fig. 17)	[mm]	100	120	150	175	200	260
Max. permitted radial force „F _R “ with distance I _R	[N]	250	600	1000	1500	1500	3000
The permitted forces refer to a max. speed of	[rpm]	6000	5000	4000	4000	3000	3000
Nominal service life-time	[h]	30000	30000	25000	25000	15000	15000

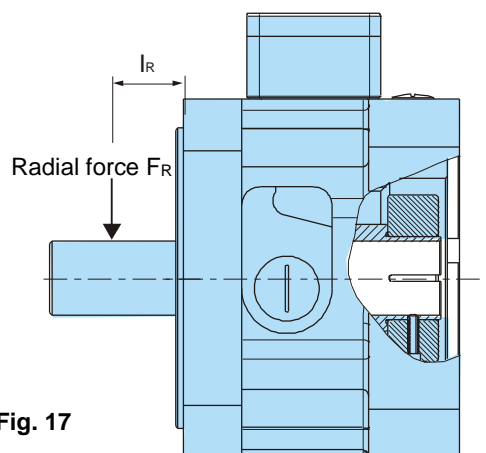

Fig. 17

The values refer to purely radial forces. The permitted forces are applicable for shaft dimensions, with a force application point for radial forces in the centre of the output shaft.

7 Electrical Connection and Wiring

DC current is necessary for operation of the brake. The coil nominal voltage is indicated on the Type tag as well as on the brake body and is designed according to the DIN IEC 60038 ($\pm 10\%$ tolerance). Operation can take place with alternating voltage using a rectifier or another suitable DC power supply. The connection possibilities can vary dependent on the brake equipment. Please follow the exact connections according to the section **10.11**. The manufacturer and the user must observe the applicable regulations and standards (e.g. DIN EN 60204-1 and DIN VDE 0580). Their observance must be guaranteed and double-checked!

7.1 Grounding Connection

The brake is designed for Protection Class I. This protection covers not only the basic insulation, but also the connection of all conductive parts to the protective conductor (PE) on the fixed installation. If the basic insulation fails, no contact voltage will remain. Please carry out a standardised inspection of the protective conductor connections to all contactable metal parts!

For the protective conductor connection, marked connection points are available in the terminal box (15).

7.2 Fuse Element

To protect against damage from short circuits, please add suitable fuse elements to the mains cable/supply line.



7.3 Switching Behavior

The reliable operational behavior of a brake is to a large extent dependent on the switching mode used. Furthermore, the switching times are influenced by the temperature and the air gap between the armature disk and the coil carrier (dependent on the wear condition of the linings).

7.4 Switching Modes

The separation time (t_2) and the connection time (t_1) of the brake are substantially influenced depending on the electrical wiring of the magnetic coil (see section **5.3**).

7.4.1.1 Field build-up with normal excitation

Determination of the separation time (t_2).

If the magnetic coil is energised with coil nominal voltage, the coil current does not immediately reach its nominal value. The coil inductivity causes the current to increase slowly as an exponential function. Accordingly, the build-up of the magnetic field takes place more slowly and the braking torque drop (see Diagram 3/curve 1) is also delayed.

For this type of wiring, no electrical construction elements are required as long as the DC supply voltage equals the coil nominal voltage on the magnetic coil.

7.4.1.2 Field Build-up with Overexcitation

Quicker Release

Determination of the separation time (t_2)

A quicker drop in braking torque is achieved if the coil is temporarily placed under a higher voltage than the coil nominal voltage, as the current then increases more quickly. Once the brake is released, it needs to be switched over to the coil nominal voltage U_N (see Diagram 3/curve 2). The relationship between overexcitation and separation time t_2 is roughly indirectly proportional, meaning that at doubled coil nominal voltage the separation time t_2 for release of the brake is halved. For this, further wiring modules are required. The ROBA®-switch, ROBA®-multiswitch and ROBA®-brake-checker plus AC work on this principle.

Increased spring force

Generally, overexcitation of the magnetic coil is also required if the brake has an increased braking torque (Type 899_._._._2_), and an increased magnetic force is required to attract the armature disk against the increased spring forces.

Current path

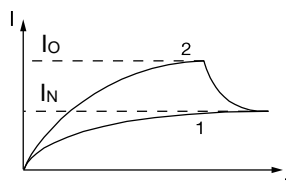

Braking torque path

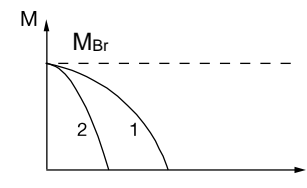

Diagram 3:

- Operation with overexcitation requires an inspection of:
- the required overexcitation time
 - the **RMS coil capacity** with a cycle frequency higher than 1 cycle per minute.

7.4.1.3 Calculation during Field Build-up with Overexcitation

Required overexcitation time

Increased wear, and therefore an increasing air gap as well as coil heating lengthen the separation times t_2 for the brake. For this reason, at least 2.5 times the separation time t_2 at nominal current I_N must be selected as overexcitation time t_o .

RMS coil capacity P



$$P \leq P_N$$

The coil capacity P must not be larger than P_N . Otherwise the coil may fail due to thermal overload.

Key and Calculations:

P	[W]	RMS coil capacity dependent on switching frequency, overexcitation, reduction in capacity and duty cycle
$P = \frac{P_O \times t_o + P_H \times t_H}{T}$		
P _N	[W]	Coil nominal capacity Type 899_._._._1_ (Technical Data, type tag)
P _O	[W]	Coil capacity on overexcitation Type 899_._._._2_ (Technical Data)
P _H	[W]	Coil capacity on overexcitation Type 899_._._._2_ (Technical Data, type tag)
t _o	[s]	Overexcitation time
t _H	[s]	Holding time Type 899_._._._2_
t _{on}	[s]	Time with voltage
t _{off}	[s]	Time without voltage
T	[s]	Total time (t _o + t _H + t _{off})
U _O	[V]	Overexcitation voltage (bridge voltage)
U _H	[V]	Holding voltage (half-wave voltage)
U _N	[V]	Coil nominal voltage
I _o	[A]	Overexcitation current
I _N	[A]	Nominal current
M _{Br}	[Nm]	Braking torque

7.4.1.4 Time Diagram:

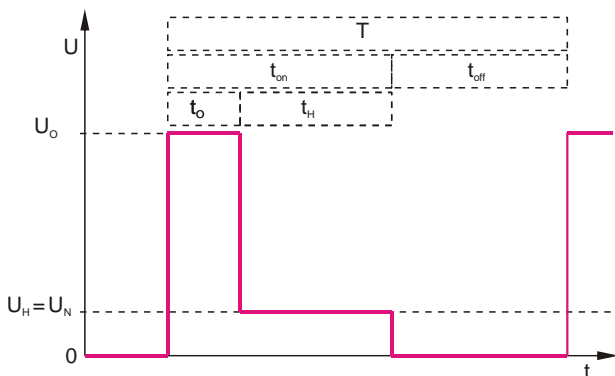

7.4.2 Magnetic Field Removal

Determination of the connection time (t₁)

7.4.2.1 AC-side Switching/Switching with Freewheeling Diode

a) Rectifier module for supply with AC voltage

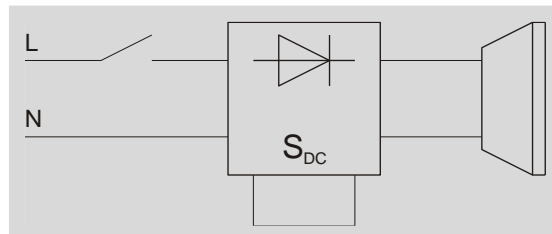

Schematic wiring diagram 1

The power circuit is interrupted in front of the rectifier. The magnetic field slowly reduces. This delays the rise in braking torque and generates a slow connection time t₁.

b) For supply with DC voltage

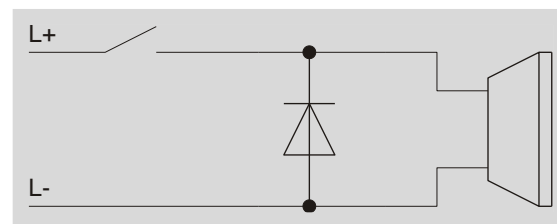

Schematic wiring diagram 2

The power circuit is interrupted in front of the freewheeling diode. The magnetic field slowly reduces. This delays the rise in braking torque and generates a slow connection time t₁. The freewheeling diode is to be dimensioned in accordance with the nominal current of the brake and the maximum occurring supply voltage with the appropriate safety factor.



Recommendation!

Connection time t₁ is of no consequence:

- Switch AC-side or with the freewheeling diode. No protective measures for the coil and switching contacts required.

AC-side switching/ switching with freewheeling diode means a longer brake engagement time (approx. 6 – 10 times longer than with DC-side switch-off), use for non-critical braking times.

7.4.2.2 DC-side switching

a) Rectifier module for supply with AC voltage

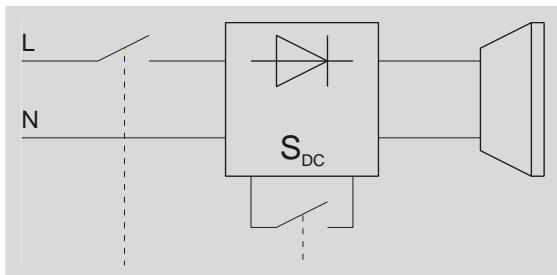

Schematic wiring diagram 3

The power circuit is interrupted between the rectifier and the coil as well as mains-side. The magnetic field reduces extremely quickly. This causes a quick rise in braking torque.

b) For supply with DC voltage

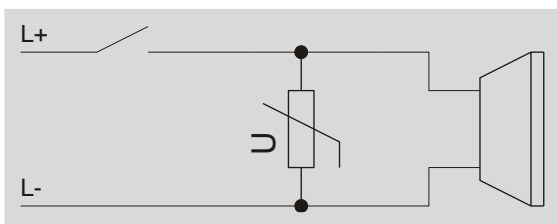

Schematic wiring diagram 4

The power circuit is interrupted between the power supply and the coil. The magnetic field is quickly reduced via the protective element. This causes a quick rise in braking torque and a quick connection time t_1 . The varistor is to be dimensioned in accordance with the maximum occurring DC or AC voltage. The recommended disk diameters are 14 – 20 mm.

When switching DC-side, high voltage peaks are produced in the coil. This can lead to wear on the switching contacts from sparks and to destruction of the insulation. For this reason, the voltage peaks must be limited (see section [7.5](#)).

DC-side switching causes the **shortest connection times on the brake (e.g. for EMERGENCY STOP operation or for safety switch-offs)** so that the braking torque is made available as quickly as possible for short braking distances or for fast take-over of loads.



Please Observe!

Safety switch-off

In applications with a necessarily short switching time for short braking distances and fast take-over of loads, reliable DC-side switch-off is required e.g. through redundant, monitored contactors. (see schematic wiring diagram 5)

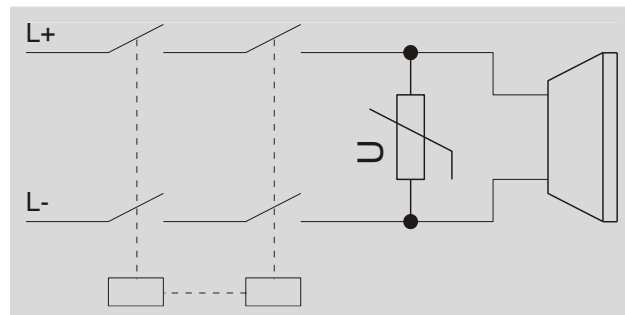

Schematic wiring diagram 5

7.5 Protection Circuit

When using DC-side switching, the coil must be protected by a suitable protection circuit according to VDE 0580, which is integrated in *mayr*®-rectifiers. To protect the switching contact from consumption when using DC-side switching, additional protective measures are necessary (e.g. series connection of switching contacts). The switching contacts used should have a minimum contact opening of 3 mm and should be suitable for inductive load switching. Please make sure on selection that the rated voltage and the rated operating current are sufficient. Depending on the application, the switching contact can also be protected by other protection circuits (e.g. *mayr*®-spark quenching unit), although this may of course then alter the switching times.

The following parameters can be changed through suitable adaptations of the protection circuit.

- Contact lifetime
- Switching times on drop-out
- Voltage peaks or level of switch-off voltage

Please contact *mayr*® power transmission.



Please Observe!

For accessories, please go to www.mayr.com

8 Functional Safety Parameters

Consideration of the mean time to dangerous failure for ROBA®-topstop® brake systems in accordance with DIN EN ISO 13849-1 Safety of machinery – Safety related parts of control systems

8.1.1 Definition

The mean time to dangerous failure $MTTF_d$ describes the reliability of the components used. In DIN EN ISO 13849, the $MTTF_d$ is defined as the "Expected mean time to dangerous failure", which emphasises several aspects:

- $MTTF_d$ is a static value, i.e. an empirically generated value or classification number which has nothing in common with a "guaranteed lifetime", "failure-free period" or similar.
- $MTTF_d$ has the physical dimension of a time and is usually stated in years. The simplified quantification procedure in accordance with DIN EN ISO 13849-1 assumes a standard duration of use of max. 20 years.
- This only concerns failures with dangerous consequences, i.e. those which affect the execution of the safety function.

The value B10d states the number of cycles until 10% of the components have suffered dangerous failures (definition acc. EN ISO 13849-1).

With regard to the brakes, these are:

- The mechanical switching process.
- The movement of the armature disk.

Here dangerous failures means that the brake does not engage on request and therefore does not generate the required braking torque.

The wear on the brake lining has no influence on this value (e.g. the wear during a dynamic braking action).

Due to the "quiescent current principle" at the wear end of the brake, the required braking torque is still available, meaning that no dangerous failures can occur.

For the precise calculation of the wear value, the braking work per switching and the switching cycle quantity in the application per year must be determined (see section [6.6](#)).

Definition of the category:

The categories classify safety-related components with regard to their resistance against errors and their behaviour in case of error, based on the reliability and the structural arrangement of the parts. A higher resistance capability against errors means a higher possible reduction of risk.

All ROBA®-topstop® brakes fulfil Category 1 in accordance with DIN EN ISO 13849-1.

Braking device as tried and tested component in terms of the Category 1 acc. DIN EN ISO 13849-1
→ see section [3.9](#)

8.1.2 Functional Safety Regulations

The brake safety is generated through the braking torque. For safe and reliable braking and for error-free operation of the ROBA®-topstop® brakes, the following points are required:

- Sufficient dimensioning
- Intended use
- Maintenance of the application limits
- Maintenance of the technical fringe parameters



Brake dimensioning see section [6.6](#)

So that the required load torque can be held reliably, and the required braking distance can be reliably maintained, the following points are to be determined:

- The static holding torque
- The dynamic braking torque
- The speed
- The friction work per braking action
- The switching frequency
- The braking time



A positive locking connection increases the reliability against inadvertent slipping of the connection and the related risks.

See section [4.6.1](#).

For fulfilment of the safety functions, the safety brake is only to be considered as an individual component, and not as a safety-orientated subsystem. The safety brake alone is not sufficient to execute the safety function in accordance with the standard. To do this, the brake wiring and the signal return etc. must also be observed.



In general, the following applies:

The brake provides no single error reliability.
One error, and the resulting loss of braking torque, is possible.

The efficacy and function of the brake is to be inspected due to the overall risk assessment to be carried out and the resulting measures for risk minimisation depending on the application case through suitable tests at appropriate time intervals (safe brake test SBT, safe brake management SBM, safe brake and holding system SBS etc.). The release monitoring signal can increase the diagnostic coverage DC. Brake errors which influence the release of the armature disk or the energisation of the brake can thus be determined. In order to detect effective brake or release monitoring errors, it is necessary to query the control expectations on the commands "Brake - Energised" and "Brake - De-energised" according to the Technical Data for the brake used.

Brake - energised: Signal change from "Brake closed" to "Brake open" within a certain time (e.g. 3 x t₂-time) see section 10.12.

Brake - de-energised: Signal change from "Brake opened" to "Brake closed" within a certain time (e.g. 3 x t₁-time) see section 10.12.



It must be ensured that the drive cannot start up against the closed brake. This can be monitored via brake-side release monitoring.



Test principle
See also the Division Information Sheet "Gravity-loaded axes – (Vertical axes)" DGUV section 6, section 11.2.

8.1.3 Condition



Brakes which are used in safety-related applications are to be selected in accordance with the risk assessment EN ISO 12100 and furthermore in accordance with EN ISO 13849-1 through identification of the safety function. This is in principle the task of the system manufacturer.

The Performance Level (PL) can only be determined on consideration of all safety-related parts of the safety channel such as the control and additional braking or holding devices etc. in accordance with EN ISO 13849-1.

9 Storage

9.1 Brake Storage

- Store the brakes in a horizontal position, in dry rooms and dust and vibration-free.
- Relative air humidity < 50 %.
- Temperature without major fluctuations within a range from 10 °C up to +40 °C.
- Do not store in direct sunlight or UV light.
- Do not store aggressive, corrosive substances (solvents / acids / lyes / salts etc.) near to the brakes.

For longer storage of more than 2 years, special measures are required.

► **Please contact *mayr*®.**

10 Installation

10.1 Mounting Conditions

- ❑ Please keep to the dimension z_2 (see sections **10.8**, **10.9**, **10.10**) for the customer-side friction flange (36) acc. table in section **4.5** (Tolerance – 0.03 mm).
- ❑ The tensile strength R_m of the attachment wall must be at least 300 N/mm². Lower strength values must be approved by *mayr*® power transmission.
- ❑ A suitable counter friction surface (steel or grey cast iron) must be used. Sharp-edged interruptions on the friction surfaces must be avoided.
- ❑ Max. permitted surface roughness depth of the friction surface $R_a = 1.6 \mu\text{m}$.
- ❑ The max. permitted unevenness of the friction surface is 0.03 mm.
- ❑ For customer-side attachment, axial run-out and shaft run-out tolerances of 0.03 mm are necessary.

Larger deviations affect the function and the installation of the brake or can lead to a drop in braking torque, to continuous grinding of the rotor (22) and to overheating.
- ❑ Tolerance for customer-side shafts: k6
- ❑ The shaft/spindle must be axially backlash-free customer-side (backlash-free locating bearing). Axial backlash affect the function of the brake or can lead to continuous grinding of the rotor (22) and to overheating.

10.2 Installation Conditions

- ❑ The rotor (22) and brake surfaces must be oil and grease-free.
- ❑ The permitted radial forces on the shaft (Item 7) acc. section **6.7.3** must not be exceeded.
- ❑ When installing a ROBA®-topstop®, do not place it on the terminal box; avoid any adjustment or damage.
- ❑ The minimum property class of the customer-side cap screws (17/18) is 8.8. Tighten the screws using a torque wrench!
- ❑ Please keep to the installation dimensions $W/Y_1/Y_2$, see table in section **4.5**, as otherwise the brake function cannot be guaranteed.
- ❑ Please make sure that the max. permitted shaft misalignments and torques defined in the Installation and Operational Instructions for the shaft coupling are not exceeded (see attached Installation and Operational Instructions B.9.6).
- ❑ Please use distance rings as limit stops for keeping to the machine-side dimensions.

CAUTION Please observe the own weight of the brake



The brake may drop during transport / assembly. The consequences may be crush injuries and impact injuries. For Size 260, use an eyebolt for lifting aids.

WARNING Load crash possible



The brake only functions reliably subsequent to initial operation.
Support the load!

10.3 Brake Type 8990.000_ _

Installing the brake onto the machine:

1. Open the screw plug (16). Check the alignment of the cap screw (10) and the bore for the screw plug (16) and make sure that the cap screw (10) is loosened.
2. Mount the brake assembly onto the machine using customer-side cap screws (17) (please observe the tightening torque acc. table in section **4.5**).
3. Clamp the shaft (7) onto the output side (machine-side).

Installing the motor onto the brake:

4. Push the motor (shaft) into the brake, bring it into position and tighten it to the tightening torque acc. table in section **4.5** using customer-side cap screws (18).



The shaft is centred via the rotor (22) in the brake. If necessary, release (energise) the brake if the motor cannot be inserted easily into the centering. The motor can then be moved slightly radially during joining.

Please observe the required shaft length "l₃" and the threaded hole depth "b" acc. table in section **4.5**

5. Tighten the cap screw (10) to the tightening torque acc. table in section **4.5**.
6. Close the screw plug (16) again.

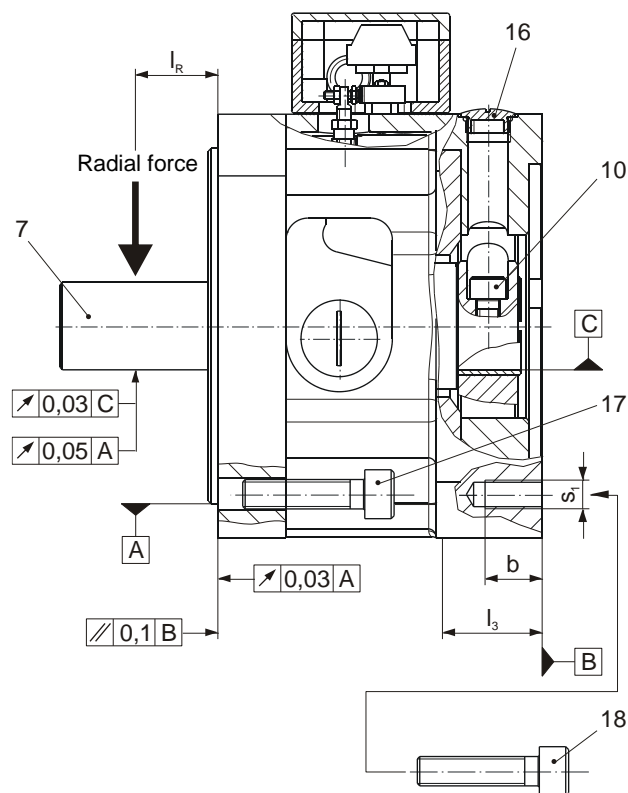

Fig. 20

10.4 Brake Type 8990.01_._._

Installing the brake onto the machine:

1. Mount the brake assembly onto the machine using customer-side cap screws (17) (please observe the tightening torque acc. table in section [4.5](#)).
2. Clamp the shaft (32) onto the output side (machine-side).

Installing the motor onto the brake:

3. Check whether the cap screw (4) is loosened in the clamping hub (3).
4. Push the clamping hub (3) with the inserted elastomeric element (11) onto the motor shaft, and adjust using axial movement to the installation dimension "Y1/Y2" acc. table in section [4.5](#). We recommend an adjusted distance ring as a fixed limit stop.



Please observe the required shaft length "l₃" acc. table in section [4.5](#)

5. Tighten the cap screw (4) to the tightening torque acc. table in section [4.5](#).
6. Check the installation dimension "Y1/Y2" acc. table in section [4.5](#) and correct again if necessary.
7. Bring the brake and the motor into position with each other and push them together carefully. If necessary, turn the motor shaft slightly, so that the claws of the clamping hub (3) can be inserted into the elastomeric element (11).



Do not use force.
If necessary, release (energise) the brake if the motor cannot be inserted easily into the centring. The motor can then be moved slightly radially during joining.

8. Screw the brake and the motor together with each other using four customer-side cap screws (18) to the tightening torque acc. table in section [4.5](#).

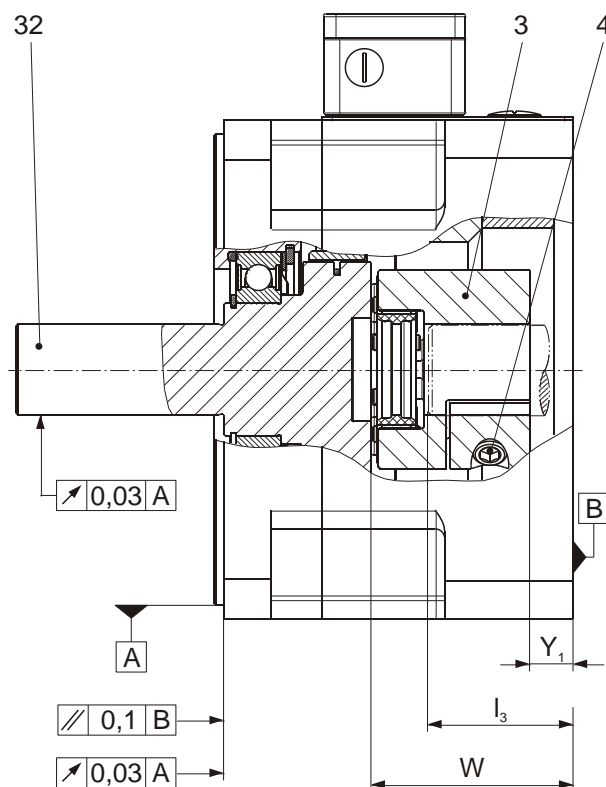

Fig. 21

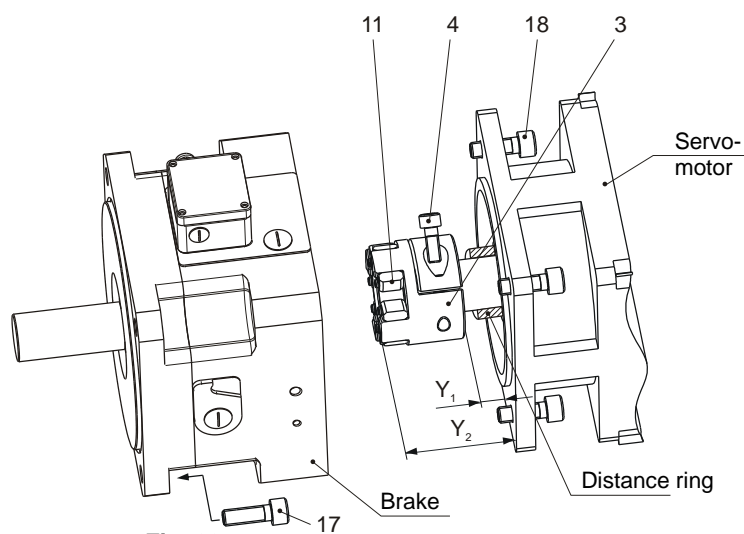

Fig. 22

10.5 Brake Type 8990.02_._._

Installing the brake onto the machine:

1. Mount the brake assembly onto the machine using customer-side cap screws (17) (please observe the tightening torque acc. table in section 4.5).
2. Clamp the shaft (32) onto the output side (machine-side).

Installing the motor onto the brake:

3. Remove the elastomeric element (11).
4. Check whether the cap screws (6) are loosened in the drive-side shrink disk hub (5).
5. Push the drive-side shrink disk hub (5) onto the motor shaft, and adjust using axial movement to the installation dimension "Y1/Y2" acc. table in section 4.5. We recommend an adjusted distance ring as a fixed limit stop.



Please observe the required shaft length "l₃" acc. table in section 4.5

6. Tighten the cap screws (6) stepwise (in 3 to max. 6 tightening sequences) and cross-wise to the tightening torque acc. table in section 4.5.
7. Check the installation dimension "Y1/Y2" acc. table in section 4.5 and correct again if necessary.
8. Re-insert the elastomeric element (11).
9. Bring the brake and the motor into position with each other and push them together carefully. If necessary, turn the motor shaft slightly, so that the claws of the shrink disk hub (5) can be inserted into the elastomeric element (11).



Do not use force.
If necessary, release (energise) the brake if the motor cannot be inserted easily into the centring. The motor can then be moved slightly radially during joining.

10. Screw the brake and the motor together with each other using four customer-side cap screws (18) to the tightening torque acc. table in section 4.5.

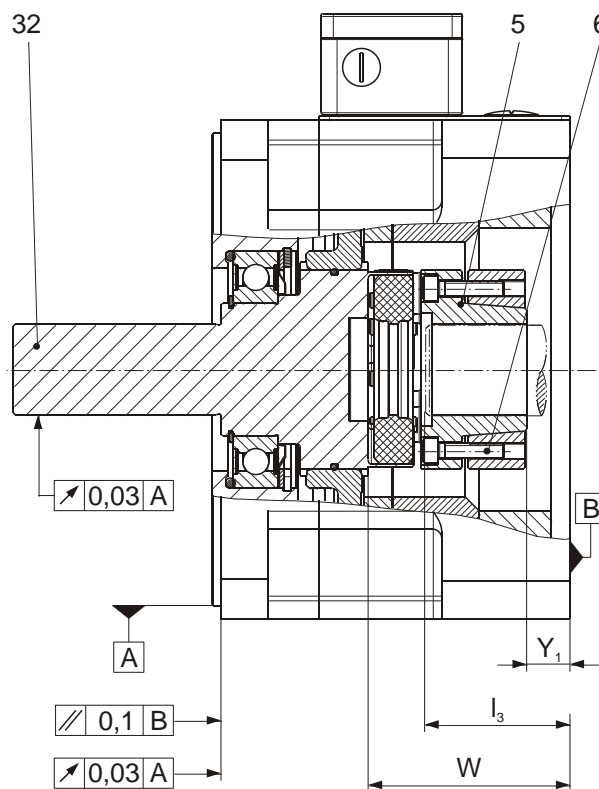

Fig. 23

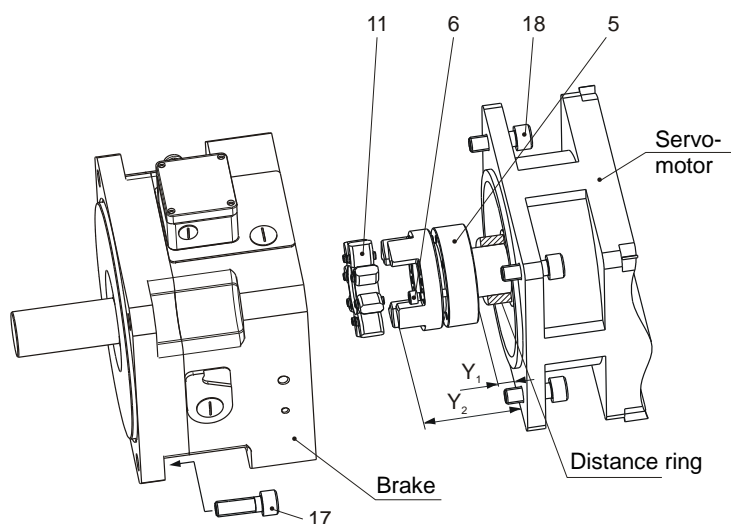

Fig. 24

10.6 Brake Type 8990.11_._._

Installing the brake onto the machine:

1. Check whether the cap screws (2) are loosened.
2. Push the pre-assembled brake over the machine shaft.



Please observe the required shaft length " l_2 " acc. table in section **4.5**

3. Screw in the cap screws (17) for the brake/machine (leave approx. 5 mm stroke, see Fig. 26).
4. Adjust the output-side shrink disk hub (1) using axial movement to the installation dimension " W " acc. table in section **4.5**. We recommend an adjusted distance ring as a fixed limit stop.
5. Tighten the cap screws (2) stepwise (in 3 to max. 6 tightening sequences) and cross-wise to the tightening torque acc. table in section **4.5**.
6. Pull the brake back to contact on the screw heads (17) (fixing screws for brake/machine), then push them again against the machine (reason: release of the rotor (22)).
7. Tighten the cap screws (17) for the brake/the machine.

Installing the motor onto the brake:

8. Check whether the cap screw (4) is loosened in the clamping hub (3).
9. Push the clamping hub (3) with the inserted elastomeric element (11) onto the motor shaft, and adjust using axial movement to the installation dimension " Y_1/Y_2 " acc. table in section **4.5**. We recommend an adjusted distance ring as a fixed limit stop.



Please observe the required shaft length " l_3 " acc. table in section **4.5**

10. Tighten the cap screw (4) to the tightening torque acc. table in section **4.5**.
11. Check the installation dimension " Y_1/Y_2 " acc. table in section **4.5** and correct again if necessary.
12. Bring the brake and the motor into position with each other and push them together carefully. If necessary, turn the motor shaft slightly, so that the claws of the shrink disk hub (1) can be inserted into the elastomeric element (11).



Do not use force.
If necessary, release (energise) the brake if the motor cannot be inserted easily into the centring. The motor can then be moved slightly radially during joining.

13. Screw the brake and the motor together with each other using four customer-side cap screws (18) to the tightening torque acc. table in section **4.5**.

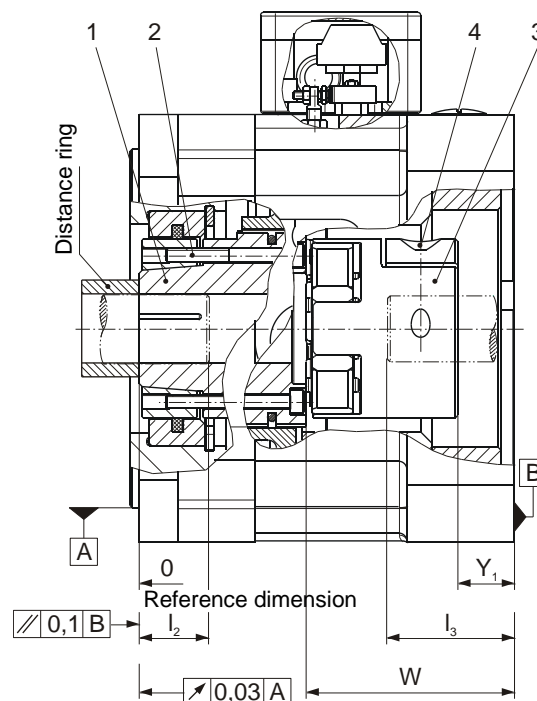

Fig. 25

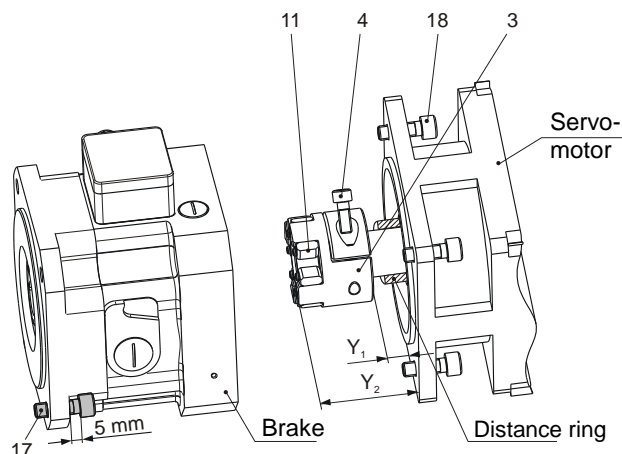

Fig. 26

10.7 Brake Type 8990.12_._._

Installing the brake onto the machine:

1. Check whether the cap screws (2) are loosened.
2. Push the pre-assembled brake over the machine shaft.



Please observe the required shaft length "l₂" acc. table in section **4.5**

3. Screw in the cap screws (17) for the brake/machine (leave approx. 5 mm stroke, see Fig. 28).
4. Adjust the output-side shrink disk hub (1) using axial movement to the installation dimension "W" acc. table in section **4.5**. We recommend an adjusted distance ring as a fixed limit stop.
5. Tighten the cap screws (2) stepwise (in 3 to max. 6 tightening sequences) and cross-wise to the tightening torque acc. table in section **4.5**.
6. Pull the brake back to contact on the screw heads (17) (fixing screws for brake/machine), then push them again against the machine (reason: release of the rotor (22)).
7. Tighten the cap screws (17) for the brake/the machine.

Installing the motor onto the brake:

8. Remove the elastomeric element (11).
9. Check whether the cap screws (6) are loosened in the drive-side shrink disk hub (5).
10. Push the drive-side shrink disk hub (5) onto the motor shaft, and adjust using axial movement to the installation dimension "Y₁/Y₂" acc. table in section **4.5**. We recommend an adjusted distance ring as a fixed limit stop.



Please observe the required shaft length "l₃" acc. table in section **4.5**

11. Tighten the cap screws (6) stepwise (in 3 to max. 6 tightening sequences) and cross-wise to the tightening torque acc. table in section **4.5**.
12. Check the installation dimension "Y₁/Y₂" acc. table in section **4.5** and correct again if necessary.
13. Re-insert the elastomeric element (11).
14. Bring the brake and the motor into position with each other and push them together carefully. If necessary, turn the motor shaft slightly, so that the claws of the shrink disk hub (1) can be inserted into the elastomeric element (11).



Do not use force.
If necessary, release (energise) the brake if the motor cannot be inserted easily into the centring. The motor can then be moved slightly radially during joining.

15. Screw the brake and the motor together with each other using four customer-side cap screws (18) to the tightening torque acc. table in section **4.5**.

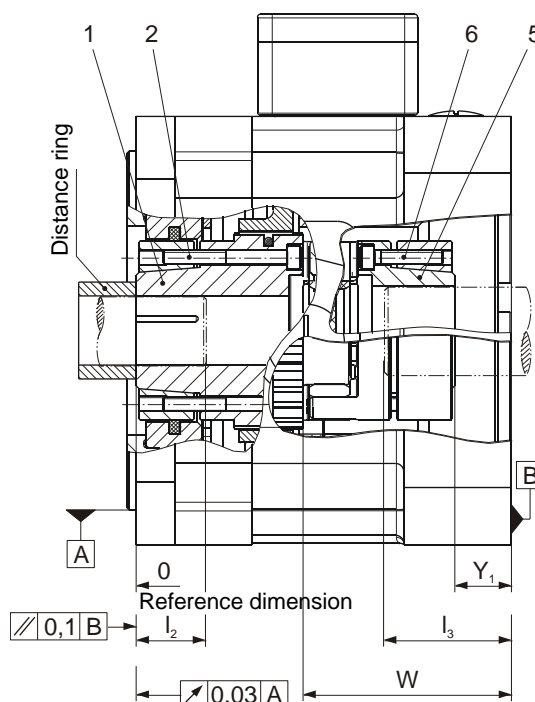

Fig. 27

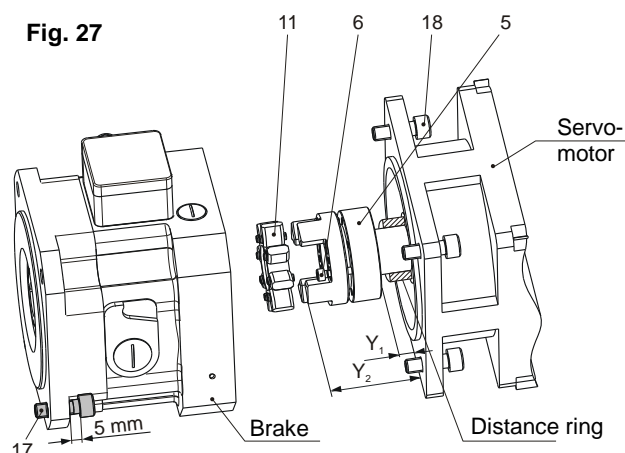

Fig. 28

10.8 Brake Type 8991.00_._._

Installing the brake onto the machine:

1. Join the shaft (7) on the output side and establish the installation dimension W_2 acc. table in section **4.5**.
2. Push the rotor (22) onto the shaft (7) toothing by hand (the rotor collar should be facing the friction flange (36)).



The rotor toothing must lie over the entire length of the shaft (7) toothing. Make sure that the toothing moves easily.

3. Push the pre-assembled brake over the shaft (7) and the rotor (22).
4. Tighten it using the cap screws (14) on the friction flange (36) to the tightening torque acc. table in section **4.5**.
5. Open the screw plug (16) and check the alignment of the cap screw (10) and the bore for the screw plug (16).



If necessary, energise the brake and turn the shaft (7) until the cap screw (10) is in position.

6. Adjust the shaft (7) to the installation dimension "Y" acc. table in section **4.5** and clamp it on the customer side.

Installing the motor onto the brake:

7. Check whether the cap screw (10) is loosened.
8. Push the motor (shaft) into the brake, bring it into position and tighten it to the tightening torque acc. table in section **4.5** using customer-side cap screws (18).



If necessary, release (energise) the brake if the motor cannot be inserted easily into the centring. The motor can then be moved slightly radially during joining.

Please observe the required shaft length " l_3 " and the threaded hole depth "b" acc. table in section **4.5**

9. Tighten the cap screw (10) to the tightening torque acc. table in section **4.5**.
10. Close the screw plug (16) again.

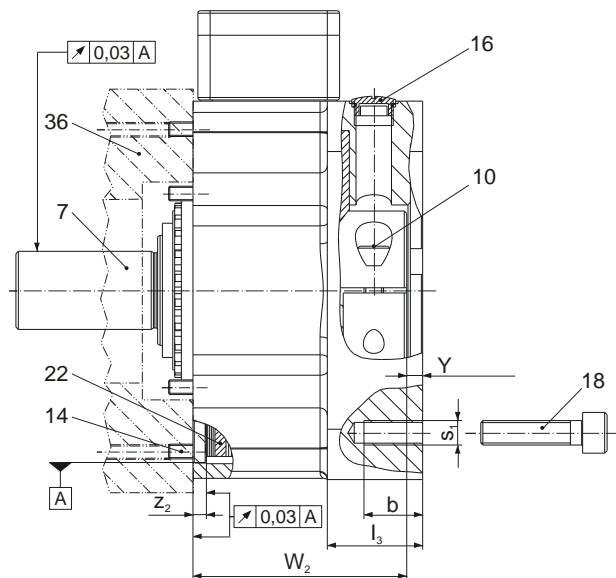

Fig. 29

10.9 Brake Type 8991.11_._._

Installing the brake onto the machine:

1. Check whether the cap screws (2) are loosened.
2. Push the output-side shrink disk hub (1) over the machine shaft and establish the installation dimension W_3 acc. table in section 4.5 (we recommend an adjusted distance ring as a fixed limit stop).



Please observe the required shaft length " l_2 " acc. table in section 4.5

3. Push the rotor (22) onto the tothing of the shrink disk hub (1) by hand (the rotor collar should be facing the friction flange (36)).



The rotor tothing must lie over the entire length of the shrink disk hub (1) tothing. Make sure that the tothing moves easily.

4. Push the pre-assembled brake over the shrink disk hub (1) and the rotor (22) and screw them down to the tightening torque acc. table in section 4.5 onto the friction flange (36) using the eight cap screws (14).
5. Adjust the output-side shrink disk hub (1) using axial movement to the installation dimension " W/W_1 " acc. table in section 4.5.
6. Tighten the cap screws (2) stepwise (in 3 to max. 6 tightening sequences) and cross-wise to the tightening torque acc. table in section 4.5.

Installing the motor onto the brake:

7. Check whether the cap screw (4) is loosened in the clamping hub (3).
8. Push the clamping hub (3) with the inserted elastomeric element (11) onto the motor shaft, and adjust using axial movement to the installation dimension " Y_1/Y_2 " acc. table in section 4.5. We recommend an adjusted distance ring as a fixed limit stop.



Minimum shaft lengthPlease observe the required minimum shaft length " l_3 " acc. table in section 4.5

9. Tighten the cap screw (4) to the tightening torque acc. table in section 4.5.
10. Check the installation dimension " Y_1/Y_2 " acc. table in section 4.5 and correct again if necessary.
11. Bring the brake and the motor into position with each other and push them together carefully. If necessary, turn the motor shaft slightly, so that the claws of the shrink disk hub (1) can be inserted into the elastomeric element (11).



Do not use force. If necessary, release (energise) the brake if the motor cannot be inserted easily into the centring. The motor can then be moved slightly radially during joining.

12. Screw the brake and the motor together with each other using four customer-side cap screws (18) to the tightening torque acc. table in section 4.5.

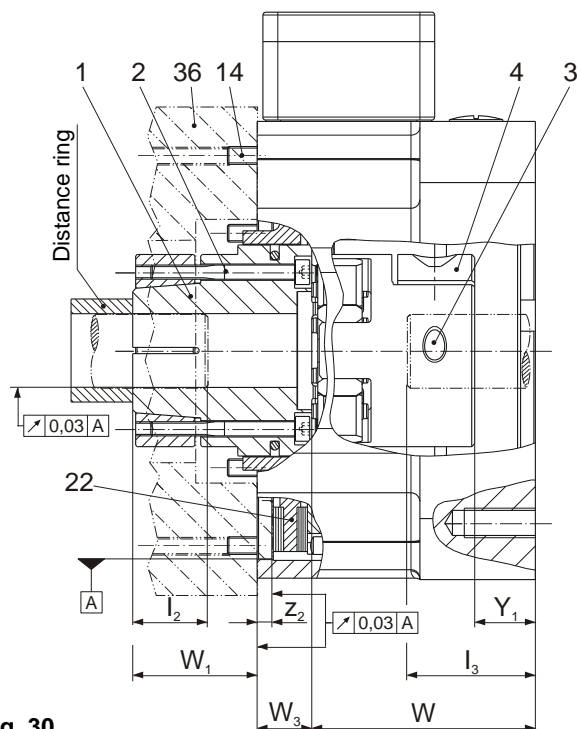

Fig. 30

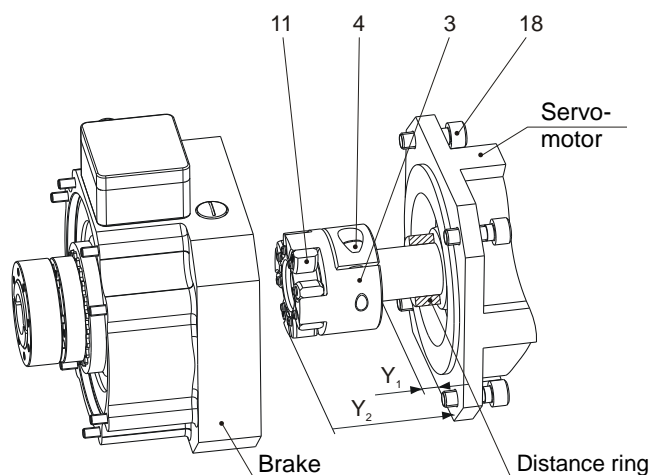

Fig. 31

10.10 Brake Type 8991.12_._._

Installing the brake onto the machine:

1. Check whether the cap screws (2) are loosened.
2. Push the output-side shrink disk hub (1) over the machine shaft and establish the installation dimension W_3 acc. table in section 4.5 (we recommend an adjusted distance ring as a fixed limit stop).



Please observe the required shaft length " l_2 " acc. table in section 4.5

3. Push the rotor (22) onto the tothing of the shrink disk hub (1) by hand (the rotor collar should be facing the friction flange (36)).



The rotor tothing must lie over the entire length of the shrink disk hub (1) tothing. Make sure that the tothing moves easily.

4. Push the pre-assembled brake over the shrink disk hub (1) and the rotor (22) and screw them down to the tightening torque acc. table in section 4.5 onto the friction flange (36) using the eight cap screws (14).
5. Adjust the output-side shrink disk hub (1) using axial movement to the installation dimension " W/W_1 " acc. table in section 4.5.
6. Tighten the cap screws (2) stepwise (in 3 to max. 6 tightening sequences) and cross-wise to the tightening torque acc. table in section 4.5.

Installing the motor onto the brake:

7. Remove the elastomeric element (11).
8. Check whether the cap screws (6) are loosened in the drive-side shrink disk hub (5).
9. Push the drive-side shrink disk hub (5) onto the motor shaft, and adjust using axial movement to the installation dimension " Y_1/Y_2 " acc. table in section 4.5. We recommend an adjusted distance ring as a fixed limit stop.



Please observe the required shaft length " l_3 " acc. table in section 4.5

10. Tighten the cap screws (6) stepwise (in 3 to max. 6 tightening sequences) and cross-wise to the tightening torque acc. table in section 4.5.
11. Check the installation dimension " Y_1/Y_2 " acc. table in section 4.5 and correct again if necessary.
12. Re-insert the elastomeric element (11).
13. Bring the brake and the motor into position with each other and push them together carefully. If necessary, turn the motor shaft slightly, so that the claws of the shrink disk hub (1) can be inserted into the elastomeric element (11).



Do not use force.

If necessary, release (energise) the brake if the motor cannot be inserted easily into the centring. The motor can then be moved slightly radially during joining.

14. Screw the brake and the motor together with each other using four customer-side cap screws (18) to the tightening torque acc. table in section 4.5.

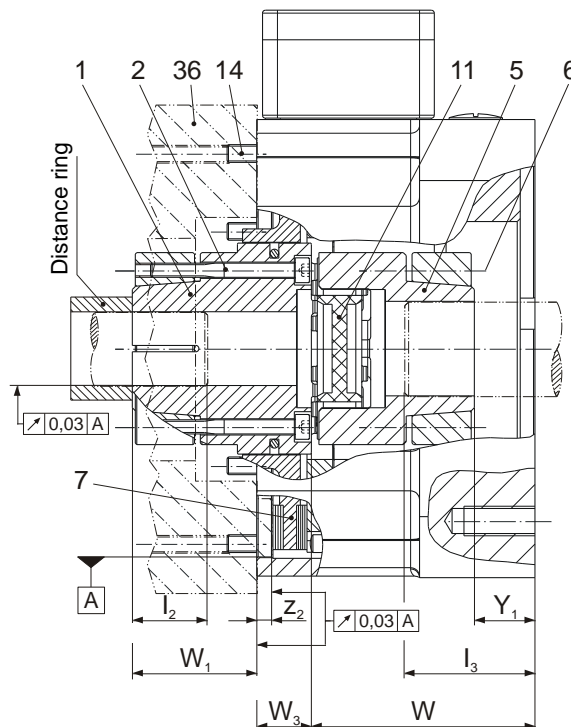

Fig. 32

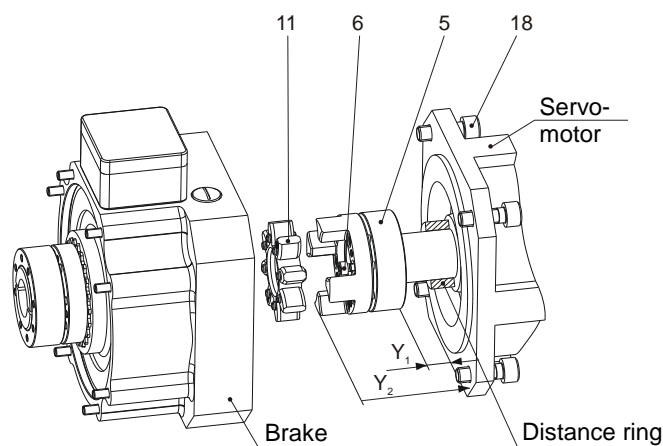

Fig. 33

10.11 Electrical Connection

10.11.1 Terminal box

Component examples in the terminal box (15)

- Terminal
- Release monitoring
- Plug etc.

DANGER Contact with voltage-carrying components.



Electrical shock possible.

Only trained personnel should carry out the connection.

Terminal box (15) with release monitoring (see also section 10.12)

10.11.1.1 Release Monitoring / Proximity Switch

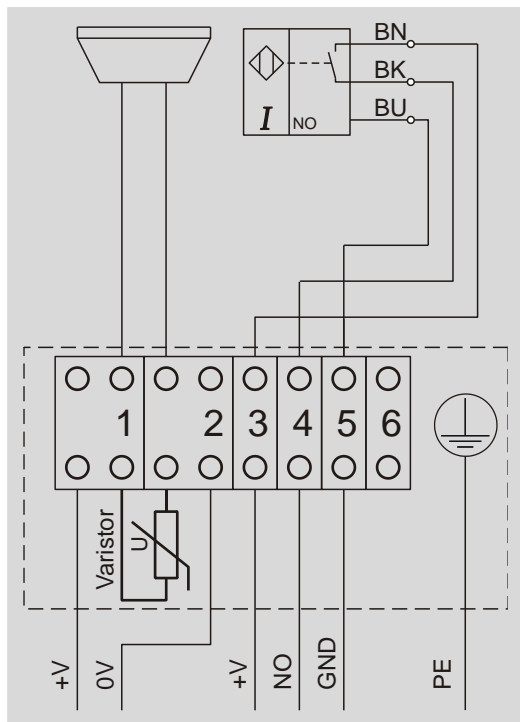

Schematic wiring diagram 6

Connect the protective conductor PE (yellow-green) with a 4 mm lug at the marked connection point.

10.11.1.2 Release Monitoring / Microswitch

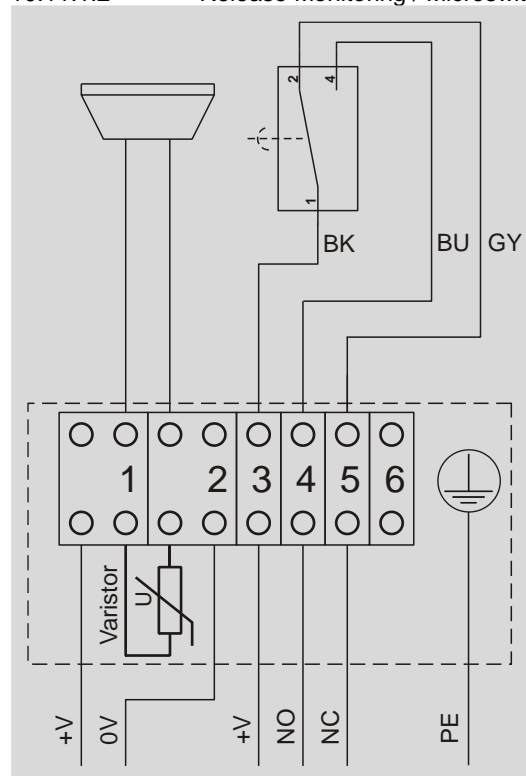

Schematic wiring diagram 7

Connect the protective conductor PE (yellow-green) with a 4 mm lug at the marked connection point.

Varistor:

Possible protection circuit manufacturer-side or customer-side as in section **7.5**

10.11.2 Plug

The electrical connection is produced by inserting the device connector (15) with its counterpart.



Observe pin assignment!

Pin Assignment

- Pin 1: Coil input +
- Pin 2: Coil output -
- Pin 3: Proximity switch BN+
- Pin 4: Proximity switch BK (NO)
- Pin 5: Proximity switch BU-
- Pin PE: Grounding

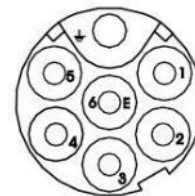

10.12 Release Monitoring

10.12.1 General



Installation, adjustment and de-installation only relevant for replacement.



Proximity switches are subject to a failure rate. For the release monitoring device on ROBA®-topstop® brakes, a proximity switch with a very high reliability and a high MTBF value (Mean Time Between Failure) is used.

Proximity switches are components according to IEC60947-5-2 and are to be used according to the standard. They are electrically specified for applications in well protected (controlled) operating environment (par. 8.2.6). The power supply must be selected accordingly. Additional measures, such as separate cable routing and shielded cables, may be necessary for EMC-compliant installation in machines and systems, especially for long cables.



Microswitches cannot be guaranteed fail-safe. Therefore, please ensure appropriate access for replacement or adjustment.

The switching contacts are designed so that they can be used for both small switching powers and medium ones. However, after switching a medium switching power, small switching powers are no longer reliably possible. In order to switch inductive, capacitive and non-linear loads, please use the appropriate protection circuit to protect against electric arcs and unpermitted loads!



The functional inspection with the stated dimensions only applies within a temperature range of 10 – 35 °C.

10.12.2 Release monitoring with proximity switch

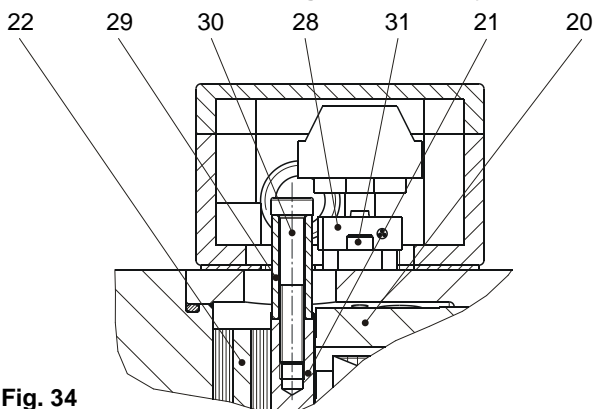

Fig. 34

ROBA®-topstop® brakes are supplied as a standard product with manufacturer-side set release monitoring.

A proximity switch (Item 28) emits a signal for every brake condition change.

Plausibility check

Brake opened	Brake ener-gised	Signal „HIGH“
Brake closed	Brake de-ener-gised	Signal „LOW“

The customer is responsible for a signal evaluation of both conditions (→ see **4.2.3** Release Monitoring/ Signal Evaluation).

Technical Data	
Operating voltage:	10... 30 VDC
Residual ripple content:	≤ 10 % U _{SS}
DC rated operating current:	≤ 150 mA
No-load current I ₀ :	≤ 15 mA
Residual current:	≤ 0.1 mA
Rated insulation voltage:	≤ 0.5 kV
Short-circuit protection:	yes / synchro-nising
Line voltage drop at I _e :	≤ 1.8 V
Wire breakage protection / reverse voltage protection:	yes / completely
Output function:	3-wire, NO contact, PNP
Switching frequency:	≤ 2 kHz

Proximity Switch (28) Wiring Diagram:

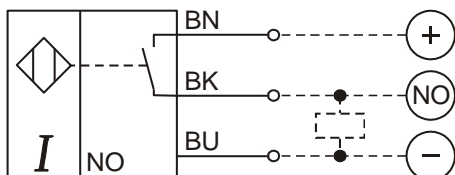

Function

When the magnetic coil is energised in the coil carrier (20), the armature disk (21) is attracted to the coil carrier (20), a proximity switch (28) emits a signal, the brake is released.

WARNING Load crash possible



On drives with gravity-loaded axes, the drive-brake must be load-free. Unless further reliable holding devices prevent lowering of the axis, the axis must be positioned in a safe, low position or supported.

WARNING Contact with voltage-carrying components.



Electrical shock possible. De-energise the brake.

De-installation

1. Open the terminal box lid.
2. Disconnect the connection cable
3. Unscrew the cap screw (31) and remove the proximity switch (28)

Installation and adjustment (only for replacement)

4. Apply the proximity switch (28) assembly incl. the adaptor plate lightly using two cap screws (31) so that the proximity switch (28) can still be moved.
5. See the sticker on the proximity switch connection cable for the precise dimension of the adjustment plate.
6. Insert the adjustment plate between the proximity switch (28) and the switching bolt (29).
7. Press the proximity switch (28) against the adjustment plate and the switching bolt (29) and secure it using the two cap screws (31). Please observe the tightening torque of 2.9 Nm.
8. Remove the adjustment plate.
9. Mark both cap screws (31) on the screw head using sealing lacquer.

Functional Inspection

10. Connect the proximity switch testing device (e. g. 1-1350/ Pepperl+Fuchs GmbH).

Feeler gauge thickness [mm]	Size					
	100	120	150	175	200	260
Thin	0.12	0.15	0.15	0.18	0.20	0.20
Thick	0.16	0.20	0.20	0.22	0.25	0.25

11. Insert the feeler gauge "Thin" mm between the rotor (22) and the armature disk (21) (energise the brake for a short period of time).
12. Energise the brake → Signal "HIGH"
De-energise the brake → Signal "LOW"
Remove the feeler gauge.
13. Insert the feeler gauge "Thick" mm between the rotor (22) and the armature disk (21) (energise the brake for a short period of time).
14. Energise the brake → Signal "HIGH"
De-energise the brake → Signal "HIGH"
Remove the feeler gauge.
15. Connect the brake electrically.
16. Close the terminal box with the lid.

Customer-side Inspection after Attachment

Please inspect the release monitoring:
Brake de-energised → Signal " LOW"
Brake energised → Signal " HIGH"

10.12.3 Release monitoring with microswitch

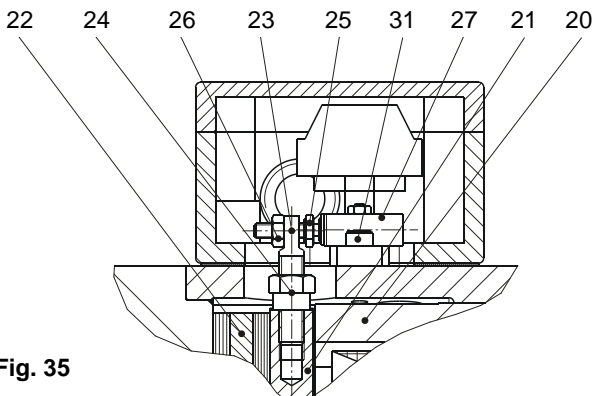

Fig. 35

ROBA®-topstop® brakes are supplied as an option with manufacturer-side set release monitoring with microswitch.

A microswitch (Item 27) emits a signal for every brake condition change.

Plausibility check

Brake opened	Brake ener-gised	Signal "ON"
Brake closed	Brake de-ener-gised	Signal "OFF"

The customer is responsible for a signal evaluation of both conditions (→ see **4.2.3** Release Monitoring/ Signal Evaluation).

Technical Data	
Characteristic values for measurement:	250 V~ / 3 A
Minimum switching power:	12 V, 10 mA
Recommended switching power for maximum lifetime and reliability	DC-12
	24 V, 10...50 mA
	DC-13 with free-wheeling diode!

Microswitch Wiring Diagram (27):

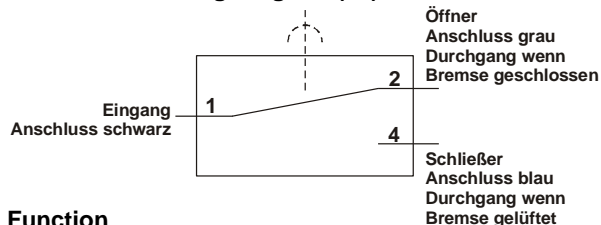

Function

When the magnetic coil is energised in the coil carrier (20), the armature disk (21) is attracted to the coil carrier (20), a microswitch (27) emits a signal, the brake is released.

Usage category acc. IEC 60947-5-1:
DC-12 (resistance load), DC-13 (inductive load)

WARNING Load crash possible



On drives with gravity-loaded axes, the drive-brake must be load-free.
Unless further reliable holding devices prevent lowering of the axis, the axis must be positioned in a safe, low position or supported.

WARNING Contact with voltage-carrying components.



Electrical shock possible.
De-energise the brake.

De-installation

1. Open the terminal box lid.
2. Disconnect the connection cable
3. Remove the microswitch

Installation and adjustment (only for replacement)

4. Secure the microswitch (27) assembly with the adaptor plate in the terminal box.
5. Turn the hexagon head screw (25) in the direction of the switch (27) up to contact on the microswitch tappet.
6. Join a feeler gauge 0.15 mm (loose sensor plate) between the switch tappet (27) and the hexagon head screw (25).
Please make sure that the switch tappet is straight.
7. Turn the hexagon head screw (25) in the direction of the switch (27) up to the signal "ON", turn it back to the signal "OFF", counter the hexagon head screw (25) with the hexagon nut (26) using Loctite 270.

Functional Inspection

8. Connect the inspection or measuring device (diode inspection) to the NO contact black/blue.
9. Energise the brake → Signal "ON"
De-energise the brake → Signal "OFF"
Re-adjust if necessary and repeat the inspection.
10. Inspect using feeler gauge 0.15 mm
Brake energised → Signal "ON",
Brake de-energised → Signal "OFF"
11. Inspection with feeler gauge (loose sensor plate) 0.20 mm
Brake energised → Signal "ON",
Brake de-energised → Signal "ON"
12. Connect the brake electrically.
13. Close the terminal box lid.

11 Initial Operation

11.1 Function Test

After completed assembly and electrical connection of the brake:

- Functional inspection of the proximity switch, section **10.12.2**
- Functional inspection of the microswitch, section **10.12.3**

11.2 Brake Test (Static)

CAUTION During the Brake Test danger to personnel and damage to machines cannot be ruled out in case of malfunctions (incorrect installation, control errors etc.).



Do not enter the danger zone.
Possibly take measures for catching or damping the load.



Recommendation acc. the Division Information Sheet "Gravity-loaded axes – (Vertical axes)" DGUV

- For Category 2 (single-channel), a test torque of at least 1.3 times the load torque is recommended.
- If several brakes are applied in a parallel manner, (e.g. two brakes) this is considered to be fulfilled if the braking devices are tested separately one after the other on the simple weight load (= maximum loading condition).



- The brake test may only be performed in a safe axis position.
- The level of the test torque and the test frequency must be specified by the machine manufacturer.
- Take the test torque into account when dimensioning the brake.

When carrying out control-integrated brake tests, depending on the application, ensure a coordinated permissible rotation angle and a correct level of test torque:

- The permissible angle of rotation for the brake test, which is parameterized in the controller, must be equal to or greater than the sum of the following rotation angle:

Calculation	Explanation
Flexibilities in the system	Rotation angle caused by the system stiffness from the encoder to the brake with applied test torque
+ Backlash brake	Rotation angle over the entire gearing and brake backlash
+ 5 ° Rotation of the rotor	Required for the friction value buildup for the braking torque
≥ permitted rotation angle	Diagnostic rotation angle for abort criteria brake test

Test torque

- $M_{Test} > M_L \times s$
- $M_{Min} > M_{Test} \times 1.25$

Name	Explanation
M_L	Load torque on system
s	Safety factor 1 - 1.3 (see DGUV ²⁾ or normative regulations)
M_{Test}	Test torque
$M_{Min}^{1)}$	Brake minimum braking torque (observe tolerance data and reduction factor from temperature)
$M_N^{1)}$	Brake braking torque

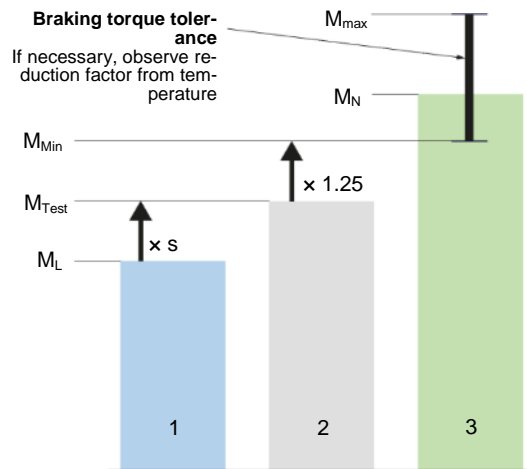

1) Suitable for a brake temperature of 0 up to 60 °C:
 For higher temperatures, account for the following braking torque reduction:
 >60 °C to 80 °C: 10 % reduction

For higher temperatures, please contact mayr® power transmission

2) DGUV: Deutsche Gesetzliche Unfallversicherung (German Statutory Accident Insurance)

Test duration

- Recommendation: Holding time of the test torque e.g. 1 - 5 seconds (test torque must act on the brake at full torque)

Smooth test torque rise (no impact-like test torque initiation)

Brake test result	Measure
Brake test OK	No more measures required
Brake test not OK	<input type="checkbox"/> Inspection application for errors <input type="checkbox"/> Brake inspection <input type="checkbox"/> If necessary, conditioning of the friction pairing by dynamic braking <input type="checkbox"/> Repeat brake test

Definition of static braking torque

Name	Explanation
Quasi-static braking torque (M_N)	Braking torque with slowly slipping brake (1 m/s) at 20 °C (Serves to determination the nominal torque of the brake)
Static braking torque (M_{Test})	Breakaway torque to rotate the motor shaft from standstill when the brake is closed

11.3 Brake Test (Dynamic)



Recommendation

Determine the braking distance in a brake test during idling. The braking distance → EN ISO 13855/EN ISO 13849-2. This test also determines the maximum movement speed and the respective load masses.

The determined braking distance must be shorter than the distance to the stop area. A brake test must ensure that, prior to reaching the stop area, the brake is stopped. The prerequisite for this is the minimum distance to the stop area.

Caution



Please observe the own weight of the brake

The brake may drop during transport / assembly. The consequences may be crush injuries and impact injuries.

For Size 260, use an eyebolt for lifting aids.

WARNING



Load crash possible

The brake loses its braking torque

- During the wear test
- During disassembly of the brake from the machine
- When opening the shaft connection between the machine and the brake
- During energisation of the magnetic coil, e.g. for rotating the shaft
- During activation of the hand release

Unless further reliable holding devices prevent lowering of the axis, the axis must be positioned in a safe, low position or supported.

12 Maintenance / Inspections

The rotor (22) is designed for strength and wear-resistance, which ensures a high brake service lifetime. The rotor (22) is subject to functional wear, which is dependent on the brake application conditions, e.g. it is worn by high total friction work. The brake function (release) can then no longer be guaranteed; however, the braking torque remains. The brake can be re-set to its functional state via rotor replacement.

The rotor toothing is subject to backlash and guarantees the axial displacement capability of the rotor. The rotor (22) is highly overdimensioned to prevent breakage. Due to high-frequency vibrations and impacts through the drive, the toothing may be subject to unpermittedly high wear. This can lead to breakage of the toothing and therefore to a loss of braking torque. The dangerous failure can only be revealed through a static brake test.



Application Test

Measure	Condition	Interval	Implementation
Noise inspection	After initial operation of the machine, check the idling response of the brake for particular noise generation (toothing knock-out possible)	Determine the maintenance and inspection intervals based on the results. ► Please contact <i>mayr</i> ®.	Qualified personnel
	Test the respective application for possible wear, e.g. through a type inspection.		

Operational Instructions for ROBA®-topstop® Type 899_._._._._ Size 100 - 260

(B.899.EN)

Inspection

Visual inspection	Carry out a visual inspection of the brake from the outside for oil contamination. The brake housing should be dry on the outside. In case of heavy contamination with oil, a braking torque reduction through penetration of oil or grease cannot be ruled out.	<ul style="list-style-type: none"> Oil contamination 	To be determined by machine operator depending on the installation situation ► Please contact <i>mayr</i> ®.	Qualified personnel	
<table border="1" style="width: 100%; background-color: #ffff00;"> <tr> <td data-bbox="344 539 504 752" style="text-align: center;"> WARNING  </td> <td data-bbox="504 539 1019 752"> Load crash possible In case of heavy contamination with oil, a braking torque reduction through penetration of oil or grease cannot be ruled out. Avoid oil contamination </td> </tr> </table>		WARNING 	Load crash possible In case of heavy contamination with oil, a braking torque reduction through penetration of oil or grease cannot be ruled out. Avoid oil contamination		
WARNING 	Load crash possible In case of heavy contamination with oil, a braking torque reduction through penetration of oil or grease cannot be ruled out. Avoid oil contamination				

Maintenance

Measure	Note/Comment	Interval	Implementation
Rotor (22) with friction lining (plastic component) without cyclical brake test	Replacement (send the brake to the manufacturer)	After 6 years	mayr® power transmission
Check the shaft-hub connection or integrate it into the maintenance plan of the machine operator.	Check the screw tightening torques Tightening torques see section 4.5	Every 2 years	Qualified personnel
Check the fastening to the motor and machine	Check the screw tightening torques Tightening torques see section 4.5	Every 2 years	

13 Information on the Components

The **friction material** contains different inorganic and organic compounds, which are integrated into a system of hardened binding agents and fibers.

Possible hazards:

No potential dangers have been recognized so far when the brake is used according to its intended purpose. When conditioning of the friction lining pairing (new condition) and also in case of EMERGENCY STOP braking actions, functional wear can occur (wear on the friction linings). On open brake designs, fine dust can be emitted.

Classification: Hazardous property

Attention: H-classification: H372



13.1 Protective measures and rules of behavior:

- Do not inhale dusts
- Vacuum the dusts at the point of origin
- Pre-requisites for the suction device**
 - tested suction devices,
 - tested filters acc. DIN EN 60335-2-69 for dust classes H;
 - maintenance of the suction devices
 - filter replacement at regular intervals
- If local dust suction is not possible or is insufficient, the entire work area must be ventilated using appropriate technology.

Additional information:

This friction lining is not a dangerous product in terms of the EC Directive

14 Cleaning the Brake



Do not clean the brake using compressed air, brushes or similar devices!

- Wear safety gloves / safety goggles
- Use a suction system or wet towels to clean off the brake dust.
- Do not inhale brake dust
 - In case of dust formation, a dust mask FFP 2 is recommended.

15 Wear Inspection



The permitted friction work values (section 5.4) dependent on the switching frequency must not be exceeded, not even in EMERGENCY STOP operation.

WARNING Load crash possible



On both variations, no braking effect is provided during the wear test.
The axis must be secured against dropping.

The wear on the rotor (22) can be checked as follows:

Variant 1: Air gap

On unfavourable axial position of the rotor (22), exact determination of dimension X is not possible.

1. On the energised brake, remove one screw plug (35) positioned at the side
2. Check the dimension X between the rotor (22) and the armature disk (21) using the feeler gauge.

If the max. dimension X is exceeded (acc. table in section 4.5), rotor replacement or complete maintenance must be carried out at the **mayr**® place of manufacture.

Variant 2: Pull-in voltage

Determine the voltage at which the brake first releases. To do this, the brake must be at room temperature.

1. On the energised brake, increase the voltage slowly until the brake releases.
2. The determined pull-in voltage must not exceed the max. value acc. table in section 4.5.

If the max. pull-in voltage is exceeded, rotor replacement or complete maintenance must be carried out at the **mayr**® Antriebstechnik place of manufacture.



The voltage on the brake can be substantially lower with long lines.

If neither variant 1 nor variant 2 can be carried out, wear inspection must be carried out at the **mayr**® power transmission place of manufacture.

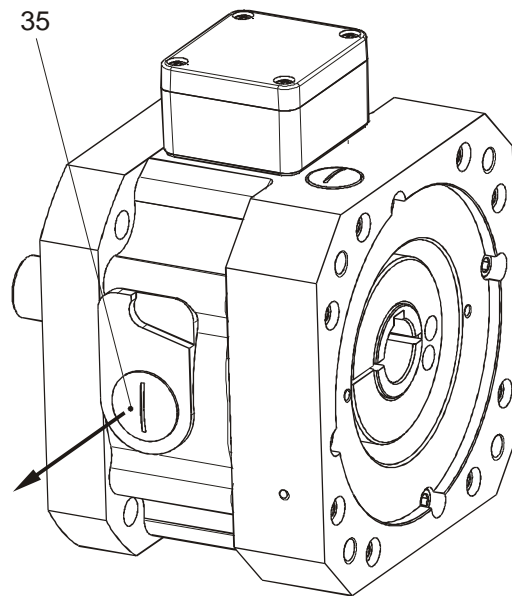

Fig. 36

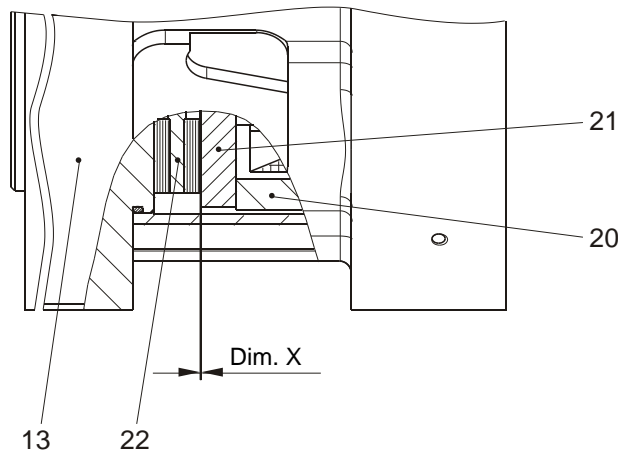

Fig. 37

16 De-installation

CAUTION Please observe the own weight of the brake



The brake may drop during lifting / disassemble. The consequences may be crush injuries and impact injuries.

For Size 260, use an eyebolt for lifting aids.

WARNING Load crash possible



The brake must be load-free.

Please check that it is load-free before de-installation.

- Provide security in the danger zone
- Support the load

Danger Contact with voltage-carrying components.



Electrical shock possible.

Only trained personnel may disconnect the electrical connection.

De-installation takes place by following the "Installation" section **10** backwards.

17 Disposal

Our electromagnetic brake components must be disposed of separately as they consist of different materials. Please also observe the relevant authority regulations. Code numbers may vary according to the disassembling process (metal, plastic and cables).

Electronic components

(Rectifier / ROBA®-switch / ROBA®-brake-checker / microswitch):

Products which have not been disassembled can be disposed of under Code No. 160214 (mixed materials) or components under Code No. 160216, or can be disposed of by a certified disposal firm.

Brake bodies made of steel pads with coil /cable and all other steel components:

Steel scrap (Code No. 160117)

All aluminum components:

Non-ferrous metals (Code No. 160118)

Brake rotor (steel or aluminum pads with friction linings):

Brake linings (Code No. 160112)

Seals, O-rings, V-seals, elastomers:

Plastic (Code No. 160119)

Guidelines on the WEEE Directive 2012/19/EU

Avoidance of waste from electrical and electronic devices and the reduction of such waste through recycling.

Our electromagnetic products (brakes, clutches) as well as the components required to control them (DC voltage modules) are frequently used in electrical and electronic devices within the appropriate area of application of WEEE, independent of the applicable product categories. The stated products do not fall within the area of application of this Directive. They have been classified as electromagnetic / electronic components (VDE 0580) or as electronic equipment (DIN EN 50178), and have been determined for installation in devices for "use in accordance with the intended purpose". Only products which are to be viewed as devices in terms of the Directive and not as parts or components are subject to registration obligations.

18 Malfunctions / Breakdowns

Malfunction	Result of Malfunction	Possible Causes	Solutions	Implementation
			<input type="checkbox"/> The brake must always be dismantled in order to remove damage and malfunctions. <input type="checkbox"/> Damaged parts must be replaced in order to solve the respective problem. <input type="checkbox"/> The brake must be cleaned before re-installation.	
Brake does not release	Wiring error on the brake	Incorrect voltage, no DC voltage	Check voltage, Observe the wiring guidelines	Qualified personnel
		Defective electrical wiring	Check electrical wiring	
		Defective coil, coil is thermally overloaded	Check coil capacity, check insulation resistance	
	Air gap too large in released condition	Worn rotor	Replace rotor or brake	mayr® power transmission
The brake does not release completely; permanent grinding of the rotor	Wiring error on the brake	Incorrect voltage, no DC voltage	Check voltage, Observe the wiring guidelines	Qualified personnel
		Defective electrical wiring	Check electrical wiring	
		Defective coil, coil is thermally overloaded	Check coil capacity, Check insulation resistance	
	Air gap too small in unreleased condition	Penetration of foreign bodies into the brake, in particular magnetisable particles	Check the brake interior for dirt and clean it	mayr® power transmission
		Excessive component temperatures, temperature expansion	Temperature inspection	Qualified personnel

Malfunction	Result of Malfunction	Possible Causes	Solutions	Implementation
			<input type="checkbox"/> The brake must always be dismantled in order to remove damage and malfunctions. <input type="checkbox"/> Damaged parts must be replaced in order to solve the respective problem. <input type="checkbox"/> The brake must be cleaned before re-installation.	
Slipping; permanent grinding of the brake under load; increase in friction work	Braking torque too low	Incorrect dimensioning	Check the required braking torque	Qualified personnel
	Drop in braking torque	Excessive wear on the rotor	Wear test (see section 15)	
	Changes in braking torque	Unpermittedly high friction work, squeaking, type and quality of the counter friction surface	Optimize the electrical control, check the switching times and dimensioning	
		Corrosion on the counter friction surface	Check the brake for corrosion	
		Ambient influences, oil, water, cleaning media, condensation formation	Check protection against environmental influences	
	Excessively long engagement times	Load accelerates the drive line during the brake engagement time	Optimize the electrical control, check the switching times and dimensioning	
	Motor starts up against closed brake	Excessive brake separation times	Optimize the electrical control, check the switching times and dimensioning, check the motor control	
	Loss of spring force	Wire breakage of the spring	Replace the spring	mayr® power transmission
Component breakage	Operating conditions	Oscillations, vibrations, overload, unpermittedly high speeds	Check operating conditions and dimensioning	Qualified personnel



mayr® will take no responsibility or guarantee for replacement parts and accessories which have not been delivered by mayr®, or for damage resulting from the use of these products.

19 Declaration of Conformity

EC – Declaration of Conformity

Translation

In accordance with the directives marked in the following list, we

**Chr. Mayr GmbH + Co. KG
Eichenstraße 1
D-87665 Mauerstetten**

explain in sole responsibility that the listed products meet the requirements

X	EC-Machinery directive 2006/42/EC
	EU-Low voltage directive 2014/35/EU (is covered by the machinery directive where applicable)
	Electromagnetic compatibility directive 2014/30/EU
X	EU Directive on the restriction of the use of certain hazardous substances in electrical and electronic equipment 2011/65/EU (RoHs II) incl. delegated Directive 2015/863/EU amending Annex II of Directive 2011/65/EU (RoHs III)

Electromagnetic safety brake

Product	Sizes	Types	ASRI
ROBA®-topstop®	100 - 260	899_._ _ _ _ _	1,2,4,8

Year of manufacture: see type tag

Applied Standards, Regulations and Inspections (ASRI)

1	DIN VDE 0580	11/2011	Electromagnetic devices and components, general specifications	2014/35/EG
2	DIN EN ISO 12100	03/2011	Safety of machinery - General principles for design	2006/42/EG
4	DIN EN ISO 13849-1	06/2010	Safety of machinery – Safety related parts of control systems	2006/42/EG
8	DIN EN IEC 63000; VDE 0042-12:	2019-05	Technical documentation for the assessment of electrical and electronic equipment regarding the restriction of hazardous substances	2011/65/EU

Representatives name for the documentation: Quality Management

Mauerstetten, July 15, 2020

Ort und Datum / place and date

Dipl. Ing. (FH) / graduate engineer
Geschäftsführer / Managing Director
Günther Klingler

5 UK Declaration of Conformity Roba topstop

See also

 UKCA KE Roba topstop 899_en [▶ 71]

UKCA Declaration of conformity



In accordance with the directives marked in the following list, we

Chr. Mayr GmbH + Co. KG
Eichenstraße 1
D-87665 Mauerstetten

explain in sole responsibility that the listed products meet the requirements

	Supply of Machinery (Safety) Regulations 2008, 2008 No. 1597
X	Electrical Equipment (Safety) Regulations 2016, 2016 No. 1101 (may be covered by 2008 No. 1597)
	Electromagnetic Compatibility Regulations 2016, 2016 No. 1091
X	RoHS Regulations 2012 No. 3032

Brakes

Product	Type	ASRI
ROBA-stop®	8_.....	20,21,22
ROBA-stop® S	856.41_..	20,21,22
ROBA-stop®-B	893.0_..	20,21,22
ROBA-stop®-M	891_.....	20,21,22
ROBA-stop®-silenzio®	896_.....	20,21,22
ROBA-stop®-Z	892_.....	20,21,22
ROBA®-alphastop®	897_.....	20,21,22
ROBA®-diskstop®	894_.....	20,21,22
ROBA®-duplostop®	8010_.....	20,21,22
ROBA®-secustop®	8020_.....	20,21,22
elevstop®	8_14_.....	20,21,22

Product	Type	ASRI
ROBA®-topstop®	899_.....	20,21,22
ROBA®-topstop®	899_.....	20,21,22
ROBA-stop® twin	895_.....	20,21,22
ROBA®-quatrostop®	8040_.....	20,21,22
ROBA®-twinstop®	8012_.....	20,21,22
ROBA®-boxerstop	8013_..... 3	20,21,22
ROBA®-linearstop	382.0_.....	20,21,22
ROBA®-linearstop	382_0_.....	20,21,22
ROBA®-servostop	898_.....	20,21,22
ROBA®-servostop	898_.....	20,21,22

Applied standards, regulations and inspections (ASRI)

20 DIN EN IEC 63000	2019-05	Technical documentation for the assessment of electrical and electronic equipment with regard to the restriction of hazardous substances	2012 No. 3032
VDE 0042-12			
21 EN 60529	2013	Degrees of protection provided by enclosures (IP Code)	2016 No. 1101
22 DIN EN 61140	2016-11	Protection against electric shock - Common aspects for installation and equipment	2016 No. 1101

Documentation kept by (for UKCA only): Mr. Andrew Nicoll	Authorised representative and importer contact details: Mayr Transmissions Ltd. Valley Road, Keighley, West Yorkshire, BD21 4LZ www.mayr.com
For the manufacturer: _____ Mauerstetten, 09.11.2022 _____ Ort und Datum / place and date	 _____ Geschäftsführer / Managing Director Ferdinand Mayr M.Sc.
For the representative of the manufacturer / importer: _____ West Yorkshire, 09.11.2022 _____ Ort und Datum / place and date	 _____ Geschäftsführer / Managing Director Andrew Nicoll

6 Roba switch operating manual

See also

 [BAL roba switch 017-00-2_en \[▶ 73\]](#)



Guidelines on the Declaration of Conformity

A conformity evaluation has been carried out for the product in terms of the EC Low Voltage Directive 2014/35/EC and the EMC Directive 2014/30/EU. The Declaration of Conformity is laid out in writing in a separate document and can be requested if required.

Guidelines on the EMC Directive (2014/30/EU)

The product cannot be operated independently according to the EMC directive. Only after integration of the product into an overall system can this be evaluated in terms of the EMC. For electronic equipment, the evaluation has been verified for the individual product in laboratory conditions, but not in the overall system.

Guidelines on the Machinery Directive (2006/42/EC)

The product is a component for installation into machines according to the machinery directive 2006/42/EC. The product can fulfil the specifications for safety-related applications in coordination with other elements. The type and scope of the required measures result from the machine risk analysis. The product then becomes a machine component and the machine manufacturer assesses the conformity of the safety device to the directive. It is forbidden to start use of the product until you have ensured that the machine accords with the regulations stated in the directive.

Guidelines on the ATEX Directive

Without a conformity evaluation, this product is not suitable for use in areas where there is a high danger of explosion. For application of this product in areas where there is a high danger of explosion, it must be classified and marked according to directive 2014/34/EU.

Safety and Guideline Signs

DANGER



Immediate and impending danger, which can lead to severe physical injuries or to death.

CAUTION



Danger of injury to personnel and damage to machines



Guidelines on important points

General Safety Guidelines

DANGER



Danger of death! Do not touch voltage-carrying lines and components.

DANGER



Danger of burns when touching hot surfaces

CAUTION



- Danger from devices caused by short-circuits and earth short-circuits at the terminals
- Electronic devices cannot be guaranteed fail-safe.

During the risk assessment required when designing the machine or system, the dangers involved must be evaluated and removed by taking appropriate protective measures.

To prevent injury or damage, only professionals and specialists are allowed to work on the devices. They must be familiar with the dimensioning, transport, installation, initial operation, maintenance and disposal according to the relevant standards and regulations.

General Safety Guidelines



Only carry out installation, maintenance and repairs in a de-energised, disengaged state and secure the system against inadvertent switch-on.



Before product installation and initial operation, please read the Installation and Operational Instructions carefully and observe the Safety Regulations. Incorrect operation can cause injury or damage.

Installation and Operational Instructions for ROBA®-switch Type 017._00.2

(B.017+002.EN)

Application

ROBA®-switch fast acting rectifiers are used to connect DC consumers to alternating voltage supplies, for example electromagnetic brakes and clutches (ROBA-stop®, ROBA®-quick, ROBATIC®) as well as electromagnets, electrovalves, etc.

Fast acting rectifier ROBA®-switch 017._00.2

- Consumer operation with overexcitation or power reduction
- Input voltage: 100 – 500 VAC
- Maximum output current I_{RMS} : 3 A at 250 VAC
- UL-approved

Function

The ROBA®-switch is used for operation at an input voltage of between 100 and 500 VAC, depending on the size. It can switch internally from bridge rectification output voltage to half-wave rectification output voltage. The bridge rectification time can be modified from 0.05 to 2 seconds by exchanging the external resistor (R_{ext}).

Electrical Connection (Terminals)

- 1 + 2 Input voltage (fitted protective varistor)
- 3 + 4 Connection for external contact for DC-side switch-off (with an installed bridge, switch-off only takes place AC-side with a longer brake engagement time)
- 5 + 6 Output voltage (fitted protective varistor)
- 7 + 8 R_{ext} for bridge rectification time adjustment



Dimensions (mm)

Type 017.000.2

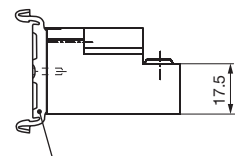
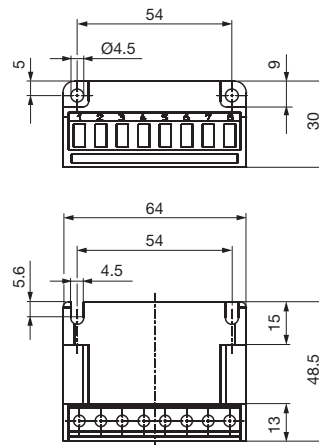





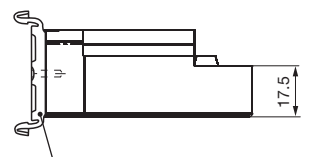
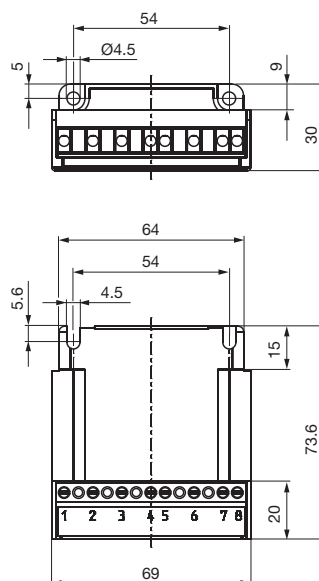



Accessories:
Mounting bracket set for 35 mm rail acc. EN 60715:
Article No. 1802911

Type 017.100.2



Accessories:
Mounting bracket set for 35 mm rail acc. EN 60715:
Article No. 1802911

Technical Data				Type 017.000.2		Type 017.100.2	
				Size 10	Size 20	Size 10	Size 20
Input voltage	$\pm 10\%$ 50 / 60 Hz	U_{AC}	[VAC]	100 – 250	200 – 500	100 – 250	200 – 500
Output voltage	$(= 0.9 \times U_{AC})$	U_{bridge}	[VDC]	90 – 225	180 – 450	90 – 225	180 – 450
	$(= 0.45 \times U_{AC})$	$U_{half-wave}$	[VDC]	45 – 113	90 – 225	45 – 113	90 – 225
Output current	at $\leq 45^\circ C$	I_{RMS}	[A]	2.0	1.8	3.0	2.0
	at max. $70^\circ C$	I_{RMS}	[A]	1.0	0.9	1.5	1.0
Fitted protective varistors		U_{RMS}	[V]	275	550	275	550
Device fuses				FF 5 A (H) 5 x 20 mm	FF 4 A (H) 6.3 x 32 mm	FF 6.3 A (H) 5 x 20 mm	FF 5 A (H) 6.3 x 32 mm
Protection				IP65 components	IP20 terminals	IP10 R _{ext}	
Terminals				Nominal cross-section 1.5 mm ² (AWG 22-14), screws M3, max. tightening torque 0.5 Nm			
Ambient temperature			[°C]	-25 to +70			
Storage temperature			[°C]	-40 to +70			
Conformity markings				 	 up to 300 V 	 	 
Installation conditions				The installation position can be user-defined. Please ensure sufficient heat dissipation and air convection! Do not install near to sources of intense heat!			

Wiring example

(400 VAC, AC-side switching)

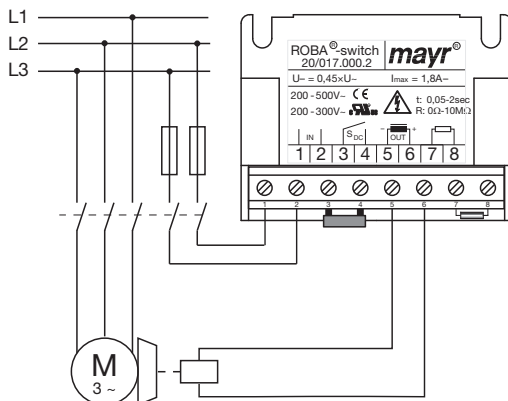

AC-side switching means **low-noise switching**; however, the brake engagement time is longer (approx. 6 – 10 times longer than with DC-side switching), use for non-critical braking times.

Wiring example

(400 VAC, DC-side switching)

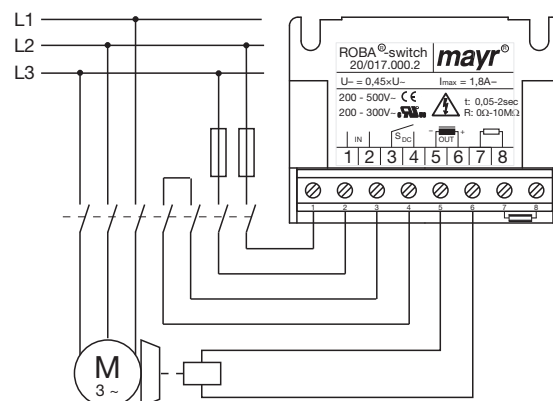

DC-side switching means **short brake engagement times (e.g. for EMERGENCY STOP operation)**; but louder switching noises will occur.

Protection circuit



When using DC-side switching, the coil must be protected by a suitable protection circuit according to VDE 0580, which is integrated in *mayr*®-rectifiers. Nevertheless, the high voltage induced on circuit interruption produces switching sparks, which lead to contact consumption.

Therefore, only use the main contacts of a contactor suitable for inductive loads with a minimum contact opening of 3 mm for switching the DC-side contact S_{DC}. Connecting the main contacts in series reduces wear.

Switch-ON

Switch-on always takes place AC-side, as only then is the overexcitation activated.

Switch-OFF



If short switching times are required, please switch DC-side. The AC-side should always be switched as well, in order to activate the overexcitation.

If a longer brake engagement time or a quieter switching noise is required, please switch AC-side. For this, a bridge must be installed between terminals 3 and 4.

Device Fuses

To protect against damage from short-circuits or earth short-circuits, please add suitable device fuses to the mains cable. As an alternative, a motor protection switch can be used. This must be adjusted to the holding current of the brake; at the same time it serves as overload protection for the brake.

Short-circuits or earth short-circuits occurring during the overexcitation time period can lead to ROBA®-switch failures. After fuse elements have reacted to a malfunction, the ROBA®-switch must be checked for functional and operational safety (overexcitation voltage, switch-off voltage, response delay time, holding voltage).

The same procedure is to be carried out after coil failure.

Overexcitation

On overexcitation, the brake is initially energised with a voltage higher than the nominal voltage. This decreases the separation time t_2 .



Increased wear (enlarged air gap) as well as coil heat-up lengthen the brake separation time t_2 . Therefore, when dimensioning the overexcitation time t_o , please select at least double the separation time t_2 on each brake Type and size (catalogue values).

Different external resistors between terminals 7 and 8 allow the adjustment of different overexcitation times. The overexcitation time has a standard adjustment of $0.45 \text{ s} \pm 20 \%$.

Overexcitation Times

Overexcitation time	External resistors on terminals 7 and 8
t_o	R_{ext}
[s]	[Ω]
0.05	0 (bridge)
0.10	22 K
0.20	82 K
0.45	221 K (standard)
0.69	390 K
0.76	470 K
0.95	680 K
1.15	1 M
1.25	1.30 M
1.53	2.20 M (included)
2.00	10 M
2.15	open

The times printed in bold can be adjusted for delivery. For the other times, please select the respective resistors.

Recovery Time 100 ms

The recovery time is the amount of time the ROBA®-switch requires in order to reach its starting position after switch-off. Therefore, the input voltage may be switched on again at the earliest after 100 ms.

During cycle operation, please take suitable measures to ensure that the recovery time of 100 ms is maintained.

Coil Capacity

The values for the **maximum coil nominal capacity** stated in the Table are guideline values for a switching frequency of maximum 1 cycle per minute and for maintenance of the permitted current I_{RMS} .

Sizes	Input voltage U_{AC} [VAC]	Coil nominal voltage U_N [VDC]	Coil nominal capacity P_N [W]				Operation with	
			Type 017.000.2		Type 017.100.2		over-excitation	power reduction
			≤ 45 °C	70 °C	≤ 45 °C	70 °C		
10	115	104	416	208	624	312		x
		104	208	104	312	156	x	
	230	180	623	312	935	437	x	x
		207	824	412	1236	618		x
20	230	104	187	94	208	104	x	
		180	561	280	623	312	x	x
		207	742	371	824	412		x
	400	180	324	162	360	180	x	
		207	428	214	476	238	x	x
		225	506	253	563	281	x	x
		500	225	405	203	450	225	x



If the switching frequency is larger than 1 cycle per minute or if the overexcitation time t_o is longer than double the separation time t_2 , please observe the following:

$$P \leq P_N$$

The coil capacity P must not be larger than P_N or the nominal current I_{RMS} which flows through the ROBA®-switch must not be exceeded, as otherwise the coil and the ROBA®-switch can fail due to thermal overload.

Time Diagram:

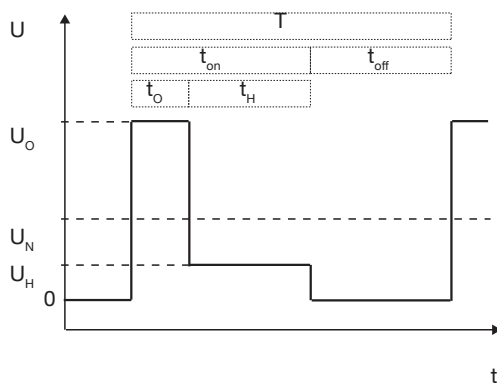

Calculations:

P [W] RMS coil capacity dependent on switching frequency, overexcitation, reduction in capacity and duty cycle

$$P = \frac{P_o \times t_o + P_H \times t_H}{T}$$

P_N [W] Coil nominal capacity (catalogue values, Type tag)

P_o [W] Coil capacity on overexcitation

$$P_o = \left(\frac{U_o}{U_N} \right)^2 \times P_N$$

P_H [W] Coil capacity at reduced capacity

$$P_H = \left(\frac{U_H}{U_N} \right)^2 \times P_N$$

t_o [s] Overexcitation time

t_H [s] Time of operation with reduction in capacity

t_{off} [s] Time without voltage

t_{on} [s] Time with voltage

T [s] Total time ($t_o + t_H + t_{off}$)

U_o [V] Overexcitation voltage (bridge voltage)

U_H [V] Holding voltage (half-wave voltage)

U_N [V] Coil nominal voltage

I_{eff} [A] RMS current dependent on switching frequency, overexcitation time and duty cycle

$$I_{RMS} = \sqrt{\frac{P \times P_N}{U_N^2}}$$

EMC-compatible Installation

The ROBA®-switch does not produce any interference. However, if the device is used in connection with other components (e.g. electromagnetic brakes), the resulting interference can exceed the permitted limit values. Please therefore install the rectifier in accordance with the EMC directives!

The measure described for compliance with the EMC directive is examined under laboratory conditions, and cannot necessarily be bindingly transferred onto the condition of a machine or equipment in case of deviations. The inspection tests the individual components *mayr*®-ROBA®-switch and the *mayr*®-brake and is applicable for an input voltage of up to 500 VAC.

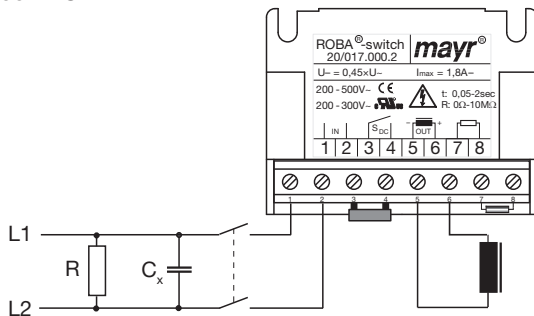

Measure

Installation of a C_x -capacitor into the AC connection:

$C_x = 330 \text{ nF} / 660 \text{ V}$ The voltage resistance of the capacitor must be at least that of the U_{AC} mains voltage!

$R = 0.5 \text{ M}\Omega$ discharge resistor

The C_x -capacitor must be mounted in front of the AC switching contacts!



- Avoid an antennae effect: Keep the supply cables as short as possible; do not form rings or loops with the cables!
- Mount good earth connections onto the metal body of the brake!
- Lay control cables separately from power cables or from strongly pulsating supply cables!

Standards

Product standard

VDE 0160/DIN EN 50178:1998-04

Electronic equipment for use in power installations

EMC inspections

EN 61000-6-2:2006-03

Interference immunity

EN 61000-6-4:2007-09

Interference emission

Insulation coordination

acc. VDE 0110 / EN 60664:2008-01

Overvoltage category III

Pollution degree 2 for Type 017.000.2

Pollution degree 3 for Type 017.100.2

Rated insulation voltage 500 V_{RMS}

Intended Use

mayr®-rectifiers have been developed, manufactured and tested as electronic equipment in compliance with the DIN EN 50178 standard and in accordance with the EU Low Voltage Directive. During installation, operation and maintenance of the product, the requirements for the standard must be observed. *mayr*®-rectifiers are for use in machines, systems and devices and must only be used in the situations for which they are ordered and confirmed. The products are designed for installation into electrical control cabinets and terminal boxes. Using them for any other purpose is not allowed.

7 UK Declaration of Conformity Roba switch

See also

 UKCA KE Roba switch 017-00-2_2022_08_en [[▶ 80](#)]

UKCA Declaration of conformity



In accordance with the directives marked in the following list, we

Chr. Mayr GmbH + Co. KG
Eichenstraße 1

D-87665 Mauerstetten

explain in sole responsibility that the listed products meet the requirements

	Supply of Machinery (Safety) Regulations 2008, 2008 No. 1597
X	Electrical Equipment (Safety) Regulations 2016, 2016 No. 1101 (may be covered by 2008 No. 1597)
X	Electromagnetic Compatibility Regulations 2016, 2016 No. 1091
X	RoHS Regulations 2012 No. 3032

Safety clutches / shaft couplings

Product	Type	ASRI	CE
EAS®-Sm/Zr	4__03__	21,20	3/90

Product	Type	ASRI	CE

Electromagnetic clutches and brakes

Product	Type	ASRI	CE
ROBATIC®	5_____	21,20	3/96
ROBA®-quick	52_____	21,20	3/96

Product	Type	ASRI	CE
ROBA®-takt	67_0_0	21,20	3/96
ROBA®-takt	65_0_0	21,20	4/2020

Electrical accessories, electronic control

Product	Type	ASRI	CE
Limit switch mechanical, adjustable	055.000.5	20,22	8/96
Limit switch mechanical, multi-directional	055.010.6	11,12,20	3/00
Limit switch contactless	055.00_5	3,8,9,20	8/99
Limit switch contactl. + Flange	055.012.6	13,20	6/06
Limit switch contactl./ magnetic	055.009.6	13,20	8/96
EAS®-Sm/Zr switch gear	010.000.2	3,8,9,20	8/99
EAS®-Sp control unit	090.000.2	8,9,20,22	10/99
Rectifier	02_____6	3,8,9,20	4/99
Phase demodulator	012.00_2	3,8,9,20	3/02
ROBA®-switch	017_____2	3,8,9,20	2/01
ROBA®-switch 24V	018__00.2	8,9,20,22	4/07

Product	Type	ASRI	CE
ROBA®-multiswitch	019__00.2	3,8,9,20	10/07
Spark absorber	070.000.6	3,20	7/03
ROBA®-takt switch gear	014.000.2	3,8,9,20	1/96
ROBA®-takt circuit module	004.000__	8,9,20,22	1/96
ROBA®-DSM	971____5_	14-18,20	8/15
ROBA®-brake-checker plus DC	028__00.2	8,9,19,20	6/15
ROBA®-brake-checker plus AC	029.700.2	3,8,9,20	3/18
ROBA®-brake-checker AC	059.500.2	3,8,9,20	2/18
ROBA®-torqcontrol	068.200.2	2,3,20	5/18
ROBA®-brake-checker DC	058.600.2	8,9,20	11/19
release monitoring	056.000.2	8,9,20	11/19

Motors and controllers

Product	Type	ASRI	CE
tendo® PM (>50VAC/75VDC)	M/K1	5,20	11/96
tendo® PM (all voltages)	M/K1	20	07/19

Product	Type	ASRI	CE

UKCA Declaration of conformity



Applied standards, regulations and inspections (ASRI)

3	DIN EN 50178 (VDE0160)	04/1998	Electronic equipment for use in power installations	2016 No. 1101
4	DIN EN 60664-1	01/2008	Specification for high-voltage fuse-links for motor circuit applications	2016 No. 1101
5	DIN EN 60034-1 (VDE0530)	01/2015	Rotating electrical machines, Rating and performance	2016 No. 1101
8	DIN EN 61000-6-2	05/2016	Electromagnetic compatibility, immunity for industrial environments	2016 No. 1091
9	DIN EN 61000-6-4	04/2017	Electromagnetic compatibility, emission stand. for industrial environments	2016 No. 1091
11	DIN EN 60947-5-1	04/2010	Control circuit devices and switching elements	2016 No. 1091
12	DIN EN 60947-1	10/2011	Low-voltage switchgear and control gear: General rules	2016 No. 1091
13	DIN EN 60947-5-2	01/2014	Low-voltage switchgear, control gear and proximity switches	2016 No. 1091
14	DIN EN 61326-1	07/2013	Electrical equipment for measurement, control and laboratory	2016 No. 1091
15	DIN EN 55011	2009+10	Industrial, scientific and medical equipment - Radio frequency disturbance	2016 No. 1091
16	DIN EN 300440-1	04/2011	Electromagnetic compatibility and Radio spectrum Matters (ERM)	
17	DIN EN 300440-2	04/2011	Electromagnetic compatibility and Radio spectrum Matters (ERM)	
18	DIN EN 301489-3	12/2013	Electromagnetic compatibility and Radio spectrum Matters (ERM)	
19	DIN EN 61000-6-3	09/2011	Generic standards- Emission standard for residential, commercial...	2016 No. 1091
20	DIN EN IEC 63000 VDE 0042-12	2019-05	Technical documentation for the assessment of electrical and electronic equipment with regard to the restriction of hazardous substances	2012 No. 3032
21	DIN EN 60529	2014-09	Degrees of protection provided by enclosures (IP Code)	2016 No. 1101
22	DIN EN 61140	2016-11	Protection against electric shock - Common aspects for installation and equipment	2016 No. 1101

Dokumentationsbeauftragter / Documentation keep by (for UKCA only): <p style="text-align: center;">Mr. Andrew Nicoll</p>	Authorised representative and Importer contact details: <p style="text-align: center;">Mayr Transmissions Ltd. Valley Road, Keighley, West Yorkshire, BD21 4LZ www.mayr.com</p>
For the manufacturer: Mauerstetten, <u>24.08.2022</u> <small>Ort und Datum / place and date</small>	 <small>Geschäftsführer / Managing Director Ferdinand Mayr M.Sc</small>
For the representative of the manufacturer / importer: West Yorkshire, <u>29.08.2022</u> <small>Ort und Datum / place and date</small>	 <small>Geschäftsführer / Managing Director Andrew Nicoll</small>

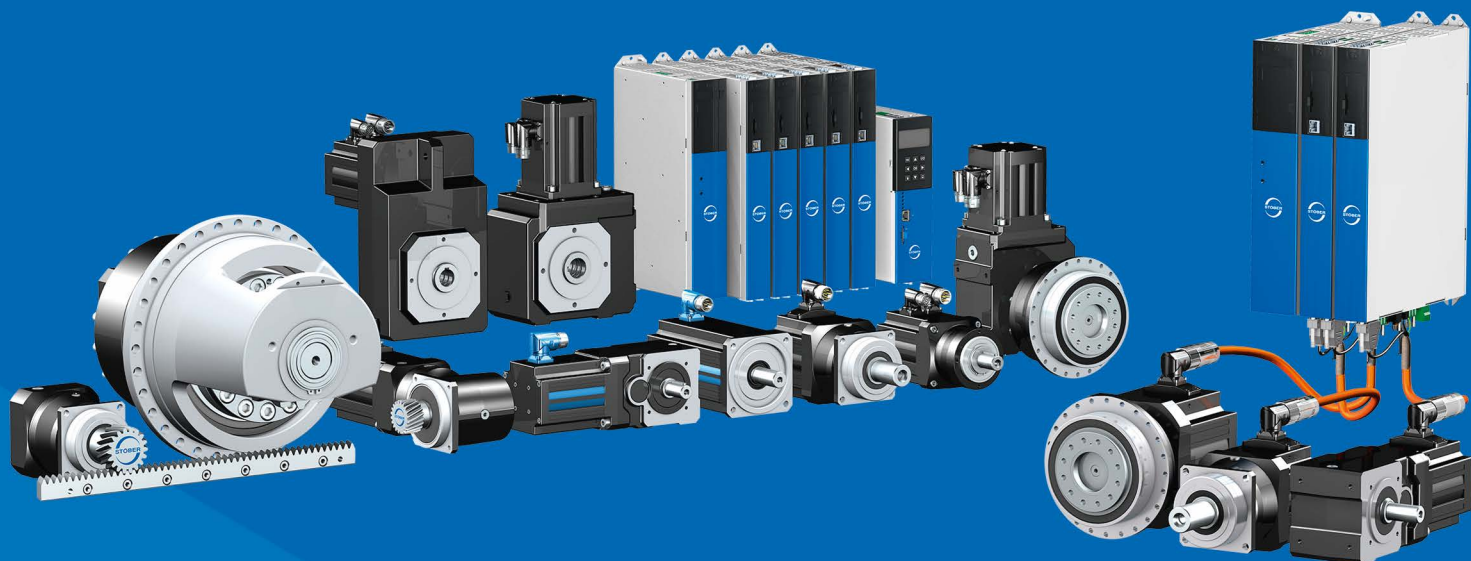

443287_en.03

01/2024

STÖBER Antriebstechnik GmbH + Co. KG
Kieselbronner Str. 12
75177 Pforzheim
Germany
Tel. +49 7231 582-0
mail@stoerber.de
www.stober.com

24 h Service Hotline
+49 7231 582-3000



STÖBER

www.stober.com