

PK Series: RIGHT ANGLE – Shaft Output

PK Features

- 4:1 to 561:1 ratios (higher ratios available. Contact STÖBER.)
- Quiet running (<63dB(A))
- Bearing options to suit your application needs, extending gearbox life and avoiding oversizing, (see page 209).
- Error free motor mounting and quick changeover with toleranced pilot on motor plate
- Low no load running torque, giving you more torque for your application
- Magnetic oil filtration to remove contaminants to prevent breakdowns
- Build and ship in one day
- Assembled in the USA

STÖBER PK provides a right angle option with planetary gearing. It is a more compact, precise solution and can handle higher input speeds. Every gearbox is made to order. STÖBER will custom whatever you need to fit your application. Contact us today to learn more.

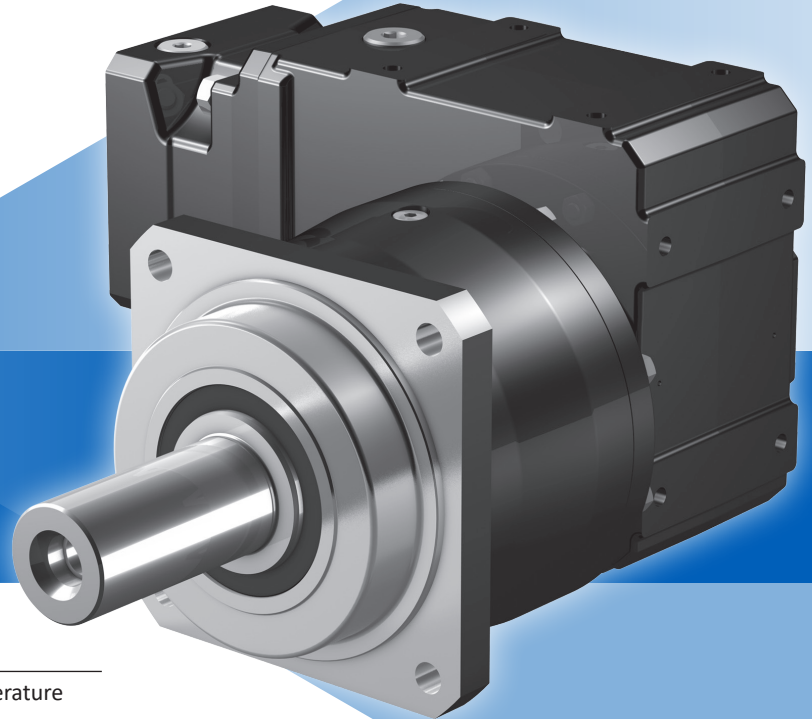

**SHIPS in
1 DAY!**
NO EXPEDITE FEE FOR 24
HOUR SERVICE

General Specifications

Ambient Temperature	0°C to +40°C (104°F) [Unit temperature <90°C Max]
Backlash	PK ≤3.5 (see performance overview chart, page 186)
Coating	Standard Black (RAL-9005), Corrosion Resistant option, Food option
Degree of Protection	IP65
Direction of Rotation	PK: Input and output rotate the SAME direction
Efficiency	PK 94%
Input RPM	Up to 6,000 RPM
Installation	Requires 12.9 fasteners. See page 288, for more information
Lubrication	Lubricated for life – standard Mobil SHC629; option food grade Mobil SHC CIBUS 150
Mounting Position	Must be specified, see page 188
Warranty	5 Year Limited (2 Years on normal wear items: bearings, seals, etc.)

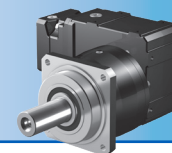

Overview



Selection Options At-a-Glance

Using the **Selection Data** table later in this section, select the PK Series Gearhead with the appropriate performance and design options tailored to your motor choice and exact application requirements. Use the part number guide below as a reference to build a part number for the complete gearhead assembly.

Part Number Examples:

PK 1 2 3 4 5 6 7 8 9 0 ! @ # *

PK P 5 3 1 S P S S 0030 K102VF 0040 ME10 F EL1*

Design Option	Part Number Code	Description
1 Series	P	Planetary
2 Size	5 7 8 9	4 sizes of gearhead
3 Generation	3	Version of gearhead
4 # of Stages	1	One stage for ratios of ≤ 10:1
5 Housing	S	Standard mounting style
6 Output Shaft	P G	Shaft with key Plain shaft (no key)
7 Bearing Options	 S	Ball bearing
	 D	Double row angular contact bearing
	 Z	Cylindrical roller bearing ("Z" cylindrical roller bearing not allowed with reduced backlash option.)
8 Backlash	S R	Standard Backlash Reduced Backlash
9 Ratio	0030	Ratios range from 3:1 to 100:1 for PK Series (0030=3:1; 0160=16:1; 1000=100:1, ect.)
0 Secondary Unit	K102VF	K Series helical/bevel unit: 4 sizes, 2 stages, with output shaft (V) & flange (F) – please specify side 3 or side 4 (see page 188 for more information)
! Secondary Unit Ratio	0040	Ratios from 4:1 to 69:1 (0010=1:1; 0020=2:1; 0030=3:1)
@ Motor Adapter	ME10 - ME40	Motor Adapter with EasyAdapt coupling
# Special Options	F	Food Duty (Size P5 only)
* Mounting Position	EL1 EL2 EL3 EL4 EL5 EL6	Required special instruction for all units, see page 188

PK Series: RIGHT ANGLE – Shaft Output

Options

ME Adapter Option

- MSS1 Seal – special input seal for longer life (For sizes P5-9). Contact factory for this option.
- Peak Torque Booster – pinion securing element for shock loads, increasing peak torque up to 80%.

Integrated Safety Brake

- ServoStop – provides dynamic braking during power failures or emergency stops in hazardous situations. Contact factory for this option.

Coating Option

- **Standard:** For dry areas and normal conditions. All units standard coating, unless ordered with Food Duty.
- **Food Duty:** Able to withstand severe wet areas and washdown application (Size P5 only).
- Available with multi-layer, industrial 316 stainless steel epoxy coating. Contact factory for this option.

PK Series: RIGHT ANGLE – Shaft Output

PK Series Performance Overview

PK Series performance is dependent on several factors including duty cycle, bearing design, gearhead size and stage configuration, among others. Use the chart below for preliminary evaluation, then use the following performance chart and selection information on the following pages for specific performance sizing and selection.

Size/Generation/# of Stages		P531	P731		P831		P931
Secondary Unit		K1	K1	K2	K2	K3	K4
Acceleration Torque M_{2BMAX}	N	350	805		1494	1840	3105
Output Torque Nom. ¹⁾ M_{2N}	N	220	440		1000	1100	2100
Torsional Stiffness C_2	Nm/arcmin	29	53		131	128	305
Torsional Backlash ²⁾ $\Delta\phi$	standard	≤4	≤3.5	≤4	≤3.5	≤4	≤3.5
Reduced Backlash		≤2.0	≤1.5	≤2.0	≤1.5	≤2.0	≤3.5
Input Speed Max. n_{1MAX}	Continuous	4000	4000	4000	4000	3900	3600
	Cyclic	7000	7000	6500	6500	6000	5500
Efficiency (@ nom torque)	%	94	94		94		94
Weight	kg	17.5	24.2	31.7	49.1	54.1	84.4
	lbs	38.5	53.2	69.7	108	119	185.7
Noise ³⁾	dB(A)	≤63	≤63	≤64	≤64	≤65	≤66

Performance by Bearing Design Option ⁴⁾

S = Ball bearing D = Double row angular contact bearing Z = Cylindrical roller bearing ⁵⁾

		P5	P7	P8	P9
Axial Load F_{2ax100}	S	2300	2900	4700	6000
	D	6000	10,000	15,500	25,000
	Z	1600	2000	3600	5000
Radial Load Max $F_{2rad100}$	S	6500	8500	13,000	18,000
	D	7000	9500	15,000	20,000
	Z	8000	10,000	18,000	27,000
Tilting Moment Max M_{2K100}	S	315	544	852	1539
	D	382	665	1095	1930
	Z	388	640	1179	2309

¹⁾ Ratings based on input speed (n_1) of 1500 RPM.

To calculate torque at higher input speeds, contact the factory.

²⁾ Tested at 1.5% of nominal torque and recorded on the output side of the gearhead.

³⁾ Measurement at one (1) meter distance with input speed (n_1) of 1500 RPM.

⁴⁾ See page 209 for output bearing options. Rating based on output speed (n_2) of 100 RPM. For values at other speeds see page 190.

⁵⁾ "Z" cylindrical roller bearing not allowed with reduced backlash option.

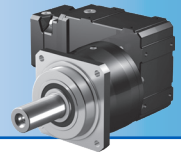

Overview

PK Series Motor Mounting Plate Option (Motor information required with ME or MF Motor Adapter Option)

STÖBER Servo Gearheads fit the motor of your choice with the appropriate motor mounting plate assembled between the motor and the gearhead.

NOTE: When ordering a gearhead:

- Specify the motor manufacturer and part number
- Provide the motor drawing with dimensions, or specify the motor mounting dimensions (per the list shown at right)

For a precise dimension on a specific motor, or for general assistance, we recommend you contact STÖBER Technical Support.

Maximum 10 working days for custom motor mounting plates.

Customer Required Dimensions for Properly Sized Motor Mounting Plate

d2	Motor Shaft Diameter (If an adapter bushing is required it will be supplied with the motor plate.)
b6	Pilot Diameter
e6	Bolt Circle Diameter
s6	Bolt Diameter
l5	Motor Shaft Length
f6	Pilot Length
a6	Square Flange (Optional – motor plate will typically be made to match this dimension.)

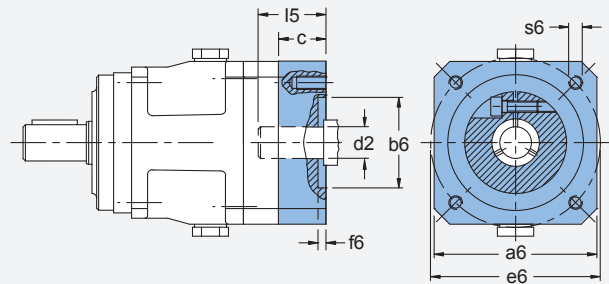

Motor Mounting Plate Dimensions — mm (Gearhead Part Number Specific)

	P532	P431...L P531 P532...L P732	P531...L P731 P732...L P832	P731...L P831 P832...L P932	P831...L P931 P932...L
Maximum Allowed Motor Shaft Dia. d2	24	32	38	48	60
Minimum Allowed Motor Plate Thickness c*	21	24	26	35	43

* Note that c motor plate thickness is determined by the motor shaft length. The minimum motor plate thickness is the value listed.

PK Series Output Shaft Options ("P" or "G" designated in part number, for example: P431P_0160 MEL)

P Shaft with Key

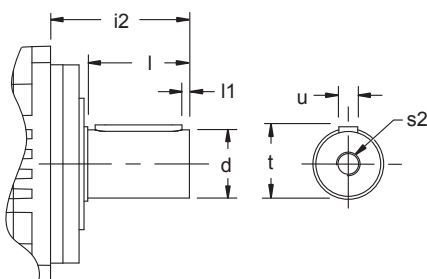

Unit	d k6	l1	l	i2	s2 ⁽¹⁾	t	u ⁽²⁾
	mm	mm	mm	mm		mm	W x H x L
P5	32	3	58	88	M12	35	A10X8X50
P7	40	4	82	112	M16	43	A12X8X70
P8	55	6	82	112	M20	59	A16X10X70
P9	75	7	105	143	M20	79.5	A20X12X90

G Shaft without Key

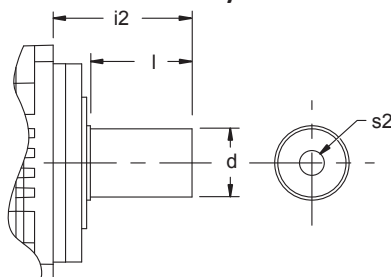

Unit	d k6	l	i2	s2 ⁽¹⁾
	mm	mm	mm	
P5	32	58	88	M12
P7	40	82	112	M16
P8	55	82	112	M20
P9	75	105	143	M20

⁽¹⁾ The center hole in shafts with keys (Option "P") are machined to DIN 332 T2 shape DR.

⁽²⁾ Feather keys are toleranced according to standard DIN 6885.

PK Series: RIGHT ANGLE – Shaft Output

PK Series: RIGHT ANGLE – Shaft Output

PK Series Direction of Rotation

For PK units, the “P” Series planetary output unit can be mounted on either the right (Side 3) or the left (Side 4) of the “K” Series right angle secondary unit. Note CCW input direction of rotation and CW output shaft direction with both mounting configurations.

IMPORTANT: When ordering, Mounting Side 3 or Side 4 **MUST BE SPECIFIED.**

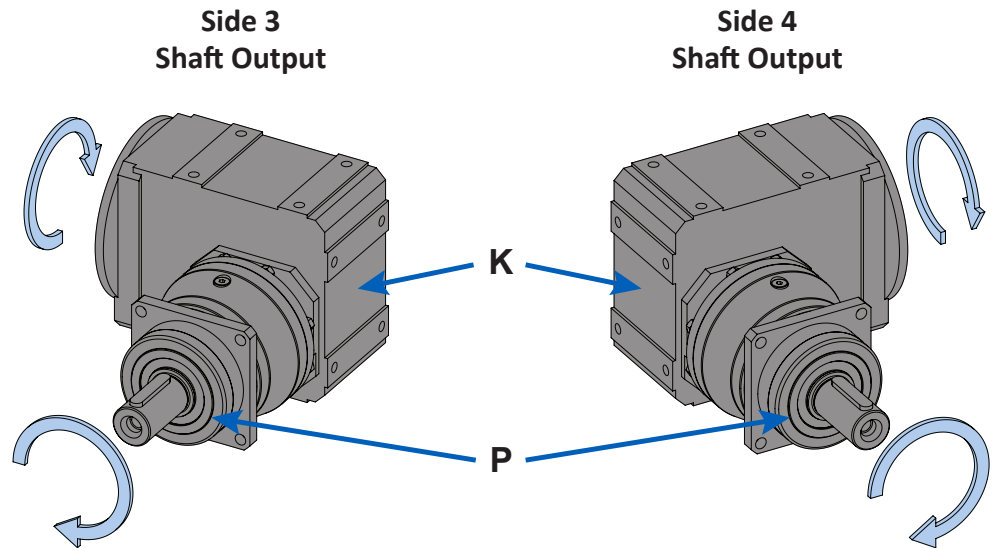

PK Mounting Position Options

When ordering any PK unit, the Mounting Position **MUST BE SPECIFIED** using one of the Mounting Position order codes below.

*Note: the code relates to the orientation side that faces down.
For example, EL1 has side 1 facing down, EL2 has side 2 facing down, etc.*

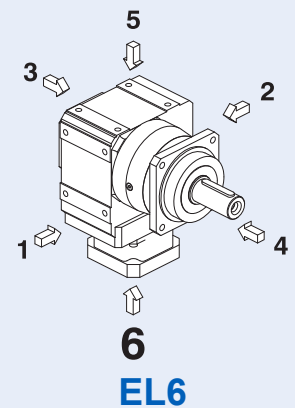
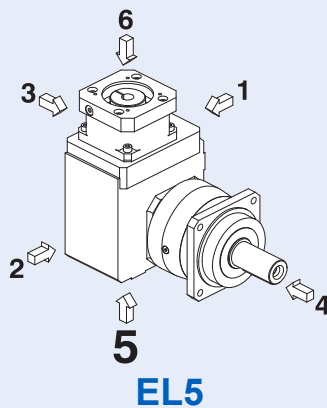
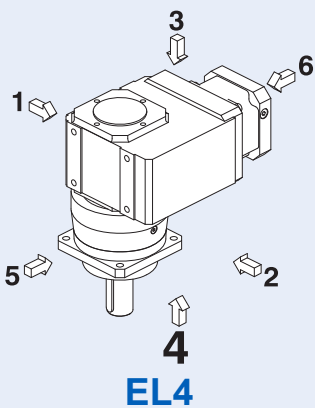
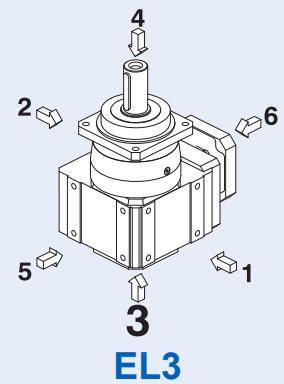
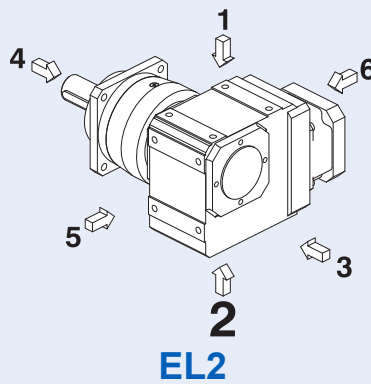
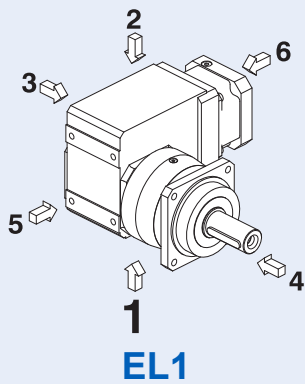

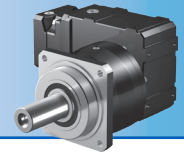

Overview

PK Series Output Bearing Options

S Ball Bearing

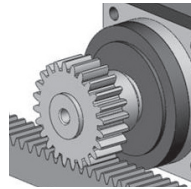

D Double Row Angular Contact Bearing

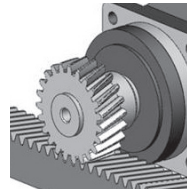

Z Cylindrical Roller Bearing ("Z" cylindrical roller bearing not allowed with reduced backlash option.)

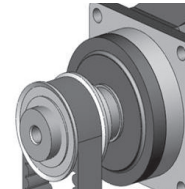

Characteristics:	<ul style="list-style-type: none"> Minimal frictional torque Good radial load capacity Axial load approx. 35% of radial load 	<ul style="list-style-type: none"> Low frictional torque Good radial bearing capacity Axial load approx. 50% of radial load 	<ul style="list-style-type: none"> Very good radial load capacity Axial load approx. 20% of radial load
Applications:	<ul style="list-style-type: none"> Spur geared rack/pinion Couplings Belt with or without light tension 	<ul style="list-style-type: none"> Helical geared rack/pinion Couplings with high axial load Belt with or without light tension 	<ul style="list-style-type: none"> Prestressed belt drive Prestressed spur rack drive Applications with high radial loads and/or high service requirements

PK Series: RIGHT ANGLE – Shaft Output

Permissible Output Shaft Load and Tilting Moments*

Unit	Z ₂ Distance of Shaft Shoulder to Center of Output Bearing mm	F _{2ax100} Permitted Axial Force N	F _{2rad100} Permitted Radial Force ≤100RPM N	F _{2rad,acc} Radial Acceleration Force N	M _{2K100} Permitted Tilting Torque ≤100RPM Nm	M _{2k,acc} Permitted Acceleration Tilting Torque Nm
S Ball Bearing						
P5	19.5	2300	6500	7000	315	340
P7	23	2900	8000	9000	544	576
P8	24.5	4700	13,000	18,000	852	1179
P9	33	6000	18,000	27,000	1539	2309
D Double Row Angular Contact Bearing						
P5	25.5	6000	7000	8000	382	436
P7	29	10,000	9000	10,000	665	700
P8	32	15,500	15,000	18,000	1095	1314
P9	44	25,000	20,000	30,000	1930	2895
Z Cylindrical Roller Bearing						
P5	19.5	1600	8000	8000	388	388
P7	23	2000	10,000	10,000	640	640
P8	24.5	3600	18,000	18,000	1179	1179
P9	33	5000	27,000	35,000	2309	2993

* Refer to illustration and load/life/speed definitions on page 190

During EMERGENCY OFF operation (maximum stops per gearhead = 1000) the permissible values in the table for F_{2A}, F_{2R}, and M_{2K} can be multiplied by a factor of 2. The permissible load values given are valid with the load applied to the center of the output shaft (x₂).

PK Series: RIGHT ANGLE – Shaft Output

PK No Load Running Torque*

Input Ratio T_R

Unit	One Stage								Two Stage										
	3	4	5	7	8	10	12	16	20	25	28	32	35	40	50	56	70	80	100
P5 Nm	0.60	0.45	0.40	0.30	0.20	0.20	0.23	0.23	0.23	0.18	0.18	0.23	0.18	0.18	0.18	0.18	0.18	0.18	0.18
P7 Nm	0.83	0.53	0.43	0.33	0.23	0.23	0.30	0.30	0.30	0.20	0.20	0.30	0.20	0.20	0.20	0.20	0.20	0.20	0.20
P8 Nm	1.05	0.75	0.65	0.45	0.35	0.35	0.48	0.43	0.43	0.33	0.33	0.43	0.23	0.23	0.23	0.23	0.23	0.23	0.23
P9 Nm	–	0.92	0.72	0.52	–	0.42	–	0.55	0.55	0.45	0.45	–	0.35	0.35	0.35	–	0.35	–	0.35

* Torque is measured with the input at 2000 RPM and an ambient temperature of 20° C.

Permissible Motor Tilting Torque

The permissible tilting torque of the motor attached to the gear unit is a result of the static and dynamic load "F" from the motor weight, mass acceleration, and vibration multiplied by the distance from the center of gravity "l_s" of the motor.

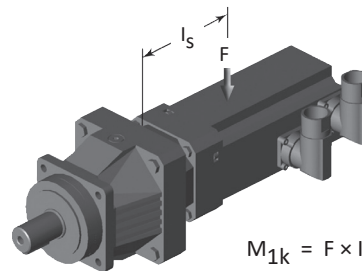

$$M_{1k} = F \times l_s \leq M_{1K}$$

	M1K	ME10	ME20	ME30	ME40	ME50
Nm		25	60	125	250	600

PK Series Load/Life/Speed Calculations

The permissible load and tilting moment values are based on an output speed of 100 RPM. For higher speeds the following applies, where n_2 is the desired speed:

$$F_{2ax} = \frac{F_{2ax100}}{\sqrt[3]{\frac{n_2}{100}}} \quad F_{2rx} = \frac{F_{2rad100}}{\sqrt[3]{\frac{n_2}{100}}} \quad M_{2kx} = \frac{M_{2k100}}{\sqrt[3]{\frac{n_2}{100}}}$$

The application output tilting moment should be determined by the following formula:

$$M_{2k,acc^*} = \frac{2 \cdot F_{2ax100} \cdot y_2 + F_{2rad,acc} \cdot (x_2 + z_2)}{1000} \leq M_{2k,acc}$$

$$M_{2k,eq^*} = \sqrt[3]{\frac{n_{2b1} \cdot t_{b1} \cdot M_{2kb1}^3 + \dots + n_{2bn} \cdot t_{bn} \cdot M_{2kbn}^3}{n_{2b1} \cdot t_{b1} + \dots + n_{2bn} \cdot t_{bn}}} \leq M_{2kN}$$

$$F_{2rad,eq^*} = \sqrt[3]{\frac{n_{2b1} \cdot t_{b1} \cdot F_{2rb1}^3 + \dots + n_{2bn} \cdot t_{bn} \cdot F_{2rnb}^3}{n_{2b1} \cdot t_{b1} + \dots + n_{2bn} \cdot t_{bn}}} \leq F_{2radN}$$

Where:

Z₂	Distance of Shaft Shoulder to Center of Output Bearing	F_{2rad,acc}	Radial Acceleration Force
n₂	Actual Average Output Speed	F_{2rad,acc}*	Radial Acceleration Force at Gear Unit Output
X₂	Distance of the Shaft Shoulder to the Force Application Point	M_{2K100}	Permitted Tilting Torque ≤100RPM
Y₂	Distance of the Shaft Axis to the Axial Force Application Point	M_{2K,acc}	Permitted Acceleration Tilting Torque
F_{2ax}*	Actual Axial Force at Gear Unit Output	M_{2k,acc}*	Permitted Acceleration Tilting Torque at Gear Unit Output
F_{2ax100}	Permitted Axial Force	C_{2K}	Tilting Stiffness
F_{2rad100}	Permitted Radial Force ≤100RPM		

All formulas shown are based on METRIC values
Upper case letters are permissible values. Lower case letters are for existing values.

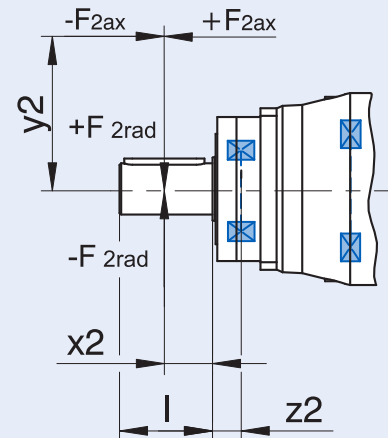

The hours of life (L_h) of the unit can be determined by the following formula:

bearing life for duty cycle ≤ 40%

$$L_h > 10,000 \text{ hours if } M_{2K100}/M_{2A} < 1.25 \text{ and } > 1$$

$$L_h > 20,000 \text{ hours if } M_{2K100}/M_{2A} > 1.25 \text{ and } > 1.5$$

$$L_h > 30,000 \text{ hours if } M_{2K100}/M_{2A} < 1.5$$

bearing life for duty cycle ≥ 40%

$$L_{hA} = L_h \left(\frac{40\%}{\text{Duty Cycle}} \right)$$

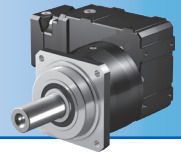

Selection Data

Reducer Ratio (i)		Output Torque					Backlash/Red $\Delta\phi_2$	Part Number* (Gearhead + Input)	Max. Input Speed RPM (n1)			Motor Shaft ³⁾ Max ϕ d_{MW}	Input Inertia J_1	Tors. Stiffness C_2
		Nom. ¹⁾ M_{ZN}	Accel. M_{Zacc}	Accel. Torque for Reduced Backlash M_{ZacHT}	Peak ²⁾ M_{ZNOT}	arcmin			Continuous	Cyclic	mm			
Nom.	Exact	Nm	Nm	Nm	Nm	arcmin		EL 1,2	EL 3,4,5,6	All				

P5K

12.00	12/1	120	200	200	360	5.0/3.0	P531_0030K102_0040 ME10	3300	2800	5000	≤19	1.7	22
							P531_0030K102_0040 ME20				≤24	3.6	
16.00	16/1	210	300	320	480	4.5/2.5	P531_0040K102_0040 ME10	3300	2800	5000	≤19	1.6	26
							P531_0040K102_0040 ME20				≤24	3.5	
20.00	20/1	220	350	385	600	4.0/2.0	P531_0050K102_0040 ME10	3300	2800	5000	≤19	1.5	29
							P531_0050K102_0040 ME20				≤24	3.4	
27.84	7600/273	220	350	385	700	4.0/2.0	P531_0050K102_0056 ME10	3300	2800	5000	≤19	1.3	29
							P531_0050K102_0056 ME20				≤24	3.2	
30.00	30/1	220	350	385	700	4.0/2.0	P531_0050K102_0060 ME10	3300	2800	5000	≤19	1.1	29
							P531_0050K102_0060 ME20				≤24	3.0	
33.22	299/9	220	350	385	700	4.0/2.0	P531_0050K102_0066 ME10	3600	3300	5500	≤19	1.0	29
							P531_0050K102_0066 ME20				≤24	2.9	
41.55	1911/46	220	350	385	700	4.0/2.0	P531_0050K102_0083 ME10	3600	3300	5500	≤19	0.93	29
							P531_0050K102_0083 ME20				≤24	2.8	
46.25	8740/189	220	350	385	700	4.0/2.0	P531_0050K102_0092 ME10	3600	3300	5500	≤19	0.97	29
							P531_0050K102_0092 ME20				≤24	2.9	
57.83	1330/23	220	350	385	700	4.0/2.0	P531_0050K102_0115 ME10	3600	3300	5500	≤19	0.87	29
							P531_0050K102_0115 ME20				≤24	2.8	
70.57	494/7	220	350	385	700	4.0/2.0	P531_0050K102_0140 ME10	4000	3800	6000	≤19	0.82	29
							P531_0050K102_0140 ME20	3700	3700		≤24	2.7	
87.82	10,450/119	220	350	385	700	4.0/2.0	P531_0050K102_0175 ME10	4000	3800	6000	≤19	0.77	29
							P531_0050K102_0175 ME20	3700	3700		≤24	2.7	
116.3	5700/49	220	350	385	700	4.0/2.0	P531_0050K102_0230 ME10	4000	4000	7000	≤19	0.72	29
							P531_0050K102_0230 ME20	3700	3700	6000	≤24	2.6	
140.2	2945/21	220	350	385	700	4.0/2.0	P531_0050K102_0280 ME10	4000	4000	7000	≤19	0.70	29
							P531_0050K102_0280 ME20	3700	3700	6000	≤24	2.6	
175.5	3686/21	220	350	385	700	4.0/2.0	P531_0050K102_0350 ME10	4000	4000	7000	≤19	0.68	29
							P531_0050K102_0350 ME20	3700	3700	6000	≤24	2.6	
234.6	11,495/49	220	350	385	700	4.0/2.0	P531_0050K102_0470 ME10	4000	4000	7000	≤19	0.63	29
280.5	5890/21	220	350	385	700	4.0/2.0	P531_0050K102_0560 ME10	4000	4000	7000	≤19	0.62	29

PK Series: RIGHT ANGLE – Shaft Output

¹⁾ Based on input speed of 1500 RPM. See page 186 for details on torque calculations.

²⁾ Maximum momentary torque for emergency stops or heavy shock load. (Admissible stops per life of gearhead = 1,000 stops maximum.)

* MF = Motor adapter with FlexiAdapt® coupling

PK Series: RIGHT ANGLE – Shaft Output

Reducer Ratio (i)		Output Torque					Backlash/ Red $\Delta\phi_2$	Part Number* (Gearhead + Input)	Max. Input Speed RPM (n1)			Motor Shaft ³⁾ Max ϕ d_{MW}	Input Inertia J_1	Tors. Stiffness C_2
		Nom. ¹⁾ M_{2N}	Accel. M_{2acc}	Accel. Torque for Reduced Backlash M_{2accHT}	Peak ²⁾ M_{2NOT}				Continuous	Cyclic	EL 1,2			
Nom.	Exact	Nm	Nm	Nm	Nm	arcmin						mm	kgcm ²	Nm/arcmin
P7K (continued next page)														
12.00	12/1	300	500	500	900	4.5/2.5	P731_0030K202_0040 ME20	3000	2600	4500	≤32	7.0	39	
							P731_0030K202_0040 ME30				≤38	12		
16.00	16/1	440	677	677	1200	4.5/2.5	P731_0040K202_0040 ME20	3000	2600	4500	≤32	6.7	49	
							P731_0040K202_0040 ME30				≤38	12		
20.00	20/1	440	805	840	1500	4.0/2.0	P731_0050K202_0040 ME20	3000	2600	4500	≤32	6.6	53	
							P731_0050K202_0040 ME30				≤38	12		
25.89	10,535/407	440	805	840	1610	4.0/2.0	P731_0050K202_0052 ME20	3000	2600	4500	≤32	5.7	53	
							P731_0050K202_0052 ME30				≤38	11		
28.00	28/1	440	633	633	841	4.0/2.0	P731_0070K102_0040 ME10	3300	2800	5000	≤19	1.6	51	
							P731_0070K102_0040 ME20				≤24	3.5		
30.00	30/1	440	677	677	900	4.0/2.0	P731_0050K202_0060 ME10	3000	2600	4500	≤19	2.4	53	
			805	840	1610		P731_0050K202_0060 ME20				≤32	5.8		
							P731_0050K202_0060 ME30				≤38	11		
33.42	11,395/341	440	755	755	1003	4.0/2.0	P731_0050K202_0067 ME10	3500	3100	5000	≤19	1.8	53	
			805	840	1610		P731_0050K202_0067 ME20				≤32	5.2		
							P731_0050K202_0067 ME30				≤38	10		
38.98	1520/39	440	741	741	1170	4.0/2.0	P731_0070K102_0056 ME10	3300	2800	5000	≤19	1.3	52	
							P731_0070K102_0056 ME20				≤24	3.2		
40.00	40/1	350	575	575	1150	3.5/1.5	P731_0100K102_0040 ME10	3300	2800	5000	≤19	1.5	50	
							P731_0100K102_0040 ME20				≤24	3.4		
41.99	12,470/297	440	805	840	1260	4.0/2.0	P731_0050K202_0084 ME10	3500	3100	5000	≤19	1.4	53	
					1610		P731_0050K202_0084 ME20				≤32	4.8		
												P731_0050K202_0084 ME30		≤38
42.00	42/1	440	760	760	1260	4.0/2.0	P731_0070K102_0060 ME10	3300	2800	5000	≤19	1.1	52	
							P731_0070K102_0060 ME20				≤24	3.0		
45.95	11,395/248	440	805	840	1379	4.0/2.0	P731_0050K202_0092 ME10	3500	3100	5000	≤19	1.6	53	
					1610		P731_0050K202_0092 ME20				≤32	5.0		
												P731_0050K202_0092 ME30		≤38
46.51	2093/45	440	786	786	1396	4.0/2.0	P731_0070K102_0066 ME10	3600	3300	5500	≤19	1.1	52	
							P731_0070K102_0066 ME20				≤24	3.0		
55.68	15,200/273	350	575	575	1150	3.5/1.5	P731_0100K102_0056 ME10	3300	2800	5000	≤19	1.3	50	
							P731_0100K102_0056 ME20				≤24	3.2		

¹⁾ Based on input speed of 1500 RPM. See page 186 for details on torque calculations.

²⁾ Maximum momentary torque for emergency stops or heavy shock load. (Admissible stops per life of gearhead = 1,000 stops maximum.)

* MF = Motor adapter with FlexiAdapt® coupling

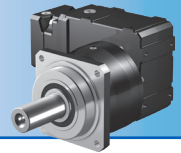

Selection Data

Reducer Ratio (i)		Output Torque					Backlash/Red $\Delta\phi_2$	Part Number* (Gearhead + Input)	Max. Input Speed RPM (n1)			Motor Shaft ³⁾ Max ϕ d _{MW}	Input Inertia J ₁	Tors. Stiffness C ₂
		Nom. ¹⁾ M _{ZN}	Accel. M _{Zac}	Accel. Torque for Reduced Backlash M _{ZacHT}	Peak ²⁾ M _{2NOT}	arcmin			Continuous		Cyclic			
Nom.	Exact	Nm	Nm	Nm	Nm	arcmin		EL 1,2	EL 3,4,5,6	All	mm	kgcm ²	Nm/arcmin	

P7K (continued next page)

57.73	6235/108	440	805	840	1610	4.0/2.0	P731_0050K202_0115 ME10	3500	3100	5000	≤19	1.3	53
							P731_0050K202_0115 ME20				≤32	4.7	
							P731_0050K202_0115 ME30				≤38	10	
58.16	13,377/230	440	805	840	1561	4.0/2.0	P731_0070K102_0083 ME10	3600	3300	5500	≤19	0.94	52
							P731_0070K102_0083 ME20				≤24	2.8	
60.00	60/1	350	575	575	1150	3.5/1.5	P731_0100K102_0060 ME10	3300	2800	5000	≤19	1.1	50
							P731_0100K102_0060 ME20				≤24	3.0	
64.74	1748/27	440	805	840	1561	4.0/2.0	P731_0070K102_0092 ME10	3600	3300	5500	≤19	0.97	52
							P731_0070K102_0092 ME20				≤24	2.9	
66.44	598/9	350	575	575	1150	3.5/1.5	P731_0100K102_0066 ME10	3600	3300	5500	≤19	1.0	50
							P731_0100K102_0066 ME20				≤24	2.9	
69.26	14,405/208	440	805	840	1610	4.0/2.0	P731_0050K202_0140 ME10	3900	3500	5500	≤19	1.1	53
							P731_0050K202_0140 ME20	3700			≤32	4.5	
							P731_0050K202_0140 ME30	3500			5000	≤38	
70.98	3549/50	440	805	840	1561	4.0/2.0	P731_0070K102_0100 ME10	4000	3700	6000	≤19	0.86	52
							P731_0070K102_0100 ME20	3700			≤24	2.8	
80.96	1862/23	440	805	840	1561	4.0/2.0	P731_0070K102_0115 ME10	3600	3300	5500	≤19	0.88	52
							P731_0070K102_0115 ME20				≤24	2.8	
83.09	1911/23	350	575	575	1150	3.5/1.5	P731_0100K102_0083 ME10	3600	3300	5500	≤19	0.93	50
							P731_0100K102_0083 ME20				≤24	2.8	
87.35	2795/32	440	805	840	1610	4.0/2.0	P731_0050K202_0175 ME10	3900	3500	5500	≤19	1.0	53
							P731_0050K202_0175 ME20	3700			≤32	4.4	
							P731_0050K202_0175 ME30	3500			5000	≤38	
88.33	3003/34	440	805	840	1561	4.0/2.0	P731_0070K102_0125 ME10	4000	3700	6000	≤19	0.79	52
							P731_0070K102_0125 ME20	3700			≤24	2.7	
92.49	17,480/189	350	575	575	1150	3.5/1.5	P731_0100K102_0092 ME10	3600	3300	5500	≤19	0.96	50
							P731_0100K102_0092 ME20				≤24	2.9	
98.80	494/5	440	805	840	1561	4.0/2.0	P731_0070K102_0140 ME10	4000	3700	6000	≤19	0.82	52
							P731_0070K102_0140 ME20	3700			≤24	2.7	
115.7	2660/23	350	575	575	1150	3.5/1.5	P731_0100K102_0115 ME10	3600	3300	5500	≤19	0.87	50
							P731_0100K102_0115 ME20				≤24	2.8	
115.9	14,835/128	440	805	840	1610	4.0/2.0	P731_0050K202_0230 ME10	4000	3700	6000	≤19	0.87	53
							P731_0050K202_0230 ME20	3700			≤32	4.3	
							P731_0050K202_0230 ME30	3500			5000	≤38	

PK Series: RIGHT ANGLE – Shaft Output

¹⁾ Based on input speed of 1500 RPM. See page 186 for details on torque calculations.

²⁾ Maximum momentary torque for emergency stops or heavy shock load. (Admissible stops per life of gearhead = 1,000 stops maximum.)

* MF = Motor adapter with FlexiAdapt® coupling

Reducer Ratio (i)		Output Torque					Backlash/ Red $\Delta\phi_2$	Part Number* (Gearhead + Input)	Max. Input Speed RPM (n1)			Motor Shaft ³⁾ Max ϕ d _{MW}	Input Inertia J ₁	Tors. Stiffness C ₂
		Nom. ¹⁾ M _{2N}	Accel. M _{2acc}	Accel. Torque for Reduced Backlash M _{2accHT}	Peak ²⁾ M _{2NOT}	arcmin			Continuous	Cyclic	All			
Nom.	Exact	Nm	Nm	Nm	Nm	arcmin		EL 1,2	EL 3,4,5,6	All	mm	kgcm ²	Nm/ arcmin	
P7K (continued from previous page)														
117.0	117/1	440	805	840	1561	4.0/2.0	P731_0070K102_0165 ME10	4000	4000	7000	≤19	0.73	52	
							P731_0070K102_0165 ME20	3700	3700	6000	≤24	2.6		
122.9	2090/17	440	805	840	1561	4.0/2.0	P731_0070K102_0175 ME10	4000	3800	6000	≤19	0.77	52	
							P731_0070K102_0175 ME20	3700	3700		≤24	2.7		
139.8	559/4	440	805	840	1610	4.0/2.0	P731_0050K202_0280 ME10	4000	3900	6500	≤19	0.81	53	
							P731_0050K202_0280 ME20	3700	3700	6000	≤24	2.7		
141.1	2821/20	440	805	840	1561	4.0/2.0	P731_0070K102_0200 ME10	4000	4000	7000	≤19	0.71	52	
							P731_0070K102_0200 ME20	3700	3700	6000	≤24	2.6		
162.9	1140/7	440	805	840	1561	4.0/2.0	P731_0070K102_0230 ME10	4000	4000	7000	≤19	0.72	52	
							P731_0070K102_0230 ME20	3700	3700	6000	≤24	2.6		
172.8	9675/56	440	805	840	1610	4.0/2.0	P731_0050K202_0350 ME10	4000	3900	6500	≤19	0.76	53	
							P731_0050K202_0350 ME20	3700	3700	6000	≤24	2.7		
176.5	8827/50	440	783	783	1386	4.0/2.0	P731_0070K102_0250 ME10	4000	4000	7000	≤19	0.68	52	
							P731_0070K102_0250 ME20	3700	3700	6000	≤24	2.6		
196.3	589/3	440	805	840	1561	4.0/2.0	P731_0070K102_0280 ME10	4000	4000	7000	≤19	0.70	52	
							P731_0070K102_0280 ME20	3700	3700	6000	≤24	2.6		
231.1	1849/8	440	805	840	1610	4.0/2.0	P731_0050K202_0460 ME10	4000	3900	6500	≤19	0.71	53	
							P731_0050K202_0460 ME20	3700	3700	6000	≤24	2.6		
232.7	11,400/49	350	575	575	1150	3.5/1.5	P731_0100K102_0230 ME10	4000	4000	7000	≤19	0.72	50	
							P731_0100K102_0230 ME20	3700	3700	6000	≤24	2.6		
235.9	4719/20	440	595	595	1053	4.0/2.0	P731_0070K102_0340 ME10	4000	4000	7000	≤19	0.63	52	
							P731_0070K102_0350 ME10	4000	4000	7000	≤19	0.68		
245.7	3686/15	440	805	840	1561	4.0/2.0	P731_0070K102_0350 ME10	4000	4000	7000	≤19	0.68	52	
							P731_0070K102_0350 ME20	3700	3700	6000	≤24	2.6		
277.7	6665/24	440	805	840	1392	4.0/2.0	P731_0050K202_0560 ME10	4000	3900	6500	≤19	0.66	53	
							P731_0100K102_0280 ME10	4000	4000	7000	≤19	0.70		
280.5	5890/21	350	575	575	1150	3.5/1.5	P731_0100K102_0280 ME10	4000	4000	7000	≤19	0.70	50	
							P731_0100K102_0280 ME20	3700	3700	6000	≤24	2.6		
282.1	2821/10	417	501	501	887	4.0/2.0	P731_0070K102_0400 ME10	4000	4000	7000	≤19	0.62	52	
328.4	2299/7	440	805	828	1466	4.0/2.0	P731_0070K102_0470 ME10	4000	4000	7000	≤19	0.63	52	
351.1	7372/21	350	575	575	1150	3.5/1.5	P731_0100K102_0350 ME10	4000	4000	7000	≤19	0.68	50	
							P731_0100K102_0350 ME20	3700	3700	6000	≤24	2.6		
352.2	35,217/100	339	407	407	721	4.0/2.0	P731_0070K102_0500 ME10	4000	4000	7000	≤19	0.62	52	
392.7	1178/3	440	697	697	1235	4.0/2.0	P731_0070K102_0560 ME10	4000	4000	7000	≤19	0.62	52	
469.2	22,990/49	350	575	575	1150	3.5/1.5	P731_0100K102_0470 ME10	4000	4000	7000	≤19	0.63	50	
490.2	2451/5	440	566	566	1003	4.0/2.0	P731_0070K102_0700 ME10	4000	4000	7000	≤19	0.62	52	
561.0	11,780/21	350	575	575	1150	3.5/1.5	P731_0100K102_0560 ME10	4000	4000	7000	≤19	0.62	50	

¹⁾ Based on input speed of 1500 RPM. See page 186 for details on torque calculations.

²⁾ Maximum momentary torque for emergency stops or heavy shock load. (Admissible stops per life of gearhead = 1,000 stops maximum.)

* MF = Motor adapter with FlexiAdapt® coupling

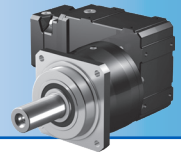

Selection Data

Reducer Ratio (i)		Output Torque					Backlash/Red $\Delta\phi_2$	Part Number* (Gearhead + Input)	Max. Input Speed RPM (n1)			Motor Shaft ³⁾ Max ϕ d _{MW}	Input Inertia J ₁	Tors. Stiffness C ₂
		Nom. ¹⁾ M _{ZN}	Accel. M _{ZACC}	Accel. Torque for Reduced Backlash M _{ZaccHT}	Peak ²⁾ M _{ZNOT}	arcmin			Continuous	Cyclic	EL 1,2			
Nom.	Exact	Nm	Nm	Nm	Nm	arcmin						mm	kgcm ²	

P8K (continued next page)

12.00	12/1	593	677	677	900	4.5/2.5	P831_0030K302_0040 ME20	2700	2300	4000	≤32	12	81	
			889	889	2165		P831_0030K302_0040 ME30				≤38	17	83	
16.00	16/1	790	903	903	1200	4.0/2.0	P831_0040K302_0040 ME20	2700	2300	4000	≤32	10	108	
			1186	1186	2887		P831_0040K302_0040 ME30				≤38	16	109	
20.00	20/1	988	1129	1129	1500	4.0/2.0	P831_0050K302_0040 ME20	2700	2300	4000	≤32	9.7	126	
			1482	1482	3230		P831_0050K302_0040 ME30				≤38	15	127	
26.88	215/8	1090	1518	1518	2016	4.0/2.0	P831_0050K302_0054 ME20	2700	2300	4000	≤32	7.6	127	
							P831_0050K302_0054 ME30				≤38	13		
28.00	28/1	790	1185	1185	2100	3.5/1.5	P831_0070K202_0040 ME20	3000	2600	4500	≤32	6.8	128	
							P831_0070K202_0040 ME30				≤38	12		
30.00	30/1	1100	1694	1694	2250	4.0/2.0	P831_0050K302_0060 ME20	2700	2300	4000	≤32	7.8	127	
			1697	1697	3230		P831_0050K302_0060 ME30				≤38	13	128	
30.55	336/11	690	690	690	916	3.5/1.5	P831_0070K202_0044 ME10	3000	2600	4500	≤19	3.0	125	
			813	1220	1220		2291				P831_0070K202_0044 ME20	≤32	6.4	128
											P831_0070K202_0044 ME30	≤38	12	
36.24	14,749/407	861	1291	1291	2718	3.5/1.5	P831_0070K202_0052 ME20	3000	2600	4500	≤32	5.9	128	
							P831_0070K202_0052 ME30				≤38	11		
36.96	2365/64	1100	1819	1819	2772	4.0/2.0	P831_0050K302_0074 ME20	2700	2300	4000	≤32	6.9	127	
							P831_0050K302_0074 ME30				≤38	12	128	
40.00	40/1	850	1380	1380	2760	3.5/1.5	P831_0100K202_0040 ME20	3000	2600	4500	≤32	6.6	131	
							P831_0100K202_0040 ME30				≤38	12		
42.00	42/1	904	948	948	1260	3.5/1.5	P831_0070K202_0060 ME10	3000	2600	4500	≤19	2.5	127	
			1356	1356	2887		P831_0070K202_0060 ME20				≤32	5.9	128	
							P831_0070K202_0060 ME30				≤38	11		
46.34	5375/116	1100	1840	1867	3230	4.0/2.0	P831_0050K302_0093 ME20	3200	2800	4500	≤32	6.1	128	
							P831_0050K302_0093 ME30				≤38	11		
46.78	15,953/341	937	1057	1057	1404	3.5/1.5	P831_0070K202_0067 ME10	3500	3100	5000	≤19	1.8	127	
			1406	1406	2887		P831_0070K202_0067 ME20				≤32	5.2	128	
							P831_0070K202_0067 ME30				≤38	11		

PK Series: RIGHT ANGLE – Shaft Output

¹⁾ Based on input speed of 1500 RPM. See page 186 for details on torque calculations.

²⁾ Maximum momentary torque for emergency stops or heavy shock load. (Admissible stops per life of gearhead = 1,000 stops maximum.)

* MF = Motor adapter with FlexiAdapt® coupling

PK Series: RIGHT ANGLE – Shaft Output

Reducer Ratio (i)		Output Torque				Backlash/Red $\Delta\phi_2$	Part Number* (Gearhead + Input)	Max. Input Speed RPM (n1)			Motor Shaft ³⁾ Max ϕ d _{MW}	Input Inertia J ₁	Tors. Stiffness C ₂
		Nom. ¹⁾ M _{2N}	Accel. M _{2acc}	Accel. Torque for Reduced Backlash M _{2accHT}	Peak ²⁾ M _{2NOT}			Continuous	Cyclic	EL 1,2			
Nom.	Exact	Nm	Nm	Nm	Nm	arcmin					mm	kgcm ²	Nm/arcmin
P8K (continued next page)													
49.83	14,749/296	957	1436	1436	2887	3.5/1.5	P831_0070K202_0071 ME20	3000	2600	4500	≤32	5.5	128
							P831_0070K202_0071 ME30				≤38	11	
51.77	21,070/407	850	1380	1380	2760	3.5/1.5	P831_0100K202_0052 ME20	3000	2600	4500	≤32	5.8	131
							P831_0100K202_0052 ME30				≤38	11	
58.05	1161/20	1100	1311	1311	1742	4.0/2.0	P831_0050K302_0115 ME10	3200	2800	4500	≤19	2.1	127
			1840	1867	3230		P831_0050K302_0115 ME20				≤32	5.5	
							P831_0050K302_0115 ME30				≤38	11	
58.78	17,458/297	1000	1328	1328	1763	3.5/1.5	P831_0070K202_0084 ME10	3500	3100	5000	≤19	1.5	128
			1494	1494	2887		P831_0070K202_0084 ME20				≤32	4.9	
							P831_0070K202_0084 ME30				≤38	10	
60.00	60/1	850	1355	1355	1800	3.5/1.5	P831_0100K202_0060 ME10	3000	2600	4500	≤19	2.4	131
			1380	1380	2760		P831_0100K202_0060 ME20				≤32	5.8	
							P831_0100K202_0060 ME30				≤38	11	
64.33	15,953/248	1000	1453	1453	1931	3.5/1.5	P831_0070K202_0092 ME10	3500	3100	5000	≤19	1.6	128
			1494	1494	2887		P831_0070K202_0092 ME20				≤32	5.0	
							P831_0070K202_0092 ME30				≤38	10	
66.83	22,790/341	850	1380	1380	2006	3.5/1.5	P831_0100K202_0067 ME10	3500	3100	5000	≤19	1.8	131
					2760		P831_0100K202_0067 ME20				≤32	5.2	
												P831_0100K202_0067 ME30	
69.68	7525/108	1100	1574	1574	2091	4.0/2.0	P831_0050K302_0140 ME10	3500	3100	5000	≤19	1.7	127
			1840	1867	3230		P831_0050K302_0140 ME20				≤32	5.1	
							P831_0050K302_0140 ME30				≤38	10	
70.51	20,167/286	1000	1494	1494	2116	3.5/1.5	P831_0070K202_0100 ME10	3900	3500	5500	≤19	1.3	128
					2887		P831_0070K202_0100 ME20	3700			≤32	4.7	
							P831_0070K202_0100 ME30	3500			≤38	10	
80.82	8729/108	1000	1494	1494	2425	3.5/1.5	P831_0070K202_0115 ME10	3500	3100	5000	≤19	1.3	128
					2887		P831_0070K202_0115 ME20				≤32	4.7	
							P831_0070K202_0115 ME30				≤38	10	

¹⁾ Based on input speed of 1500 RPM. See page 186 for details on torque calculations.

²⁾ Maximum momentary torque for emergency stops or heavy shock load. (Admissible stops per life of gearhead = 1,000 stops maximum.)

* MF = Motor adapter with FlexiAdapt® coupling

Selection Data

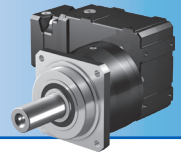

Reducer Ratio (i)		Output Torque				Backlash/Red $\Delta\phi_2$	Part Number* (Gearhead + Input)	Max. Input Speed RPM (n1)			Motor Shaft ³⁾ Max ϕ d_{MW}	Input Inertia J_1	Tors. Stiffness C_2
		Nom. ¹⁾ M_{ZN}	Accel. M_{Zacc}	Accel. Torque for Reduced Backlash M_{ZaccHT}	Peak ²⁾ M_{ZNOT}			Continuous	Cyclic	EL 1,2			
Nom.	Exact	Nm	Nm	Nm	Nm	arcmin							Nm/arcmin

P8K (continued next page)

83.97	24,940/297	850	1380	1380	2520	3.5/1.5	P831_0100K202_0084 ME10	3500	3100	5000	≤19	1.4	131	
					2760		P831_0100K202_0084 ME20				≤32	4.8		
							P831_0100K202_0084 ME30				≤38	10		
86.47	7955/92	1100	1840	1867	2594	4.0/2.0	P831_0050K302_0175 ME10	3500	3100	5000	≤19	1.4	128	
					3230		P831_0050K302_0175 ME20				≤32	4.8		
							P831_0050K302_0175 ME30				≤38	10		
88.94	3913/44	1000	1494	1494	2669	3.5/1.5	P831_0070K202_0125 ME10	3900	3500	5500	≤19	1.1	128	
					2887		P831_0070K202_0125 ME20	3700		≤32	4.5			
							P831_0070K202_0125 ME30	3500		5000	≤38	9.8		
91.90	11,395/124	850	1380	1380	2758	3.5/1.5	P831_0100K202_0092 ME10	3500	3100	5000	≤19	1.6	131	
					2760		P831_0100K202_0092 ME20				≤32	5.0		
							P831_0100K202_0092 ME30				≤38	10		
96.96	20,167/208	1000	1494	1494	2887	3.5/1.5	P831_0070K202_0140 ME10	3900	3500	5500	≤19	1.2	128	
								P831_0070K202_0140 ME20		3700	≤32	4.6		
								P831_0070K202_0140 ME30		3500	5000	≤38		9.9
115.5	6235/54	850	1380	1380	2760	3.5/1.5	P831_0100K202_0115 ME10	3500	3100	5000	≤19	1.3	131	
											P831_0100K202_0115 ME20	≤32		4.7
											P831_0100K202_0115 ME30	≤38		10
116.5	2795/24	1100	1840	1867	3230	4.0/2.0	P831_0050K302_0230 ME10	3800	3500	6000	≤19	1.1	128	
								P831_0050K302_0230 ME20		3700	≤32	4.5		
								P831_0050K302_0230 ME30		3500	5000	≤38		9.9
118.0	20,769/176	1000	1494	1494	2887	3.5/1.5	P831_0070K202_0170 ME10	4000	3900	6500	≤19	0.91	128	
								P831_0070K202_0170 ME20	3700	3700	6000	≤32		4.3
								P831_0070K202_0170 ME30	3500	3500	5000	≤38		9.6
122.3	3913/32	1000	1494	1494	2887	3.5/1.5	P831_0070K202_0175 ME10	3900	3500	5500	≤19	1.0	128	
								P831_0070K202_0175 ME20		3700	≤32	4.4		
								P831_0070K202_0175 ME30		3500	5000	≤38		9.7

PK Series: RIGHT ANGLE – Shaft Output

¹⁾ Based on input speed of 1500 RPM. See page 186 for details on torque calculations.

²⁾ Maximum momentary torque for emergency stops or heavy shock load. (Admissible stops per life of gearhead = 1,000 stops maximum.)

* MF = Motor adapter with FlexiAdapt® coupling

PK Series: RIGHT ANGLE – Shaft Output

Reducer Ratio (i)		Output Torque					Backlash/Red $\Delta\phi_2$	Part Number* (Gearhead + Input)	Max. Input Speed RPM (n1)			Motor Shaft ³⁾ Max ϕ d_{MW}	Input Inertia J_1	Tors. Stiffness C_2
		Nom. ¹⁾ M_{2N}	Accel. M_{2acc}	Accel. Torque for Reduced Backlash M_{2accHT}	Peak ²⁾ M_{2NOT}				Continuous	Cyclic	EL 1,2			
Nom.	Exact	Nm	Nm	Nm	Nm	arcmin						mm	kgcm ²	Nm/arcmin

P8K (continued next page)

138.5	14,405/104	850	1380	1380	2760	3.5/1.5	P831_0100K202_0140 ME10	3900	3500	5500	≤19	1.1	131
							P831_0100K202_0140 ME20	3700			≤32	4.6	
							P831_0100K202_0140 ME30	3500			5000	≤38	
139.4	17,845/128	1100	1840	1867	3230	4.0/2.0	P831_0050K302_0280 ME10	3800	3500	6000	≤19	1.0	128
							P831_0050K302_0280 ME20	3700			≤32	4.4	
							P831_0050K302_0280 ME30	3500			5000	≤38	
142.3	7826/55	1000	1494	1494	2887	3.5/1.5	P831_0070K202_0200 ME10	4000	3900	6500	≤19	0.84	128
							P831_0070K202_0200 ME20	3700	3700	6000	≤24	2.7	
162.3	20,769/128	1000	1494	1494	2887	3.5/1.5	P831_0070K202_0230 ME10	4000	3900	6500	≤19	0.88	128
							P831_0070K202_0230 ME20	3700	3700	6000	≤32	4.3	
							P831_0070K202_0230 ME30	3500	3500	5000	≤38	9.6	
173.7	4515/26	1100	1840	1867	3230	4.0/2.0	P831_0050K302_0350 ME10	3800	3500	6000	≤19	0.90	128
							P831_0050K302_0350 ME20	3700			≤24	2.8	
174.7	2795/16	850	1380	1380	2760	3.5/1.5	P831_0100K202_0175 ME10	3900	3500	5500	≤19	1.0	131
							P831_0100K202_0175 ME20	3700			≤32	4.4	
							P831_0100K202_0175 ME30	3500			5000	≤38	
175.9	1935/11	1000	1494	1494	2887	3.5/1.5	P831_0070K202_0250 ME10	4000	3900	6500	≤19	0.77	128
							P831_0070K202_0250 ME20	3700	3700	6000	≤24	2.7	
195.7	3913/20	1000	1494	1494	2887	3.5/1.5	P831_0070K202_0280 ME10	4000	3900	6500	≤19	0.81	128
							P831_0070K202_0280 ME20	3700	3700	6000	≤24	2.7	
231.1	1849/8	1100	1840	1867	3230	4.0/2.0	P831_0050K302_0460 ME10	3800	3500	6000	≤19	0.79	128
							P831_0050K302_0460 ME20	3700			≤24	2.7	
231.8	14,835/64	850	1380	1380	2760	3.5/1.5	P831_0100K202_0230 ME10	4000	3900	6500	≤19	0.87	131
							P831_0100K202_0230 ME20	3700	3700	6000	≤32	4.3	
							P831_0100K202_0230 ME30	3500	3500	5000	≤38	9.6	
235.3	12,943/55	1000	1255	1255	2223	3.5/1.5	P831_0070K202_0340 ME10	4000	3900	6500	≤19	0.72	128
							P831_0070K202_0340 ME20	3700	3700	6000	≤24	2.6	

¹⁾ Based on input speed of 1500 RPM. See page 186 for details on torque calculations.

²⁾ Maximum momentary torque for emergency stops or heavy shock load. (Admissible stops per life of gearhead = 1,000 stops maximum.)

* MF = Motor adapter with FlexiAdapt® coupling

Selection Data

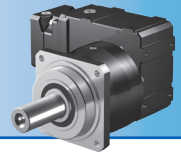

Reducer Ratio (i)		Output Torque					Backlash/Red $\Delta\phi_2$	Part Number* (Gearhead + Input)	Max. Input Speed RPM (n1)			Motor Shaft ³⁾ Max ϕ d _{MW}	Input Inertia J ₁	Tors. Stiffness C ₂
		Nom. ¹⁾ M _{ZN}	Accel. M _{Zacc}	Accel. Torque for Reduced Backlash M _{ZaccHT}	Peak ²⁾ M _{ZNOT}	arcmin			Continuous	Cyclic	EL 1,2			
Nom.	Exact	Nm	Nm	Nm	Nm	arcmin						mm	kgcm ²	Nm/arcmin

P8K (continued from previous page)

241.9	1935/8	1000	1494	1494	2887	3.5	P831_0070K202_0350 ME10	4000	3900	6500	≤19	0.76	128
							P831_0070K202_0350 ME20	3700	3700	6000	≤24	2.7	
278.5	12,255/44	1100	1541	1541	2729	4.0	P831_0050K302_0560 ME10	3800	3500	6000	≤19	0.75	128
							P831_0050K302_0560 ME20	3700			≤24	2.6	
279.5	559/2	850	1380	1380	2760	3.5	P831_0100K202_0280 ME10	4000	3900	6500	≤19	0.81	131
							P831_0100K202_0280 ME20	3700	3700	6000	≤24	2.7	
282.8	9331/33	784	941	941	1418	3.5	P831_0070K202_0400 ME10	4000	3900	6500	≤19	0.66	128
323.6	12,943/40	1000	1494	1494	2887	3.5	P831_0070K202_0460 ME10	4000	3900	6500	≤19	0.71	128
							P831_0070K202_0460 ME20	3700	3700	6000	≤24	2.6	
345.5	9675/28	850	1380	1380	2760	3.5	P831_0100K202_0350 ME10	4000	3900	6500	≤19	0.76	131
							P831_0100K202_0350 ME20	3700	3700	6000	≤24	2.7	
353.4	46,655/132	654	784	784	1329	3.5	P831_0070K202_0500 ME10	4000	3900	6500	≤19	0.64	128
388.8	9331/24	1000	1294	1294	1949	3.5	P831_0070K202_0560 ME10	4000	3900	6500	≤19	0.66	128
462.3	1849/4	850	1380	1380	2760	3.5	P831_0100K202_0460 ME10	4000	3900	6500	≤19	0.71	131
							P831_0100K202_0460 ME20	3700	3700	6000	≤24	2.6	132
486.0	46,655/96	899	1078	1078	1828	3.5	P831_0070K202_0690 ME10	4000	3900	6500	≤19	0.64	128
555.4	6665/12	850	1380	1380	2760	3.5	P831_0100K202_0560 ME10	4000	3900	6500	≤19	0.66	131

PK Series: RIGHT ANGLE – Shaft Output

¹⁾ Based on input speed of 1500 RPM. See page 186 for details on torque calculations.

²⁾ Maximum momentary torque for emergency stops or heavy shock load. (Admissible stops per life of gearhead = 1,000 stops maximum.)

* MF = Motor adapter with FlexiAdapt® coupling

PK Series: RIGHT ANGLE – Shaft Output

Reducer Ratio (i)		Output Torque					Back- lash/ Red $\Delta\phi_2$	Part Number* (Gearhead + Input)	Max. Input Speed RPM (n1)			Motor Shaft ³⁾ Max ϕ d_{MW}	Input Inertia J_1	Tors. Stiffness C_2
		Nom. ¹⁾ M_{2N}	Accel. M_{2acc}	Accel. Torque for Reduced Backlash M_{2accHT}	Peak ²⁾ M_{2NOT}	Continuous			Cyclic	All				
Nom.	Exact	Nm	Nm	Nm	Nm		arcmin	EL 1,2			EL 3,4,5,6	All	mm	kgcm ²
P9K (continued next page)														
28.00	28/1	2076	3105	-	5600	3.5	P931_0070K402_0040 ME30	2600	2200	3800	≤38	20	303	
							P931_0070K402_0040 ME40				≤48	42		
30.55	336/11	2100	3105	-	6109	3.5	P931_0070K402_0044 ME30	2600	2200	3800	≤38	19	304	
							P931_0070K402_0044 ME40				≤48	41	303	
37.95	12,943/341	2100	3105	-	6210	3.5	P931_0070K402_0054 ME30	2600	2200	3800	≤38	16	304	
							P931_0070K402_0054 ME40				≤48	38		
42.00	42/1	2100	3105	-	6210	3.5	P931_0070K402_0060 ME30	2600	2200	3800	≤38	17	304	
							P931_0070K402_0060 ME40				≤48	39		
47.03	1505/32	2100	2656	-	3529	3.5	P931_0070K402_0067 ME20	3000	2600	4500	≤32	8.6	303	
			3105		6210		P931_0070K402_0067 ME30				≤38	14	304	
					P931_0070K402_0067 ME40		≤48				36			
52.19	12,943/248	2100	3105	-	6210	3.5	P931_0070K402_0075 ME30	2600	2200	3800	≤38	15	305	
							P931_0070K402_0075 ME40				≤48	37		
58.64	645/11	2100	3105	-	4399	3.5	P931_0070K402_0084 ME20	3000	2600	4500	≤32	7.2	304	
					6210		P931_0070K402_0084 ME30				≤38	13	305	
							P931_0070K402_0084 ME40				≤48	35		
64.67	16,555/256	2100	3105	-	4852	3.5	P931_0070K402_0092 ME20	3000	2600	4500	≤32	7.8	304	
					6210		P931_0070K402_0092 ME30				≤38	13	305	
							P931_0070K402_0092 ME40				≤48	35		
70.69	9331/132	2100	3105	-	5302	3.5	P931_0070K402_0100 ME20	3400	3000	5000	≤32	6.4	304	
					6210		P931_0070K402_0100 ME30	3400	3000	5000	≤38	12	305	
							P931_0070K402_0100 ME40	3000		4500	≤48	34		
80.63	645/8	2100	3105	-	6049	3.5	P931_0070K402_0115 ME20	3000	2600	4500	≤32	6.7	305	
					6210		P931_0070K402_0115 ME30				≤38	12		
							P931_0070K402_0115 ME40				≤48	34		
88.61	2924/33	2100	3105	-	6210	3.5	P931_0070K402_0125 ME20	3400	3000	5000	≤32	5.7	305	
							P931_0070K402_0125 ME30			≤38	11			
							P931_0070K402_0125 ME40	3000		4500	≤48	33		

¹⁾ Based on input speed of 1500 RPM. See page 186 for details on torque calculations.

²⁾ Maximum momentary torque for emergency stops or heavy shock load. (Admissible stops per life of gearhead = 1,000 stops maximum.)

* MF = Motor adapter with FlexiAdapt® coupling

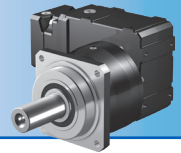

Selection Data

Reducer Ratio (i)		Output Torque					Backlash/Red $\Delta\phi_2$	Part Number* (Gearhead + Input)	Max. Input Speed RPM (n1)			Motor Shaft ³⁾ Max ϕ d _{MW}	Input Inertia J ₁	Tors. Stiffness C ₂
		Nom. ¹⁾ M _{ZN}	Accel. M _{Zacc}	Accel. Torque for Reduced Backlash M _{ZaccHT}	Peak ²⁾ M _{ZNOT}	arcmin			Continuous		Cyclic			
Nom.	Exact	Nm	Nm	Nm	Nm	arcmin		EL 1,2	EL 3,4,5,6	All	mm	kgcm ²	Nm/arcmin	

P9K (continued from previous page)

97.20	9331/96	2100	3105	-	6210	3.5	P931_0070K402_0140 ME20	3400	3000	5000	≤32	6.1	305
							P931_0070K402_0140 ME30				≤38	12	
							P931_0070K402_0140 ME40	3000	4500	≤48	33		
118.6	3913/33	2100	3105	-	6210	3.5	P931_0070K402_0170 ME20	3600	3300	5500	≤32	5.1	305
							P931_0070K402_0170 ME30				3500	5000	
							P931_0070K402_0170 ME40	3000	3000	4500	≤48	32	
121.8	731/6	2100	3105	-	6210	3.5	P931_0070K402_0175 ME20	3400	3000	5000	≤32	5.5	305
							P931_0070K402_0175 ME30				3000	4500	
							P931_0070K402_0175 ME40	3000	4500	≤48	33		
141.4	9331/66	2100	3105	-	6210	3.5	P931_0070K402_0200 ME20	3600	3300	5500	≤32	4.8	305
							P931_0070K402_0200 ME30				3500	5000	
163.0	3913/24	2100	3105	-	6210	3.5	P931_0070K402_0230 ME20	3600	3300	5500	≤32	4.9	305
							P931_0070K402_0230 ME30				3500	5000	
							P931_0070K402_0230 ME40	3000	3000	4500	≤48	32	
177.0	29,197/165	2100	3105	-	6210	3.5	P931_0070K402_0250 ME20	3600	3300	5500	≤32	4.6	305
							P931_0070K402_0250 ME30				3500	5000	
194.4	9331/48	2100	3105	-	6210	3.5	P931_0070K402_0280 ME20	3600	3300	5500	≤32	4.7	305
							P931_0070K402_0280 ME30				3500	5000	
235.7	33,712/143	2100	3105	-	5125	3.5	P931_0070K402_0340 ME20	3600	3300	5500	≤24	2.8	305
243.3	29,197/120	2100	3105	-	6210	3.5	P931_0070K402_0350 ME20	3600	3300	5500	≤32	4.5	305
							P931_0070K402_0350 ME30				3500	5000	
283.6	34,314/121	2092	2510	-	4446	3.5	P931_0070K402_0410 ME20	3600	3300	5500	≤24	2.8	305
324.2	4214/13	2100	3105	-	6210	3.5	P931_0070K402_0460 ME20	3600	3300	5500	≤24	2.8	305
353.0	38,829/110	1830	2196	-	3890	3.5	P931_0070K402_0500 ME20	3600	3300	5500	≤24	2.7	305
389.9	17157/44	2100	3105	-	6113	3.5	P931_0070K402_0560 ME20	3600	3300	5500	≤24	2.7	305
485.4	38,829/80	2100	3020	-	5349	3.5	P931_0070K402_0690 ME20	3600	3300	5500	≤24	2.7	305

PK Series: RIGHT ANGLE – Shaft Output

¹⁾ Based on input speed of 1500 RPM. See page 186 for details on torque calculations.

²⁾ Maximum momentary torque for emergency stops or heavy shock load. (Admissible stops per life of gearhead = 1,000 stops maximum.)

* MF = Motor adapter with FlexiAdapt® coupling