

KSS Series: RIGHT ANGLE — Solid Shaft/Hollow Output

“V” Solid Shaft Output with “F” Round Flange Housing

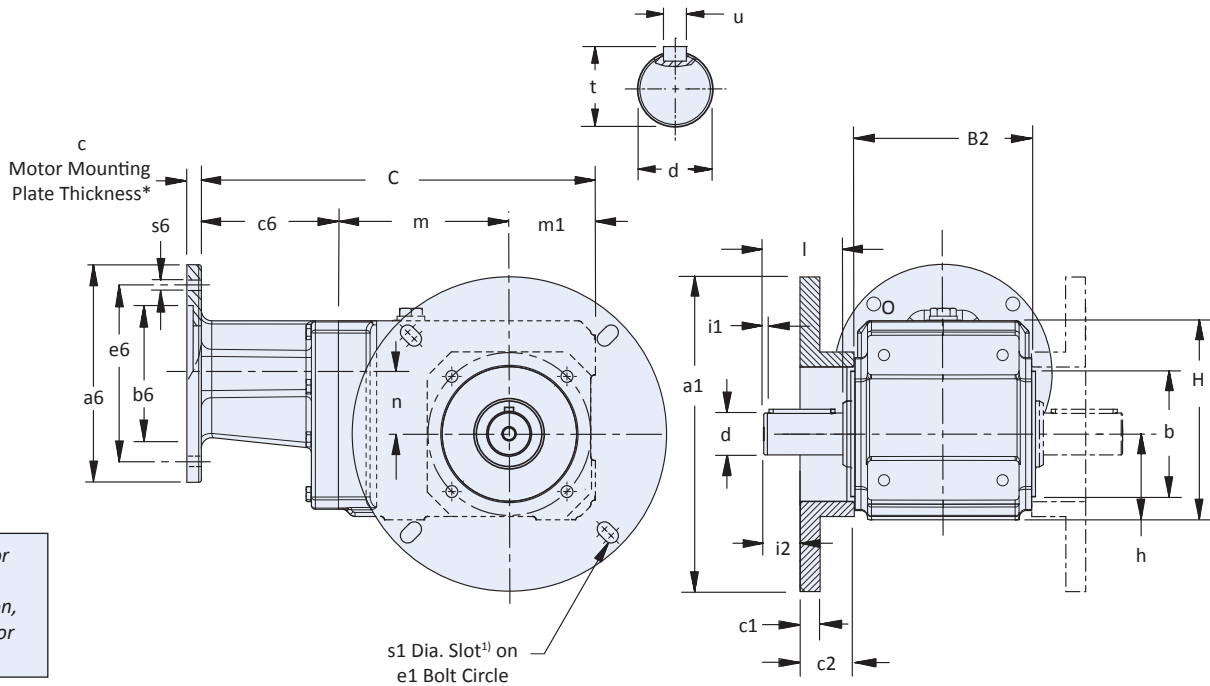

Table 1 KSS Series – “V” Solid Shaft Output with “F” Round Flange Housing – Dimensions (mm)

Unit	a1	B2	b	C	c1	c2	c6	e1	
								Min.	Max. ¹⁾
KSS102VF	171.5	106	75	256.5	14	38.1	82.5	149.2	–
KSS202VF	222	134	95	299	14	38.1	104	190	203.2
KSS302VF	222	146	95	327.5	14	38.1	102.5	190	203.2

1) KSS1 mounting bolt hole is not a slot.

Table 2 KSS Series – “V” Solid Shaft Output with “F” Round Flange Housing – Dimensions (mm)

Unit	H	h	i2	l	l1	m	m1	n	s1	Wt. lbs. ¹⁾
KSS102VF	126	60	20.5	50	4	111	60	36	8.5	29
KSS202VF	151	65	28	60	4	130	65	46	10.5	40
KSS302VF	166.5	75	28	60	4	150	75	53	10.5	55

1) KSS1 mounting bolt hole is not a slot.
All weights are approximate.

Table 3 “V” Solid Shaft Output — Standard Sizes

Unit	Inches		
	d	t	u – Key
KSS1	1.000	1.11	1/4 x 1/4 x 1-9/16
KSS2	1.250	1.36	1/4 x 1/4 x 1-15/16
KSS3	1.250	1.36	1/4 x 1/4 x 1-15/16

Table 4 Servo Motor Adapter Flange (mm)

Unit	a6	b6	e6	s6
KSS1	112	80	100	6.4
	143	110	130	8.4
KSS3	112	80	100	6.4
	143	110	130	8.4
	180	130	165	10.5



Dimensional Data

IP69K/STAINLESS STEEL

“V” Solid Shaft Output with “G” Pitch Circle Diameter (PCD) Tapped Holes

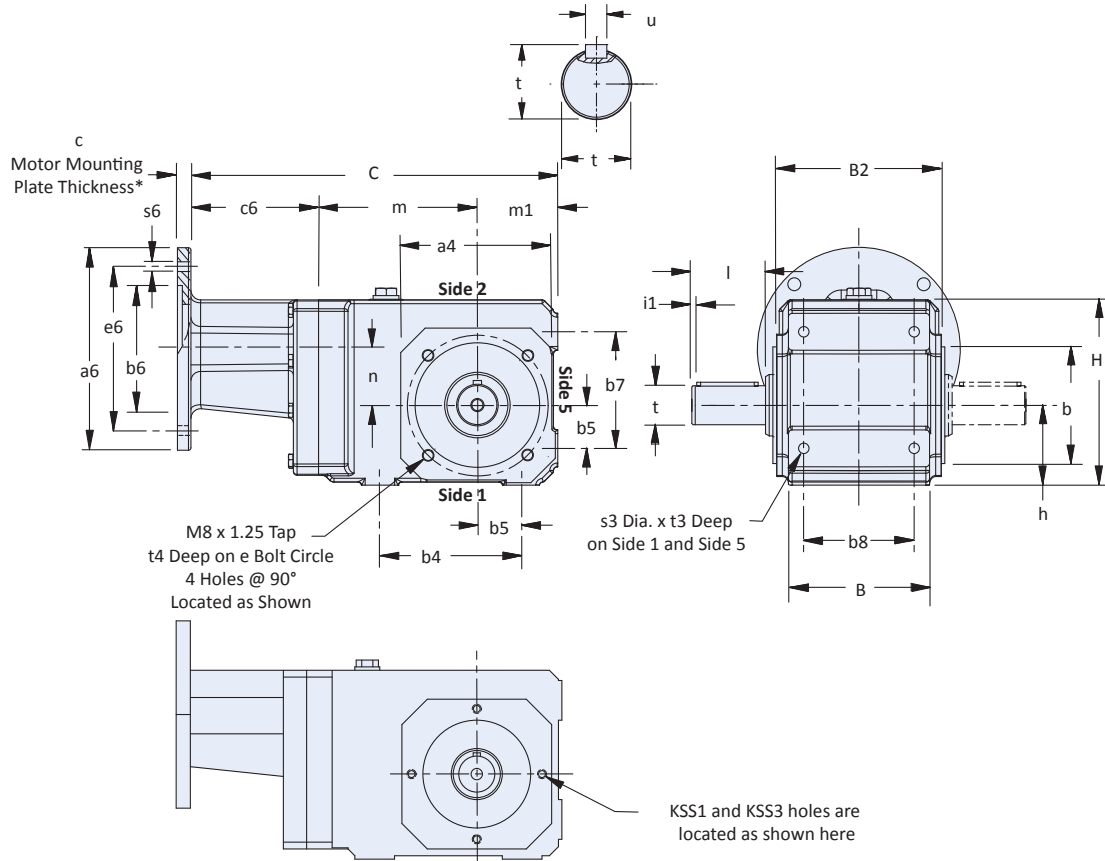

* See Motor Mounting Plate Option, page 275 for details.

Table 1 KSS Series – “V” Solid Shaft Output with “G” Pitch Circle Diameter (PCD) Tapped Holes – Dimensions (mm)

Unit	a4	B2	b5	C	c6	D	e	F ¹	F ⁵	G	H
KSS102VG	105	106	30	256.5	85.5	126	90	90	75	70	60
KSS202VG	116	134	35	299	104	151	115	115	95	90	65
KSS302VG	116	146	35	327.5	102.5	166.5	115	130	105	105	75

Table 2 KSS Series – “V” Solid Shaft Output with “G” Pitch Circle Diameter (PCD) Tapped Holes – Dimensions (mm)

Unit	I	M	m	m1	n	Q	R	s3	t3	t4	Wt. lbs.
KSS102VG	50	75	111	60	36	4	90	M8 x 1.25	13	13	29
KSS202VG	60	95	130	65	46	4	112	M10 x 1.50	16	13	40
KSS302VG	60	95	150	75	53	4	140	M10 x 1.50	16	14	55

All weights are approximate.

Table 3 “V” Solid Shaft Output — Standard Sizes

Unit	Inches		
	d	t	u – Key
KSS1	1.000	1.11	1/4 x 1/4 x 1-9/16
KSS2	1.250	1.36	1/4 x 1/4 x 1-15/16
KSS3	1.250	1.36	1/4 x 1/4 x 1-15/16

Table 4 Servo Motor Adapter Flange (mm)

Unit	a6	b6	e6	s6
KSS1	112	80	100	6.4
	143	110	130	8.4
KSS3	112	80	100	6.4
	143	110	130	8.4
	180	130	165	10.5

KSS Series: RIGHT ANGLE — Solid Shaft / Hollow Output

KSS Series: RIGHT ANGLE — Solid Shaft/Hollow Output

“V” Solid Shaft Output with “NG” Foot Mount Housing

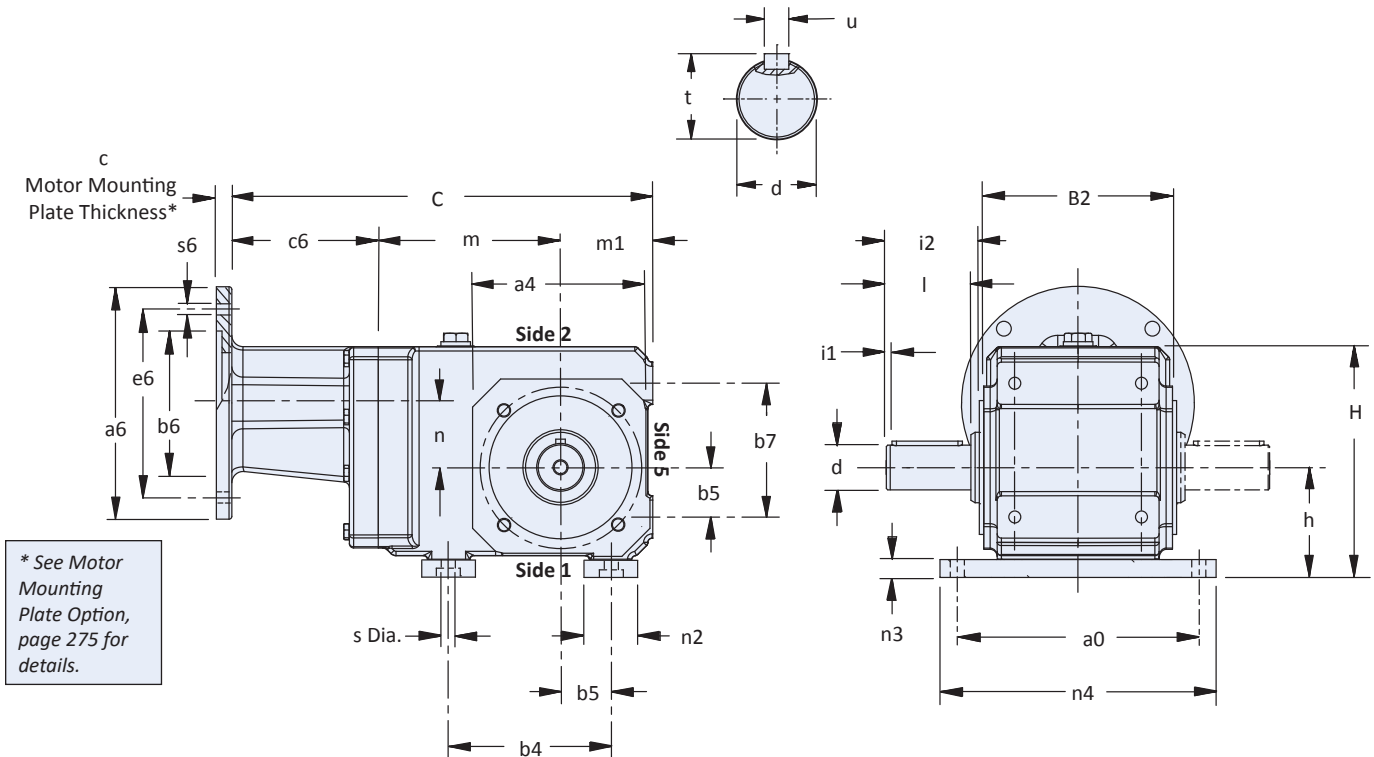

Table 1 KSS Series – “V” Solid Shaft Output with “NG” Foot Mount Housing – Dimensions (mm)

Unit	a0	a4	B2	b4	b5	b7	C	c6	H	h	n4
KSS102VNG	115	115	106	90	30	75	256.5	85.5	126	60	140
KSS202VNG	171	126	134	115	35	95	299	104	164	78	196
KSS302VNG	171	132	146	130	35	105	327.5	102.5	179.5	87.5	196

Table 2 KSS Series – “V” Solid Shaft Output with “NG” Foot Mount Housing – Dimensions (mm)

Unit	i2	l	l1	m	m1	n	n2	n3	s	Wt. lbs.
KSS102VNG	59	50	4	111	60	36	38.1	12.7	8.4	29
KSS202VNG	66	60	4	130	65	46	38.1	12.7	10	40
KSS302VNG	66	60	4	150	75	53	38.1	12.7	10	55

All weights are approximate.

Table 3 “V” Solid Shaft Output — Standard Sizes

Unit	Inches		
	d	t	u – Key
KSS1	1.000	1.11	1/4 x 1/4 x 1-9/16
KSS2	1.250	1.36	1/4 x 1/4 x 1-15/16
KSS3	1.250	1.36	1/4 x 1/4 x 1-15/16

Table 4 Servo Motor Adapter Flange (mm)

Unit	a6	b6	e6	s6
KSS1	112	80	100	6.4
KSS2	112 143	80 110	100 130	6.5 8.4
KSS3	112 143 180	80 110 130	100 130 165	6.4 8.4 10.5



Dimensional Data

IP69K/STAINLESS STEEL

"A" Hollow Bore Output with "F" Round Flange Housing

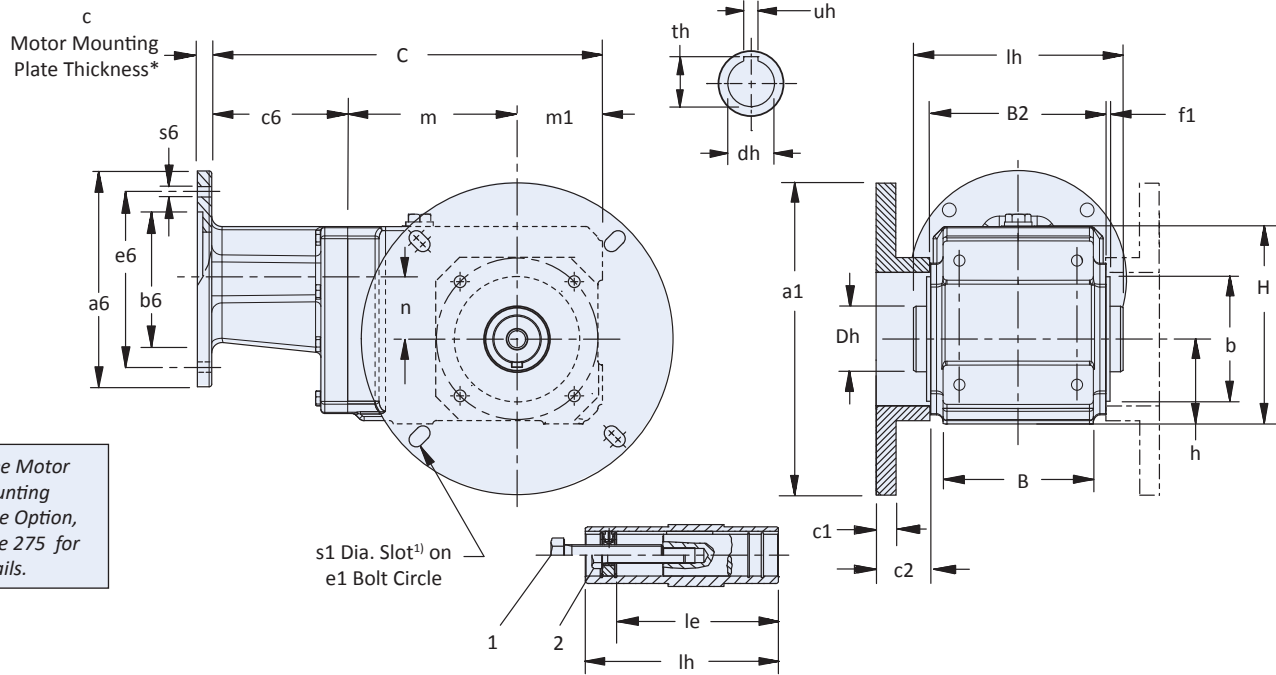

* See Motor Mounting Plate Option, page 275 for details.

1. Removal Bolt — not supplied. Must be smaller than mounting bolt. See Installation Guide for details.
2. Mounting Bolt
See installation guide for installation of hollow output.

Table 1 KSS Series – "A" Hollow Output with "F" Round Flange Housing – Dimensions (mm)

Unit	a1	lh	B	B2	b	C	c1	c2	c6	Dh
KSS102AF	171.5	120	90	106	75	256.5	14	38.1	82.5	40
KSS202AF	222	148	112	134	95	299	14	38.1	104	50
KSS302AF	222	160	140	146	95	327.5	14	38.1	102.5	50

1) KSS1 mounting bolt hole is not a slot

Table 2 KSS Series – "A" Hollow Output with "F" Round Flange Housing – Dimensions (mm)

Unit	e1		f1	h	le	m	m1	n	s1	Wt. lbs.
	Min.	Max. ¹⁾								
KSS102AF	149.2	–	3	60	98	111	60	36	8.5	29
KSS202AF	190	203.2	3	65	113	130	65	46	10.5	40
KSS302AF	190	203.2	3	75	125	150	75	53	10.5	55

1) KSS1 mounting bolt hole is not a slot.
All weights are approximate.

Table 3 "A" Hollow Bore Output — Standard Sizes

Unit	Inches			
	dh	th	UA	1
KSS1	1.000	1.11	0.250	1/2 – 13
KSS2	1.250	1.37	0.250	5/8 – 11
KSS3	1.375	1.52	0.312	5/8 – 11

Table 4 Servo Motor Adapter Flange (mm)

Unit	a6	b6	e6	s6
KSS1	112	80	100	6.4
	143	110	130	8.4
KSS3	112	80	100	6.4
	143	110	130	8.4
	180	130	165	10.5

KSS Series: RIGHT ANGLE — Solid Shaft/Hollow Output

“A” Hollow Bore Output with “G” Pitch Circle Diameter (PCD) Tapped Holes

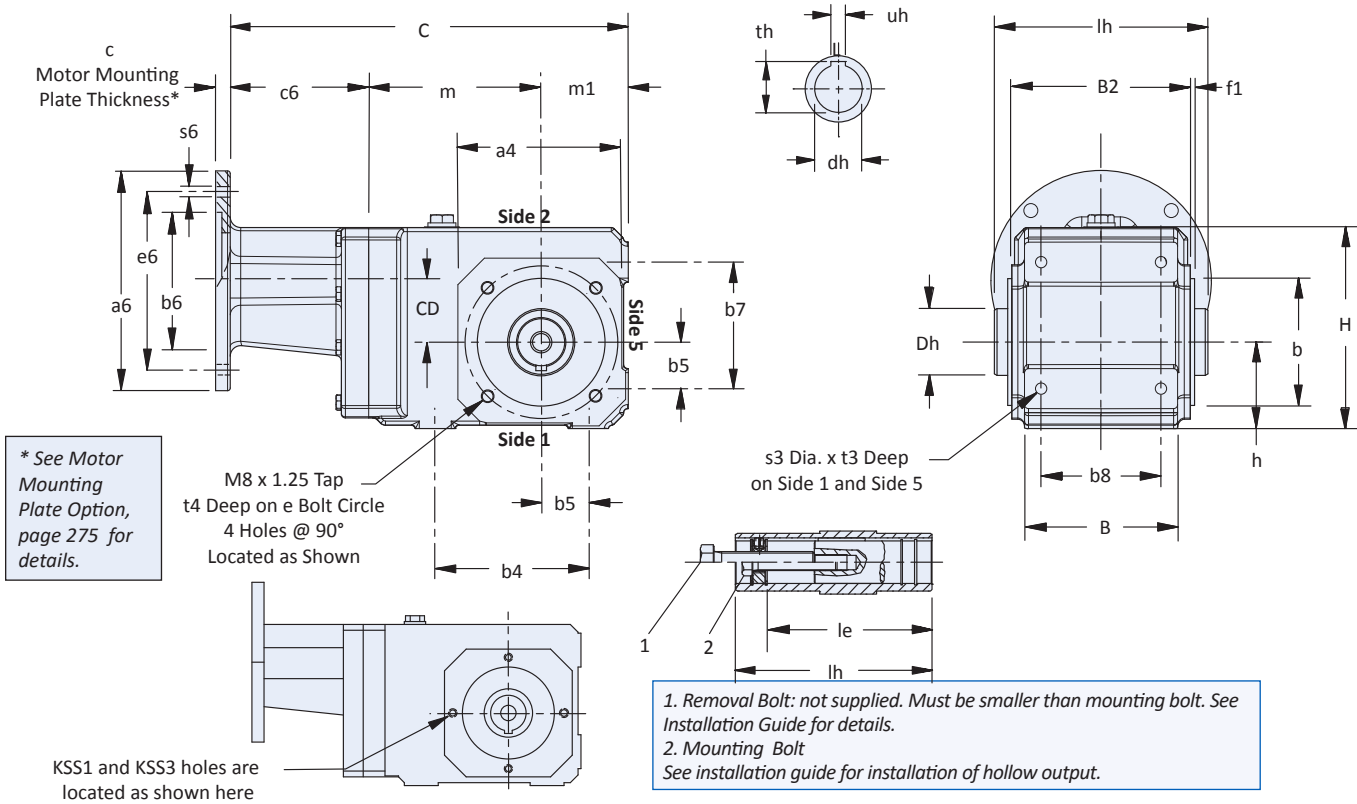

Table 1 KSS Series – “A” Hollow Output with “G” Pitch Circle Diameter (PCD) Tapped Holes – Dimensions (mm)

Unit	a4	B	B2	b	b4	b5	b7	b8	C	c6	Dh	e
KSS102AG	105	90	106	75	90	30	75	70	256.5	85.5	40	90
KSS202AG	116	112	134	95	115	35	95	90	299	104	50	115
KSS302AG	116	140	146	95	130	35	105	105	327.5	102.5	50	115

Table 2 KSS Series – “A” Hollow Output with “G” Pitch Circle Diameter (PCD) Tapped Holes – Dimensions (mm)

Unit	f1	H	h	le	lh	m	m1	n	s3	t3	t4	Wt. lbs.
KSS102AG	3	126	60	98	120	111	60	36	M8 x 1.25	13	13	29
KSS202AG	3	151	65	113	148	130	65	46	M10 x 1.50	16	13	40
KSS302AG	3	166.5	75	125	160	150	75	53	M10 x 1.50	16	14	55

1) Removal bolt, supplied by customer, must be smaller than mounting bolt. See Page 298.
All weights are approximate.

Table 3 “A” Hollow Bore Output — Standard Sizes

Unit	Inches			
	dh	th	UA	1
KSS1	1.000	1.11	0.250	1/2 – 13
KSS2	1.250	1.37	0.250	5/8 – 11
KSS3	1.375	1.52	0.312	5/8 – 11

Table 4 Servo Motor Adapter Flange (mm)

Unit	a6	b6	e6	s6
KSS1	112	80	100	6.4
KSS2	112	80	100	6.5
	143	110	130	8.4
KSS3	112	80	100	6.4
	143	110	130	8.4
	180	130	165	10.5



Dimensional Data

IP69K/STAINLESS STEEL

“W” Double Bushing Output with “G” Pitch Circle Diameter (PCD) Tapped Holes

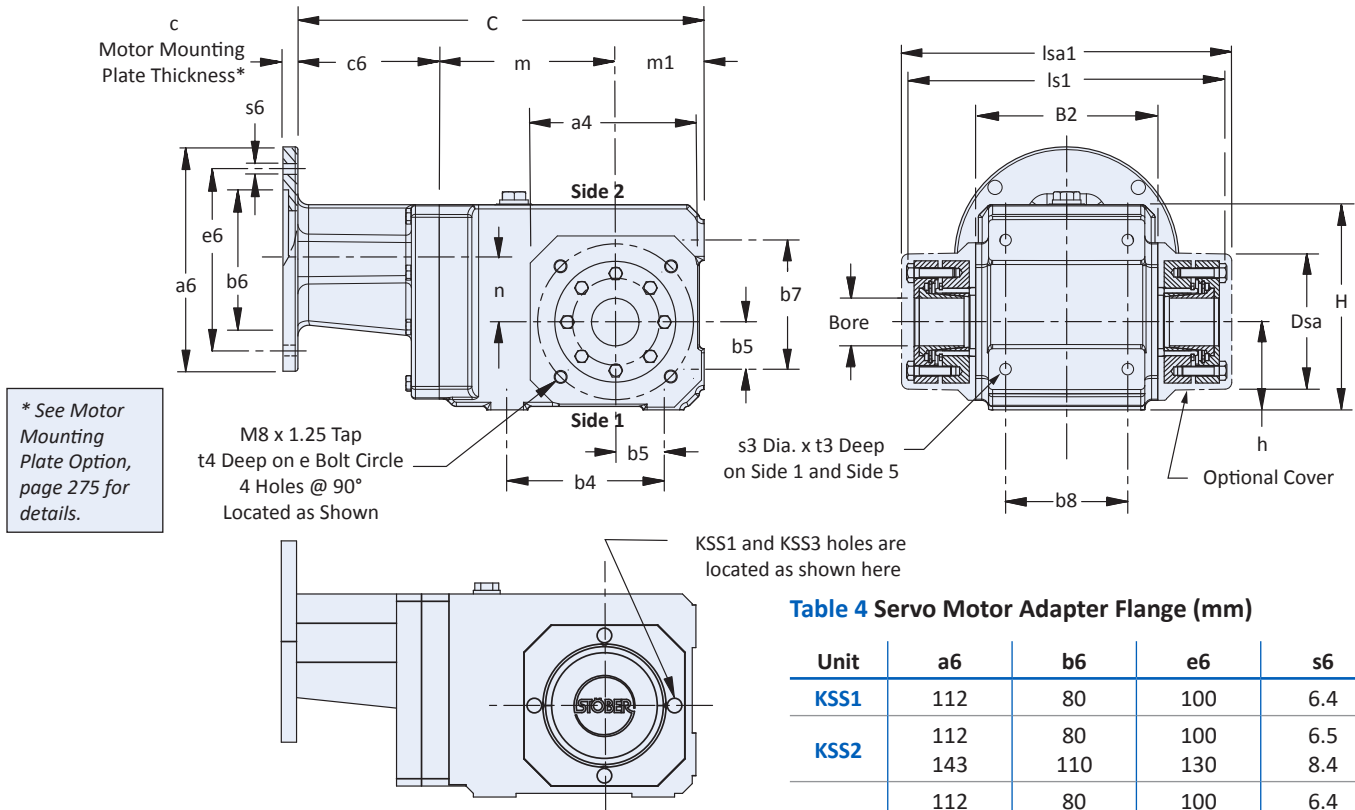

Table 4 Servo Motor Adapter Flange (mm)

Unit	a6	b6	e6	s6
KSS1	112	80	100	6.4
KSS2	112	80	100	6.5
	143	110	130	8.4
KSS3	112	80	100	6.4
	143	110	130	8.4
	180	130	165	10.5

Table 1 KSS Series – “W” Double Wobble-Free Bushing Output with “G” Pitch Circle Diameter (PCD) Tapped Holes – Dimensions (mm)

Unit	a4	B2	b4	b5	b7	b8	C	c6	Dsa	e
KSS102WG	105	105.9	90	30	75	70	256.5	85.5	78	90
KSS202WG	116	134.1	115	35	95	90	299	104	99.5	115
KSS302WG	116	146.1	130	35	105	105	327.5	102.5	96	115

Table 2 KSS Series – “W” Double Wobble-Free Bushing Output with “G” Pitch Circle Diameter (PCD) Tapped Holesg – Dimensions (mm)

Unit	H	h	lsa	ls1	m	m1	n	s3	t3	t4	Wt. lbs.
KSS102WG	126	60	198.12	194.06	111	60	36	M8 x 1.25	13	13	29
KSS202WG	151	65	237.74	226.06	130	65	46	M10 x 1.50	16	13	40
KSS302WG	166.5	75	252.73	239.014	150	75	53	M10 x 1.50	16	14	55

All weights are approximate.

Table 3 “WFBSS” Double Side Bushings Stock Bore Sizes

Unit	Inches					
	1	1-3/16	1-1/4	1-3/8	1-7/16	1-1/2
KSS1	WFBSS1-100	—	—	—	—	—
KSS2	WFBSS2-100	WFBSS2-103	WFBSS2-104	WFBSS2-106	WFBSS2-107	WFBSS2-108
KSS3	WFBSS3-100	WFBSS3-103	WFBSS3-104	WFBSS3-106	WFBSS3-107	WFBSS3-108