

# PHQ Series: RIGHT ANGLE – Flange Output

## PHQ Series Dimensions – All Units

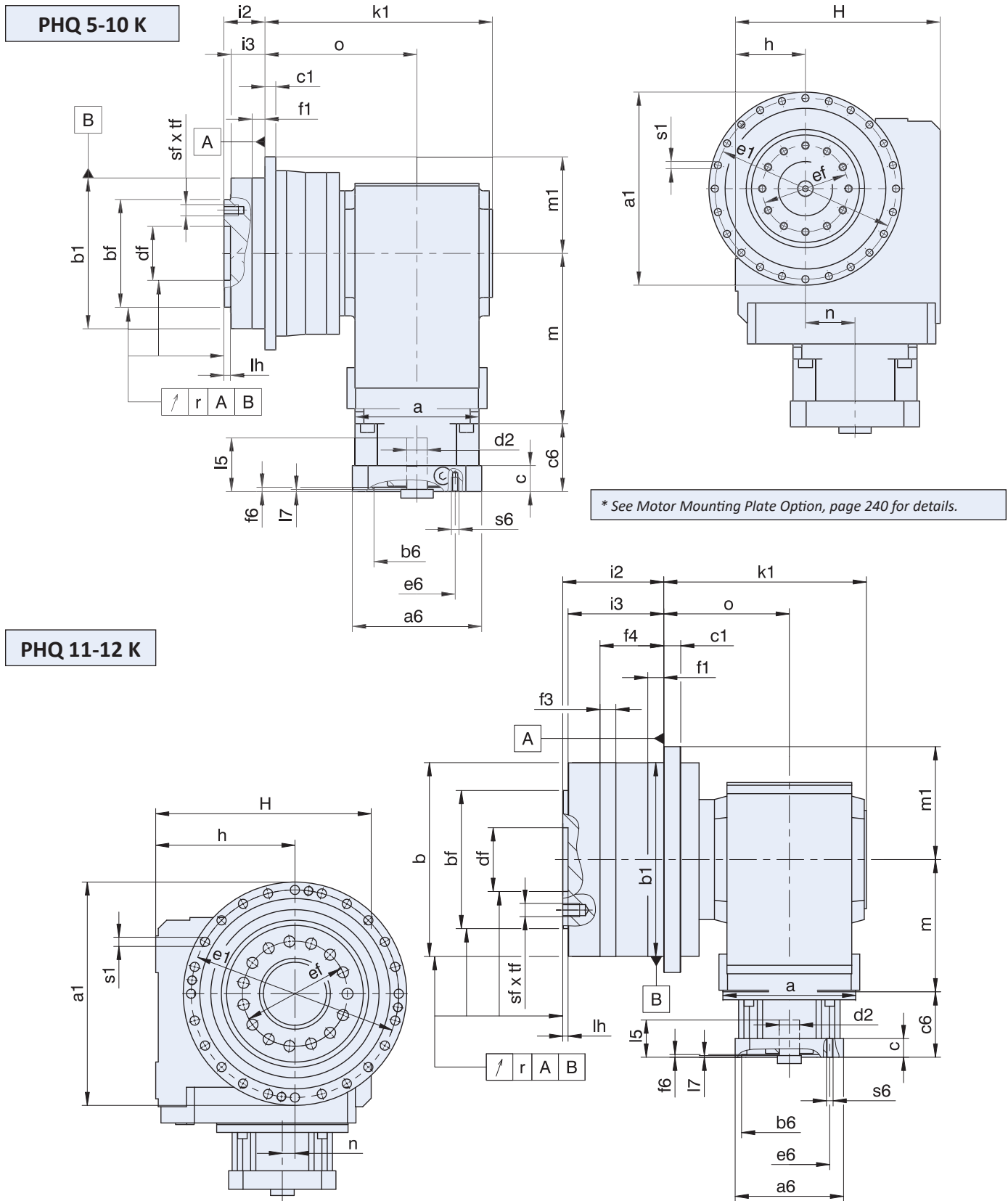

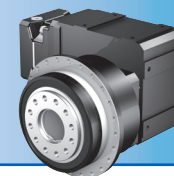

# Dimensional Data

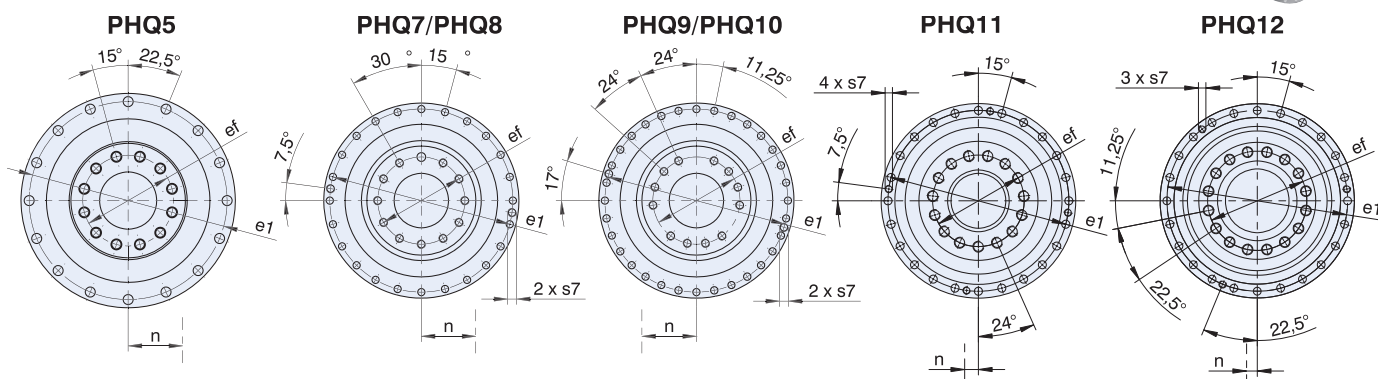

**Table 1 Dimensions (mm)**

Unit	Øa1	Øb	Øb1	Øbf	c1	Ødf	Øe1	Øef	f1	f3	f4	h	H	i2	i3	k1	lh	m1	o	r	Øs1	s7	sf	tf
PHQ531_K102	145	-	110 <sup>h7</sup>	80 <sup>h7</sup>	8	40 <sup>H6</sup>	135	63	12	-	-	60	160	29	23	180.0	6	72.5	124.0	0.020	5.5	-	M8	12
PHQ731_K202	179	-	140 <sup>h7</sup>	100 <sup>h7</sup>	10	50 <sup>H6</sup>	168	80	12	-	-	65	190	38	32	211.0	6	89.5	141.0	0.025	6.6	-	M10	16
PHQ831_K402	247	-	200 <sup>h7</sup>	160 <sup>h7</sup>	12	80 <sup>H6</sup>	233	125	15	-	-	90	240	50	42	289.0	8	123.5	199.0	0.030	9.0	M10	M12	17
PHQ941_K513	300	-	255 <sup>h7</sup>	180 <sup>h7</sup>	18	90 <sup>H6</sup>	280	145	20	-	-	160	260	66	55	292.5	12	150.0	196.5	0.030	13.5	M8	M20	28
PHQ1041_K713	330	-	285 <sup>h7</sup>	200 <sup>h7</sup>	20	95 <sup>H6</sup>	310	166	20	-	-	212	342	75	60	354.5	10	165.0	238.0	0.040	13.5	M10	M24	35
PHQ1141_K813	425	365 <sup>h6</sup>	365 <sup>h6</sup>	260 <sup>h7</sup>	32	120 <sup>H6</sup>	395	200	30	30	120	265	410	190	180	381.5	10	212.5	236.5	0.040	17.5	M16	M24	35.5
PHQ1241_K913	550	470 <sup>h6</sup>	470 <sup>h6</sup>	330 <sup>h7</sup>	45	180 <sup>H7</sup>	510	280	30	30	145	315	495	206.5	195.5	452.0	10	275.0	282.0	0.040	22.0	M16	M30	47
PHQ1241_K914	550	470 <sup>h6</sup>	470 <sup>h6</sup>	330 <sup>h7</sup>	45	180 <sup>H7</sup>	510	280	30	30	145	315	495	206.5	195.5	452.0	10	275.0	282.0	0.040	22.0	M16	M30	47

## Motor Mounting Plate

**Table 2 Dimensions (mm)**

Base Module	Motor Adapter Code															Wt. lbs.
	ME10			ME20			ME30			ME40			ME50			
	a	m	n	a	m	n	a	m	n	a	m	n	a	m	n	
PHQ531_K102	98	124	36	115	128	36	-	-	-	-	-	-	-	-	-	43
PHQ731_K202	98	143	46	115	147	46	145	149	46	-	-	-	-	-	-	69
PHQ831_K402	-	-	-	160	187	60	145	189	60	190	192	60	-	-	-	116
PHQ941_K513	-	-	-	160	172	15	145	174	15	190	177	15	-	-	-	213
PHQ1041_K713	-	-	-	-	-	-	200	221	20	190	224	20	300	237	20	310
PHQ1141_K813	-	-	-	-	-	-	200	247	24	250	249	24	300	262	24	
PHQ1241_K913	-	-	-	-	-	-	-	-	-	250	294	25	300	307	25	
PHQ1241_K914	-	-	-	-	-	-	200	353	25	250	365	25	-	-	-	

PHQK Series: RIGHT ANGLE – Flange Output