

KS Series: RIGHT ANGLE – Versatile Outputs

KS Features

- 6:1 to 200:1 ratios (higher ratios available. Contact STÖBER.)
- Quiet running (<62dB(A))
- Flexibility for mounting
- Adaptability: shafts available in metric and imperial to meet your requirements
- Large motor input option to accept bigger diameter motor shafts so you don't use an oversized gearbox
- Error free motor mounting and quick changeover with toleranced pilot on motor plate
- Low no load running torque, giving you more torque for your application
- Magnetic oil filtration to remove contaminants to prevent breakdowns
- Build and ship in one day
- Assembled in the USA

STÖBER KS Series uses helical and bevel gearing to provide a low backlash unit, that is smooth running, with high efficiency, high power density, and high input speed capacity. The KS also offers flexibly with three output options: shaft, flange, and hollow. Every gearbox is made to order. STÖBER will custom whatever you need to fit your application. Contact us today to learn more.

**SHIPS in
1 DAY!**
NO EXPEDITE FEE FOR 24
HOUR SERVICE

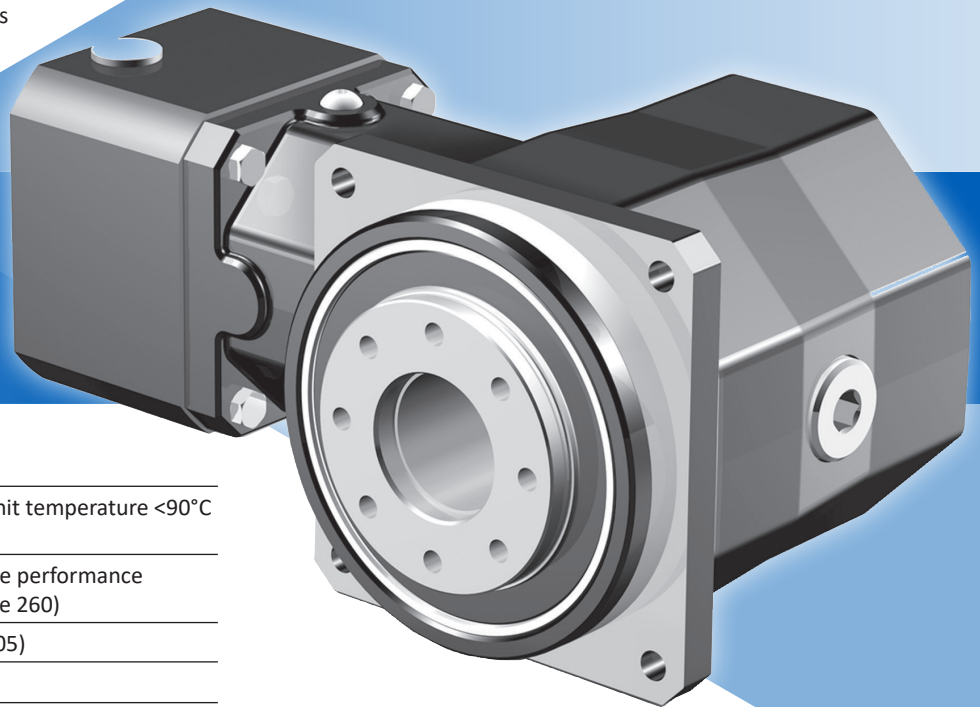

General Specifications

Ambient Temperature	0°C to +40°C (104°F) [Unit temperature <90°C Max]
Backlash	≤4 standard arcmins (see performance overview chart, see page 260)
Coating	Standard Black (RAL-9005)
Degree of Protection	IP65
Direction of Rotation	Input and output rotate the SAME direction (see page 260)
Efficiency	2 stage 95%; 3 stage 93%;
Input RPM	Up to 6,000 RPM
Installation	Requires 12.9 fasteners for tapped holes housing. See page 288, for more information
Lubrication	Lubricated for life – standard Mobil SHC629; option food grade Mobil SHC CIBUS 150
Mounting Position	Must be specified, see page 261
Warranty	5 Year Limited (2 Years on normal wear items: bearings, seals, etc.)

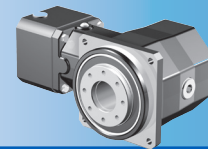

Overview

Selection Options At-a-Glance

Using the **Selection Data** table later in this section, select the KS Series Gearhead with the appropriate performance and design options tailored to your motor choice and exact application requirements. Use the part number guide below as a reference to build a part number for the complete gearhead assembly.

Part Number Examples: 1 2 3 4 5 6 7 8 9 KS 4 0 2 P F 0060 ME L EL1 *

Design Option	Part Number Code	Description
1 Series	KS	Concentric helical
2 Size	4 5 7	3 sizes of gearhead
3 Generation	0	Version of gearhead
4 # of Stages	2	Two stage for ratios ≤20:1
	3	Three stage for ratios >20:1
5 Output	P	Shaft with key
	G	Plain shaft (no key)
	F	Flanged hollow
	S	Shrink ring
6 Housing	F	Standard
7 Ratio	0060	Ratios range from 6:1 to 200:1 (0060=6:1; 0200=20:1; 2000=200:1)
8 Motor Adapter	ME	ME Motor adapter (See also motor mounting plate option, page 261)
0 Options	L	Large Input
* Mounting Position	EL1 EL2 EL3 EL4 EL5 EL6	Required special instruction for all units, see page 261

KS Series: RIGHT ANGLE – Versatile Outputs

Options

Coating Option

- Available with multi-layer, industrial 316 stainless steel epoxy coating. Contact factory for this option.

Large Input

- Accommodates a larger diameter motor shaft without going to a larger size gearbox.

ATEX

- ATmosphere EXplosible – rated for explosive environments. Contact factory for this option and allow additional time for delivery.

Oil Reservoir

- Use with 3 stage units (for vertical EL5 orientation, see page 260).

KS Series: RIGHT ANGLE – Versatile Outputs

KS Performance Overview

KS Series performance is dependent on several factors including duty cycle, bearing design, gearhead size and stage configuration, among others. Use the chart below for preliminary evaluation, then use the following performance chart and selection information on the following pages for specific performance sizing and selection.

Size/Generation		KS40		KS50		KS70		
		2	3	2	3	2	3	
Acceleration Torque	M_{2BMAX}	Nm		90	200	400		
Output Torque Nom.	$^1) M_{2N}$	Nm		65	125	250		
Torsional Stiffness	C_2	Nm/arcmin		≤8.5	≤17	≤42		
Torsional Backlash	$^2) \Delta\phi$	arcmin		≤6	≤5	≤4		
Input Speed Max.	n_{1MAX}	Continuous	4000	4500	3500	4200	3200	4000
		Cyclic	6000	6000	6000	6000	6000	6000
Efficiency (@nom torque)	%	95	93	95	93	95	93	
Weight	kg	8.4	8.2	13.6	14.4	26.8	28.1	
	lbs	18.5	18.1	30	31.8	59.1	62	
Noise	$^3)$ dB(A)	≤65		≤62		≤63		

Performance by Output Option (P = Shaft with Key; G = Shaft without Key; F = Flanged Hollow Output; S = Shrink Ring)⁴⁾

Size/Generation			KS40	KS50	KS70
Axial Load Max.	P/G	N	3400	6000	10,000
	F	N	4000	6000	10,000
	S	N	4000	6000	10,000
Radial Load Max.	P/G	N	5000	8000	10,000
Tilting Moment Max.	F/S	Nm	210	460	780

¹⁾ Ratings based on input speed (n_1) of 1500 RPM.

$$M_{2NX} = \frac{M_{2N}}{\left(\frac{n_1}{1500}\right)^3}$$

For torque at higher input speeds (M_{2NX}) solve the formula:
where n_1 = Actual Input Speed.

²⁾ Tested at 1.5% of nominal torque and recorded on the output side of the gearhead. For lower backlash, contact STÖBER technical support.

³⁾ Measurement at one (1) meter distance with input speed (n_1) of 2000 RPM.

⁴⁾ Rating based on output speed (n_2) of 100 RPM. For values at other speeds see page 262.

KS Direction of Rotation

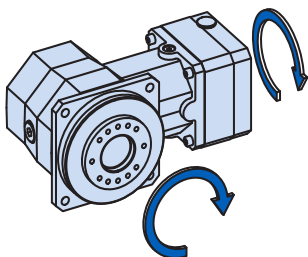

Oil Reservoir Orientation

For 3 stage units in vertical EL5 mounting position — not available with large input option

When ordering, Side 1 or Side 2 MUST BE SPECIFIED.

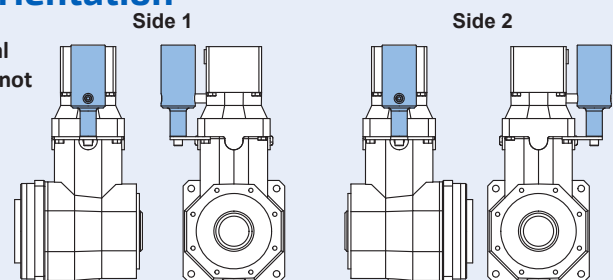

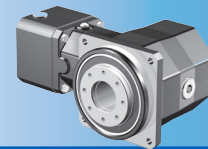

Overview

KS Series Motor Mounting Plate Option (Motor information required with Motor Adapter ME option)

STÖBER Servo Gearheads fit the motor of your choice with the appropriate motor mounting plate assembled between the motor and the gearhead.

NOTE: When ordering a gearhead:

- Specify the motor manufacturer and part number
- Provide the motor drawing with dimensions, or specify the motor mounting dimensions (per the list shown at right)

For a precise dimension on a specific motor, or for general assistance, we recommend you contact STÖBER Technical Support.

Customer Required Dimensions for Properly Sized Motor Mounting Plate

d2	Motor Shaft Diameter (If an adapter bushing is required it will be supplied with the motor plate.)
b6	Pilot Diameter
e6	Bolt Circle Diameter
s6	Bolt Diameter
l5	Motor Shaft Length
f6	Pilot Length
a6	Square Flange (Optional – motor plate will typically be made to match this dimension.)

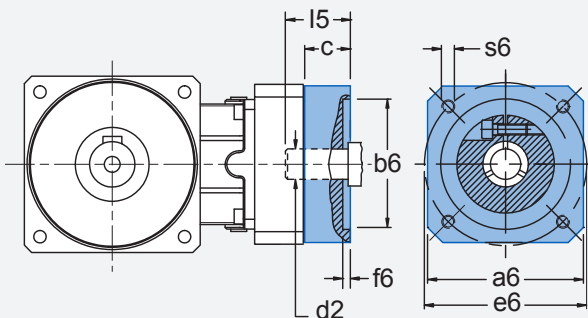

Motor Mounting Plate Dimensions — mm (Gearhead Part Number Specific)

	KS403	KS402 KS403...L KS503	KS402...L KS502 KS503...L KS703	KS502...L KS702 KS703...L	KS702...L
Maximum Allowed Motor Shaft Dia. d2	14	19	24	32	38
Minimum Allowed Motor Plate Thickness c	15	18	21	24	25

* Note that the c motor plate thickness is determined by the motor shaft length. The minimum motor plate thickness is the value listed.

KS Series Motor Mounting Plate Access Hole

Access to the clamping screw for the motor coupling is located on the 270° side of the motor mounting plate at the location shown. If necessary, the motor mounting plate can be rotated in the field, if a 0°, 90° or 180° orientation for the access hole is desirable.

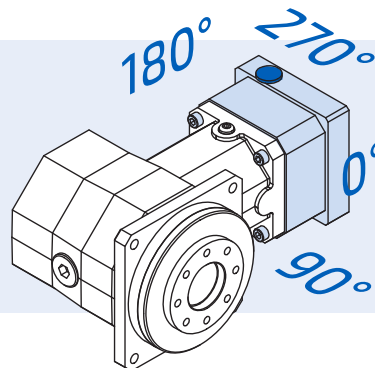

KS Mounting Position Options

KS Units can be mounted in any of the positions illustrated below.

When ordering KS units mounted in a vertical position (EL3) or in a horizontal position (EL5), the mounting position **MUST BE SPECIFIED**. NOTE: EL5 3 stage units are only available with the oil reservoir option.

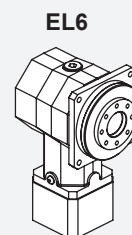
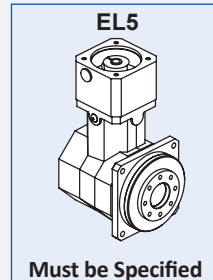
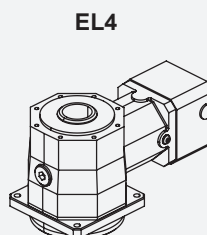
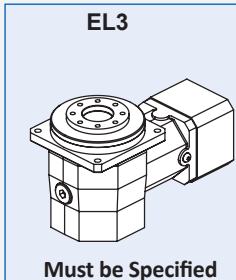
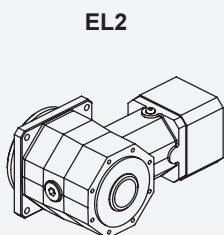
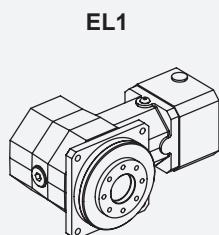

KS Series: RIGHT ANGLE – Versatile Outputs

KS Series: RIGHT ANGLE – Versatile Outputs

Permissible Motor Tilting Torque

The permissible tilting torque of the motor attached to the gear unit is a result of the static and dynamic load “F” from the motor weight, mass acceleration, and vibration multiplied by the distance from the center of gravity “l_s” of the motor.

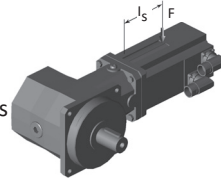

$$M_{1k} = F \times l_s \leq M_{1K}$$

M _{1K}	KS403	KS402 KS503	KS502 KS703	KS702
Nm	10	20	40	80

Permissible Output Shaft Load and Tilting Moments*

Unit	Z ₂ mm	F _{2A} N	F _{2R} N	F _{2RB} N	M _{2K} Nm	M _{2KB} Nm
P/G Solid Shaft (with/without key)						
KS4	34	3400	5000	5000	260	260
KS5	40	6000	8000	8000	550	550
KS7	51	10,000	10,000	10,000	920	920
F Flange Hollow Output						
KS4	38	4000	6842	10,263	260	390
KS5	45	6000	12,222	18,333	550	825
KS7	55	10,000	16,727	25,091	920	1380
S Hollow Output with Shrink Ring						
KS4	36	4000	5000	5000	260	260
KS5	42	6000	8000	8000	550	550
KS7	52	10,000	10,000	10,000	920	920

* Refer to illustration and definitions below.

During EMERGENCY OFF operation (maximum stops per gearhead = 1000) the permissible values in the table for F_{2A}, F_{2R} and M_{2K} can be multiplied by a factor of 2.

KS Series Load/Life/Speed Calculations

The permissible load and tilting moment values are based on an output speed of 100 RPM. For higher speeds the following applies, where n₂ is the desired speed:

$$F_{2axN} = \frac{F_{2ax100}}{\sqrt[3]{\frac{n_{2m} \cdot t_{1m}}{100 \text{ rpm}}}}, \quad F_{2radN} = \frac{F_{2rad100}}{\sqrt[3]{\frac{n_{2m} \cdot t_{1m}}{100 \text{ rpm}}}}, \quad M_{2kN} = \frac{M_{2k100}}{\sqrt[3]{\frac{n_{2m} \cdot t_{1m}}{100 \text{ rpm}}}}$$

The application output tilting moment should be determined by the following formula:

$$\text{Output P \& G} \quad M_{2k,acc} = \frac{2 \cdot F_{2ax100} \cdot y_2 + F_{2rad,acc} \cdot (x_2 + Z_2)}{1000} \leq M_{2k,acc}$$

$$\text{Output F \& S} \quad M_{2k,acc} = \frac{F_{2ax100} \cdot y_2 + F_{2rad,acc} \cdot (x_2 + Z_2)}{1000} \leq M_{2k,acc}$$

$$M_{2k,eq} = \sqrt[3]{\frac{n_{2m,1} \cdot t_{1m} \cdot M_{2k,acc,1}^3 + \dots + n_{2m,n} \cdot t_{1m} \cdot M_{2k,acc,n}^3}{n_{2m,1} \cdot t_{1m} + \dots + n_{2m,n} \cdot t_{1m}}} \leq M_{2kN}$$

$$F_{2ax,eq} = \sqrt[3]{\frac{n_{2m,1} \cdot t_{1m} \cdot F_{2rad,acc,1}^3 + \dots + n_{2m,n} \cdot t_{1m} \cdot F_{2rad,acc,n}^3}{n_{2m,1} \cdot t_{1m} + \dots + n_{2m,n} \cdot t_{1m}}} \leq F_{2radN}$$

Where:

Z ₂	Distance of Shaft Shoulder to Center of Output Bearing	F _{2rad100}	Permitted Radial Force ≤100RPM
n ₂	Actual Average Output Speed	F _{2rad,acc}	Radial Acceleration Force
x ₂	Distance of the Shaft Shoulder to the Force Application Point	F _{2rad,acc*}	Radial Acceleration Force at Gear Unit Output
y ₂	Distance of the Shaft Axis to the Axial Force Application Point	M _{2K100}	Permitted Tilting Torque ≤100RPM
F _{2ax*}	Actual Axial Force at Gear Unit Output	M _{2K,acc}	Permitted Acceleration Tilting Torque
F _{2ax100}	Permitted Axial Force	M _{2k,acc*}	Permitted Acceleration Tilting Torque at Gear Unit Output
		C _{2K}	Tilting Stiffness

The hours of life (L_h) of the unit can be determined by the following formula:

bearing life for duty cycle ≤ 40%

$$L_h > 10,000 \text{ hours if } M_{2k100}/M_{2A*} < 1.25 \text{ and } > 1$$

$$L_h > 20,000 \text{ hours if } M_{2k100}/M_{2A*} > 1.25 \text{ and } > 1.5$$

$$L_h > 30,000 \text{ hours if } M_{2k100}/M_{2A*} < 1.5$$

bearing life for duty cycle ≥ 40%

$$L_{hA} = L_h \left(\frac{40\%}{\text{Duty Cycle}} \right)$$

All formulas shown are based on METRIC values
Upper case letters are permissible values. Lower case letters are for existing values.

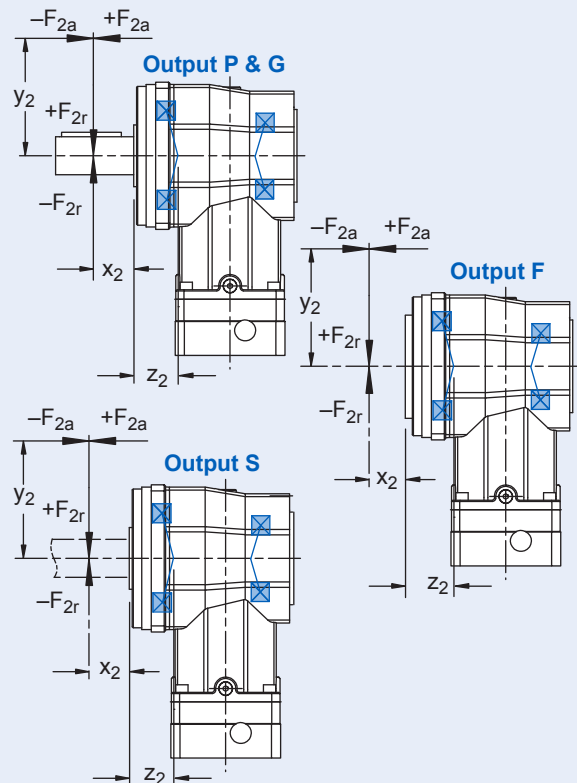

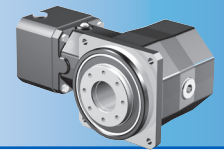

Selection Data

Exact Ratio (i)	Output Torque			Backlash $\Delta\phi_2$	Part Number* (Gearhead + Input)	Max. Input Speed RPM (n1)		Motor Shaft Max ϕ d_{MW}	Input Inertia J_1	Tors. Stiffness C_2
	Nom. ¹⁾ M_{2N}	Accel. M_{ZACC}	Peak ²⁾ M_{2NOT}			Cont.	Cyclic			
	Nm	Nm	Nm							

KS4

6.000	60	90	140	6	KS402_0060ME	3000	6000	19	1.1	8.1
					KS402_0060MEL			24	1.5	8.4
8.000	65	90	140	6	KS402_0080ME	3500	6000	19	0.7	8.3
					KS402_0080MEL			24	1.2	8.4
10.00	65	90	140	6	KS402_0100ME	3800	6000	19	0.6	8.3
					KS402_0100MEL			24	1.1	8.4
14.00	65	90	140	6	KS402_0140ME	4000	6000	19	.47	8.4
					KS402_0140MEL			24	0.96	8.5
20.00	60	90	140	6	KS402_0200ME	4000	6000	19	0.43	8.5
					KS402_0200MEL			24	0.9	
24.00	60	90	140	6	KS403_0240ME	3500	6000	14	0.2	8.5
					KS403_0240MEL			19	0.5	
32.00	65	90	140	6	KS403_0320ME	3500	6000	14	0.2	8.5
					KS403_0320MEL			19	0.5	
40.00	65	90	140	6	KS403_0400ME	3500	6000	14	0.2	8.5
					KS403_0400MEL			19	0.5	
50.00	65	90	140	6	KS403_0500ME	4000	6000	14	0.1	8.5
					KS403_0500MEL			19	0.4	
70.00	65	90	140	6	KS403_0700ME	4500	6000	14	0.1	8.5
					KS403_0700MEL			19	0.4	
80.00	65	90	140	6	KS403_0800ME	4500	6000	14	0.1	8.5
					KS403_0800MEL			19	0.4	
100.0	65	90	140	6	KS403_1000MET	4500	6000	14	0.1	8.5
					KS403_1000MEL			19	0.4	
140.0	65	90	140	6	KS403_1400ME	4500	6000	14	0.1	8.5
					KS403_1400MEL			19	0.4	
200.0	60	90	140	6	KS403_2000ME	4500	6000	14	0.1	8.5
					KS403_2000MEL			19	0.4	

KS Series: RIGHT ANGLE – Versatile Outputs

¹⁾ Based on input speed of 2000 RPM. See page 260 for details on torque calculations.

²⁾ Maximum momentary torque for emergency stops or heavy shock load. (Admissible stops per life of gearhead = 1,000 stops maximum.)

³⁾ Inertia based on maximum input. For lower inertia, using smaller diameter input, contact STÖBER.

* MT = Motor Adapter L = Large Input Option

KS Series: RIGHT ANGLE – Versatile Outputs

Exact Ratio (i)	Output Torque			Backlash $\Delta\phi_2$ arcmin	Part Number* (Gearhead + Input)	Max. Input Speed RPM (n1)		Motor Shaft Max ϕ d_{MW} mm	Input Inertia ³⁾ J_1 kgcm ²	Tors. Stiffness C_2 Nm/arcmin
	Nom. ¹⁾ M_{2N}	Accel. M_{2ACC}	Peak ²⁾ M_{2NOT}			Cont.	Cyclic			
	Nm	Nm	Nm							

KS5

6.000	100	200	300	5	KS502_0060ME	2500	5500	24	2.5	16.0
					KS502_0060MEL			32	4.1	17.0
8.000	125	200	300	5	KS502_0080ME	2800	6000	24	1.9	17.0
					KS502_0080MEL			32	3.5	
10.00	125	200	300	5	KS502_0100ME	3000	6000	24	1.5	17.0
					KS502_0100MEL			32	3.1	
14.00	125	200	300	5	KS502_0140ME	3200	6000	24	1.1	17.0
					KS502_0140MEL			32	2.8	
20.00	120	200	300	5	KS502_0200ME	3500	6000	24	1.0	17.0
					KS502_0200MEL			32	2.6	
24.00	100	200	300	5	KS503_0240ME	3100	6000	19	0.6	17.0
					KS503_0240MEL			24	1.1	
32.00	125	200	300	5	KS503_0320ME	3100	6000	19	0.6	17.0
					KS503_0320MEL			24	1.1	
40.00	125	200	300	5	KS503_0400ME	3100	6000	19	0.6	17.0
					KS503_0400MEL			24	1.1	
50.00	125	200	300	5	KS503_0500ME	3500	6000	19	0.5	17.0
					KS503_0500MEL			24	1.0	
70.00	125	200	300	5	KS503_0700ME	4200	6000	19	0.4	17.0
					KS503_0700MEL			24	0.9	
80.00	125	200	300	5	KS503_0800ME	4200	6000	19	0.4	17.0
					KS503_0800MEL			24	0.9	
100.0	125	200	300	5	KS503_1000ME	4200	6000	19	0.4	17.0
					KS503_1000MEL			24	0.9	
140.0	125	200	300	5	KS503_1400ME	4200	6000	19	0.4	17.0
					KS503_1400MEL			24	0.9	
200.0	120	200	300	5	KS503_2000ME	4200	6000	19	0.4	17.0
					KS503_2000MEL			24	0.9	

¹⁾ Based on input speed of 2000 RPM. See page 260 for details on torque calculations.

²⁾ Maximum momentary torque for emergency stops or heavy shock load. (Admissible stops per life of gearhead = 1,000 stops maximum.)

³⁾ Inertia based on maximum input. For lower inertia, using smaller diameter input, contact STÖBER.

* MT = Motor Adapter L = Large Input Option

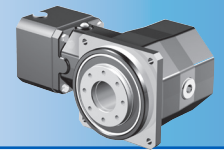

Selection Data

Exact Ratio (i)	Output Torque			Backlash $\Delta\phi_2$ arcmin	Part Number* (Gearhead + Input)	Max. Input Speed RPM (n1)		Motor Shaft Max ϕ d_{MW} mm	Input Inertia ³⁾ J_1 kgcm ²	Tors. Stiffness C_2 Nm/arcmin
	Nom. ¹⁾ M_{2N} Nm	Accel. M_{ZACC} Nm	Peak ²⁾ M_{2NOT} Nm			Cont.	Cyclic			

KS7

6.000	240	400	600	4	KS702_0060ME	2100	4500	32	8.3	40.0
					KS702_0060MEL			38	12.0	41.0
8.000	250	400	600	4	KS702_0080ME	2500	5000	32	5.5	41.0
					KS702_0080MEL			38	9.2	
10.00	250	400	600	4	KS702_0100ME	2800	6000	32	4.4	41.0
					KS702_0100MEL			38	8.2	42.0
14.00	250	400	600	4	KS702_0140ME	3000	6000	32	3.4	42.0
					KS702_0140MEL			38	7.1	
20.00	250	400	600	4	KS702_0200ME	3200	6000	32	2.9	42.0
					KS702_0200MEL			38	6.7	
24.00	240	400	600	4	KS703_0240ME	3000	6000	24	1.6	42.0
					KS703_0240MEL			32	3.2	
32.00	250	400	600	4	KS703_0320ME	3000	6000	24	1.5	42.0
					KS703_0320MEL			32	3.1	
40.00	250	400	600	4	KS703_0400ME	3000	6000	24	1.4	42.0
					KS703_0400MEL			32	3.0	
50.00	250	400	600	4	KS703_0500ME	3200	6000	24	1.2	42.0
					KS703_0500MEL			32	2.8	
70.00	250	400	600	4	KS703_0700ME	3500	6000	24	1.0	42.0
					KS703_0700MEL			32	2.6	
80.00	250	400	600	4	KS703_0800ME	4000	6000	24	0.9	42.0
					KS703_0800MEL			32	2.6	
100.0	250	400	600	4	KS703_1000ME	4000	6000	24	0.9	42.0
					KS703_1000MEL			32	2.6	
140.0	250	400	600	4	KS703_1400ME	4000	6000	24	0.9	42.0
					KS703_1400MEL			32	2.5	
200.0	250	400	600	4	KS703_2000ME	4000	6000	24	0.9	42.0
					KS703_2000MEL			32	2.5	

KS Series: RIGHT ANGLE – Versatile Outputs

¹⁾ Based on input speed of 2000 RPM. See page 260 for details on torque calculations.

²⁾ Maximum momentary torque for emergency stops or heavy shock load. (Admissible stops per life of gearhead = 1,000 stops maximum.)

³⁾ Inertia based on maximum input. For lower inertia, using smaller diameter input, contact STÖBER.

* MT = Motor Adapter L = Large Input Option