



STÖBER

POSIDYN® SDS 5000

Projecting manual

Installation

Connecting

Accessories



V 5.6-N or later



03/2015

en

Table of contents

1	Introduction	6
1.1	Purpose of the manual	6
1.2	Further documentation	6
1.3	Further support	6
1.4	Abbreviations, formula symbols and indices	7
1.5	Symbols, identifiers, marks	9
2	Notes on safety	11
2.1	Component part of the product	11
2.2	Operation in accordance with its intended use	11
2.3	Risk assessment	11
2.4	Ambient conditions	12
2.5	Qualified personnel	12
2.6	Transportation and storage	13
2.7	Installation and connection	13
2.8	Commissioning, operation and service	14
2.9	Disposal	15
2.10	Residual dangers	15
2.11	UL-compliant use	15
2.12	Presentation of notes on safety	17
3	Technical data	18
3.1	General data of the inverters	18
3.1.1	Transportation, storage and operating environment	18
3.1.2	Device features	19
3.1.3	Weight	19
3.2	Electrical data of the inverters	20
3.2.1	Size 0 (BG 0): SDS 5007 to SDS 5015	20
3.2.2	Size 1 (BG 1): SDS 5040 to SDS 5075	22

3.2.3	Size 2 (BG 2): SDS 5110 and SDS 5150	23
3.2.4	Size 3 (BG 3): SDS 5220 to SDS 5450	24
3.2.5	Derating by increasing the switching frequency	25
3.3	Dimensions	26
3.3.1	Size 0 to 2: SDS 5007 to SDS 5150	26
3.3.2	Size 3: SDS 5220 to SDS 5450	28
3.4	Brake resistors SDS 5xxx	30
3.4.1	FZMU, FZZM	30
3.4.2	VHPR	32
3.4.3	FZZT, FZDT and FGFT	34
3.4.4	Bottom brake resistor RB 5000	36
3.5	Brake resistors SDS 5xxxA	37
3.5.1	FZMU, FZZMU	37
3.5.2	GVADU, GBADU	39
3.5.3	FGFKU	40
3.5.4	Bottom brake resistor RB 5000	42
3.6	Output derater	43
4	Installation	48
4.1	Installation of the inverter in the switching cabinet	48
4.2	Accessories	50
4.2.1	Installation of bottom brake resistor	50
4.2.2	Installation of EMC shroud or brake module	52
4.2.3	Installation of the terminal accessories	55
4.2.4	Installation of CANopen, PROFIBUS, EtherCAT or PROFINET accessories	58
5	Connection	63
5.1	Overview of terminals	63
5.2	EMC connection	67
5.3	X10: 230 V/400 V power	68
5.3.1	Line fuse	69

Table of contents

Projecting manual POSIDYN® SDS 5000



5.3.2	Residual current safety device	70
5.3.3	Housing ground	71
5.3.3.1	Size 0 to 2	71
5.3.3.2	Size 3	71
5.3.4	Forming	72
5.4	X11: 24 V power	74
5.5	X1: Enable and relay 1	76
5.6	X20: Motor	77
5.7	X12: ASP 5001 – Safe Torque Off	80
5.8	X2; X141: Motor temperature sensor	81
5.9	X5; X300 - X302: Motor holding brake	84
5.10	X21: Braking resistor	89
5.11	X22: DC link coupling	90
5.12	X100 - X103: Analog and binary signals	95
5.13	Encoder	102
5.13.1	X4	102
5.13.2	X120	106
5.13.3	X140	110
5.13.4	BE encoder and BA encoder simulation	113
5.14	Fieldbus	116
5.14.1	X200: CANopen	116
5.14.2	X200: PROFIBUS	117
5.14.3	X200, X201: EtherCAT	118
5.14.4	X200, X201: PROFINET	119
5.15	X3A, X3B: PC, IGB	120
5.16	Cables	121
5.16.1	Power cable	121
5.16.2	Encoder Cables	123
5.16.2.1	Encoder EnDat and SSI	123

Table of contents

Projecting manual POSIDYN® SDS 5000



5.16.2.2	Encoder EnDat Sin/Cos	126
5.16.2.3	Encoder HTL	129
5.16.2.4	Resolver	130
6	Examples of connections	133
7	Accessories	134

WE KEEP THINGS MOVING

1 Introduction

1.1 Purpose of the manual

This document will give you technical data and information about the installation and connection of the inverter and its accessories. This technical documentation will enable the following personnel to perform their tasks correctly.

- Project engineer - planning
- Electrical specialist - installation and connection

Original version

The original version of this manual is in German.

1.2 Further documentation

Manual	Contents	ID
Commissioning Instructions SDS 5000	Reinstallation, replacement, function test	442301
Operating manual SDS 5000	Set up the inverter	442289
Operating manual CANopen	Connection of the inverter to the CANopen fieldbus system	441686
Operating manual EtherCAT	Connection of the inverter to the EtherCAT fieldbus system	441896
Operating manual PROFIBUS	Connection of the inverter to the PROFIBUS fieldbus system	441687
Operating manual PROFINET	Connection of the inverter to the PROFINET fieldbus system	442340
Operating manual ASP 5001	Integration of the safety technology with the ASP 5001 option	442181

You can find the latest document versions at www.stoeber.de

1.3 Further support

If you have technical questions that are not answered by this document, please contact:

- Phone: +49 7231 582-3060
- E-mail: applications@stoeber.de

If you have questions about the documentation, please contact:

- E-mail: electronics@stoeber.de

If you have questions about training sessions, please contact:

- E-mail: training@stoeber.de



1.4 Abbreviations, formula symbols and indices



Abbreviations	
AA	Analog output
AC	Alternating Current
AE	Analog input
AES	Absolute Encoder Support
BA	Binary output
BAT	Battery
BE	Binary input
BG	Size
CAN	Controller Area Network
CH	Brake chopper
CNC	Computerized Numerical Control
CU	Control Unit
DC	Direct Current
I/O	Input/Output
EMC	Electromagnetic Compatibility
HTL	High threshold logic
IP	International Protection
PE	Protective Earth
PELV	Protective Extra Low Voltage
PTC	Positive Temperature Coefficient
PU	Power Unit
PWM	Pulse Width Modulation
RB	Brake Resistor
RCD	Residual Current Device
PLC	Programmable logic controller
SSI	Serial Synchronous Interface
TTL	Transistor-transistor logic
UL	Underwriters Laboratories
ZK	DC link

Formula symbols	Unit	Explanation
f	Hz	Frequency
f_2	Hz	Output frequency
f_{2PU}	Hz	Output frequency of the inverter power board
f_{max}	Hz	Maximum frequency
$f_{PWM,PU}$	Hz	Internal pulse clock frequency of the inverter power board
I	A	Current
I_1	A	Input current
I_{1maxPU}	A	Maximum input current of the inverter power board
I_{1maxCU}	A	Maximum input current of the inverter control board
$I_{1N,PU}$	A	Nominal input current of the inverter power board
I_2	A	Output current
I_{2max}	A	Maximum output current
I_{2maxPU}	A	Maximum output current of the inverter power board
I_{2min}	A	Minimum output current
$I_{2N,PU}$	A	Nominal output current of the inverter power board
I_N	A	Nominal current
n	rpm	Speed
n_N	rpm	Nominal speed: Speed at which the nominal torque M_N is reached.
P	W	Power
P_{2maxPU}	W	Maximum sum of drive power
P_{maxRB}	W	Maximum power at the external braking resistor
$P_{V,PU}$	W	Power loss of the inverter power board
$P_{V,CU}$	W	Power loss of the inverter control board
R	Ω	Resistance
R_{2minRB}	Ω	Minimum resistance of the external braking resistor
R_{int}	Ω	Internal resistance
R_{intRB}	Ω	Resistance of the internal braking resistor
ϑ	°C	Temperature
$ϑ_{amb,max}$	°C	Maximum surrounding temperature



Formula symbols	Unit	Explanation
T_{th}	s	Thermal time constant
t	s	Time
t_{min}	s	Minimum time
R	V	Voltage
U_1	V	Input voltage
U_{1PU}	V	Input voltage of the inverter power board
U_{1max}	V	Maximum input voltage
U_2	V	Output voltage
U_{2BAT}	V	Output voltage of the backup battery
U_{2PU}	V	Output voltage of the inverter power board
U_{max}	V	Maximum voltage
U_{maxPU}	V	Maximum voltage of the inverter power board
U_{offCH}	V	Off limit of the brake chopper
U_{onCH}	V	On limit of the brake chopper
		Other
p		Number of pole pairs

1.5 Symbols, identifiers, marks

Symbols	
	EN 61558-2-20 Choke without overload protection.
	Grounding symbol according to IEC 60417-5019 (DB:2002-10).

Identification and test symbols	
	Lead-free identifier for RoHS Lead-free identifier according to RoHS directive 2011-65-EU.
	CE mark Manufacturer's self declaration: The product meets the requirements of EU directives.

Identification and test symbols

	<p>UL test mark</p> <p>This product is listed by UL for the USA and Canada. Representative samples of this product have been evaluated by UL and meet the requirements of applicable standards.</p>
	<p>UL test marks for recognized component</p> <p>This component or material is recognized by UL. Representative samples of this product have been evaluated by UL and meet applicable requirements.</p>

POSIDRIVE, POSIDYN and POSISwitch are trademarks of STÖBER Antriebstechnik GmbH & Co. KG.

The following names that are used in conjunction with the device, its optional equipment and its accessories are trademarks or registered trademarks of other companies:

Trademarks	
CANopen, CiA	CANopen and CiA are registered Community trademarks of CAN in Automation e.V., Nuremberg, Germany.
EnDat	EnDat and the EnDat logo are registered trademarks of Dr. Johannes Heidenhain GmbH, Traunreut, Germany.
EtherCAT	EtherCAT and the EtherCAT logo are registered trademarks of Beckhoff Automation GmbH, Verl, Germany.
PROFIBUS, PROFINET	The PROFIBUS/PROFINET logo is a registered trademark of PROFIBUS Nutzerorganisation e. V. Karlsruhe, Germany.

All other trademarks that are not listed here are the property of their respective owners.

Products that are registered as trademarks are not specially indicated in this documentation. Existing property rights (patents, trademarks, protection of utility models) are to be observed.

2 Notes on safety

The devices can represent a source of danger. Therefore observe

- the safety guidelines, technical rules and regulations given in the following sections and the
- Generally applicable technical rules and regulations.

Always read the corresponding documentation as well. STÖBER ANTRIEBSTECHNIK GmbH & Co. KG shall assume no liability for damage resulting from failure to comply with the instruction manual or relevant regulations. This documentation is purely a production description. It does not include any guaranteed features in terms of a warranty right. We reserve the right to make technical changes for the purpose of improving the devices.

2.1 Component part of the product

The technical documentation is a component part of a product.

- Since the technical documentation contains important information, always keep it handy in the vicinity of the device until the machine is disposed of.
- If the product is sold, disposed of, or rented out, always include the technical documentation with the product.

2.2 Operation in accordance with its intended use

As defined by DIN EN 50178 (previously VDE 0160), the inverters are electrical equipment operating as power electronics to control the flow of energy in high voltage systems. They are designed exclusively for installation in the control cabinet with at least protection class IP54 and for supplying

- servo motors and
- asynchronous motors.

Designated use does not include connecting other electrical loads!

2.3 Risk assessment

Before the manufacturer may bring a machine onto the market, he must conduct a risk assessment according to Machine Directive 06/42/EC. As a result, the risks associated with the use of the machine are determined. The risk assessment is a multi-stage and iterative process. On no account can sufficient insight into the Machine Directive be given as part of this documentation. For this reason, seek detailed information about the norms and legal position. When installing the inverter in machines, commissioning is forbidden until it has been determined that the machine meets the requirements of EC Directive 06/42/EC.

2.4 Ambient conditions

The inverters are products subject to sales restrictions in accordance with IEC 61800-3. In a residential environment this product may cause high-frequency interference. If this occurs the user may be asked to take suitable measures to reduce it.

The inverters are not designed for use in a public low frequency network that supplies residential areas. High-frequency interference can be expected if the inverters are used in a network of this type. The inverters are designed exclusively for operation in TN networks. The inverters are only suitable for use in supply current networks that are able to provide a maximally symmetrical nominal short circuit current at maximally 480 volts according to the following table:

Size	Max. symmetrical nominal short-circuit current
0 and 1	5,000 A
2	5,000 A
3	10,000 A

Install the inverter in a control cabinet in which the admissible surrounding temperature will not be exceeded. The following applications are prohibited:

- Use in areas subject to explosion hazard
- Use in environments with harmful substances as specified by EN 60721, for example oils, acids, gases, vapors, dust and radiation
- Use with mechanical vibration and impact loads exceeding the limits specified in the technical data in the projecting manuals

Implementation of the following applications is only permitted after approval is obtained from STOBER:

- Use in non-stationary applications

2.5 Qualified personnel

Since the devices may harbor residual risks, all configuration, transportation, installation and commissioning tasks including operation and disposal may only be performed by trained personnel who are aware of the possible risks.

Personnel must have the qualifications required for the job. The following table lists examples of occupational qualifications for the jobs:

Activity	Possible occupational qualifications
Transportation and storage	Worker skilled in storage logistics or comparable training
Configuration	- Graduate engineer (electro-technology or electrical power technology) - Technician (m/f) (electro-technology)
Installation and connection	Electronics technician (m/f)

Activity	Possible occupational qualifications
Commissioning (of a standard application)	- Technician (m/f) (electro-technology) - Master electro technician (m/f)
Programming	Graduate engineer (electro-technology or electrical power technology)
Operation	- Technician (m/f) (electro-technology) - Master electro technician (m/f)
Disposal	Electronics technician (m/f)

In addition, the valid regulations, the legal requirements, the reference books, this technical documentation and, in particular, the safety information contained therein must be carefully

- read,
- understood and
- complied with.

2.6 Transportation and storage

Immediately upon receipt, examine the delivery for any transportation damages. Immediately inform the transportation company of any damages. If damages are found, do not commission the product. If the device is not to be installed immediately, store it in a dry, dust-free room. Please see the documentation for how to commission an inverter after it has been in storage for a year or longer.

2.7 Installation and connection

Installation and connection work are only permitted after the device has been isolated from the power! The accessory installation instructions allow the following actions during the installation of accessories:

- The housing in the upper slot can be opened
- The housing in the bottom slot can be opened.

Opening the housing in another place or for other purposes is not permitted.

Use only copper conductors. For the line cross sections to be used, refer to DIN VDE 0298-4 or DIN EN 60204-1 Appendix D and Appendix G.

The permissible protection class is protective ground. Operation is not permitted unless the protective ground is connected in accordance with the regulations.

Comply with the applicable instructions for installation and commissioning of motor and brakes.

Main equipment grounding markings: The main ground connections are marked "PE" or with the international ground symbol (IEC 60417, Symbol 5019 )

The motor must have an integrated temperature monitor with basic isolation in acc. with EN 61800-5-1 or external motor overload protection must be used.

Protect the device from falling parts (pieces of wire, leads, metal parts, and so on) during installation or other tasks in the switching cabinet. Parts with conductive properties inside the inverter can cause short circuits or device failure.

Note for UL-compliant use additionally 2.11.

2.8 Commissioning, operation and service

Remove the additional covers before commissioning so that the device will not overheat. Note the minimum open areas specified in the projecting manuals during installation to prevent the inverter from overheating.

The inverter housing must be closed before you turn on the power supply voltage. When the power supply voltage is turned on, hazardous voltages may be present on the connection terminals and the cables and motor terminals connected to them. Note that the device is not reliably free of voltage simply because all the displays are blank.

The following actions are prohibited while the supply voltage is applied

- Opening the housing,
- Connecting or disconnecting connection clamps and
- Installing accessories.

Apply the 5 safety rules in the order stated before performing any work on the machine:

1. Disconnect.
Also ensure that the auxiliary circuits are disconnected.
2. Protect against being turned on again.
3. Check that voltage is not present.
4. Ground and short circuit.
5. Cover adjacent live parts.



Information

Note that the discharge time of the DC link capacitors is up to 5 minutes. You can only determine the absence of voltage after this time period.

You can carry out work on the inverter later. Repairs may only be performed by STÖBER.

Send faulty devices with a fault description to:

STÖBER ANTRIEBSTECHNIK GmbH & Co. KG
Abteilung VS-EL
Kieselbronner Str.12
75177 Pforzheim
GERMANY

2.9 Disposal

Please comply with the latest national and regional regulations! Dispose of the individual parts separately depending on their nature and currently valid regulations such as, for example:

- Electronic scrap (PCBs)
- Plastic
- Sheet metal
- Copper
- Aluminum

2.10 Residual dangers

The connected motor can be damaged with certain settings of inverters:

- Longer operation against an applied motor halting brake
- Longer operation of self-cooled motors at slow speeds

Drives can reach dangerous excess speeds (e.g., setting of high output frequencies for motors and motor settings which are unsuitable for this). Secure the drive accordingly.

2.11 UL-compliant use

Additional information for use under UL conditions (UL – Underwriters Laboratories).

Surrounding temperature and pollution degree

The maximum surrounding temperature for UL-compliant operation is 45 °C.

Observe the specifications in the general data for use in an environment with a pollution degree, see section 3.1.1.

Power grid type

All device types that are supplied with 480 V are designed exclusively for operation on Wye sources with 480/277 V.

Power supply and motor overload protection

Observe the specifications in the electrical data of the inverter for this, see section 3.2.

Line fuse

Observe the specifications for the UL-compliant line fuse in section 5.3.1.

Motor protection

All models of STÖBER 5th generation inverters have a certified i²t model, a calculation model for thermal monitoring of the motor. This fulfills the requirements for semiconductor motor overload protection in accordance with the change to UL 508C dated May 2013. To activate the protective function and set it up,

make the following parameter settings – which differ from the default values: U10 = 2:Warning and U11 = 1.00 s. This model can be used as an alternative or in addition to motor protection with temperature monitoring as described in section 5.8.



Information

STÖBER ANTRIEBSTECHNIK GmbH & Co. KG recommends using PTC thermistors as thermal motor protection.

Motor temperature sensor

All models of the 5th generation of STÖBER inverters starting with HW 200 have connections for PTC thermistors (NAT 145 °C) or KTY temperature sensors (KT84-130). Observe the terminal description X2 for proper connection, see section 5.8.

Braking resistor

If the inverters will be fitted with an externally mounted braking resistor, separate overtemperature protection must be made available.

24 V power supply

Low-voltage circuits shall be supplied by an isolating source such that the maximum open circuit voltage available to the circuit is not more than 28.8 V.

Observe terminal description X11 for this, see section 5.4.

Lines

Use only copper conductors for an surrounding temperature of 60/75 °C.

Fuses

Use a 1 A fuse (time lag) upstream from relay 1. The fuse must be approved in accordance with UL 248.

Refer to the connection example of terminal description X1 for this, see section 5.5.

Branch circuit protection

An integral solid state short circuit protection does not provide branch circuit protection. If you would like to branch the output of the inverter, branch circuit protection must be ensured in conformity with the instructions of STÖBER, the National Electrical Code and all additional applicable local regulations or equivalent specifications.

UL test

During the UL acceptance process of STÖBER ANTRIEBSTECHNIK GmbH & Co. KG, only risks for electrical shock and fire hazard were investigated. Aspects of functional safety were not assessed. These aspects are assessed for STÖBER by the TÜV SÜD certification authority, for example.

2.12 Presentation of notes on safety

NOTICE

Notice

means that property damage may occur

- ▶ if the stated precautionary measures are not taken.
-

CAUTION!

Caution

with warning triangle means that minor injury may occur

- ▶ if the stated precautionary measures are not taken.
-

WARNING!

Warning

means that there may be a serious danger of death

- ▶ if the stated precautionary measures are not taken.
-

DANGER!

Danger

means that serious danger of death exists

- ▶ if the stated precautionary measures are not taken.
-



Information

refers to important information about the product or serves to emphasize a section in the documentation to which the reader should pay special attention.

3 Technical data

Product key

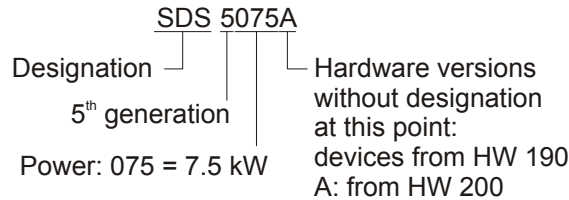

Please note:

Unless an explicit difference is noted between the hardware variants in the technical data, the information applies to both hardware versions.

3.1 General data of the inverters

3.1.1 Transportation, storage and operating environment

NOTICE

Material damage!

The DC link capacitors in devices of sizes 0, 1 and 2 can lose their electrical strength through long storage times. Considerable material damage can arise from a reduced electrical strength of the DC link capacitors when switching on.

- ▶ Use devices in storage annually or before startup.

Maximum surrounding air temperature during operation	0° C to 45° C for rated data Up to 55° C with power reduction, 2.5 %/K
Temperature during storage/transportation	-20° C to +70° C Maximum change: 20 K/h
Humidity	Relative humidity: 85 %, no condensation
Installation altitude	Up to 1000 m above sea level without restrictions 1000 to 2000 m above sea level with power reduction, 1.5 %/100 m
Pollution degree	2 as per EN 50178
Ventilation	Built-in fan
Vibration (operation) acc. to DIN EN 60068-2-6	5 Hz ≤ f ≤ 9 Hz: 0.35 mm 9 Hz ≤ f ≤ 200 Hz: 1 m/s
Vibration (transportation) acc. to DIN EN 60068-2-6	5 Hz ≤ f ≤ 9 Hz: 3.5 mm 9 Hz ≤ f ≤ 200 Hz: 10 m/s 200 Hz ≤ f ≤ 500 Hz: 15 m/s



3.1.2 Device features

Protection rating	IP20
Interference suppression	EN 61800-3, interference emission, class C3
High-voltage category	III as per EN 61800-5-1

3.1.3 Weight

Device	Weight	
	Without Packaging [kg]	With Packaging [kg]
SDS 5007	2.3	3.5
SDS 5008		
SDS 5015		
SDS 5040	3.9	5.3
SDS 5075		
SDS 5110	5.0	6.2
SDS 5150		
SDS 5220	11.9	13.7
SDS 5370	13.3	15.1
SDS 5450		

If you order an inverter with accessory parts, the weight increases by the following amounts:

- Accessory parts for higher option (fieldbus): 0.1 kg
- Accessory parts for lower option (terminals): 0.2 kg

3.2 Electrical data of the inverters



Information

An explanation of the most important formula symbols can be found in section 1.4 Abbreviations, formula symbols and indices.

3.2.1 Size 0 (BG 0): SDS 5007 to SDS 5015

Device	SDS 5007	SDS 5008	SDS 5015
ID no. up to HW 190 (SDS 5xxx) start. from HW 200 (SDS 5xxxA)	49825 55428	49826 55429	49827 55430
Recommended motor power	0.75 kW	0.75 kW	1.5 kW
U_{1PU}	(L1 – N) 1 × 230 V +20 % / -40 % 50/60 Hz	(L1 – L3) 3 × 400 V, +32 % / -50 %, 50 Hz (L1 – L3) 3 × 480 V, +10 % / -58 %, 60 Hz	
$I_{1N,PU}$	1 × 5.9A	3 × 2 A	3 × 3.7
f_{2PU}	ID 49825, 49826, 49827: 0 to 400 Hz ID 55428, 55429, 55430: 0 to 700 Hz		
U_{2PU}	0 to 230 V	0 to 400 V	

Operation with servo motor (control type servo)

$I_{2N,PU}$	ID 49825: 3 × 3 A ID 55428: 3 × 3 A	ID 49826: 3 × 1.5 A ID 55429: 3 × 1.7 A	ID 49827: 3 × 3 A ID 55430: 3 × 3.4 A
I_{2maxPU}	250 % for 2 s; 200 % for 5 s		
$f_{PWM,PU}$	8 kHz (adjustable up to 16 kHz, see chap. 3.2.5 Derating by increasing the switching frequency)		

Operation with asynchronous motor (control types U/f, SLVC, VC)

$I_{2N,PU}$	ID 49825: 3 × 4 A ID 55428: 3 × 4 A	ID 49826: 3 × 2.1 A ID 55429: 3 × 2.3 A	ID 49827: 3 × 4 A ID 55430: 3 × 4.5 A
I_{2maxPU}	180 % for 5 s; 150 % for 30 s		
$f_{PWM,PU}$	4 kHz (adjustable up to 16 kHz, see chap. 3.2.5 Derating by increasing the switching frequency)		



$P_{V,PU} (I_2 = I_N)$	80 W	65 W	90 W
$P_{V,CU} (I_2 = 0 A)^{a)}$	Max. 30 W		
U_{maxPU}	440 V	830 V	
U_{onCH}	400 V to 420 V	780 V to 800 V	
U_{offCH}	360 V to 380 V	740 V to 760 V	
R_{2minRB}	100 Ω	100 Ω	
P_{maxRB}	1,8 kW	6,4 kW	

a) Depends on the connected option boards and sensors (e.g., encoder)

3.2.2 Size 1 (BG 1): SDS 5040 to SDS 5075

Device	SDS 5040	SDS 5075
ID no. up to HW 190 (SDS 5xxx) start. from HW 200 (SDS 5xxxA)	49829 55431	49830 55432
Recommended motor power	4.0 kW	7.5 kW
U_{1PU}	(L1 – L3) 3 × 400 V, +32 % / -50 %, 50 Hz (L1 – L3) 3 × 480 V, +10 % / -58 %, 60 Hz	
$I_{1N,PU}$	3 × 9.3 A	3 × 15.8 A
f_{2PU}	ID 49829, 49830: 0 to 400 Hz ID 55431, 55432: 0 to 700 Hz	
U_{2PU}	0 to 400 V	

Operation with servo motor (control type servo)

$I_{2N,PU}$	3 × 6 A	3 × 10 A
I_{2maxPU}	250 % for 2 s; 200 % for 5 s	
$f_{PWM,PU}$	8 kHz (adjustable up to 16 kHz, see chap. 3.2.5 Derating by increasing the switching frequency)	

Operation with asynchronous motor (control types U/f, SLVC, VC)

$I_{2N,PU}$	3 × 10 A	3 × 16 A
I_{2maxPU}	180 % for 5 s; 150 % for 30 s	
$f_{PWM,PU}$	4 kHz (adjustable up to 16 kHz, see chap. 3.2.5 Derating by increasing the switching frequency)	

$P_{V,PU}$ ($I_2 = I_N$)	170 W	200 W
$P_{V,CU}$ ($I_2 = 0 A$) ^{a)}	Max. 30 W	
U_{maxPU}	830 V	
U_{onCH}	780 V to 800 V	
U_{offCH}	740 V to 760 V	
R_{2minRB}	ID 49829: 100 Ω ID 55431: 47 Ω	47 Ω
P_{maxRB}	ID 49829: 6.4 kW ID 55431: 13.6 kW	13.6 kW

a) Depends on the connected option boards and sensors (e.g., encoder).



3.2.3 Size 2 (BG 2): SDS 5110 and SDS 5150

Device	SDS 5110	SDS 5150
ID no. up to HW 190 (SDS 5xxx) start. from HW 200 (SDS 5xxxA)	49831 55433	49832 55434
Recommended motor power	11 kW	15 kW
U_{1PU}	(L1 – L3) 3 × 400 V, +32 % / -50 %, 50 Hz (L1 – L3) 3 × 480 V, +10 % / -58 %, 60 Hz	
$I_{1N,PU}$	3 × 24.5 A	3 × 32.6 A
f_{2PU}	ID 49831, 49832: 0 to 400 Hz ID 55433, 55434: 0 to 700 Hz	
U_{2PU}	0 to 400 V	

Operation with servo motor (control type servo)

$I_{2N,PU}$	3 × 14 A	3 × 20 A
I_{2maxPU}	250 % for 2 s; 200 % for 5 s	
$f_{PWM,PU}$	8 kHz (adjustable up to 16 kHz, see chap. 3.2.5 Derating by increasing the switching frequency)	

Operation with asynchronous motor (control types U/f, SLVC, VC)

$I_{2N,PU}$	3 × 22 A	3 × 32 A
I_{2maxPU}	180 % for 5 s; 150 % for 30 s	
$f_{PWM,PU}$	4 kHz (adjustable up to 16 kHz, see chap. 3.2.5 Derating by increasing the switching frequency)	

$P_{V,PU} (I_2 = I_N)$	220 W	280 W
$P_{V,CU} (I_2 = 0 A)^a)$	Max. 30 W	
U_{maxPU}	830 V	
U_{onCH}	780 V to 800 V	
U_{offCH}	740 V to 760 V	
R_{2minRB}	22 Ω	
P_{maxRB}	29.1 kW	

a) Depends on the connected option boards and sensors (e.g., encoder).

3.2.4 Size 3 (BG 3): SDS 5220 to SDS 5450

Device	SDS 5220	SDS 5370	SDS 5450
ID no. up to HW 190 (SDS 5xxx) from HW 200 (SDS 5xxxA)	49833 55435	49835 55436	49836 55437
Recommended motor rating	22 kW	37 kW	45 kW
U_{1PU}	(L1 – L3) 3 × 400 V, +32 % / -50 %, 50 Hz (L1 – L3) 3 × 480 V, +10 % / -58 %, 60 Hz		
$I_{1N,PU}$	3 × 37 A	3 × 62 A	3 × 76 A
f_{2PU}	ID 49833, 49835, 49836: 0 to 400 Hz ID 55435, 55436, 55437: 0 to 700 Hz		
U_{2PU}	0 to 400 V		

Operation with servo motor (control mode Servo)

$I_{2N,PU}$	3 × 30 A	3 × 50 A	3 × 60 A
I_{2maxPU}	250 % for 2 s; 200 % for 5 s		
$f_{PWM,PU}$	8 kHz (adjustable up to 16 kHz with derating, see section 3.2.5 Derating by increasing the switching frequency)		

Operation with asynchronous motor (control modes V/f, SLVC, VC)

$I_{2N,PU}$	3 × 44 A	3 × 70 A	3 × 85 A
I_{2maxPU}	180 % for 5 s; 150 % for 30 s		
$f_{PWM,PU}$	4 kHz (adjustable up to 16 kHz, see section 3.2.5 Derating by increasing the switching frequency)		

$P_{V,PU}$ ($I_2 = I_N$)	About 350 W	About 600 W	About 1000 W
$P_{V,CU}$ ($I_2 = 0 A$) ^{a)}	Max. 55 W		
U_{maxPU}	830 V		
U_{onCH}	780 V to 800 V		
U_{offCH}	740 V to 760 V		
R_{intRB}	30 Ω (PTC resistance; 100 W; max. 1 kW for 1 s; $\tau = 40$ s)		
R_{2minRB}	15 Ω		
P_{maxRB}	42 kW		

a) Depends on the connected option boards and sensors (encoder, etc.).



3.2.5 Derating by increasing the switching frequency

Based on the switching frequency $f_{PWM,PU}$ (Parameter *B24*), the following values of the output currents $I_{2N,PU}$ result. Remember that only 8 kHz and 16 kHz can be set for control type servo.

Output current $I_{2N,PU}$

Switching frequency	4 kHz	8 kHz	16 kHz
SDS 5007	4.0 A	3.0 A	2.0 A
SDS 5008			
– ID 49826:	2.1 A	1.5 A	1.1 A
– ID 55429:	2.3 A	1.7 A	1.2 A
SDS 5015			
– ID 49827:	4.0 A	3.0 A	2.0 A
– ID 55430:	4.5 A	3.4 A	2.2 A
SDS 5040	10.0 A	6.0 A	3.3 A
SDS 5075	16.0 A	10.0 A	5.7 A
SDS 5110	22.0 A	14.0 A	8.1 A
SDS 5150	32.0 A	20.0 A	11.4 A
SDS 5220	44.0 A	30.0 A	18.3 A
SDS 5370	70.0 A	50.0 A	31.8 A
SDS 5450	85.0 A	60.0 A	37.8 A

3.3 Dimensions

3.3.1 Size 0 to 2: SDS 5007 to SDS 5150

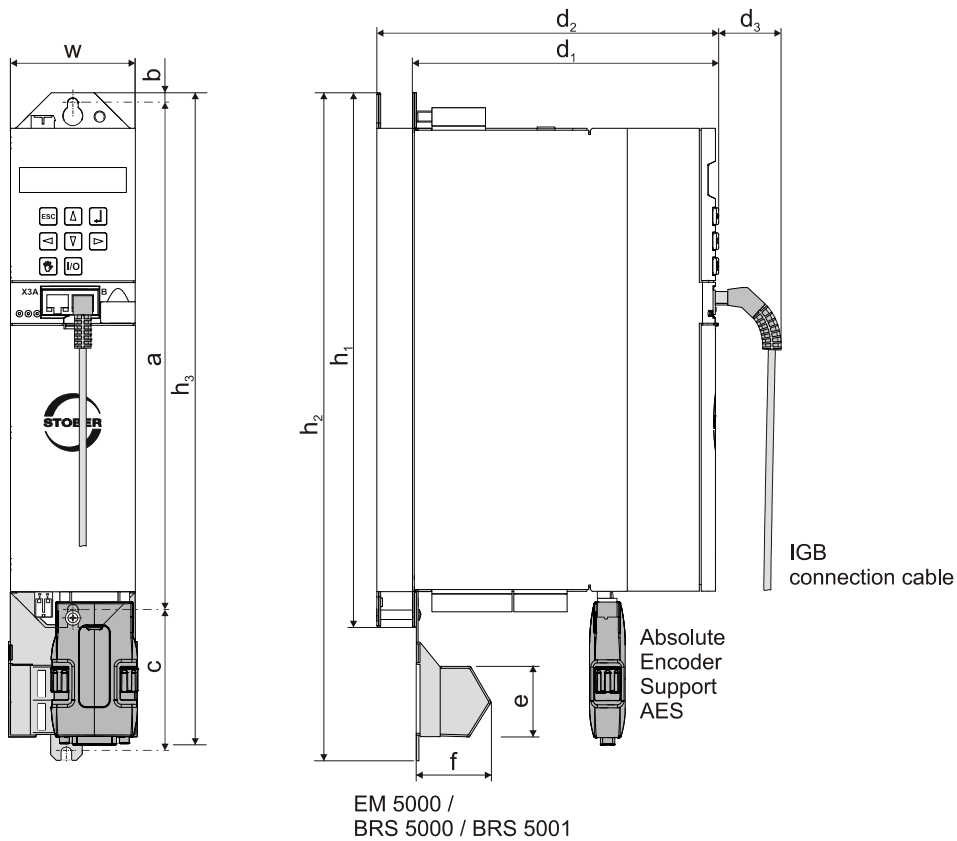

Dimensions [mm]			Size 0	Size 1	Size 2
Inverter	Height	h_1	300		
		h_2	360 ^{a)} / 373 ^{b)}		
		h_3 ^{c)}	365		
	Width	w	70		105
	Depth	d_1	175	260	260
		d_2 ^{d)}	193	278	278
d_3		40			
EMC shroud	Height	e	37.5 ^{e)} / 44 ^{f)}		
	Depth	f	40		
Fastening holes	Vertical distance to upper edge	b	6		
	Vertical distance	a	283+2		
	Vertical distance	c ^{g)}	79		

a) h_2 = Height incl. EMC shroud EM 5000 or brake module BRS 5000

b) h_2 = Height incl. brake module BRS 5001

c) h_3 = Height incl. AES

d) d_2 = Depth incl. brake resistor RB 5000

e) e = Height of the EMC shroud EM 5000 or brake module BRS 5000

f) e = Height of the brake module BRS 5001

g) c = Vertical distance at brake module BRS 5001



Information

Brake module BRS 5000 has been replaced by the follow-up model BRS 5001 (from firmware V 5.6-N). You can find more information about both models in section 7. Differences with regard to assembly and connection are described in the relevant section.

3.3.2 Size 3: SDS 5220 to SDS 5450

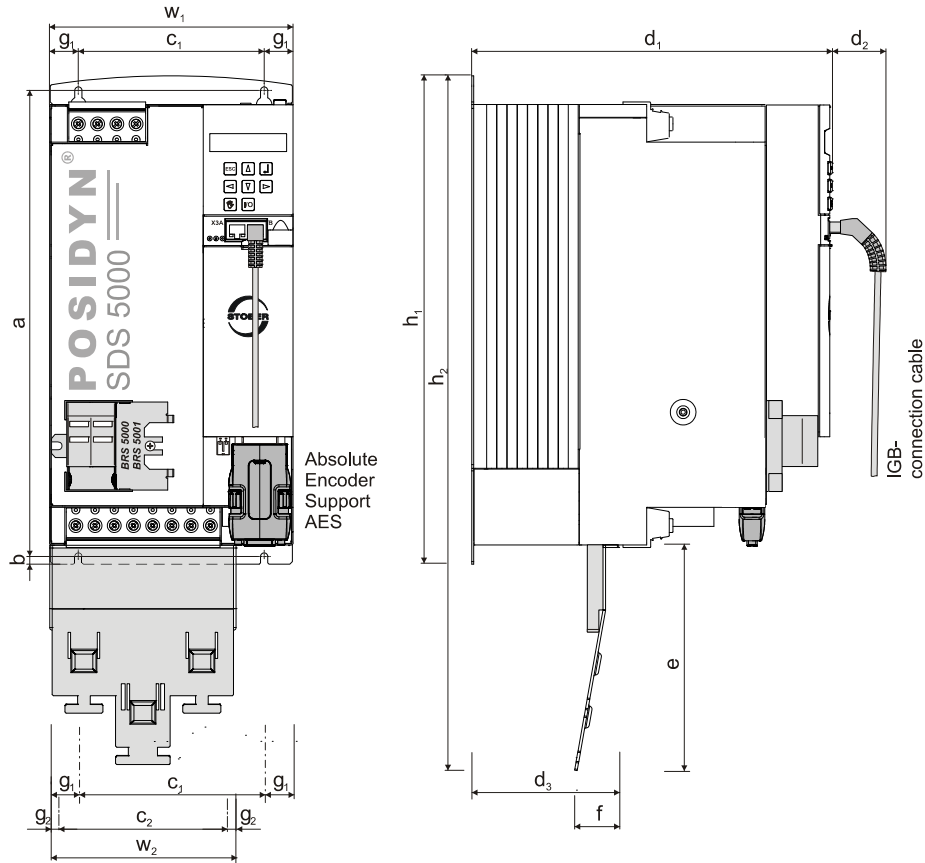



Dimensions [mm]		Size 3	
Inverter	Height	h_1	382.5
		h_2 ^{a)}	540
	Width	w_1	190
	Depth	d_1	276
		d_2	40
EMC shroud	Höhe	e	174
	Width	w_2	147
	Depth	f	34
	Depth	d_3	113
Fastening holes	Vertical distance	a	365+2
	Vertical distance to bottom edge	b	6
	Horizontal distance	c_1 ^{b)}	150+0.2/-0.2
	Horizontal distance from the side edge	g_1 ^{c)}	20
	Horizontal distance	c_2 ^{d)}	132
	Horizontal distance from the side edge	g_2 ^{e)}	7.5

a) h_2 = Height incl. EMC shroud EM6A3

b) c_1 = Horizontal distance from the fastening holes of the inverter

c) g_1 = Horizontal distance from the side edge of the inverter

d) c_2 = Horizontal distance from the fastening holes of the EMC shroud EM6A3

e) g_2 = Horizontal distance from the side edge of the EMC shroud EM6A3

3.4 Brake resistors SDS 5xxx

3.4.1 FZMU, FZZM

Braking resistor – inverter assignment



Type	FZMU 400x65		FZZM 400x65	FZZMU 400x65
	49010	49011	41642	41650
SDS 5007	X	—	—	—
SDS 5008	X	—	—	—
SDS 5015	X	—	—	—
SDS 5040	X	—	—	—
SDS 5075	X	—	—	—
SDS 5110	—	X	X	—
SDS 5150	—	X	X	—
SDS 5220	—	X	—	X
SDS 5370	—	X	—	X
SDS 5450	—	X	—	X

The internal connections are wired with heat-resistant, silicon-insulated strands of wire on terminals. Also ensure a heat-resistant and stress-resistance design for the connection!

Conductor cross-section

Connection type	Conductor cross-section [mm ²]
Rigid	0.5 – 4.0
Flexible with cable end sleeve	0.5 – 2.5

Properties

Type	FZMU 400x65		FZZM 400x65	FZZMU 400x65
	49010	49011	41642	41650
Resistance [Ω]	100	30	30	20
Power [W]	600		1200	
Therm. time const. τ_{th} [s]	40		40	
Pulse power for < 1 s [kW]	18		36	
Weight [kg]	Approx. 2.2		Approx. 4.2	
Protection class	IP20		IP20	
Test marks			—	



Dimensions [mm]

Type ID no.	FZMU 400x65		FZZM(U) 400x65	
	49010	49011	41642	41650
L x D	400 × 65		400 × 65	
H	120		120	
K	6.5 × 12		6.5 × 12	
M	430		426	
O	485		450	
R	92		185	
R	64		150	
X	10		10	

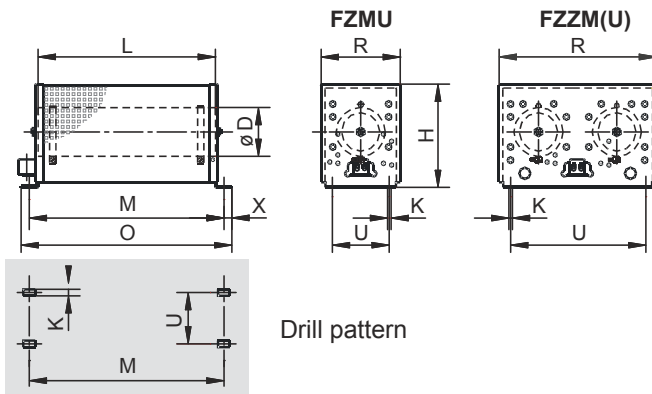



3.4.2 VHPR

Braking resistor – inverter assignment

Type ID no.	VHPR	
	45973	45974
SDS 5007	X	—
SDS 5008	X	—
SDS 5015	X	—
SDS 5040	X	—
SDS 5075	X	X
SDS 5110	—	X
SDS 5150	—	X
SDS 5220	—	X
SDS 5370	—	X
SDS 5450	—	X

Properties

Type ID no.	VHPR150V	VHPR500V
	45973	45974
Resistance [Ω]	100	47
Power [W]	150	400
Therm. time const. τ_{th} [s]	80	65
Pulse power for < 1 s [kW]	13	19.5
Weight [g]	Approx. 310	Approx. 1020
Protection class	IP54	IP54
Test marks		



Dimensions [mm]

Type	VHPR150V	VHPR500V
ID no.	45973	45974
L	212	337
C	193 ± 2	317 ± 2
B	40	60
A	21	31
D	4.3	5.3
E	8	11.5
F	13	19.5

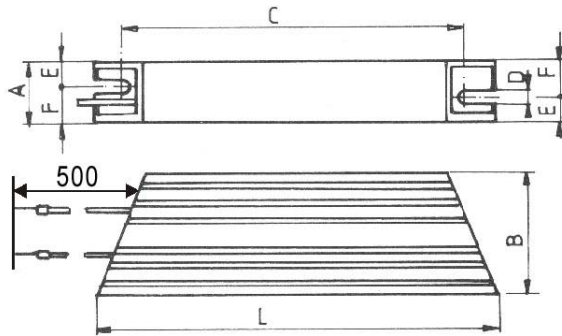

3.4.3 FZZT, FZDT and FGFT

Braking resistor – inverter assignment

Type	FZZT 400×65	FZDT 500×65	FGFT 3111202
ID no.	41651	41653	41655
SDS 5220	X	X	X
SDS 5370	X	X	X
SDS 5450	X	X	X

Properties

Type	FZZT 400×65	FZDT 500×65	FGFT 3111202
ID no.	41651	41653	41655
Resistance [Ω]	20	20	20
Power [W]	1200	2500	6000
Thermal time constant τ_{th}	30	30	20
Weight [kg]	Approx. 4.6	Approx. 7.8	Approx. 13
Protection class	IP20	IP20	IP20

Dimensions [mm]

Type	FZZT 400×65	FZDT 500×65
ID no.	41651	41653
L × D	400 × 65	500 × 65
H	120	120
K	6.5 × 12	6.5 × 12
M	426	526
O	506	606
R	185	275
R	150	240

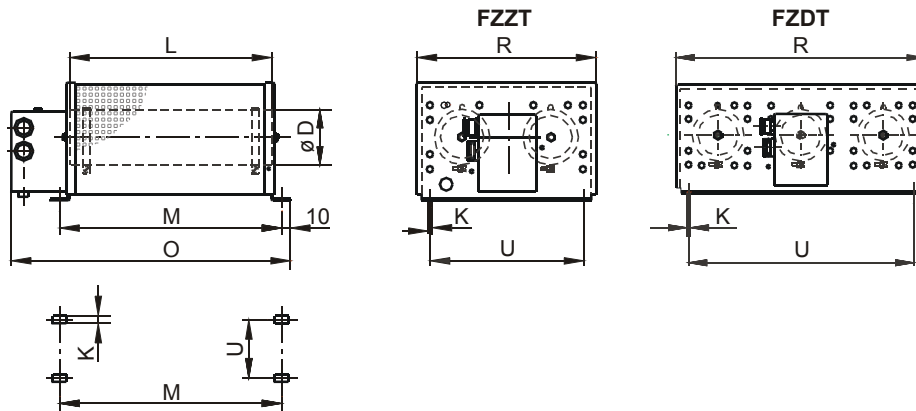

Dimensions [mm]

Type	FGFT 311202
ID no.	41655
A	370
B	395
C	455

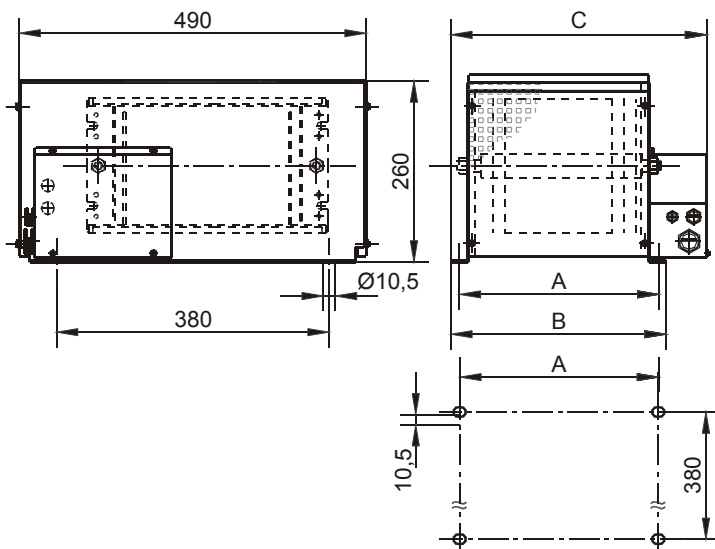

3.4.4 Bottom brake resistor RB 5000

Braking resistor – inverter assignment

Type	RB 5022	RB 5047	RB 5100
ID no.	45618	44966	44965
SDS 5008	—	—	X
SDS 5015	—	—	X
SDS 5040	—	—	X
SDS 5075	—	X	—
SDS 5110	X	—	—
SDS 5150	X	—	—

Note the attachment to the inverter (section 4 Installation)!

Properties

Type	RB 5022	RB 5047	RB 5100
ID no.	45618	44966	44965
Resistance [Ω]	22	47	100
Power [W]	100	60	60
Therm. time const. τ_{th} [s]	8		
Pulse power for < 1 s [kW]	1.5	1.0	1.0
U_{max} [V]	800		
Weight [g]	Approx. 640	Approx. 460	Approx. 440
Cable design	Radox		
Cable length [mm]	250		
Cable cross-section [AWG]	18/19 (0.82 mm ²)		
Maximum torque for studs [Nm]	5		
Protection class	IP40		
Test marks			

Dimensions [mm]

Type	RB 5022	RB 5047	RB 5100
ID no.	45618	44966	44965
Height	300	300	
Width	94	62	
Depth	18	18	
Drilling pattern corresponds to size	2	1	0 and 1



3.5 Brake resistors SDS 5xxxA

3.5.1 FZMU, FZZMU

Braking resistor – inverter assignment



Type ID no.	FZMU 400x65			FZZMU 400x65		
	49010	55445	55446	53895	55447	55448
SDS 5007A	X	—	—	—	—	—
SDS 5008A	X	—	—	—	—	—
SDS 5015A	X	—	—	—	—	—
SDS 5040A	—	—	—	X	—	—
SDS 5075A	—	—	—	X	—	—
SDS 5110A	—	X	—	—	X	—
SDS 5150A	—	X	—	—	X	—
SDS 5220A	—	—	X	—	—	X
SDS 5370A	—	—	X	—	—	X
SDS 5450A	—	—	X	—	—	X

The internal connections are wired with heat-resistant, silicon-insulated strands of wire on terminals. Also ensure a heat-resistant and stress-resistance design for the connection!

Conductor cross-section

Connection type	Conductor cross-section [mm ²]
Rigid	0.5 – 4.0
Flexible with cable end sleeve	0.5 – 2.5

Properties

Type ID no.	FZMU 400x65			FZZMU 400x65		
	49010	55445	55446	53895	55447	55448
Resistance [Ω]	100	22	15	47	22	15
Power [W]	600			1200		
Therm. time const. τ_{th} [s]	40			40		
Pulse power for < 1 s [kW]	18			36		
U_{max} [V]	848			848		
Weight [kg]	Approx. 2.2			Approx. 4.2		
Protection class	IP20			IP20		
Test marks						

Dimensions [mm]

Type ID no.	FZMU 400x65			FZZMU 400x65		
	49010	55445	55446	53895	55447	55448
L x D	400 × 65			400 × 65		
H	120			120		
K	6.5 × 12			6.5 × 12		
M	430			426		
O	485			450		
R	92			185		
R	64			150		
X	10			10		

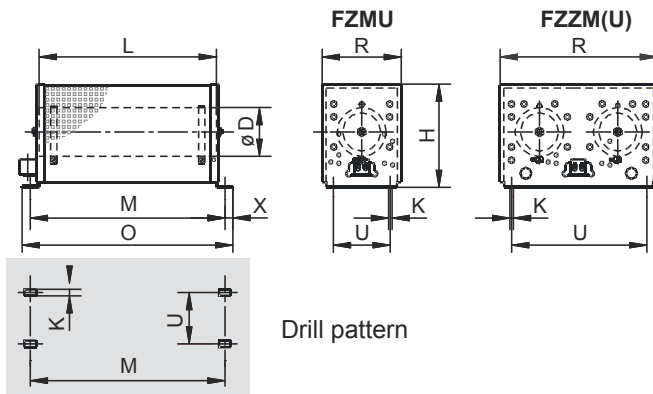



3.5.2 GVADU, GBADU

Braking resistor – inverter assignment

Type	GVADU 210x20	GBADU 265x30	GBADU 405x30	GBADU 335x30	GBADU 265x30
ID no.	55441	55442	55499	55443	55444
SDS 5007A	X	X	X	—	—
SDS 5008A	X	X	X	—	—
SDS 5015A	X	X	X	—	—
SDS 5040A	X	X	X	X	—
SDS 5075A	—	—	—	X	—
SDS 5110A	—	—	—	—	X
SDS 5150A	—	—	—	—	X
SDS 5220A	—	—	—	—	X
SDS 5370A	—	—	—	—	X
SDS 5450A	—	—	—	—	X

Properties

Type	GVADU 210x20	GBADU 265x30		GBADU 335x30	GBADU 405x30
ID no.	55441	55442	55444	55443	55499
Resistance [Ω]	100	100	22	47	100
Power [W]	150	300	300	400	500
Therm. time const. τ_{th} [s]	60	60			
Pulse power for < 1 s [kW]	3.3	6.6	6.6	8.8	11
U_{max} [V]	848	848			
Cable design	Radox	FEP			
Cable length [mm]	50	50			
Cable cross- section [AWG]	18/19 (0.82 mm ²)	14/19 (1.9 mm ²)			
Weight [g]	300	950	950	1200	1450
Protection class	IP54	IP54			
Test marks					

Dimensions [mm]

Type	GVADU 210×20	GBADU 265×30	GBADU 335×30	GBADU 405×30	
ID no.	55441	55442	55444	55443	55449
A	210	265	335	405	
H	192	246	316	386	
C	20	30	30	30	
D	40	60	60	60	
E	18.2	28.8	28.8	28.8	
F	6.2	10.8	10.8	10.8	
G	2	3	3	3	
K	2.5	4	4	4	
J	4.3	5.3	5.3	5.3	
β	65°	73°	73°	73°	

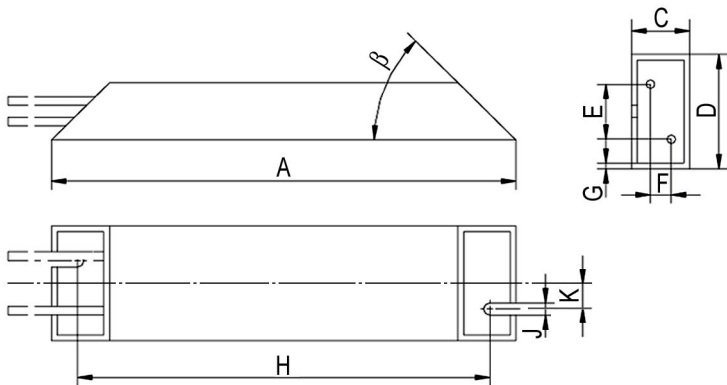



3.5.3 FGFKU

Braking resistor – inverter assignment

Type	FGFKU			
ID no.	55449	55450	55451	53897
SDS 5110A	X	—	—	—
SDS 5150A	X	—	—	—
SDS 5220A	—	X	X	X
SDS 5370A	—	X	X	X
SDS 5450A	—	X	X	X



Properties

Type	FGFKU			
ID no.	55449	55450	55451	53897
Resistance [Ω]	22	15	15	15
Power [W]	2500		6000	8000
Therm. time const. τ_{th} [s]	30		20	20
Pulse power for < 1 s [kW]	50		120	160
U_{max} [V]	848		848	848
Weight [kg]	Approx. 7.5		12	18
Test marks	C 		C 	C 

Dimensions [mm]

Type	FGFKU		
ID no.	55449 55450	55451	53897
A	270	370	570
B	295	395	595
C	355	455	655

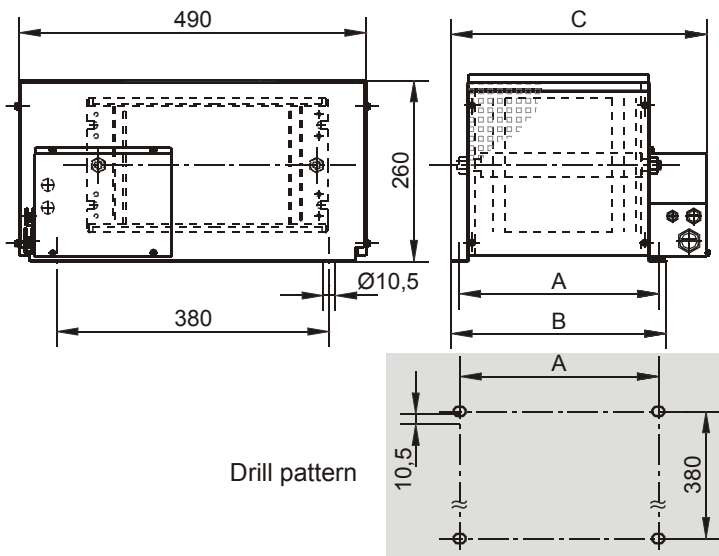

3.5.4 Bottom brake resistor RB 5000

Braking resistor – inverter assignment

Type	RB 5022	RB 5047	RB 5100
ID no.	45618	44966	44965
SDS 5008A	—	—	X
SDS 5015A	—	—	X
SDS 5040A	—	X	X
SDS 5075A	—	X	—
SDS 5110A	X	—	—
SDS 5150A	X	—	—

Note the attachment to the inverter (section 4 Installation)!

Properties

Type	RB 5022	RB 5047	RB 5100
ID no.	45618	44966	44965
Resistance [Ω]	22	47	100
Power [W]	100	60	60
Therm. time const. τ_{th} [s]	8		
Pulse power for < 1 s [kW]	1.5	1.0	1.0
U_{max} [V]	800		
Weight [g]	Approx. 640	Approx. 460	Approx. 440
Cable design	Radox		
Cable length [mm]	250		
Cable cross-section [AWG]	18/19 (0.82 mm ²)		
Maximum torque for studs [Nm]	5		
Protection class	IP40		
Test marks			

Dimensions [mm]

Type	RB 5022	RB 5047	RB 5100
ID no.	45618	44966	44965
Height	300	300	
Width	94	62	
Depth	18	18	
Drilling pattern corresponds to size	2	1	0 and 1

3.6 Output derater

WARNING!

Risk of burns! Fire hazard! Material damage!

Chokes can heat up to over 100°C under permitted operating conditions.

- ▶ Take protective measures against accidental and intentional contact with the choke.
- ▶ Make sure that no flammable material is in the vicinity of the choke.
- ▶ Do not install chokes under or near the inverter.

WARNING!

Fire hazard!

Using chokes outside of the nominal data (cable length, current, frequency, etc.) can cause the chokes to overheat.

- ▶ Always comply with the maximum nominal data when operating the chokes.

NOTICE

Danger of machine standstill!

The motor temperature sensor evaluation is malfunctioning due to cable capacities.

- ▶ If you use cables which are longer than 50 m and the cables are not from STÖBER, the cores for the motor temperature sensor and the brake must be separate (maximum length: 100 m).



Information

The following technical data applies for a rotary field frequency of 200 Hz. For example, this rotary field frequency is achieved with a motor with 4 pole pairs and a nominal speed of 3000 rpm.

Always observe the specified derating for higher rotary field frequencies.

Also observe the dependency of the cycle frequency.

Type	TEP3720-0ES41	4EP3820-0CS41	4EP4020-0RS41
ID no.	53188	53189	53190
Voltage range	3 x 0 to 480 V		
Frequency range	0 to 200 Hz		
I _N at 4 kHz	4 A	17.5 A	38 A
I _N at 8 kHz	3.3 A	15.2 A	30.4 A
Max. permitted motor cable length with output derater	100 m		
Max. surrounding temperature $\vartheta_{amb,max}$	40° C		
Design	Open		
Winding losses	11 W	29 W	61 W
Iron losses	25 W	16 W	33 W
Connections	Screw terminals		
Max. conductor cross-section	10 mm ²		
UL Recognized Component (CAN; USA)	Yes		
Test marks			

Projecting

Select the output chokes according to the rated currents of the motor and output chokes. In particular, observe the derating of the output choke for rotary field frequencies higher than 200 Hz.

You can calculate the rotary field frequency for your drive with the following formula:

$$f = n_N \cdot \frac{p}{60}$$

f Rotary field frequency in Hz

n Speed in rpm

p Number of pole pairs

N Nominal value



Derating TEP3720-0ES41

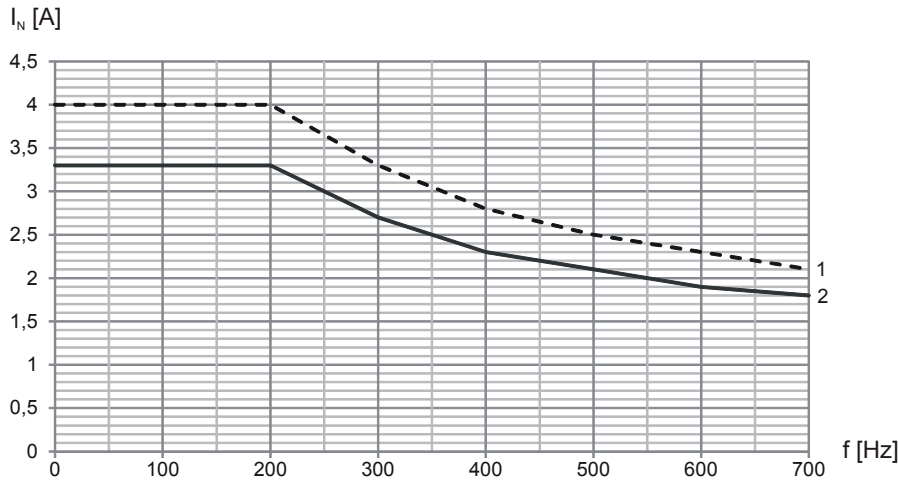

- 1 Cycle frequency 4 kHz
- 2 Cycle frequency 8 kHz

Derating 4EP3820-0CS41

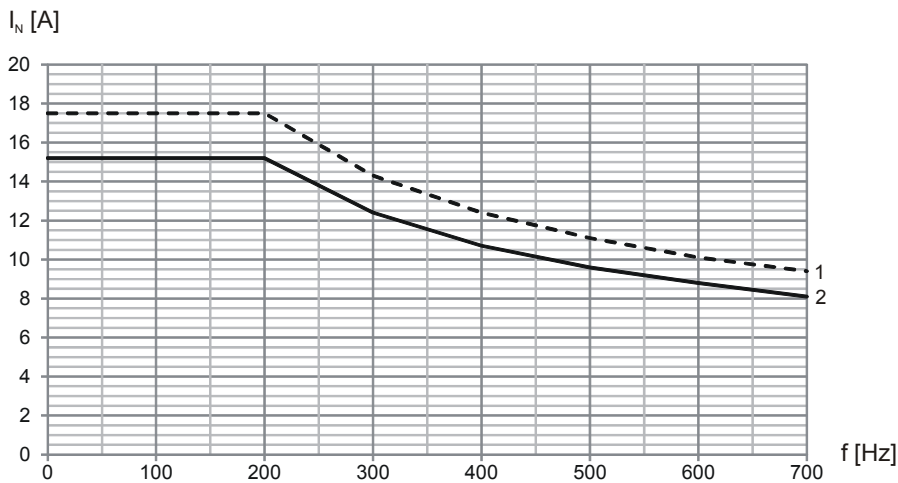

- 1 Cycle frequency 4 kHz
- 2 Cycle frequency 8 kHz

Derating 4EP4020-0RS41

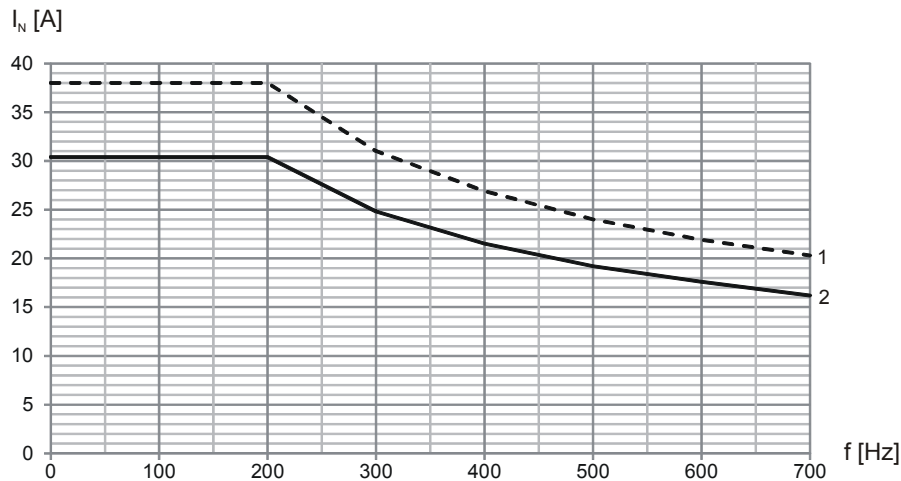

- 1 Cycle frequency 4 kHz
- 2 Cycle frequency 8 kHz

Dimensions	TEP3720-0ES41	4EP3820-0CS41	4EP4020-0RS41
Height h [mm]	Max. 153	Max. 153	Max. 180
Width w [mm]	178	178	219
Depth d [mm]	73	88	119
Vertical distance – fastening holes a1 [mm]	166	166	201
Vertical distance – fastening holes a2 [mm]	113	113	136
Horizontal distance – fastening holes b1 [mm]	53	68	89
Horizontal distance – fastening holes b2 [mm]	49	64	76
Drill holes – depth [mm]	5.8	5.8	7
Drill holes – width f [mm]	11	11	13
Screw connection – M	M5	M5	M6
Weight [kg]	2.9	5.9	8.8

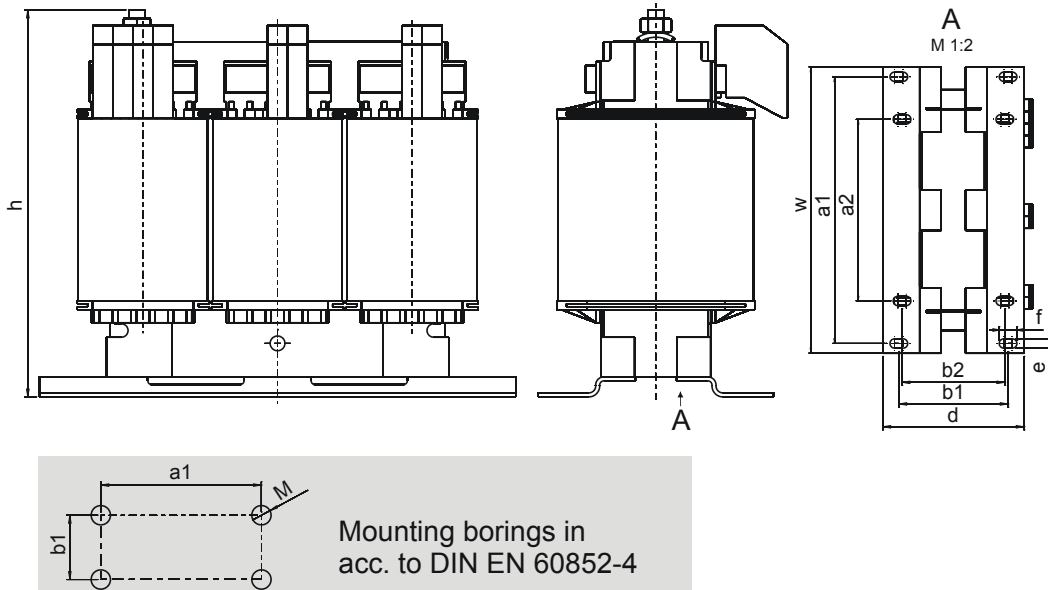

4 Installation

This chapter will give you information about installation. This includes:

- Installation of the inverter in the switching cabinet
- Installation of accessories on or in the inverter

WARNING!

Danger of personal injury and material damage due to electric shock!

- ▶ Always switch off all power supply voltage before working on the inverter! Note that the discharge time of the DC link capacitors is up to 5 minutes. You can only determine the absence of voltage after this time period.

4.1 Installation of the inverter in the switching cabinet

NOTICE

Danger of property damage from incorrect installation of the devices!

- ▶ It is essential to comply with the following installation instructions to avoid damage to the devices.

- The inverters must be installed in a control cabinet with at least protection class IP54.
- The installation location must be free of dust, corrosive vapors and all fluids (in accordance with pollution degree 2 as per EN 60204/EN 50178).
- The installation location must be free of atmospheric moisture.
- Prevent condensation, for example with anti-condensation heating elements.
- For reasons related to EMC, use mounting plates with a conductive surface (unpainted, etc.).
- Fasten the inverters onto the mounting plate with M5 screws.
- The inverters must be installed vertically:

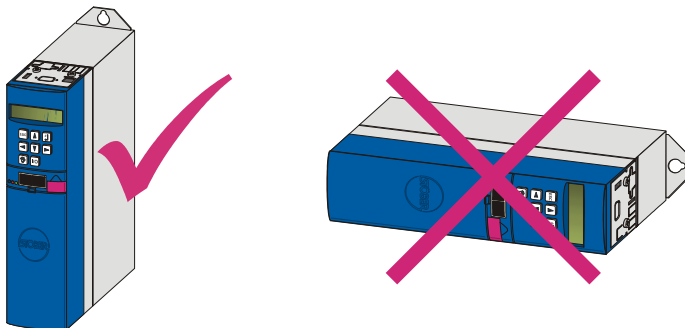



- Avoid installation above or in the immediate vicinity of heat-generating devices, e.g. output chokes or braking resistors:

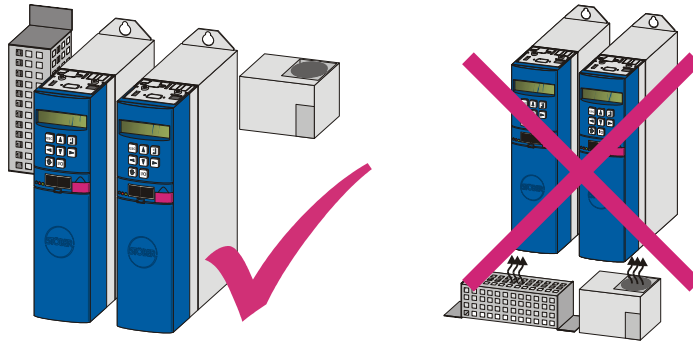

- To ensure there is sufficient air circulation in the control cabinet, observe the minimum clearances.

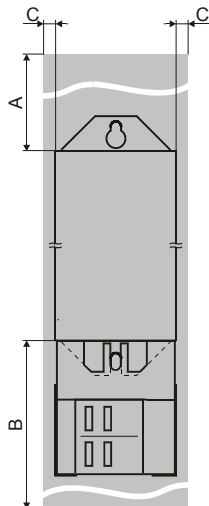

Min. clearance [dimensions in mm]	A Above	B Below	C On the side
Size 0 – size 2	100	100	5
... With EMC shroud or brake module	100	120	5
Size 3	100	100	5
... With EMC shroud	100	220	5

4.2 Accessories

4.2.1 Installation of bottom brake resistor

WARNING!

Danger of personal injury and material damage due to electric shock!

- ▶ Always switch off all power supply voltage before working on the inverter! Note that the discharge time of the DC link capacitors is up to 5 minutes. You can only determine the absence of voltage after this time period.

Requirements:

- You have tapped holes for threaded bolts on the mounting plate in the control cabinet at the installation location, taking into consideration the different device dimensions. The threaded bolts are included with the submounting braking resistor.

You need:

- The threaded bolts included with the submounting brake resistor.
- The screws and washers included with the submounting brake resistor.
- A PH2 Phillips screwdriver.
- An 8 mm hexagonal socket wrench.

Installation of the submounting brake resistor

1. Attach the bottom brake resistor to the mounting plate with the studs:

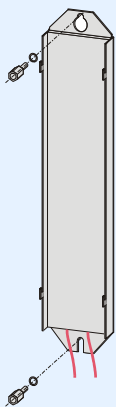

2. Place the device on the guides:

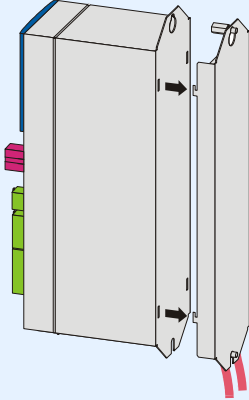

3. Press the device down on the guides:

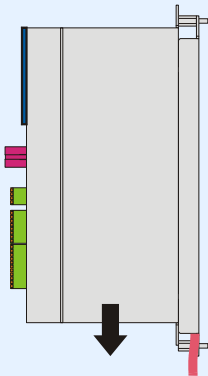

4. Attach the device to the studs with the screws and washers:

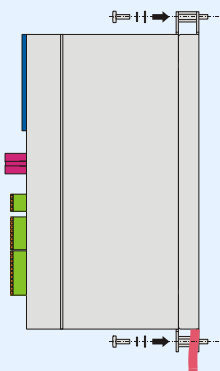

⇒ You have installed the submounting brake resistor.

5. Connect the braking resistor.

Refer to the terminal description X21 for proper connection of the cable, see section 5.10.

6. Parameterize the braking resistor in the inverter.

4.2.2 Installation of EMC shroud or brake module

WARNING!

Danger of personal injury and material damage due to electric shock!

- ▶ Always switch off all power supply voltage before working on the inverter! Note that the discharge time of the DC link capacitors is up to 5 minutes. You can only determine the absence of voltage after this time period.

You can use the EMC shroud EM 5000 for sizes 0 to 2 to connect the cable shield of the power cable. The brake module BRM 5000 or BRS 5001 additionally includes the power electronics for the optional brake controller for one or two 24 V brakes. The EMC shroud and brake module are identical with regard to the mechanical elements. The attachment for both accessory parts on inverters of size 0 to 2 is therefore also the same and is treated in the same way in the following sections.



Information

Brake module BRS 5000 has been replaced by the follow-up model BRS 5001 (from firmware V 5.6-N). You can find more information about both models in section 7. Differences with regard to assembly and connection are described in the relevant section.

Prerequisites (sizes 0 to 2):

- You have already installed the inverter in the switching cabinet.

For attachment you will need:

- A Phillips screwdriver

Installation of EMC shroud EM 5000, brake module BRS 5000 or BRS 5001 on the inverter (size 0, 1 or 2)

1. Remove the bottom mounting screw and washers from the inverter:

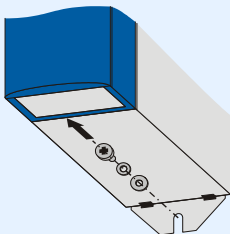

2. Slide the component into the openings at a slight angle:

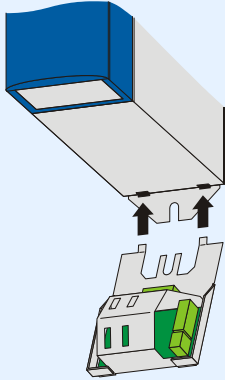

3. Press the back of the component onto the wall of the switching cabinet:

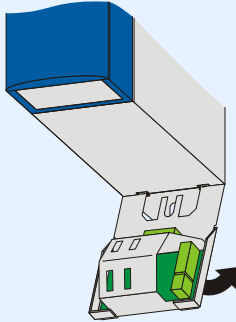

4. Attach the component to the mounting plate and inverter with the mounting screw and the washers:

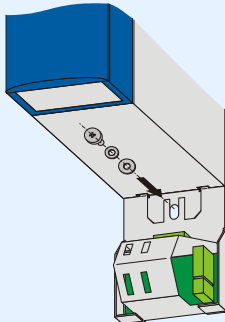

⇒ You have now installed the accessory.

5. **BRS 5001:** It is possible to also attach the component to the mounting plate from below for this variant.

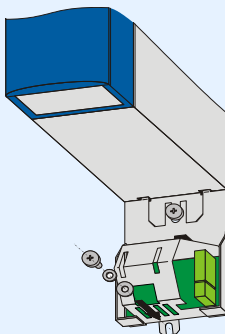

The attachment of brake module BRM 5000 or BRS 5001 to inverters of size 3 is different to the attachment to inverters of size 0 to 2.

For attachment you will need:

- A Phillips screwdriver

Installation of brake module BRS 5000 or BRS 5001 on the inverter (size 3)

1. Remove the mounting screw and washers from the front of the inverter:

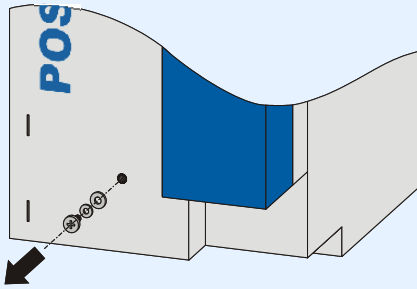

2. Place the component on the device so that the guide rails are in the openings:

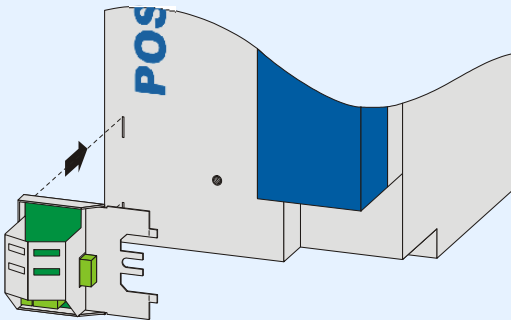

3. Secure the component to the device with the mounting screw and the washers:

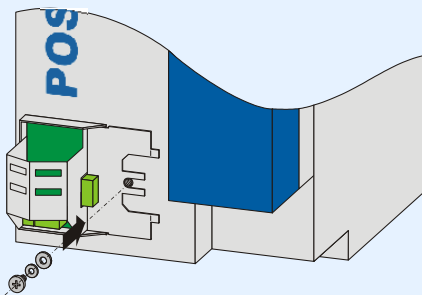

⇒ You have now installed the accessory.



For size 3, the larger EMC shroud EM6A3 for the shield connection of the motor line is available, see section 7 Accessories.

For attachment you will need:

- A Phillips screwdriver
- The two enclosed screws and washers (combination screws with toothed lock washer, M4x8)

Attaching the EMC shroud EM6A3 to an inverter (size 3)

1. Fasten the part onto the bottom of the inverter with the enclosed fastening screws in the tapped holes provided for that purpose (maximum tightening torque: 2.4 Nm).

4.2.3 Installation of the terminal accessories

WARNING!

Danger of personal injury and material damage due to electric shock!

- ▶ Always switch off all power supply voltage before working on the inverter! Note that the discharge time of the DC link capacitors is up to 5 minutes. You can only determine the absence of voltage after this time period.

CAUTION!

Danger of property damage due to electrostatic discharge, among others!

- ▶ Provide suitable protective measures while handling open PCBs (e.g., ESD clothing, environment free of dirt and grease).
- ▶ Do not touch the contact surfaces.

You will need one of the following accessory parts before you can connect binary and analog signals to the inverter. Installation is the same for all four accessory parts.

- SEA 5001, ID no. 49576
- REA 5001, ID no. 49854
- XEA 5001, ID no. 49015

You will need:

- A Phillips screwdriver
- The screws which are pre-mounted on the accessory.

Installation of an SEA 5001, REA 5001 or XEA 5001 in an SDS 5000

1. Unlock the snap catch on the inverter cover:

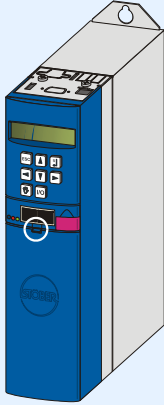

2. Lift up the upper end of the cover from the inverter:

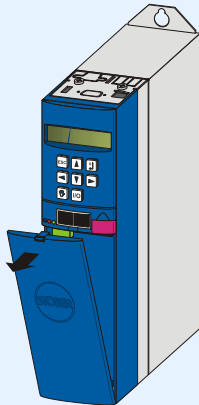

3. Lift the cover up and remove it from the inverter:

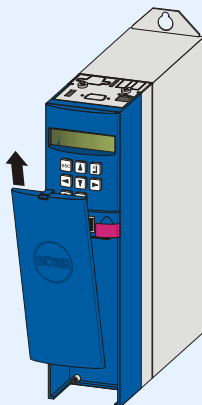

4. Insert the accessory part at a slant with the gold contacts in front. The gold contacts must be in front of the black terminal block.

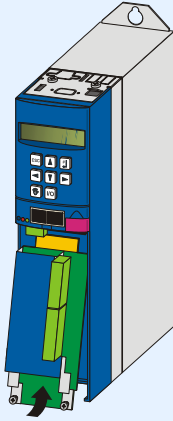

5. Slide the gold contacts into the black connector.

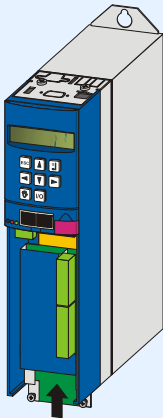

6. Secure the accessory part to the inverter with the mounting screws:

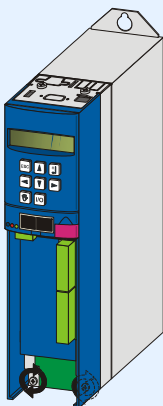

⇒ You have now installed the accessory.

4.2.4 Installation of CANopen, PROFIBUS, EtherCAT or PROFINET accessories

WARNING!

Danger of personal injury and material damage due to electric shock!

- ▶ Always switch off all power supply voltage before working on the inverter! Note that the discharge time of the DC link capacitors is up to 5 minutes. You can only determine the absence of voltage after this time period.

CAUTION!

Danger of property damage due to electrostatic discharge, among others!

- ▶ Provide suitable protective measures while handling open PCBs (e.g., ESD clothing, environment free of dirt and grease).
- ▶ Do not touch the contact surfaces.

You will need the following accessories for the connection of CANopen or PROFIBUS. The accessory part is installed above the inverter's display.

- CANopen: CAN 5000
- PROFIBUS: DP 5000

You will need the following for installation of CAN 5000 or DP 5000.

- A TX10 Torx screwdriver
- A pair of pliers
- Hexagon socket wrench, 4.5 mm

Installation of a CAN 5000 or DP 5000 in an inverter

1. Remove the mounting screws and take off the cover plate:

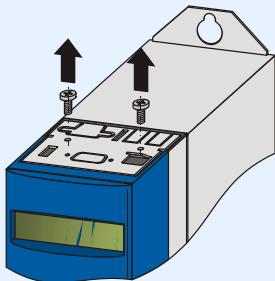

2. Remove the metal plate punch-out with a pair of pliers:

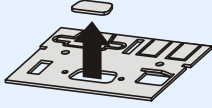

3. Remove the screws from the option board:

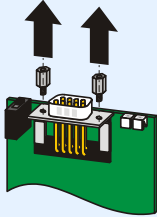

4. From below, thread the sub D plug connector of the PCB through the metal plate:

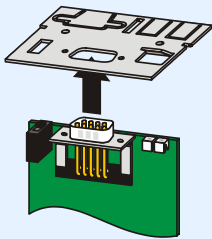

5. Secure the PCB to the metal plate with the screws which you removed in step 3:

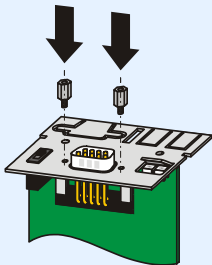

6. Guide the option board into the inverter so that the gold contacts slide into the black connector:

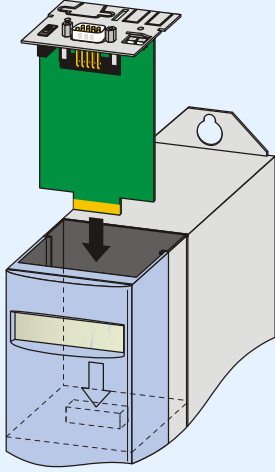

7. Secure the metal plate to the inverter with the mounting screws:

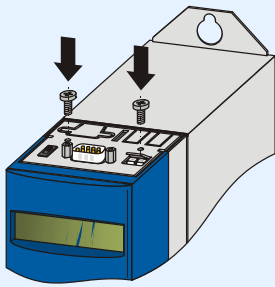

⇒ You have now installed the accessory.



You will need the following accessories for the connection of EtherCAT or PROFINET. The accessory part is installed above the inverter's display.

- EtherCAT: ECS 5000
- PROFINET: PN 5000

You will require the following for installation:

- A TX10 Torx screwdriver
- A Phillips screwdriver
- the following cover plate, which is included in the accessories, is required for installing the ECS 5000:

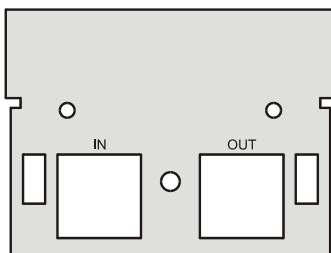

- the following cover plate, which is included in the accessories, is required for installing the PN 5000:

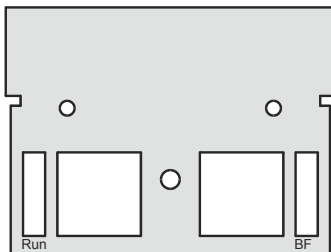

- The screw with locking disk which is included with the ECS 5000 accessories.

Installation of an ECS 5000 or PN 5000 in an inverter

1. Remove the mounting screws and take off the cover plate:

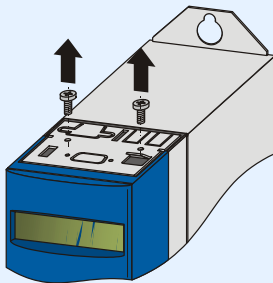

- From below, guide the RJ45 plug connector of the PCB through the metal plate which is included with the accessory:

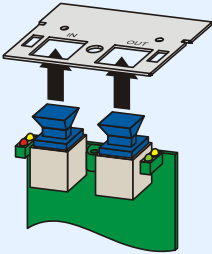

- Secure the metal plate on the PCB with the included screw with locking disk:

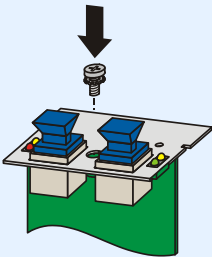

- Guide the option board into the inverter so that the gold contacts slide into the black connector:

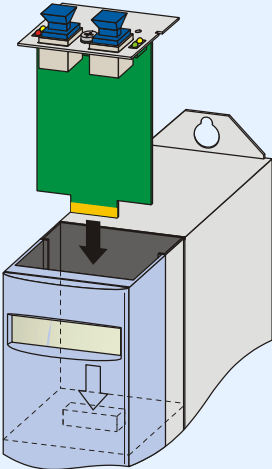

- Secure the metal plate on the PCB with the included screws:

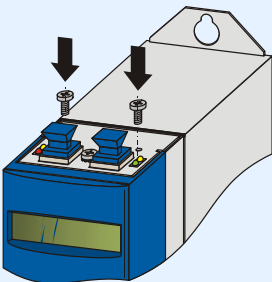

⇒ You have now installed the accessory.



5 Connection

5.1 Overview of terminals

Front and top of the device

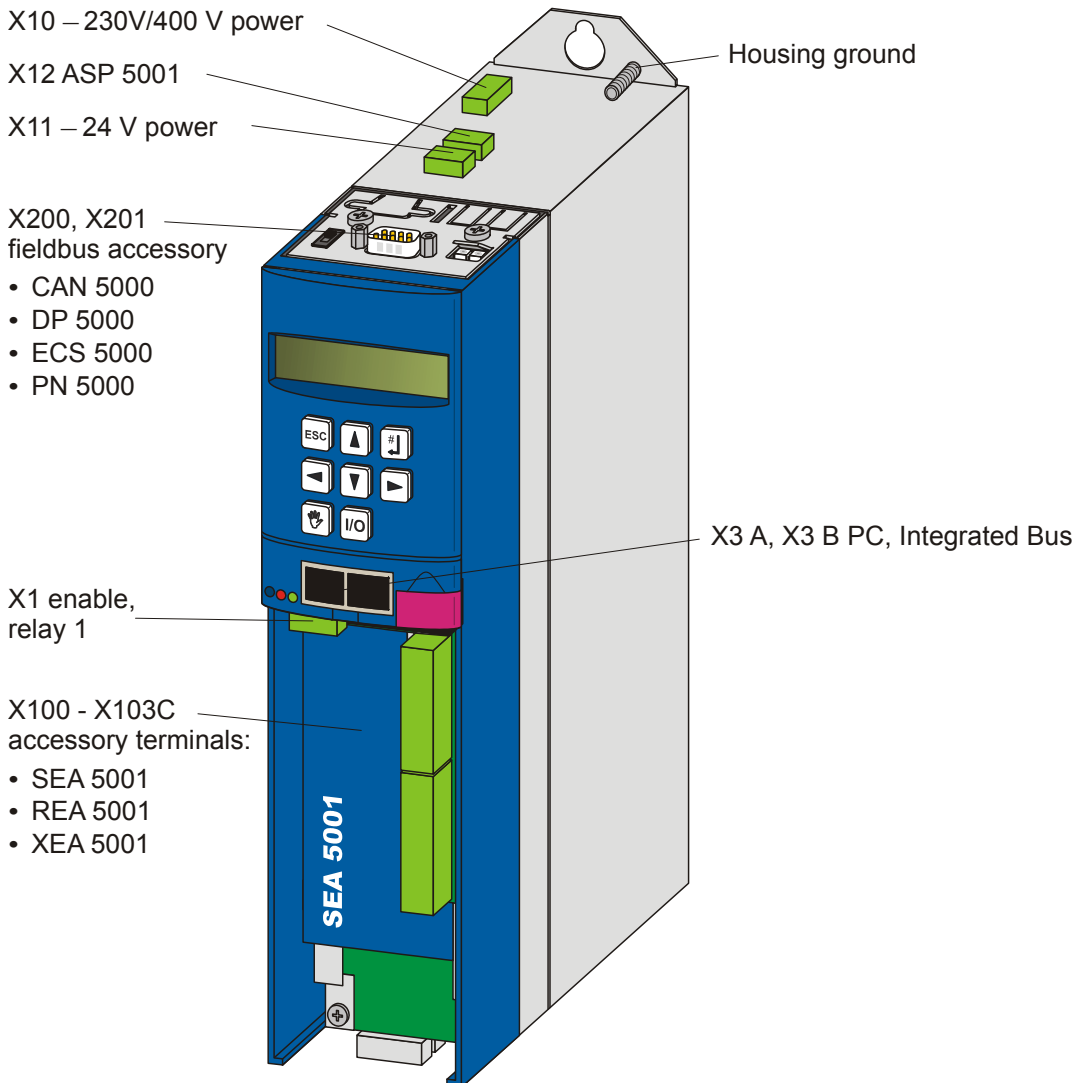

Bottom of the device with BRS 5000

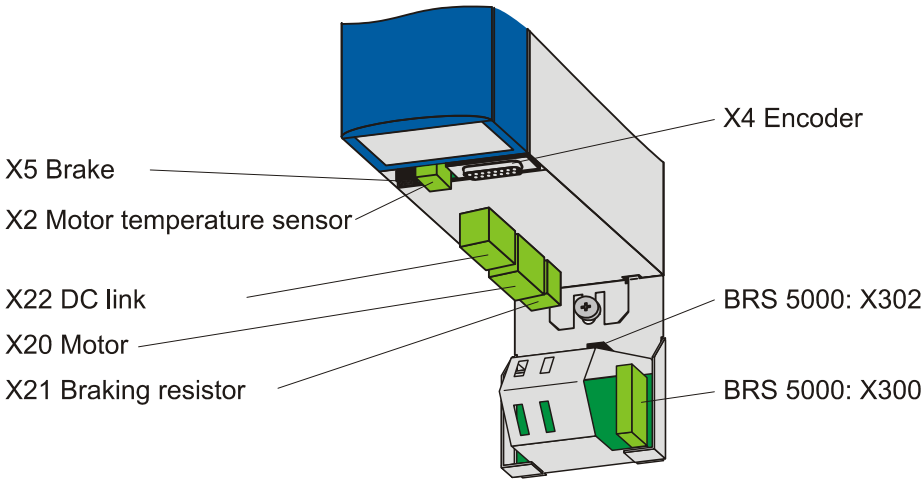

Bottom of the device with BRS 5001

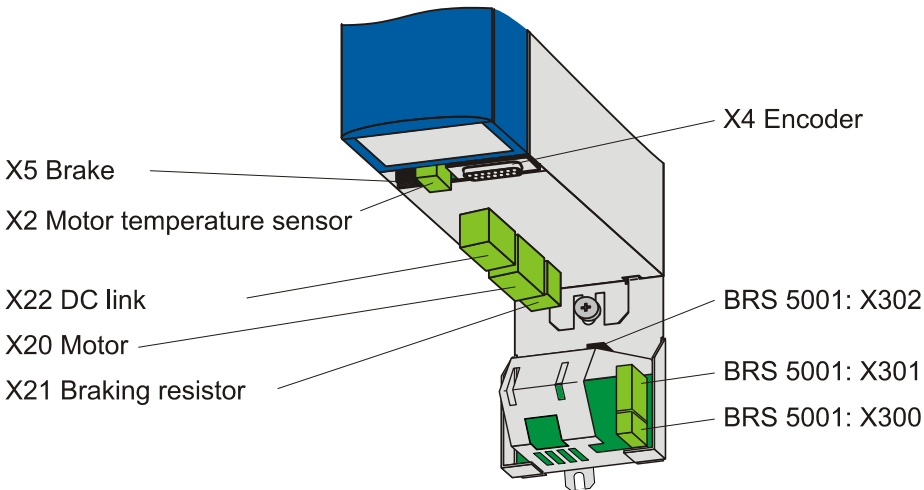



Size 3

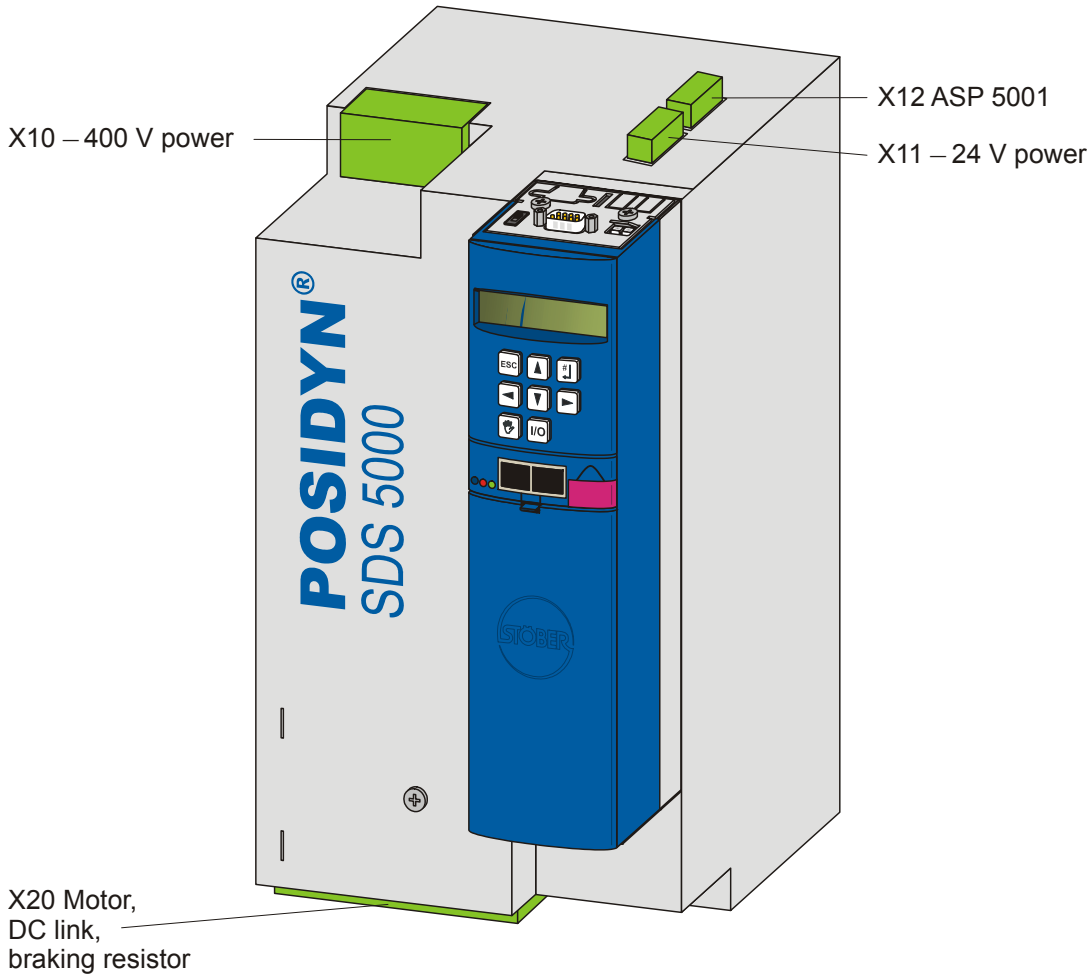

SEA 5001

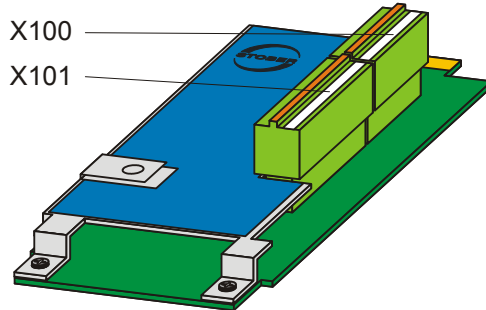

REA 5001

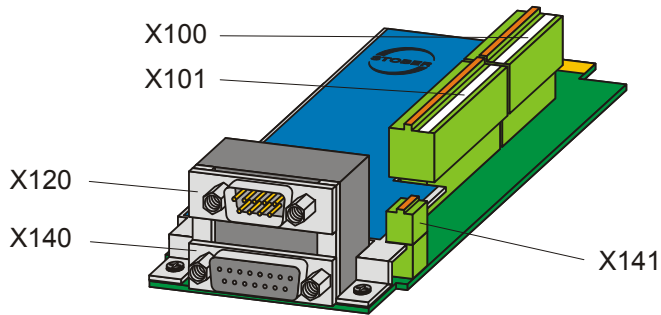

XEA 5001

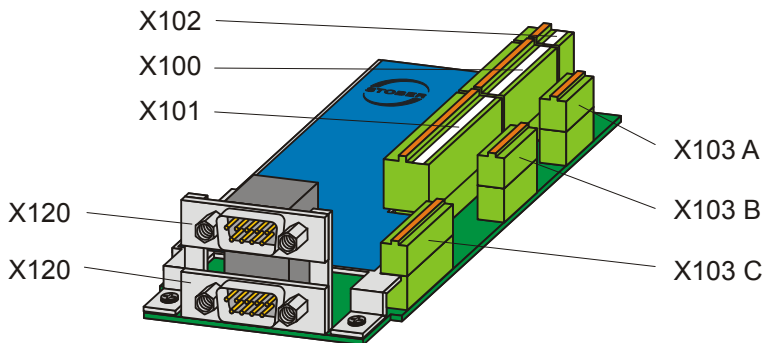

5.2 EMC connection



Information

In this section you can find general information on EMC-compliant installation. This involves recommendations. Depending on the application, ambient conditions as well as the legal requirements, measures beyond these recommendations may be required.



- Lay the power line, motor cable and signal lines separately from each other, e.g. in separate cable channels.
- Only use shielded cables as motor cables. Note also section 5.16 Cables.
- If the brake line is carried in the motor cable, the brake line must be separately shielded.
- Connect the shield of the motor cable with large contact areas and in the immediate vicinity of the inverter. For this purpose, use the EMC shroud EM 5000 or the brake module BRS 5000 or BRS 5001 for the sizes 0 to 2 or the EMC shroud EM6A3 for size 3.
- Shield the cable for connection to a braking resistor if it exceeds a length of 30 cm. In this case, connect the shield with large contact areas and in the immediate vicinity of the inverter.
- For motors with terminal boxes, connect the shield with large contact areas to the terminal box. For example, use EMC cable screw connections.
- Connect the shield of the control lines on one side with the reference ground of the source, e.g. the PLC or CNC.

5.3 X10: 230 V/400 V power

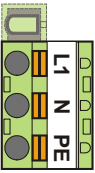
Terminal description – single-phase power connection Size 0

Pin	Designation	Function	Data
	—	Plastic dummy plug	—
	L1	Input voltage	230 V +20 %/-40 % 50/60 Hz
	N	Neutral conductor	—
	PE	Protective ground	—

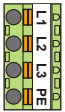
Terminal description – three-phase power connection sizes 0, 1 and 2

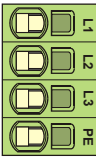
Pin	Designation	Function	Data		
Size 0 	Size 1 	Size 2 	L1 L2 L3 PE	Input voltage Protective ground	3 x 400 V +32 %/-50 % 50 Hz or 3 x 480 V +10 %/-58 % 60 Hz —

Terminal description – three-phase power connection – size 3

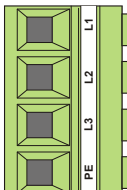
Pin	Designation	Function	Data
	L1	Input voltage	3 x 400 V +32 %/-50 % 50 Hz or 3 x 480 V +10 %/-58 % 60 Hz
	L2		
	L3		
	PE	Protective ground	—

Minimum tightening torque M_{min} – screw-type terminals

Size	Size 1		Size 2		Size 3	
	[Nm]	[lb-in]	[Nm]	[lb-in]	[Nm]	[lb-in]
M_{min}	0.5	4.4	1.2	11	2.5	22

Maximum conductor cross-section of power terminals

Size	0	1	2	3
Maximum cross-section for conductor with ferrule [mm ²]	2.5	4	6 (10 for rigid conductors)	25 (35 for rigid conductors)



5.3.1 Line fuse

The device's cables and output are protected by means of line protection. Various protective devices may be used for this purpose:

- Full range fuse (class "gG" in accordance with IEC class specification or "time lag" in accordance with VDE)
- Line circuit breaker
Use line circuit breaker with trigger characteristics C in accordance with EN 60898.
- Power circuit breaker

Use fuses of class RK1 for UL-compliant applications, for example Bussmann KTS-R-xxA/600 V. For devices of sizes 0 and 1 it is also possible to use fuses of class CC.

Type	Input current $I_{1N,PU}$	Protection rating		
		Recommended	For UL-compliant use	For DC link connection in group 1
SDS 5007	1 x 5.9 A	1 x 10 A	1 x 10 A	1 x 10 A
SDS 5008	3 x 2 A	3 x 6 A	3 x 6 A	3 x 10 A
SDS 5015	3 x 3,7 A	3 x 10 A	3 x 10 A	3 x 10 A
SDS 5040	3 x 9,3 A	3 x 16 A	3 x 15 A	3 x 20 A
SDS 5075	3 x 15,8 A	3 x 20 A	3 x 20 A	3 x 20 A
SDS 5110	3 x 24,5 A	3 x 35 A	3 x 35 A	3 x 50 A
SDS 5150	3 x 32,6 A	3 x 50 A	3 x 50 A	3 x 50 A
SDS 5220 ^{a)}	3 x 37 A	3 x 50 A	3 x 50 A	3 x 80 A
SDS 5370 ^{a)}	3 x 62 A	3 x 80 A	3 x 80 A	3 x 80 A
SDS 5450 ^{a)}	3 x 76 A	3 x 80 A	3 x 80 A	3 x 80 A

a) operation with network commutation reactors and line fuses for operating class gG (full range fuses for cable and circuit protection to IEC 60269-2-1/DIN VDE 0636, part 201 NH fuses)

The inverters are only designed for use on supply current networks which can deliver at the most a maximum of symmetrical rated short circuit current at 480 Volts as per the following table:

Size	Max. symmetrical rated short circuit current
Size 0 and size 1	5000 A
Size 2	5000 A
Size 3	10000 A

5.3.2 Residual current safety device

STÖBER devices can be protected with a Residual Current protective Devices (RCD) to detect residual currents. Residual current protective devices prevent electrical accidents, especially ground fault through the body. They are generally distinguished according to their triggering limit and suitability for detecting different types of residual current.

Depending on the function, stray currents may occur when operating inverters. Stray currents are interpreted as residual currents by residual current protective devices and may therefore lead to false triggering.

Depending on the relevant power supply connections, residual currents may occur with or without a DC current component. Because of this, you should take into consideration both the height and also the shape of the possible stray or residual current when selecting a suitable RCD.



DANGER!

Electric shock hazard!

The combination of single-phase inverters and residual current protective devices type A or AC can lead to false triggering of the RCDs.

Stray currents with a DC current component may occur in 3-phase inverters.

- ▶ Always protect single-phase inverters with *residual current protective devices type B, sensitive to all currents*, or with type F, sensitive to mixed currents.
- ▶ Always protect 3-phase inverters with *residual current protective devices type B, sensitive to all currents*.

False triggering – causes

Depending on stray capacitances and asymmetries, stray currents up to 40 mA may occur during operation. Undesirable false triggering occurs

- ... when inverters to the supply voltage.
This false triggering can be rectified by using short-time delayed (super-resistant), selective (delayed switch-off) residual current protective devices or RCDs with increased trigger current (for example 300 or 500 mA).
- ... Due to higher frequency stray currents for long motor cables under normal operating conditions:
This false triggering can be rectified for example using low-capacitance cables or output deraters.
- ... due to unbalances in the supply network.
This false triggering can be rectified for example using an isolating transformer.



Information

Check whether the use of residual current protective devices with increased trigger current as well as with short-time delayed or delayed switch-off trigger characteristics are permitted in your application.

Installation:

⚠ DANGER!

Electric shock hazard!

Stray and residual currents with a DC current component can restrict the functionality of residual current protective devices types A and AC.

- ▶ Always follow the installation instructions for the protective devices you are using.

5.3.3 Housing ground

5.3.3.1 Size 0 to 2

Note the following information on the connection of the protective earth to ground the housing correctly:

- Note the assembly sequence on the M6 earth bolts (1):
 - 2 Contact disk
 - 3 Cable socket
 - 4 Washer
 - 5 Return spring (optional)
 - 6 Nut

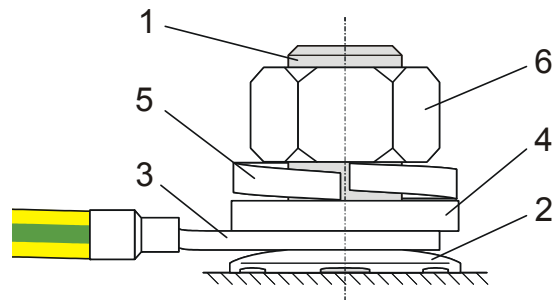

Contact disk, washer, return spring and nuts are supplied with the inverter.

- Tightening torque: 4 Nm
- Stray currents > 10 mA can arise in normal operation.
To fulfill DIN EN 61800-5-1 and EN 60204-1, connect the earth bolts with a copper conductor according to the following table:

Cross-section A Feeder	Minimum cross-section A _p Earth conductor at earth bolts
$A \leq 2.5 \text{ mm}^2$	2.5 mm^2
$2.5 < A \leq 16 \text{ mm}^2$	A
$16 - 35 \text{ mm}^2$	$\geq 16 \text{ mm}^2$
$> 35 \text{ mm}^2$	A/2

5.3.3.2 Size 3

Design the housing earth at interface X10 in at least mm^2 copper or 16 mm^2 aluminum.

5.3.4 Forming

NOTICE

Material damage!

The DC link capacitors in devices of sizes 0, 1 and 2 can lose their electrical strength through long storage times. Considerable material damage can arise from a reduced electrical strength of the DC link capacitors when switching on.

- Use devices in storage annually or before startup.

Perform forming for stored devices.



Information

STÖBER recommends connecting stored devices to the supply voltage according to the wiring shown for one hour every year. Please note that the inverters are designed exclusively for operation in TN networks.

The graphics below show the principle network connection for 3-phase and 1-phase devices.

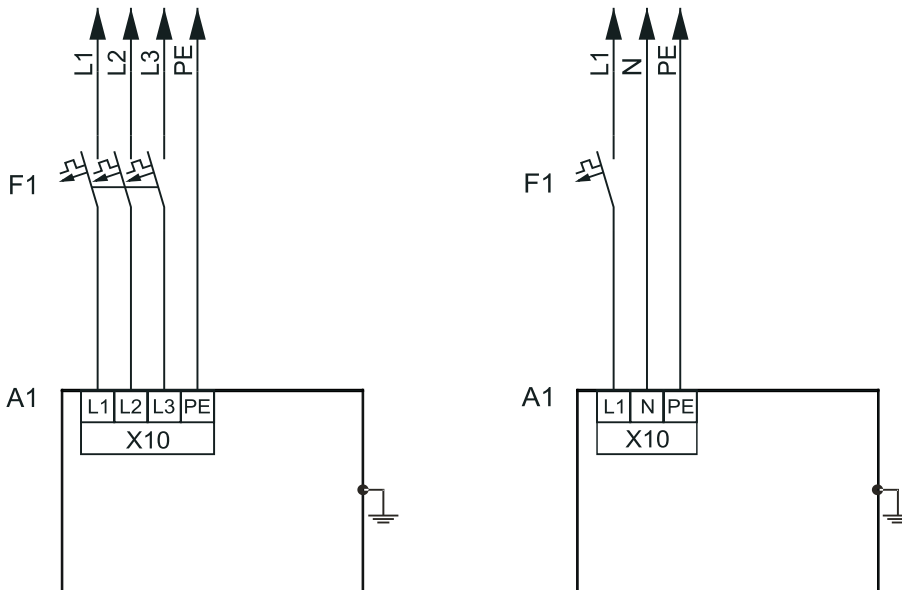

Legend

- L1–L3 = lines 1 to 3
- N = neutral conductor
- PE = protective ground
- F1 = fuse
- A1 = inverter



If annual forming is not possible, form the stored devices before commissioning according to the wiring and voltage levels shown below.

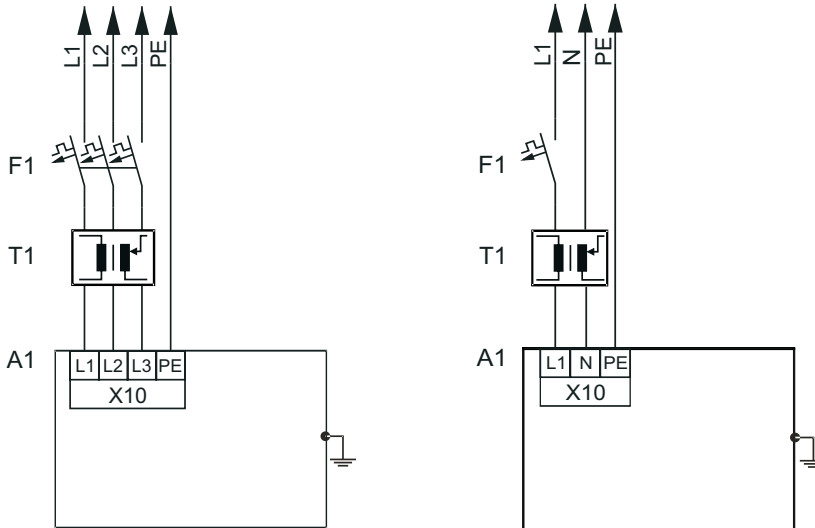

Legend

- L1–L3 = lines 1 to 3
- N = neutral conductor
- PE = protective ground
- F1 = fuse
- T1 = variable transformer
- A1 = inverter

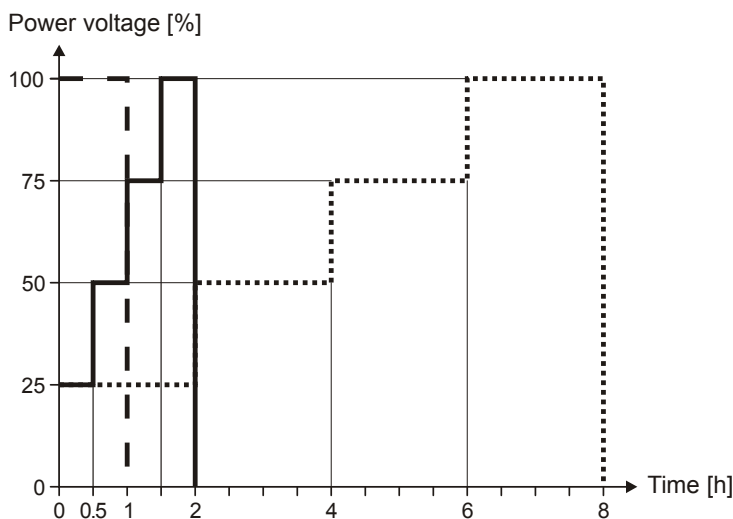

- Storage time 1 - 2 years: Before enabling, apply voltage for one hour.
- Storage time 2 - 3 years: Before enabling, form as per curve.
- Storage time ≥ 3 years: Before enabling, form as per curve.
- Storage time under 1 year: No action required.

5.4 X11: 24 V power

Connection of 24 V to X11 is required for powering the control part.

NOTICE

Danger of damage to the device due to overload!

- ▶ If the 24 V power is looped through, a max. of four devices may be powered on one line.



Information

Remember that, with size 3 devices, the control unit is also powered via the DC link. If, with these inverters, only the 24 V power is switched off, the control electronics are initially still powered via the DC link and continue to run. This can cause problems if the control electronics evaluate the signals of devices which are powered externally and their power is switched off with the 24 V of the inverter (e.g., limit switch or encoder).

Terminal description – size 0, size 1 and size 2

Pin	Designation	Function	Data
	+	+24 V	Auxiliary voltage (PELV) for powering the control electronics
	+	+24 V	
	–	GND	Reference potential for +24 V
	–	GND	
			$U_1 = 20.4 - 28.8 \text{ V}$ $I_{1\text{max}} = 1.5 \text{ A}$

Terminal description – size 3

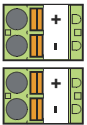
Pin	Designation	Function	Data
	+	+24 V	Auxiliary voltage (PELV) for powering the control electronics
	–	GND	
	+	+24 V	Auxiliary voltage (PELV) for powering the control electronics
	–	GND	
			$U_1 = 20.4 - 28.8 \text{ V}$ $I_{1\text{max}} = 1.5 \text{ A}$

Maximum conductor cross-section

Connection type	Maximum conductor cross-section [mm ²]
Rigid	1.5
Flexible	1.5
Flexible with cable end, without plastic sleeve	1.5
Flexible with cable end, with plastic sleeve	0.5
2 leads with the same cross-section with double cable end	—



Example of connection

If the 24 V power is looped through, a max. of four devices may only be powered on one line. For conformity with UL, a 4 A fuse must be used on the 24 V incoming line. The fuse must be approved as per UL 248.

Size 0, size 1 and size 2

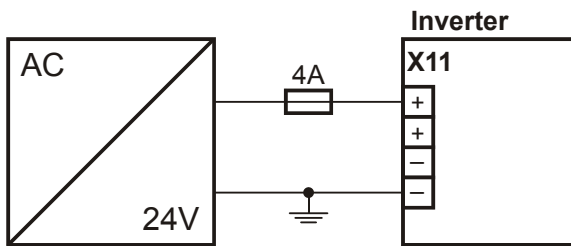

Size 3

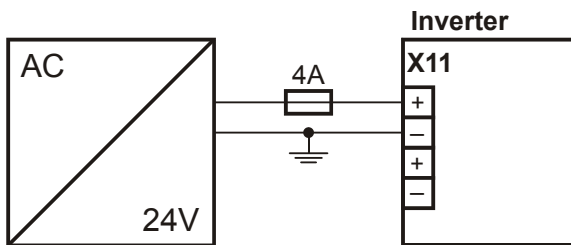

Example of the connection of two devices

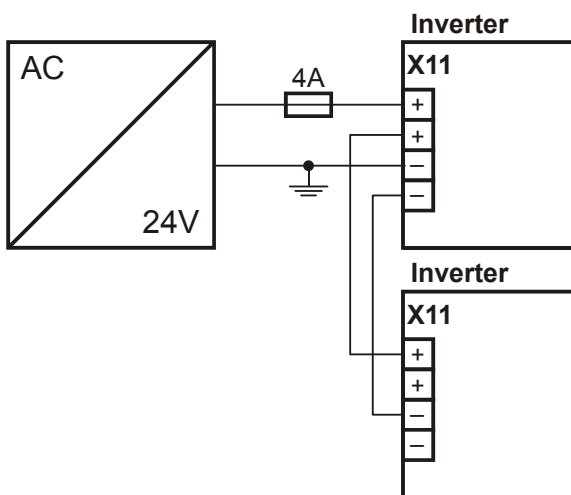

5.5 X1: Enable and relay 1

Use the enable signal to enable the power pack of the inverter. Starting with V 5.5-C, the function of relay 1 can be adjusted in parameter *F10*.

General specification

Maximum cable length	30 m
----------------------	------

Terminal description

Pin	Designation	Function	Data	
	1	Contact 1	Relay 1 $U_{\max} = 30 \text{ V}$ $I_{\max} = 1.0 \text{ A}$ Life expectation (number of switching operations): <ul style="list-style-type: none"> Mechanical min. 5 000 000 switching operations; at 24 V/1A (ohm. load): 300 000 switching operations. Recommended fuse: max. 1 A (time lag)	
	2	Contact 2		
	3	GND	Enable power board	High level $\geq 12 \text{ V}$ Low level $< 8 \text{ V}$ $I_{1\max} = 16 \text{ mA}$ $U_{1\max} = 30 \text{ V}$
	4	+ input		

Maximum conductor cross-section

Connection type	Maximum conductor cross-section [mm ²]
Rigid	1.5
Flexible	1.5
Flexible with cable end, without plastic sleeve	1.5
Flexible with cable end, with plastic sleeve	0.5
2 leads with the same cross-section with double cable end	—



Example of connection

For a UL-compliant application, the use of a 1 A fuse before relay 1 is mandatory. The fuse must be approved as per UL 248.

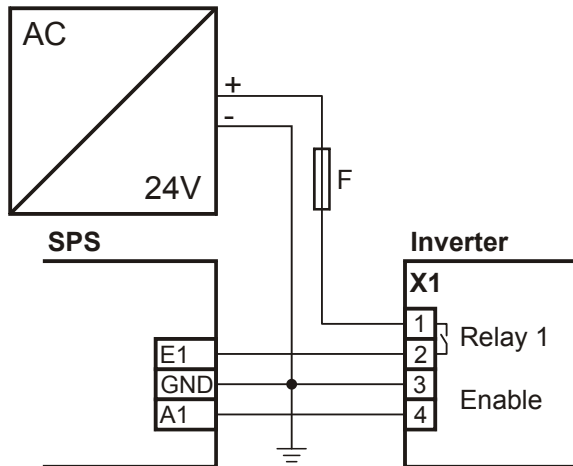

5.6 X20: Motor

Terminal description - size 0, size 1 and size 2

Pin	Designation	Function
Size 0	U	Motor connection, phase U
Size 1	V	Motor connection, phase V
Size 2	W	Motor connection, phase W
	PE	Protective ground

Terminal description – size 3 (with braking resistor and DC link connection)

Remember that with size 3 in addition to the motor the braking resistor and the DC link are also connected to terminal X20.

Pin	Designation	Function
	RB-	Braking resistor connection (see chapter X21: Braking Resistor)
	RB+	
	W	Motor connection, phase W
	V	Motor connection, phase V
	U	Motor connection, phase U
	ZK-	Reference potential for DC link
	ZK+	+ Potential of DC link
	PE	Protective ground

Minimum tightening torque M_{\min} – screw-type terminals

Size	Size 1		Size 2		Size 3	
Unit	[Nm]	[lb-in]	[Nm]	[lb-in]	[Nm]	[lb-in]
M_{\min}	0.5	4.4	1.2	11	2.5	22

Maximum conductor cross-section of power terminals

Size	0	1	2	3
Maximum cross-section for conductor with ferrule [mm ²]	2.5	4	6 (10 for rigid conductors)	25 (35 for rigid conductors)

Maximum motor cable length

Size	0 to 2	3
Without output derater	50 m	100 m
With output choke	100 m	—

Connection without output derater

Observe the following points when connecting the motor without the output derater:

- Ground the shield of the motor cable with the shield connection clamp on the EMC shroud.
- Keep the exposed conductor as short as possible. All devices and circuits that are sensitive to EMC must be kept at a distance of at least 0.3 m.

Connection with output derater

Observe the following points when connecting the motor to the output derater:

- Ground the shield of the motor cable with large area contacts in the immediate vicinity of the output derater, for example with electrically conductive metal cable terminals on a grounded connection rail.
- Keep the exposed conductor as short as possible. All devices and circuits that are sensitive to EMC must be kept at a distance of at least 0.3 m.

The graphic below shows an example for the shielded connection of a motor with output derater (graphic: icotek GmbH).

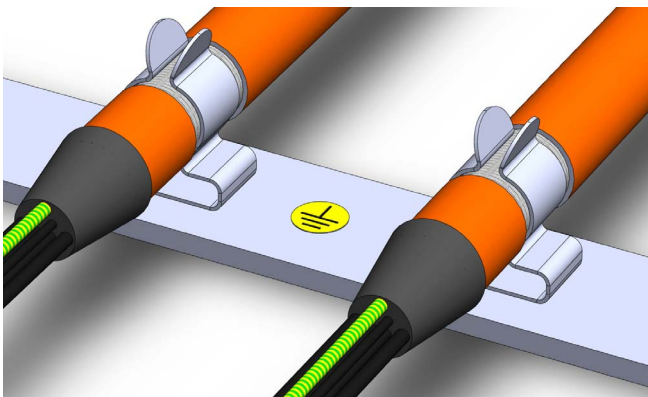

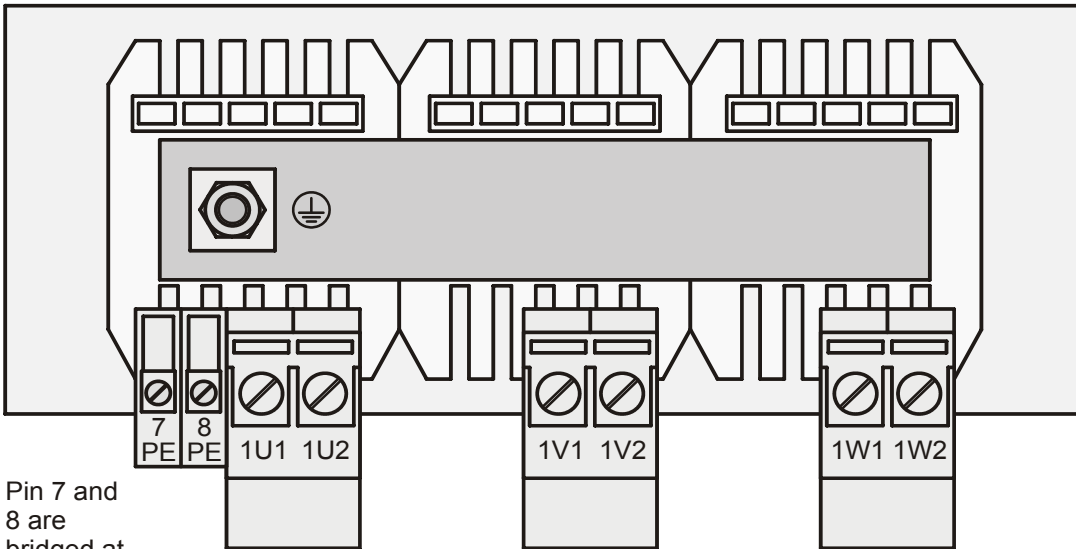

Pin 7 and 8 are bridged at the output derator

Example of connection

PES: HF shield connection via large-surface connection to PE

Inverter

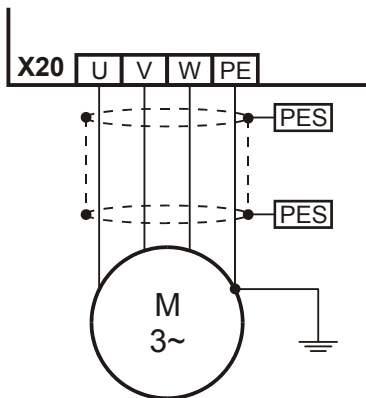

5.7 X12: ASP 5001 – Safe Torque Off



Information

If you are going to use this safety function, you will need the ASP 5001 option. It is imperative you read the operating instructions ASP 5001 (see section 1.2 Further documentation) and integrate the safety technology in your safety circuit in accordance with the description given there. Note that for devices of size 2 and size 3 the ASP 5001 option is fitted as standard. Even if you do not use safety technology, the inverter cannot be placed in operation if you leave the ASP 5001 option unconnected! Therefore connect the ASP 5001 option as per the following description if you are not using any safety technology.



Information

Please remember that the following description only applies to the ASP 5001. Go to applications@stoerber.de for the description of the ASP 5001.

Terminal description X12

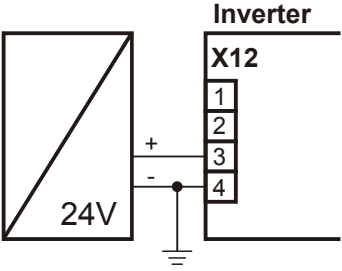
Pin	Des.	Function	Data	Circuiting (If safety technology is not used!)
1	NC contact (break contact element)	Feedback contact; must be integrated in the safety circuit of the controller!	Note the specifications in the operating instructions ASP 5001, see section 1.2 Further documentation.	
2				
3	Relay coil+	Activation ^{a)}	$U_1 = 20.4 - 28.8 V_{DC}$ (PELV) $I_{1Typ} = 50 \text{ mA}$ $I_{1max} = 70 \text{ mA}$ Note the specifications in the operating instructions ASP 5001, see section 1.2 Further documentation.	
4	Relay coil-			

a) To conform with UL, a 4 A delayed fuse must be used in the 24 V feeder line. The fuse must be approved in accordance with UL 248.

Maximum conductor cross-section

Connection type	Maximum conductor cross-section [mm ²]
Rigid	1.5
Flexible	1.5
Flexible with cable end, without plastic sleeve	1.5
Flexible with cable end, with plastic sleeve	0.5
2 leads with the same cross-section with double cable end	—

5.8 X2; X141: Motor temperature sensor

Connect the motor temperature sensor at terminal X2.

Motor temperature sensor connection

Motor windings are monitored thermally using the motor temperature sensors such as PTC or KTY sensors.

PTC sensors are thermistors and their resistance changes significantly with the temperature. When a PTC reaches its defined nominal response temperature, the resistance increases dramatically, by twice or more the original resistance to several kOhms. PTC sensors therefore allow for effective motor protection.

On the other hand, *KTY sensors* are temperature sensors with characteristic resistance curves that follow the temperature almost linearly. KTY sensors therefore allow for analog measurements of motor temperatures. However, the measurements are limited to one motor winding, which also restricts motor protection considerably compared with PTC drillings.



Information

Note that the evaluation of a KTY84-130 on the SDS 5000 is possible with a hardware version of 200 or higher. Before using a KTY, note that motor protection is not ensured to the same extent as when monitoring with PTC drilling.

Motor temperature sensor lines in the resolver or EnDat cable (SDS 4000)

If you replace a SDS 4000 with a MDS or SDS 5000, the lines of the motor temperature sensor are carried in the previously used resolver or EnDat cable. To be able to continue using the cable, you will need the accessory part REA 5001 (see section 7 Accessories).

You can connect the EnDat cable directly to the REA 5001. You can connect the nine pole resolver cable using the resolver adapter included in the scope of delivery of the REA 5001 (see section 7 Accessories). The signal of the motor temperature sensor is output on the REA 5001 to the interface X141. In this case connect X141 to X2.

**Information**

Note that evaluation of the temperature sensors is always active. If operation without temperature sensor is permitted, the connections must be bridged on X2. Otherwise a fault will be triggered when the device is switched on.

Terminal description – X2

Pin	Function	Data
	1	1TP1/1K1+
	2	1TP2/1K2-
		Max. 2 PTC triplets (series-connected) or one KTY84-130

Maximum conductor cross-section

Connection type	Maximum conductor cross-section [mm ²]
Rigid	2,5
Flexible	2,5
Flexible with cable end, without plastic sleeve	2,5
Flexible with cable end, with plastic sleeve	2,5
2 leads with the same cross-section with double cable end	1,5

Terminal description – X141

Pin	Function	Description
	1	1TP1/1K1+
	2	1TP2/1K2-
		Thermal motor protection signal, comes from X140 pin 7
		Thermal motor protection signal, comes from X140 pin 14

Maximum conductor cross-section

Connection type	Maximum conductor cross-section [mm ²]
Rigid	1,5
Flexible	1,5
Flexible with cable end, without plastic sleeve	1,5
Flexible with cable end, with plastic sleeve	0,75
2 leads with the same cross-section with double cable end	—



Example of connection of X2

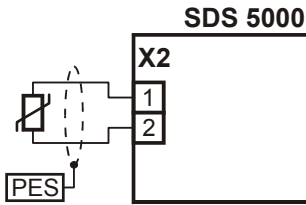

Example of connection of X141 and X2

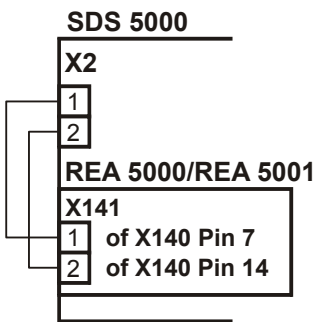

5.9 X5; X300 - X302: Motor holding brake

The inverter SDS 5000 can control one or two motor holding brakes. Usually brake 1 is the motor-internal brake and brake 2 the one in the motor adapter ServoStop. STÖBER ANTRIEBSTECHNIK GmbH & Co. KG offers the motor adapter ServoStop as an option for servo geared motors.

Requirement for the connection of motor holding brakes on the SDS 5000:

- The accessory part BRS 5000 or the BRS 5001, from firmware V 5.6-N, see section 7
- The enclosed connection cable (X5, X302)



Information

Remember that motor halting brakes of other manufacturers may not be connected to the BRS 5000 or BRS 5001 without first consulting STÖBER.



Information

Remember that you may only make the connection between X5 and X302 with the connection cable included with the BRS 5000 or BRS 5001.



Information

Remember that two LEDs are installed on the brake module. These LEDs indicate the status of the brake control:

- LED on: brake output, energized (active)
- LED off: brake output, not energized (inactive)

Terminal description X5 (inverter) and X302 (BRS 5000 or BRS 5001)

Pin	Designation	Function	
	1	1BD1	Brake 1 controller
	2	1BD2	Reference potential at pin 1, 2, 5 and 6
	3	Status1	Brake 1 feedback
	4	Status2	Brake 2 feedback
	5	2BD2	Reference potential at pin 1, 2, 5 and 6
	6	2BD1	Brake 2 controller

Maximum conductor cross-section

Connection type	Maximum conductor cross-section [mm ²]
Rigid	2,5
Flexible	2,5
Flexible with cable end, without plastic sleeve	2,5
Flexible with cable end, with plastic sleeve	2,5
2 leads with the same cross-section with double cable end	1,5

Terminal description X300 (BRS 5000)

Pin	Designation	Function	Data
	1	1BD1	Control brake 1 $I_2 \leq 2,5 \text{ A}$: max. of 15 switching cycles per minute $I_2 \leq 3,6 \text{ A}$: max. of 10 switching cycles per minute $I_{2\text{max}} = 3,6 \text{ A}$
	2	1BD2	Reference potential for brake 1 —
	3	2BD1	Control brake 2 $I_2 \leq 2,5 \text{ A}$: max. of 15 switching cycles per minute $I_2 \leq 3,6 \text{ A}$: max. of 10 switching cycles per minute $I_{2\text{max}} = 3,6 \text{ A}$
	4	2BD2	Reference potential for brake 2 —
	+	24 V	Feedin for brake control $U_1 = 24\text{--}30 \text{ V}$ $I_{1\text{max}} = 7,5 \text{ A}$ Fuses: Up to a max. of 10 AT in acc. with the brakes used
	-	GND	Reference potential for 24 V —



Information

Note that the 24-V power supply on X300 Pin + must always be at least 24 V. If the voltage falls below 24 V, a malfunction is triggered in the inverter.
Connect a controlled 24-V power supply to X300 Pin +.

Maximum conductor cross-section

Connection type	Maximum conductor cross-section [mm ²]
Rigid	2,5
Flexible	2,5
Flexible with cable end, without plastic sleeve	2,5
Flexible with cable end, with plastic sleeve	2,5
2 leads with the same cross-section with double cable end	1,5

Terminal description X300 (BRS 5001)

Pin	Designation	Function	Data
	+	24 V	Power input for brake controller
	—	GND	Reference potential for 24 V
			$U_1 = 24 - 30 \text{ V}$ $I_{1\text{max}} = 7.5 \text{ A}$ Fuse: up to max. 10 AT according to brakes used

Terminal description X301 (BRS 5001)

Pin	Designation	Function	Data
	1	1BD1	Controller Brake 1
	2	1BD2	Brake 1 reference potential
	3	2BD1	Controller Brake 2
	4	2BD2	Brake 2 reference potential
			$I_2 \leq 3.6 \text{ A}$: max. 15 operating cycles per min. $I_{2\text{max}} = 3.6 \text{ A}$

**Information**

Note that the 24-V power supply on X300 Pin + must always be at least 24 V. If the voltage falls below 24 V, a malfunction is triggered in the inverter.

Connect a controlled 24-V power supply to X300 Pin +.

Maximum conductor cross-section

Connection type	Maximum conductor cross-section [mm ²]
Rigid	2,5
Flexible	2,5
Flexible with cable end, without plastic sleeve	2,5
Flexible with cable end, with plastic sleeve	2,5
2 leads with the same cross-section with double cable end	1,5

Brake connection with BRS 5000 for 24 V DC brakes

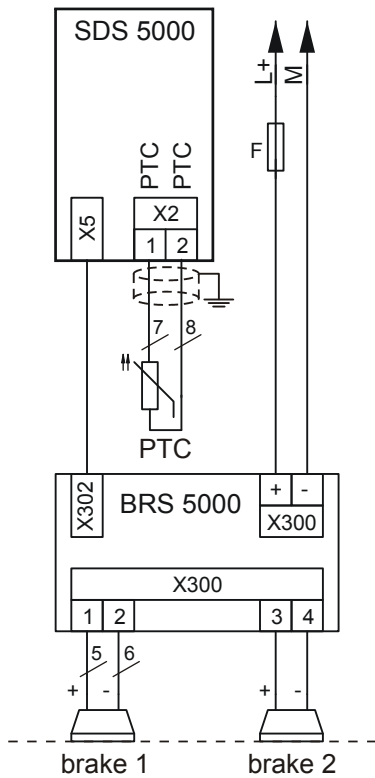

Indirect brake control

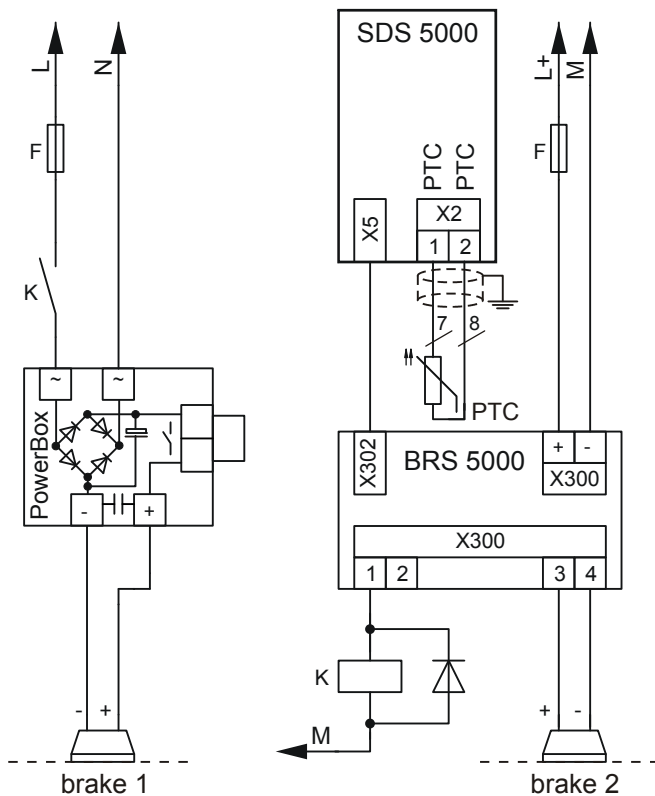

Brake connection with BRS 5001 for 24 V DC brakes

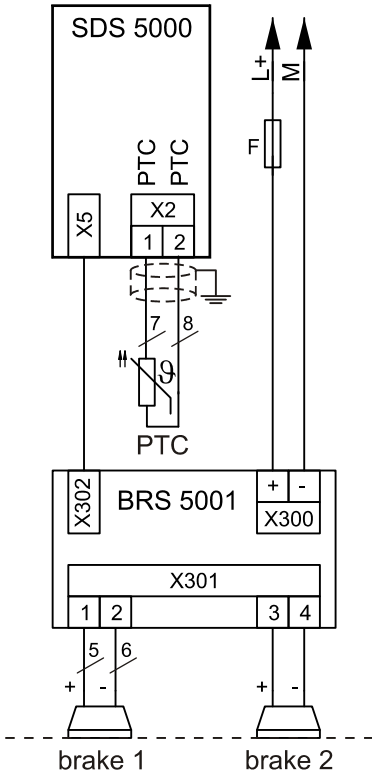

Indirect brake control

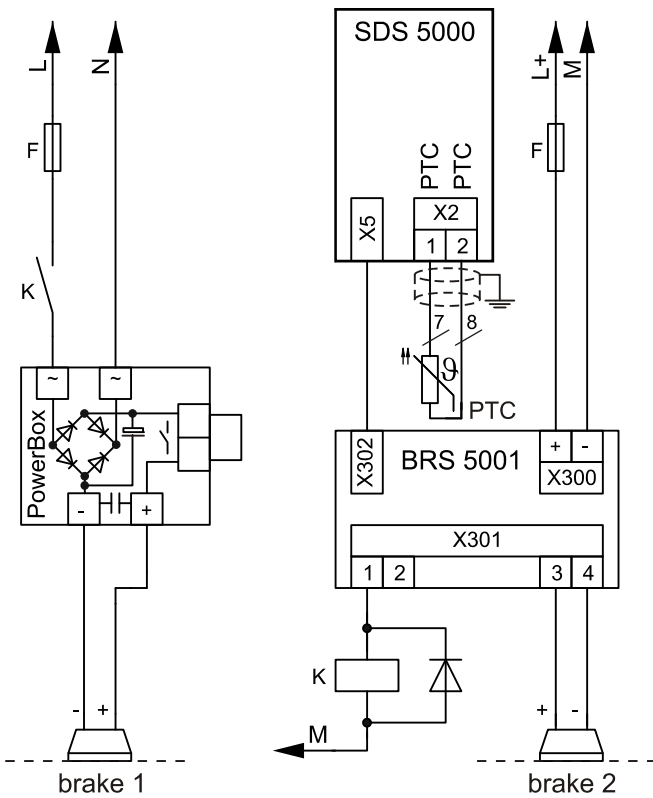

WE KEEP THINGS MOVING

5.10 X21: Braking resistor

An external braking resistor may be necessary during generating operation. For the technical data on the braking resistors, see chapter 3 Technical data. The braking resistor is connected to terminal X20 on size 3 versions (chapter 5.6 X20: Motor).

Terminal description – size 0 to size 2

Pin			Designation	Function
Size 0	Size 1	Size 2	RB	Connection of braking resistor
			RB	

Minimum tightening torque M_{min} – screw-type terminals

Size	Size 1		Size 2	
Unit	[Nm]	[lb-in]	[Nm]	[lb-in]
M_{min}	0.5	4.4	1.2	11

Maximum conductor cross-section of power terminals

Size	0	1	2	3
Maximum cross-section for conductor with ferrule [mm ²]	2.5	4	6 (10 for rigid conductors)	25 (35 for rigid conductors)

Example of connection

Use a shielded cable for cables longer than 30 cm between braking resistor and device.

Inverter

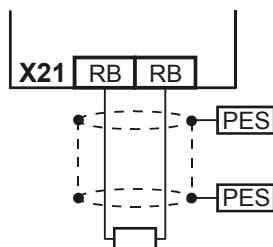

5.11 X22: DC link coupling



Information

Remember that the DC link coupling described here can only be used with the device families MDS 5000, SDS 5000 and FDS 5000.

When you have axes in your system which operate in combination and are continuously regenerative and motor-driven, the DC link coupling may offer advantages. The DC link coupling takes the excess power and offers it to other axes as drive power instead of converting it into heat via a braking resistor. Remember that you will need a braking resistor to absorb the power peaks when all drives in the DC link coupling brake at the same time.



DANGER!

Danger of device damage! When single-phase and three-phase devices are coupled, the single-phase devices will be destroyed.

- ▶ Only use three-phase devices for the DC link coupling!

NOTICE

Danger of device damage!

Because the failure of one device could damage other devices, failure of a device must cause the entire DC link compound system to be disconnected from the power supply.

- ▶ Make a note of the wiring and parameterization of relay 1 in Section Principal circuit diagram (X1.1 and X1.2).
- ▶ After a failure, replace all the devices in a group.



Information

Remember that the parameter *A38 DC power-input* must be set before the DC link coupling can function correctly:

Group 1: *A38 = 0: inactive*

Groups 2 and 3: *A38 = 1: active*

See the description of the parameter.

Terminal description X22 – size 0, size 1 and size 2

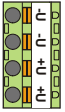
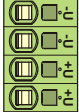
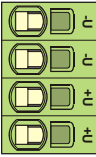
Pin			Designation	Function
Size 0	Size 1	Size 2	-U	Reference potential for DC link
			-U	
			+U	+ Potential of DC link
			+U	

Size 3: For connection to terminal X20, see 5.6 X20: Motor

Minimum tightening torque M_{min} – screw-type terminals

Size	Size 0		Size 1		Size 2	
	[Nm]	[lb-in]	[Nm]	[lb-in]	[Nm]	[lb-in]
M_{min}	0.5	4.4	0.5	4.4	1.2	11

Maximum conductor cross-section of power terminals

Size	0	1	2	3
Maximum cross-section for conductor with ferrule [mm ²]	2.5	4	6 (10 for rigid conductors)	25 (35 for rigid conductors)

Principal circuit diagram

The following circuit diagram shows the principal circuit diagram of the DC link coupling. The inverters can be linked together in up to three groups. The table on the next page shows the possible combinations. The combination determines the types of line fuses and the DC link fuse.

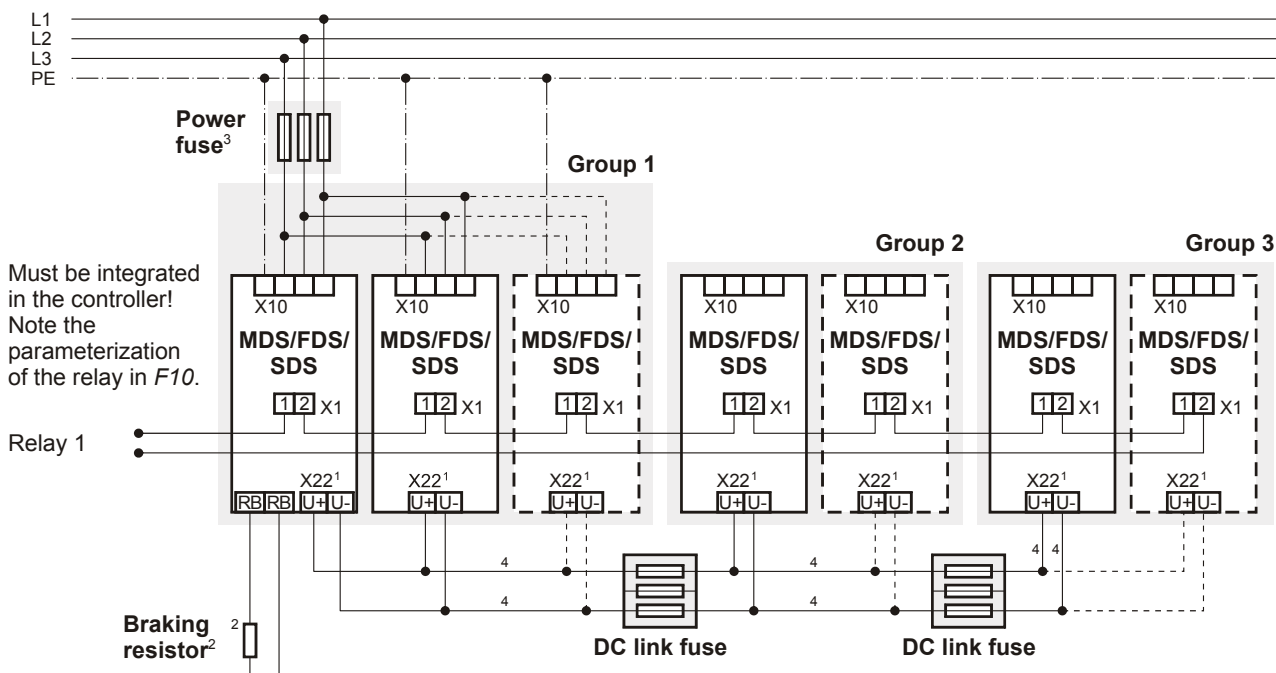

- 1 With size 3 MDS 5000 and SDS 5000 devices: X20, terminals ZK+, ZK-.
- 2 Dimension the braking resistor in accordance with the braking performance of the DC link coupling and the technical data of the device.
- 3 See chapter 5.3.
- 4 Dimension the conductor cross-sections of the DC link connection according to the requirements of your application. A reference point can be the maximum cross-section for the terminals X22 for size 0 to 2 or X20 for size 3.



Combinations

The following table shows the possible combinations for the DC link connection. There are a total of 15 combinations available.

Example: Combination no. 7:

With combination no. 7, you can combine an inverter of size 1 in group 1 with two devices of size 0 in group 2. Group 3 is not set up. The line fuse must have a rated current of 20 A. The groups are separated via the DC link fuse of type 1. Wait three minutes before switching on the devices of the DC link connection again.

Device family	Group 1				DC link fuse	Group 2		DC link fuse	Group 3	t_{\min} ^{a)}
	MDS/FDS/SDS	MDS/SDS				MDS/FDS/SDS				
Size	Size 0	Size 1	Size 2	Size 3		Size 0	Size 1		Size 0	
Line fuse	10 A	20 A ^{b)}	50 A ^{b)}	80 A ^{b)}		—	—		—	
$P_{2\max PU}$ ^{c)}	4 kW	10 kW	20 kW	45 kW		—	—		—	
Combination no.										
1	Max. 4	—	—	—	—	—	—	—	—	1
2	—	Max. 4	—	—	—	—	—	—	—	5
3	—	3	—	—	Type 1	2	—	—	—	5
4	—	3	—	—	Type 1	1	—	—	—	3
5	—	2	—	—	Type 1	2	—	—	—	3
6	—	2	—	—	Type 1	1	—	—	—	4
7	—	1	—	—	Type 1	2	—	—	—	3
8	—	—	Max. 3	—	—	—	—	—	—	2
9	—	—	3	—	Type 2	—	1	Type 1	2	2
10	—	—	3	—	Type 1	2	—	—	—	2
11	—	—	3	—	Type 2	—	1	—	—	2
12	—	—	2	—	Type 2	—	1	—	—	2
13	—	—	2	—	Type 2	—	1	Type 1	1	2
14	—	—	1	—	Type 2	1	—	—	—	2
15	—	—	—	Max. 3	—	—	—	—	—	1

a) Restart time

b) Note the list of line fuses for UL-compliant use in section 5.3.1 Line fuse

c) Maximum sum of drive power

Instead of delaying the process by the restart time, you can determine the restart time by evaluating the *E14* parameter. The parameter in all devices connected to the network must show that the load relay is open before the supply voltage may be switched on again. You can query the parameter via the fieldbus or binary output. If you are setting up a DC link connection only with devices from the SDS 5000 family or A-devices (HW version 200 or higher), you do not need to note the restart time.

Fuses

CAUTION!

Danger of machine standstill! If a fuse element fails, the second fuse element will be damaged.

- ▶ Always replace the elements of a fuse in pairs.

Remember the following points during mounting and operation:

- Shield the DC link connections if the cables are longer than 20 cm. This prevents EMC problems.
- Use the two outer elements of the fuse holder to ensure adequate safe flashover distance.
- Use the following fuses to protect the DC link:

	Type 1	Type 2
Manufacturer	SIBA Sicherungs-Bau GmbH Borker Straße 22 D-44534 Lünen www.siba.de	
Size	10 x 38	
Operating class	gRL	
Rated voltage	AC 600 V	
Rated current	10 A	20 A
Power loss per element	1.6 W	3.5 W
Art. no. of fuse	6003434.10	6003434.20
Art. no. of fuse holder	5106304.3	

5.12 X100 - X103: Analog and binary signals

Below are the prerequisites for connecting analog and binary signals:

- SEA 5001
- REA 5001
- XEA 5001

 **WARNING!**

Danger of faulty machine behavior due to EMC faults!

- ▶ Use exclusively cables up to 30 m in length for analog and binary inputs and outputs (AE, AA, BE, BA)!



Information

Note that the sampling time of the inputs and the refresh rate of the outputs correspond to the cycle time set in parameter *A150*.

For time critical functions such as a print mark control, a time stamp is also available for the binary inputs.

If BE encoders or BA encoder simulation is used, the sampling time and refresh rate is independent of the set cycle time (see section 5.13.4 BE encoder and BA encoder simulation).

Terminal description X100 – SEA 5001, REA 5001, XEA 5001

NOTICE

Machine movement by unexpected reference value

The inverter detects a reference value setting of +5V for an unconnected analog input.

- ▶ Always operate the inverter with a connected analog input.

General specification

Maximum cable length	30 m, shielded
----------------------	----------------

Terminal description

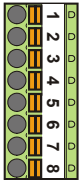
Pin	Designation	Function	Data	
	1	AE1+	+ input of analog input AE1 resolution: <ul style="list-style-type: none"> SEA 5001: 10 bit + sign REA 5001 and XEA 5001: 15 bit + sign 	Reference: Pin 3 $U_1 = \pm 10 \text{ V}$ $R_{\text{int}} = 40 \text{ k}\Omega$ $U_{1\text{max}}$ against pin 3 = 30 V $U_{1\text{max}}$ against protective ground = 15 V $U_{1\text{max}}$ against AGND = 30 V
	2	AE1 shunt	Current input; shunt connection pin 2 is to be bridged with pin 1.	Reference: Pin 3 $I_1 = \pm 20 \text{ mA}$ $R_{\text{int}} = 510 \Omega$
	3	AE1-	Inverted input of analog input AE1	$U_{1\text{max}}$ against pin 1 = 30 V $U_{1\text{max}}$ against protective ground = 15 V $U_{1\text{max}}$ against AGND = 30 V
	4	AE2+	+ input of the analog input AE2; Resolution: <ul style="list-style-type: none"> SEA 5001, XEA 5001: 10 bit + sign REA 5001: 15 bit + sign 	Reference: Pin 5 $U_1 = \pm 10 \text{ V}$ $R_{\text{int}} = 40 \text{ k}\Omega$ $U_{1\text{max}}$ against pin 5 = 30 V $U_{1\text{max}}$ against protective ground = 15 V $U_{1\text{max}}$ against AGND = 30 V
	5	AE2-	Inverted input of analog input AE2	$U_{1\text{max}}$ against protective ground = 15 V $U_{1\text{max}}$ against AGND = 30 V
	6	AA1	Analog output 1	Reference: Pin 8 $I_{2\text{max}} = 10 \text{ mA}$ $R_{\text{int}} = 20 \Omega$ Resolution:
	7	AA2	Analog output 2	<ul style="list-style-type: none"> MDS 5000: 10 bit + sign MDS 5000A, SDS 5000, SDS 5000A: 11 bit + sign
	8	AGND	Reference ground for analog signals	—

Maximum conductor cross-section

Connection type	Maximum conductor cross-section [mm ²]
Rigid	1.5
Flexible	1.5
Flexible with cable end, without plastic sleeve	1.5
Flexible with cable end, with plastic sleeve	0.5
2 leads with the same cross-section with double cable end	—

Terminal description X101 – SEA 5001, REA 5001, XEA 5001

General specification

Maximum cable length	30 m, shielded
----------------------	----------------

Terminal description

Pin	Designation	Function	Data	
	9	GND 18 V	Reference ground for pin 19	
	10	DGND	Reference ground for pins 11 to 18	
	11	BE1	Binary input	High level: 12 – 30 V Low level: 0 – 8 V $U_{1max} = 30 V$ $I_{1max} = 16 mA$ at U_{1max}
	12	BE2		
	13	BE3 ^{a)}		
	14	BE4 ^{a)}		
	15	BE5 ^{a)}		
	16	BA1	Binary output	$I_{2max} = 50 mA$ at 45° C, 40 mA at 55° C
	17	BA2		
18	24 V-In	24 vdc power supply • for XEA 5001 and • for binary outputs for SEA 5001 and REA 5001	Input range: 18 – 28.8 V	
19	18 V-Out	Auxiliary voltage 18 V	$U_2 = 16 – 18 V$ $I_{2max} = 50 mA$	

a) BE3, BE4 and BE5 can be used as an encoder input. Also note section 5.13.4 BE encoder and BA encoder simulation. On the REA 5001, these inputs can be switched by the sliding switch S0, S1 and S2 on the TTL level.

Maximum conductor cross-section

Connection type	Maximum conductor cross-section [mm ²]
Rigid	1.5
Flexible	1.5
Flexible with cable end, without plastic sleeve	1.5
Flexible with cable end, with plastic sleeve	0.5
2 leads with the same cross-section with double cable end	—

TTL/HTL switchover REA 5001

Switch	TTL/HTL conversion
S0	BE3
S1	BE4
S2	BE5

The identification of the switches and the assignment of the switch positions to the function (HTL/TTL) are shown on the PCB cover of the REA 5001.

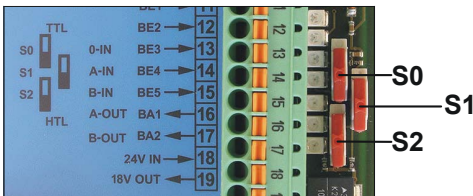
REA 5001

Terminal description X102 – XEA 5001
NOTICE
Machine movement by unexpected reference value

The inverter detects a reference value setting of +5V for an unconnected analog input.

- ▶ Always operate the inverter with a connected analog input.

General specification

Maximum cable length	30 m, shielded
----------------------	----------------

Terminal description

Pin	Designation	Function	Data
	1	AE3+	+ input of analog input AE3 Differential input voltage resolution: 10 bit + sign
	2	AE3-	Inverted input of analog input AE3

Maximum conductor cross-section

Connection type	Maximum conductor cross-section [mm ²]
Rigid	1.5
Flexible	1.5
Flexible with cable end, without plastic sleeve	1.5
Flexible with cable end, with plastic sleeve	0.5
2 leads with the same cross-section with double cable end	—

Terminal description X103 A – XEA 5001

General specification	
Maximum cable length	30 m, shielded

Terminal description

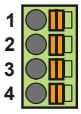
Pin	Designation	Function	Data
	1	BA3	Binary output $I_{2max} = 50 \text{ mA}$
	2	BA4	
	3	BA5	
	4	BA6	

Maximum conductor cross-section

Connection type	Maximum conductor cross-section [mm ²]
Rigid	1,5
Flexible	1,5
Flexible with cable end, without plastic sleeve	1,5
Flexible with cable end, with plastic sleeve	0,75
2 leads with the same cross-section with double cable end	—



Information

When the 24 V power fails, binary inputs BE6 to BE13 have signal status 0 (regardless of the physical signal state).

Terminal description X103 B – XEA 5001

General specification	
Maximum cable length	30 m, shielded

Terminal description

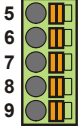
Pin	Designation	Function	Data
	5	BA7	Binary output
	6	BA8	
	7	BA9	
	8	BA10	
9	BE6	Binary input	Reference: Pin 10 of terminal X101 High level: 12 – 30 V Low level: 0 – 8 V $U_{1max} = 30\text{ V}$ $I_{1max} = 3\text{ mA at } U_{1max}$

Maximum conductor cross-section

Connection type	Maximum conductor cross-section [mm ²]
Rigid	1,5
Flexible	1,5
Flexible with cable end, without plastic sleeve	1,5
Flexible with cable end, with plastic sleeve	0,75
2 leads with the same cross-section with double cable end	—

Terminal description X103 C – XEA 5001

General specification	
Maximum cable length	30 m, shielded

Terminal description

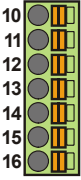
Pin	Designation	Function	Data
	10	BE7	Binary input
	11	BE8	
	12	BE9	
	13	BE10	
	14	BE11	
	15	BE12	
	16	BE13	
			Reference: Pin 10 of terminal X101 High level: 12 – 30 V Low level: 0 – 8 V $U_{1max} = 30\text{ V}$ $I_{1max} = 3\text{ mA at } U_{1max}$

Maximum conductor cross-section

Connection type	Maximum conductor cross-section [mm ²]
Rigid	1,5
Flexible	1,5
Flexible with cable end, without plastic sleeve	1,5
Flexible with cable end, with plastic sleeve	0,75
2 leads with the same cross-section with double cable end	—

Examples of connection

Potentiometer

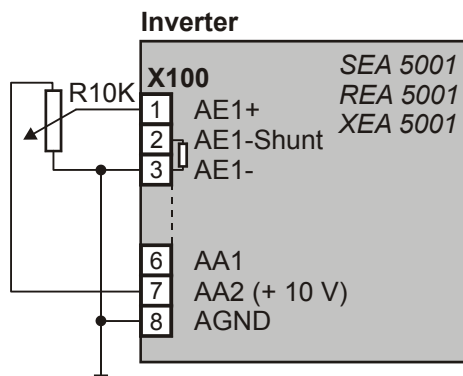

Current (0 - 20 mA, 4 - 20 mA)

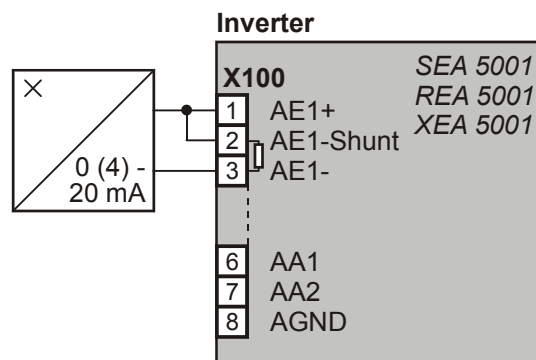

Voltage (max. ± 10 V)

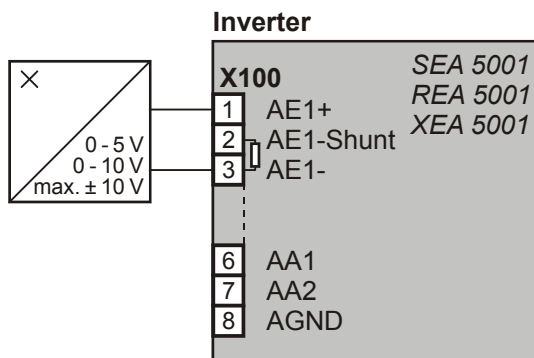

Analog output voltage

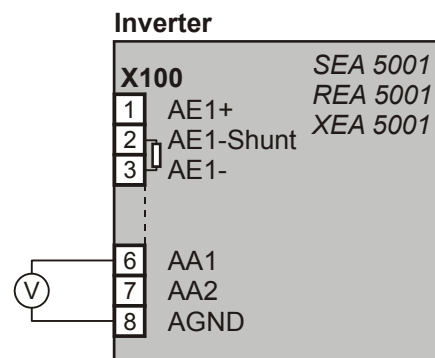

5.13 Encoder



Information

Remember that the encoder interfaces can usually evaluate or simulate several systems (e.g., EnDat and incremental encoder). In the parameters enter the particular system that you are connecting to an interface. Please consult the inverter operating manual in this case.

5.13.1 X4

NOTICE

Danger of encoder destruction!

- ▶ X4 may not be connected or disconnected when the device is on!

General specification

U_2	5–16 V, see the encoder supply table below
I_{2max}	X4: 250 mA Total of X4, X120 and X140: 500 mA
I_{2min}	≤ HW 190: 30 mA; ≥ HW 200: 13 mA
Maximum cable length	100 m

Specification for EnDat 2.1

Encoder type	Single and Multiturn, not suitable for linear measuring devices
Switching frequency	2 MHz
Evaluation	Digital signals only; starting with HW 200 and firmware V 5.6-H, analog signals are tolerated on pins 1, 3, 9 and 11 (compatible with X140).

Specification for EnDat 2.2

Encoder type	Single and Multiturn, not suitable for linear measuring devices
Switching frequency	4 MHz
Evaluation	Digital signals only; starting with HW 200 and firmware V 5.6-H, analog signals are tolerated on pins 1, 3, 9 and 11 (compatible with X140).

SSI specification

Switching frequency	250 kHz
Sampling rate	250 μ s Not permitted as motor encoder in servo mode

SSI specification	
Code	Binary or Gray
Encoder type and format	Multiturn: 24 or 25 bits Single turn: 13 bits short or 13 bits tree (13 bits of data in a 25-bit telegram)
Transfer	Double transmission, can be switched off

Specification for incremental signals	
Encoder type	Only TTL and HTL encoders with N channel may be connected to X4. Encoders without N channel generate a fault when the device starts. If the use of an encoder without N channel is required, the encoder must be connected to X120. Observe the terminal description X120 for incremental signals for proper connection, see section 5.13.2 X120.
f_{\max}	Evaluation: ≤ 1 MHz Simulation: < 250 kHz
Signal level	TTL and HTL



Calculation example – limit frequency f_{\max}

... for an encoder with 2,048 pulses per revolution:

3,000 revolutions per minute (equivalent to 50 revolutions per second) * 2,048 pulses per revolution
 = 102,400 pulses per second
 = 102.4 kHz

Encoder supply

U_2	Through	Remarks
5 V (unregulated)		Pin 12 (sense) not used
5 V (controlled at cable end)	Encoder sense line connected to pin 12 (sense)	STÖBER synchronous servo motors EnDat 2.1/2.2 (standard)
5 V (controlled at X4)	Pin 12 (sense) bridged with pin 4 (UB+)	STÖBER asynchronous motors TTL (for customer-specific solutions), without cable compensation
15 – 16 V	Pin 12 (sense) bridged with pin 2 (GND)	STÖBER asynchronous motors HTL encoder: Bridge created in the cable plug that is connected to X4. SSI encoder: Bridge for UB+ is created in the bracket flange socket.

Terminal description X4 – EnDat and SSI encoders

Pin	Designation	Function	
Socket	1	—	
	2	GND	Reference for encoder power on pin 4
	3	—	
	4	U ₂	Encoder power
	5	DATA+	Differential input for DATA
	6	—	
	7	—	
	8	CLK+	Differential input for CLOCK
	9	—	
	10	—	
	11	—	
	12	Sense	Sensor lead for power supply to settle the encoder power
	13	DATA-	Inverse, differential input for DATA
	14	—	
	15	CLK-	Inverse, differential input for CLOCK

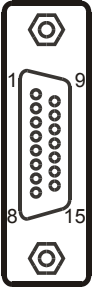

Terminal description X4 for HTL encoder

Pin	Designation	Function, data	
Socket	1	B+	Differential input for B-track
	2	GND	Reference for encoder power on pin 4
	3	N+	Differential input for N-track
	4	U ₂	Encoder power
	5	—	
	6	A+	Differential input for A-track
	7	—	
	8	—	
	9	B-	Inverse, differential input for B-track
	10	N-	Inverse, differential input for N-track
	11	A-	Inverse, differential input for A-track
	12	Sense	Sensor lead for power supply to settle the encoder power
	13	—	
	14	—	
	15	—	

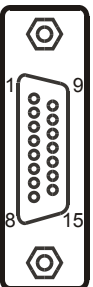

Terminal description X4 for TTL encoder

Pin	Designation	Function, data	
Socket	1	—	
	2	GND	Reference for encoder supply to pin 4
	3	—	—
	4	U ₂	Encoder supply
	5	B+	Differential input for B channel
	6	—	—
	7	N+	Differential input for N channel
	8	A+	Differential input for A channel
	9	—	—
	10	—	—
	11	—	—
	12	Sense	Sensor line for the supply voltage to adjust the encoder supply
	13	B-	Inverse, differential input for B channel
	14	N-	Inverse, differential input for N channel
	15	A-	Inverse, differential input for A channel

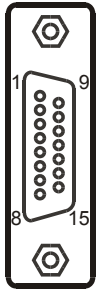

5.13.2 X120

Prerequisite for using interface X120:

- REA 5001 or
- XEA 5001



Information

Interface X120 is a double interface on option board XEA 5001. The double interface makes it possible to distribute encoder signals to other inverters without a great amount of wiring work. This is why the two sub D connections have the same allocation.

General specification	
U_2	18 V, see encoder supply
I_{2max}	250 mA, sum X4, X120 and X140: 500 mA
Maximum cable length	50 m
Maximum number of subscribers	1 master and 31 subscribers
Terminating resistor	120 Ω

Specification SSI (evaluation and simulation)	
Cycle frequency (SSI master)	592 kHz (motor encoder) or 250 kHz (position encoder)
Code	Binary or Gray
Encoder type	Multiturn: 24 or 25 bits Single turn: 13 bit short or 13 bit Tannenbaum
Transfer	Double transmission, can be switched off

Specification incremental and stepper motor signals (evaluation and simulation)	
f_{max}	Evaluation: ≤ 1 MHz Simulation: < 250 kHz
Signal level	TTL



Calculation example – limit frequency f_{max}

... for an encoder with 2,048 pulses per revolution:

3,000 revolutions per minute (equivalent to 50 revolutions per second) * 2,048 pulses per revolution
 = 102,400 pulses per second
 = 102.4 kHz

Encoder supply

Encoder supply	Bridge
Pin 8 (U ₂)	Pin 1 (GND-Enc) to pin 9 (GND)
External	Pin 1 (GND-Enc) to GND of external supply

Terminal description X120 for SSI encoder

Pin	Designation	Function	
Connector 	1	GND-ENC	Reference potential for pin 4 to pin 7
	2	—	—
	3	—	—
	4	CLK-	Inverse differential input/output for CLOCK
	5	CLK+	Differential input/output for CLOCK
	6	DATA+	Differential input/output for DATA
	7	DATA-	Inverse differential input/output for DATA
	8	U ₂	Encoder supply
	9	GND	Reference for pin 8



Information

Remember that all SSI slaves must be switched on/off simultaneously (24 V on X11 and X101.18). Switching individual stations during operation will cause other stations to malfunction.

Terminal description of X120 for incremental signals

Pin	Designation	Function	
Connector 	1	GND-ENC	Reference potential for pin 2 to pin 7
	2	N+	Differential input/output for the N channel
	3	N-	Inverse differential input/output for the N channel
	4	A-	Inverse differential input/output for the A channel
	5	A+	Differential input/output for the A channel
	6	B+	Differential input/output for the B channel
	7	B-	Inverse differential input/output for the B channel
	8	U ₂	Encoder supply
	9	GND	Reference for pin 8

Terminal description of X120 for stepper motor signals

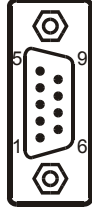
Pin	Designation	Function	
Connector 	1	GND-ENC	Reference potential for pin 2 to pin 7
	2	—	—
	3	—	—
	4	Imp-	Inverse differential input/output for pulses
	5	Imp+	Differential input/output for pulses
	6	Direction+	Differential input/output for the direction
	7	Direction-	Inverse differential input/output for the direction
	8	U ₂	Encoder supply
	9	GND	Reference for pin 8



Connection – topology

Only linear topology is permitted when two or more stations are coupled via interface X120. The signal lines must be terminated with resistors for the stations at either end of the coupling. The terminating resistors can be switched through via switches S3, S4 and S5 on accessory parts XEA 5001 and REA 5001.

Switch	TTL Encoder	SSI Encoder
S3	Zero	—
S4	A	CLK
S5	B	DATA

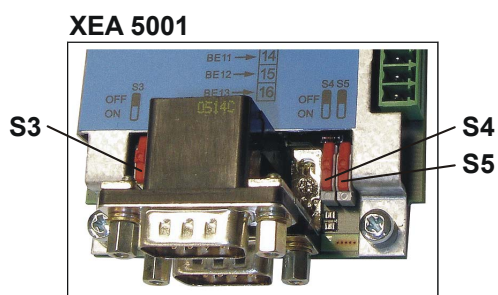

Please note that the switches are installed in different positions on the REA 5001 and XEA 5001 accessories. Identification of the switches and assignment of the switch positions to the function (switched on/switched off terminal resistance) are shown on the PCB cover.

5.13.3 X140

Prerequisite for using interface X140:

- REA 5001

Resolver specification (evaluation)	
U_2	-10 V ... +10 V
I_2	80 mA
f_2	7 – 9 kHz
P_{\max}	0.8 W
Transfer ratio	$0,5 \pm 5 \%$
Number of poles	2, 4 and 6
Phase shift	$\pm 20 \text{ el.}^\circ$
Maximum cable length	100 m

Specification EnDat 2.1 sin/cos (evaluation)	
U_2	5 – 16 V, see below table encoder supply EnDat
$I_{2\max}$	250 mA, total of X4, X120 and X140 (EnDat): 500 mA
$I_{2\min}$	30 mA
f_{\max}	225 kHz
Encoder type	Single and Multiturn, not suitable for linear measuring devices
Maximum cable length	100 m



Calculation example – limit frequency f_{\max}

... for an encoder with 2,048 pulses per revolution:

3,000 revolutions per minute (equivalent to 50 revolutions per second) * 2,048 pulses per revolution

= 102,400 pulses per second

= 102.4 kHz

Encoder supply EnDat 2.1

U_2	Through	Remarks
5 V (unregulated)		Pin 12 (sense) not used
5 V (controlled at cable end)	Encoder sense line connected to pin 12 (sense)	STÖBER servo motors EnDat 2.1
5 V (controlled at X4)	Pin 12 (sense) bridged with pin 4 (UB+)	TTL (for customer-specific solutions)



Information

Note that the resolver interface at X140 is also used if a SDS 4000 is replaced where a motor with resolver at X40 was operated.

In this case, you can continue to use the previously used encoder cable. The connection of the motor temperature sensor is carried in this cable. For this reason, observe the Chapter 5.8.

Terminal description X140 resolver (REA 5001)

Pin ^{a)}	Designation	Function	
Socket	1	Sin+	Sin input
	2	GND	Reference to pin 6
	3	Cos+	Cos input
	4	—	—
	5	—	—
	6	ErregungResolv	Resolver excitation signal
	7	1TP1/K1	Motor temperature sensor connection, if carried by the encoder cable; output at pin 1 of X141.
	8	—	—
	9	Sin-	Sin input (inverse)
	10	—	—
	11	Cos-	Cos input (inverse)
	12	—	—
	13	—	—
	14	1TP2/K2	Motor temperature sensor connection, if carried by the encoder cable; output at pin 2 of X141.
	15	—	—

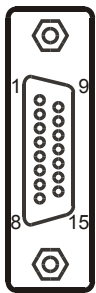

a) View of sub-D

Terminal description of resolver adapter (REA 5001)

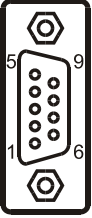
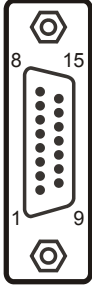
Pin ^{a)}	Designation	Function	Pin ^{b)}
Socket 	1	—	—
	2	1TP1/K1	7
	3	Sin-	9
	4	Cos-	11
	5	GND	2
	6	1TP2/K2	14
	7	Sin+	1
	8	Cos+	3
	9	ErregungResolv	6
			Connector 

a) view of sub-D 9-pole for the connection of the SDS 4000-compatible resolver cable

b) view of sub-D 15-pole for the connection to the SDS 5000, terminal X140 (REA 5001)

**Information**

Note that the EnDat interface at X140 is used if a SDS 4000 is replaced and a motor with an absolute encoder at X41 was operated.

In this case, you can continue to use the previously used encoder cable. The connection of the motor temperature sensor is carried in this cable. For this reason, observe the Chapter 5.8.

Terminal description X140 EnDat (REA 5001)

Pin ^{a)}	Designation	Function	
Socket	1	Sin+	Sin input
	2	GND	Reference for encoder supply to pin 4
	3	Cos+	Cos input
	4	U ₂	Encoder supply
	5	DATA+	Differential input for DATA
	6	—	—
	7	1TP1/K1	Connection motor temperature sensor is output to X141, pin 1 if carried by the encoder cable
	8	CLK+	Differential input for C:PCL
	9	Sin-	Inverse sin input
	10	—	—
	11	Cos-	Inverse cos input
	12	Sense	Sense signals for voltage control
	13	DATA-	Inverse differential input for DATA
	14	1TP2/K2	Connection motor temperature sensor is output to X141, pin 2 if carried by the encoder cable
	15	CLK-	Inverse differential input for CLOCK

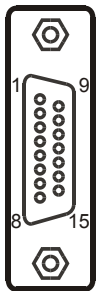

a) View of sub-D

5.13.4 BE encoder and BA encoder simulation

Prerequisite for being able to evaluate or simulate an encoder on the binary interfaces:

- SEA 5001 or
- REA 5001 or
- XEA 5001

To evaluate single-ended incremental encoder or stepper motor signals, use binary inputs BE3, BE4 and BE5.

If you would like to simulate them, use outputs BA1 and BA2.

Hall encoders are connected to binary inputs BE1, BE2 and BE3.

General specification	
Maximum cable length	30 m
Signal level	HTL for SEA 5001 and XEA 5001 TTL/HTL switchable for REA 5001

Evaluation – incremental and stepper motor signals

	HTL	TTL
High level	12 – 30 V	2 – 6 V
Low level	0 – 8 V	0 – 0.8 V
$U_{1\max}$	30 V	6 V
$I_{1\max}$	16 mA	13 mA
f_{\max}	100 kHz	

Simulation – incremental and stepper motor signals

$I_{2\max}$	50 mA at 45° C, 40 mA at 55° C
Eff. update rate	4 kHz
f_{\max}	250 kHz
Extrapolation frequency	1 MHz

Calculation example – limit frequency f_{\max}

... for an encoder with 2,048 pulses per revolution:

3,000 revolutions per minute (equivalent to 50 revolutions per second) * 2,048 pulses per revolution

= 102,400 pulses per second

= 102.4 kHz

Terminal description X101 incremental encoder and stepper motor signals

Pin	Designation	Function	Data
9	GND 18 V	Reference ground for pin 19	—
10	DGND	Reference ground for pins 11 to 18	—
11	BE1	—	—
12	BE2	—	
13	BE3	Evaluation: Incremental encoder: N Stepper motor signals: —	
14	BE4	Evaluation: Incremental encoder: A Stepper motor signals: freq.	
15	BE5	Evaluation: Incremental encoder: B Stepper motor signals: direction	
16	BA1	Simulation Incremental encoder: A Stepper motor signals: freq.	—
17	BA2	Simulation Incremental encoder: B Stepper motor signals: direction	
18	24 V-In	24 V power - For XEA 5001 and - For binary outputs with SEA 5001 and RE A 5001	Input range: 18 – 28.8 V
19	18 V-Out	Auxiliary voltage 18 V	$U_2 = 16 - 18 \text{ V}$ $I_{2\text{max}} = 50 \text{ mA}$

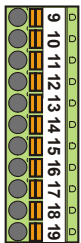

TTL/HTL switchover REA 5001

Switch	TTL/HTL conversion
S0	BE3
S1	BE4
S2	BE5

The identification of the switches and the assignment of the switch positions to the function (HTL/TTL) are shown on the PCB cover of the REA 5001.

REA 5001

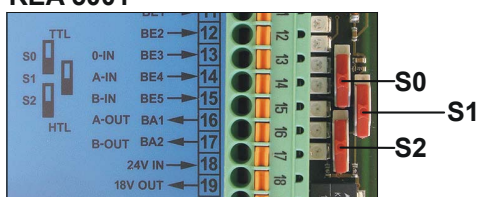

5.14 Fieldbus

5.14.1 X200: CANopen

Prerequisite for the CANopen link:

- CAN 5000



Information

Please see the supplementary documentation of CANopen (see section 1.2 Further documentation)!

Terminal description X200

Pin	Designation	Function	
Plug	1	—	
	2	CAN-low	CAN-low line
	3	GND	Signal Ground
	4	—	—
	5	—	—
	6	CAN-low	CAN-low line connected internally with pin 2
	7	CAN-high	CAN-high line
	8	—	—
	9	CAN-high	CAN-high line connected internally with pin 7

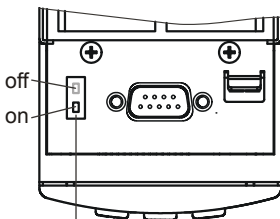
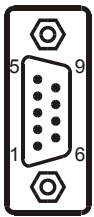

Internal terminating resistance 120 Ω can be activated

5.14.2 X200: PROFIBUS

Prerequisite for the PROFIBUS link:

- DP 5000



Information

Please see the supplementary documentation of PROFIBUS DP (see section 1.2 Further documentation)!

Terminal description X200

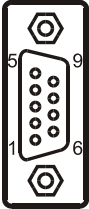
Pin	Designation	Function	
Socket 	1	—	
	2	—	
	3	B	RxD / TxD-P (send/receive data +)
	4	RTS	Direction control for repeater +
	5	GND	Ground to + 5 V
	6	+5 V	Power for terminating resistors
	7	—	—
	8	A	RxD / TxD-N (send/receive data -)
	9	—	—

5.14.3 X200, X201: EtherCAT

Prerequisite for the EtherCAT link:

- ECS 5000



Information

Please see the supplementary documentation of EtherCAT (see section 1.2 Further documentation)!

X200 and X201 terminal description

Pin	Designation	Function	
	1	TxDa+ EtherCAT communication	
	2	TxDa-	
	3	RecvDa+	
	4	—	—
	5	—	—
	6	RecvDa- EtherCAT communication	
	7	—	—
	8	—	—

Cable specification

STÖBER provides ready-made cables for the EtherCAT connection. These cables must be used to ensure proper functionality.

It is also possible to use cables with the following specification:

Plug wiring	Patch or crossover
Quality	CAT5e
Shielding	SFTP or PIMF

5.14.4 X200, X201: PROFINET

Requirement for the die PROFINET connection:

- PN 5000



Information

Observe the PROFINET operating manual (see section 1.2 Further documentation)!

X200 and X201 terminal description

The terminal configuration is determined by T 568-B.

Pin	Designation	Function
1	TxData +	PROFINET communication
2	TxData -	
3	RecvData +	
4	—	Connect via RC-link with housing
5	—	
6	RecvData -	PROFINET communication
7	—	Connect via RC-link with housing
8	—	

Observe the PROFINET installation guideline for the cable specification (PROFINET Order No. 8.071, identification: T2-08-0001); you can obtain the document at www.profibus.com.

5.15 X3A, X3B: PC, IGB

You can implement the functions of the IGB (Integrated Bus) with interface X3 located on the front of the inverter:

- Direct connection to the PC
- IGB Motionbus
- remote maintenance

Observe the operating manual SDS 5000, see section 1.2 Further documentation for setting up communication.

Terminal description X3A and X3B

Pin	Designation	Function
1	TxDat+	Ethernet communication
2	TxDat-	
3	RecvDat+	
4	—	Not used
5	—	
6	RecvDat-	Ethernet communication
7	—	
8	—	Not used

Cable specification

STÖBER provides ready-made cables for

- direct connection PC - inverter and
- to set up the Integrated Bus.

These cables must be used to ensure proper functionality. Note also section 7 Accessories.

It is also possible to use cables with the following specification:

Plug wiring	Patch or crossover
Quality	CAT5e
Shielding	SFTP or PIMF

5.16 Cables



Information

To ensure proper functionality of the drive we recommend using cables from STÖBER that are coordinated with the system. In case of use of unsuitable connection cables, we reserve the right to reject claims under the warranty.

5.16.1 Power cable

Synchronous servo motors of series ED/EK and EZ are equipped with circular plugs as standard and can be connected to inverters with the following power cables (the color specifications relate to the connection strands and are only significant for the motor-internal wiring).

Power cable – connector size con.15

Bracket flange socket – motor	Pin	Signal	Motor-internal wire colors
	A	1U1	BK
	B	1V1	BU
	C	1W1	RD
	1	1TP1/1K1	BK/BN
	2	1TP2/1K2	WH/WH
	3	1BD1	RD
	4	1BD2	BK
	⏚	PE	GNYE
	Housing	Shield	

Power cable – connector size con.23

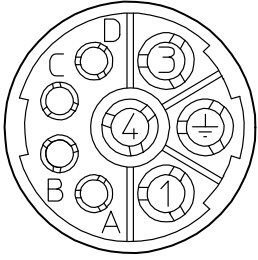
Bracket flange socket – motor	Pin	Signal	Motor-internal wire colors
	A	1BD1	RD
	B	1BD2	BK
	C	1TP1/1K1	BK/BN
	D	1TP2/1K2	WH/WH
	1	1U1	BK
	3	1V1	RD
	4	1W1	BU
	\perp	PE	GNYE
	Housing	Shield	

Power cable – connector sizes con.40, con.58

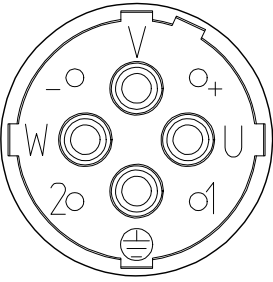
Bracket flange socket – motor	Pin	Signal	Motor-internal wire colors
	U	1U1	BK
	V	1V1	BU
	W	1W1	RD
	+	1BD1	RD
	-	1BD2	BK
	1	1TP1/1K1	BK/BN
	2	1TP2/1K2	WH/WH
	\perp	PE	GNYE
	Housing	Shield	

5.16.2 Encoder Cables

STÖBER motors are equipped with encoder systems as standard.

Depending on the respective motor types, different encoder systems and associated plug connectors are used.

The following section describes the individual encoder systems, plug connectors and signal assignments.

5.16.2.1 Encoder EnDat and SSI

Digital absolute encoder EnDat 2.1 and EnDat 2.2 of series ECI, EQI, ECN or EQN can be combined with STÖBER motors of series ED/EK and EZ. SSI encoders can also be connected to STÖBER asynchronous motors.

The suitable encoder cables are described below.

Encoder cable – plug connector con.15

Cable with plug connector con.15 in combination with EnDat encoders can be connected to EZ motors.

The voltage supply is buffered for the inductive EnDat 2.2 encoders "EBI 1135" and "EBI 135" with multiturn function. In this case, pin 2 and pin 3 are assigned to the backup battery U_{2BAT} . Note that the encoder cable must not be connected to X4 of the inverter but to the Absolute Encoder Support (AES) for these encoders.

Motor	Signal		Wire colors		Sub-D connector (X4)
	Angle flange socket	Pin	Motor-internal	Encoder	
	1	CLK+	VT	YE	8
	2	Sense/ $U_{2BAT} +$ ^{a)}	BU	PK	12
	3	$U_{2BAT}-$	WH	GY	3
	4	—	—	—	—
	5	DAT-	PK	BN	13
	6	DAT+	GY	WH	5
	7	—	—	—	—
	8	CLK-	YE	GN	15
	9	—	—	—	—
	10	GND	WHGN	BU	2
	11	—	—	—	—
	12	U_2	BNGN	RD	4
	Housing	Shield			

a) buffer battery U_{2BAT} (= 3.6 – 5.25 V_{DC}): only relevant for EBI encoder in conjunction with the "Absolute Encoder Support (AES)" option.

Encoder cable – plug connector con.17

The voltage supply is buffered for the inductive EnDat 2.2 encoders "EBI 1135" and "EBI 135" with multiturn function. In this case, pin 2 and pin 3 are assigned to the backup battery U_{2BAT} . Note that the encoder cable must not be connected to X4 of the inverter but to the Absolute Encoder Support (AES) for these encoders.

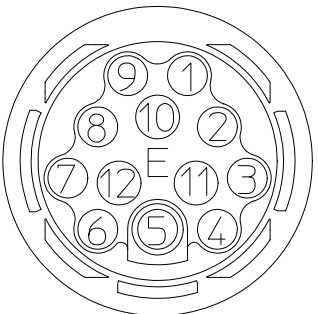
Motor	Signal		Wire colors		Sub-D connector (X4) Pin		
	Angle flange socket	Pin	Motor-internal	Encoder			
		1	CLK+	VT	YE	8	
		2	Sense/ U_{2BAT+} ^{a)}	BU	PK		12
		3	U_{2BAT-}	WH	GY		3
		4	—	—	—		—
		5	DAT-	PK	BN		13
		6	DAT+	GY	WH		5
		7	—	—	—		—
		8	CLK-	YE	GN		15
		9	—	—	—		—
		10	GND	WHGN	BU		2
		11	—	—	—		—
		12	U_2	BNGN	RD		4
		Housing	Shield				

a) buffer battery U_{2BAT} (= 3.6 – 5.25 V_{DC}): only relevant for EBI encoder in conjunction with the "Absolute Encoder Support (AES)" option.



Encoder cable – plug connector con.23

Cable with plug connector con.23 in combination with EnDat 2.1 and EnDat 2.2 encoders can be connected to synchronous servo motors ED/EK; connect these with asynchronous motors in combination with SSI encoders.

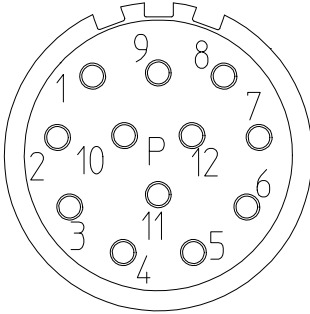
Motor	Signal		Wire colors		Sub-D connector (X4) Pin
	Angle flange socket	Pin	Motor-internal	Encoder	
	1	CLK+	VT	YE	8
	2	Sense	BNGN	PK	12
	3	—	—	—	—
	4	—	—	—	—
	5	DAT-	PK	BN	13
	6	DAT+	GY	WH	5
	7	—	—	—	—
	8	CLK-	YE	GN	15
	9	—	—	—	—
	10	GND	WHGN	BU	2
	11	—	—	—	—
	12	U ₂	BNGN	RD	4
	Housing	Shield			

5.16.2.2 Encoder EnDat Sin/Cos

Absolute encoder EnDat 2.1 Sin/Cos of series ECI, EQI, ECN or EQN can be combined with STÖBER motors of series ED/EK and EZ.

The suitable encoder cables are described below.

Encoder cable – plug connector con.15

Cable with plug connector con.15 in combination with EnDat 2.1 Sin/Cos encoders can be connected to EZ motors.

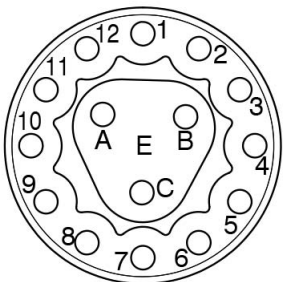
Motor	Signal		Wire colors		Sub-D connector (X140)
	Angle flange socket	Pin	Motor-internal	Encoder	
	1	Sense+	BU	GNRD	12
	2	Sense-	WH	GNBK	10
	3	U ₂	BNGN	BNRD	4
	4	CLK+	VT	WHBK	8
	5	CLK-	YE	WHYE	15
	6	GND	WHGN	BNBU	2
	7	B+ (Sin+)	BUBK	RD	9
	8	B- (Sin-)	RDBK	OG	1
	9	DAT+	GY	GY	5
	10	A+ (Cos+)	GNBK	GN	11
	11	A- (Cos-)	YEBK	YE	3
	12	DAT-	PK	BU	13
	A	—	—	—	—
	B	—	—	—	—
	C	—	—	—	—
Housing	Shield				



Encoder cable – plug connector con.17

Cable with plug connector con.17 in combination with EnDat 2.1 Sin/Cos encoders can be connected to EZ motors.

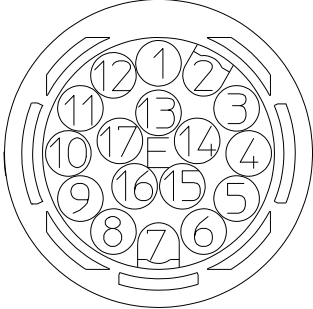
Motor	Signal		Wire colors		Sub-D connector (X140)
	Angle flange socket	Pin	Motor-internal	Encoder	
	1	Sense+	BU	GNRD	12
	2	—	—	—	—
	3	—	—	—	—
	4	Sense-	WH	GNBK	10
	5	—	—	—	—
	6	—	—	—	—
	7	U ₂	BNGN	BNRD	4
	8	CLK+	VT	WHBK	8
	9	CLK-	YE	WHYE	15
	10	GND	WHGN	BNBU	2
	11	—	—	—	—
	12	B+ (Sin+)	BUBK	RD	9
	13	B- (Sin-)	RDBK	OG	1
	14	DAT+	GY	GY	5
	15	A+ (Cos+)	GNBK	GN	11
	16	A- (Cos-)	YEBK	YE	3
	17	DAT-	PK	BU	13
Housing	Shield				

Encoder cable – plug connector con.23

Cable with plug connector con.23 in combination with EnDat 2.1 Sin/Cos encoders can be connected to ED/EK motors.

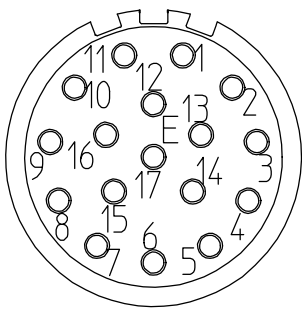
Motor	Signal		Wire colors		Sub-D connector (X140) Pin
	Angle flange socket	Pin	Motor-internal	Encoder	
	1	Sense+	BU	GNRD	12
	2	—	—	—	—
	3	—	—	—	—
	4	Sense-	WH	GNBK	10
	5	—	—	—	—
	6	—	—	—	—
	7	U ₂	BNGN	BNRD	4
	8	CLK+	VT	WHBK	8
	9	CLK-	YE	WHYE	15
	10	GND	WHGN	BNBU	2
	11	—	—	—	—
	12	B+ (Sin+)	BUBK	RD	9
	13	B- (Sin-)	RDBK	OG	1
	14	DAT+	GY	GY	5
	15	A+ (Cos+)	GNBK	GN	11
	16	A- (Cos-)	YEBK	YE	3
	17	DAT-	PK	BU	13
Housing	Shield				



5.16.2.3 Encoder HTL

HTL incremental encoders can be combined with STÖBER motors of series ED/EK or EZ. The suitable encoder cable is described below.

Encoder cable – plug connector con.23

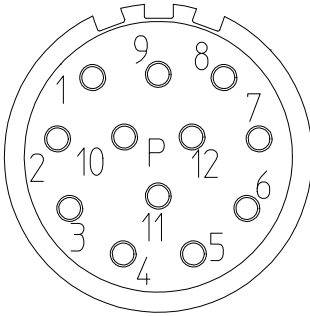
Motor	Signal	Wire colors		Sub-D connector (X4)	
		Angle flange socket	Pin		Motor-internal
	1	B-	PK	YE	9
	2	—	—	—	—
	3	N+	RD	PK	3
	4	N-	BK	GY	10
	5	A+	BN	BN	6
	6	A-	GN	WH	11
	7	—	—	—	—
	8	B+	GY	GN	1
	9	—	—	—	—
	10	GND	WH	BU	2
	11	—	—	—	—
	12	U ₂	BN	RD	4
	Housing	Shield			

5.16.2.4 Resolver

Resolvers can be combined with STÖBER motors of series ED/EK or EZ.

The suitable resolver cables are described below.

Encoder cable – plug connector con.15

Cable with plug connector con.15 in combination with resolvers can be connected to EZ motors.

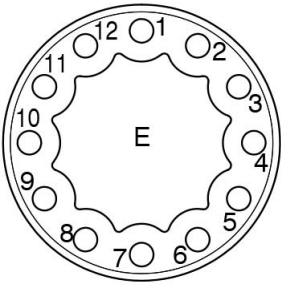
Motor	Signal		Wire colors		Sub-D connector (X140)
	Angle flange socket	Pin	Motor-internal	Encoder	Pin
	1	S3 Cos+	BK	YE	3
	2	S1 Cos-	RD	GN	11
	3	S4 Sin+	BU	WH	1
	4	S2 Sin-	YE	BN	9
	5	—	—	—	Do not connect
	6	—	—	—	Do not connect
	7	R2 Ref+	YEWH	GY	6
	8	R1 Ref-	RDWH	PK	2
	9	—	—	—	—
	10	—	—	—	—
	11	—	—	—	—
	12	—	—	—	—
	Housing	Shield			



Encoder cable – plug connector con.17

Cable with plug connector con.17 in combination with resolvers can be connected to EZ motors.

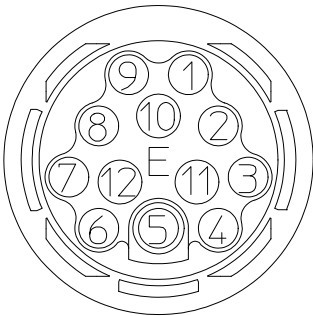
Motor	Signal	Wire colors		Sub-D connector at terminal X140	
		Angle flange socket	Pin		Motor-internal
	1	S3 Cos+	BK	YE	3
	2	S1 Cos-	RD	GN	11
	3	S4 Sin+	BU	WH	1
	4	S2 Sin-	YE	BN	9
	5	—	—	—	Do not connect
	6	—	—	—	Do not connect
	7	R2 Ref+	YEWH	GY	6
	8	R1 Ref-	RDWH	PK	2
	9	—	—	—	—
	10	—	—	—	—
	11	—	—	—	—
	12	—	—	—	—
	Housing	Shield			

Encoder cable – plug connector con.23

Cable with plug connector con.23 in combination with resolvers can only be connected to synchronous servo motors ED/EK.

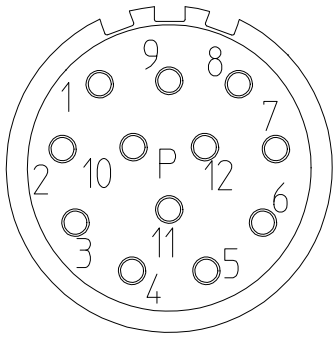
Motor	Signal	Wire colors		Sub-D connector (X140)	
		Angle flange socket	Pin		Motor-internal
	1	S3 Cos+	BK	YE	3
	2	S1 Cos-	RD	GN	11
	3	S4 Sin+	BU	WH	1
	4	S2 Sin-	YE	BN	9
	5	—	—	—	Do not connect
	6	—	—	—	Do not connect
	7	R2 Ref+	YEW H	GY	6
	8	R1 Ref-	RDW H	PK	2
	9	—	—	—	—
	10	—	—	—	—
	11	—	—	—	—
	12	—	—	—	—
	Housing	Shield			

Cable color – key

BK	BLACK	PK	PINK
BN	BROWN	RD	RED
BU	BLUE	VT	VIOLET
GN	GREEN	WH	WHITE
GY	GREY	YE	YELLOW
OG	ORANGE		



6 Examples of connections

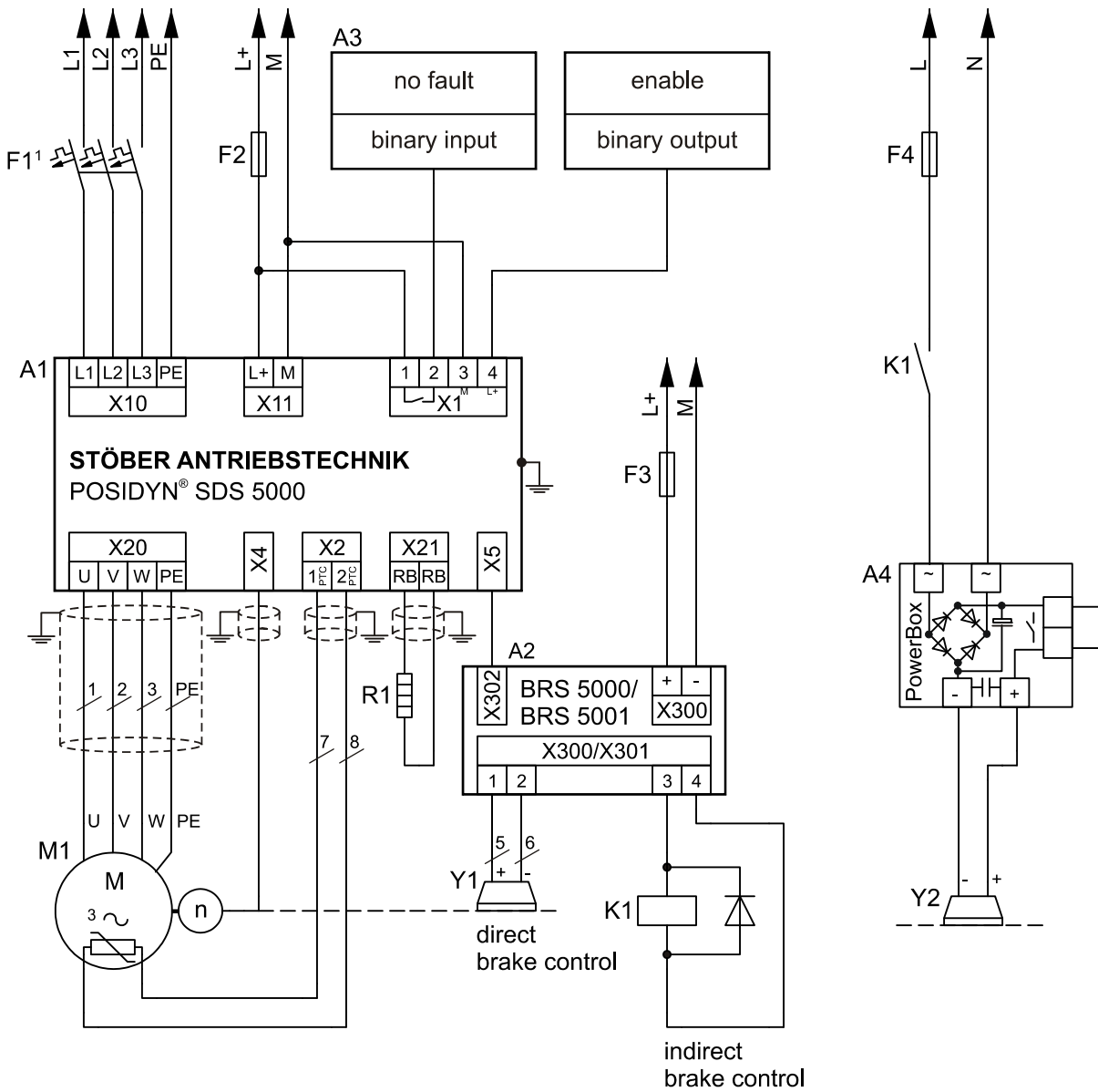

¹ circuit protection tripping characteristics C

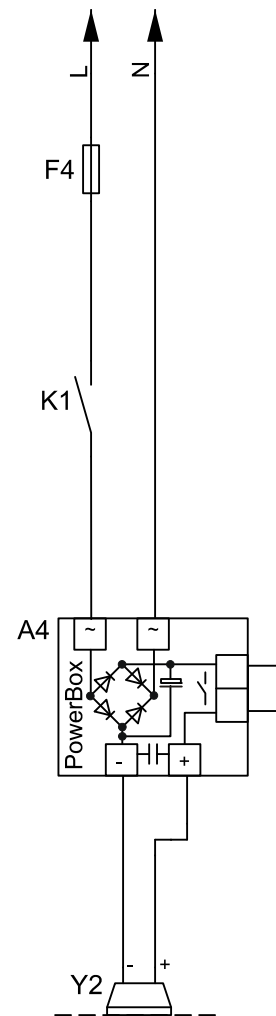

7 Accessories

Inverter	HW status of the inverter	SEA 5001	REA 5001	XEA 5001
SDS 5000A	200 or higher	Yes	Yes	HW status 11 or higher for the accessories
SDS 5000	up to 199	Yes	Yes	HW status 11 or higher for the accessories

I/O terminal module standard SEA 5001

ID no. 49576



Terminals:

- 2 analog inputs
- 2 analog outputs
- 5 binary inputs
- 2 binary outputs

I/O terminal module extended XEA 5001

ID no. 49015

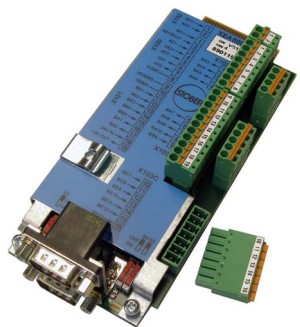

Terminals:

- 3 analog inputs
- 2 analog outputs
- 13 binary inputs
- 10 binary outputs

Encoder:

- TTL incremental encoder (simulation and evaluation)
- Stepper motor signals (simulation and evaluation)
- SSI encoder (simulation and evaluation)

SSI/TTL connection cable X120

ID no. 49482

For connection of the SSI interface X120 to the XEA 5001, 0.3 m.



I/O terminal module resolver REA 5001

ID no. 49854

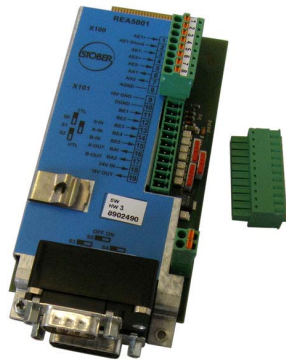

Terminals:

- 2 analog inputs
- 2 analog outputs
- 5 binary inputs
- 2 binary outputs

Encoder:

- Resolver
- EnDat 2.1 Sin/Cos encoder
- TTL incremental encoder (simulation and evaluation)
- SSI encoder (simulation and evaluation)
- Stepper motor signals (simulation and evaluation)

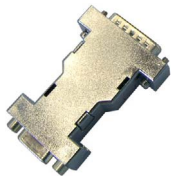

Resolver cables that were connected to an inverter SDS 4000 can be connected via the resolver cable included in the scope of delivery to terminal X140 of REA 5001.



Information

The brake module BRS 5001 is the follow-up model to BRS 5000. The new version is equipped with separate terminals for the connection of a motor holding brake and 24 vdc power supply as well as a screwable shield connection terminal. BRS 5001 requires firmware V 5.6-N or higher.

Brake module BRS 5001

ID no. 56518

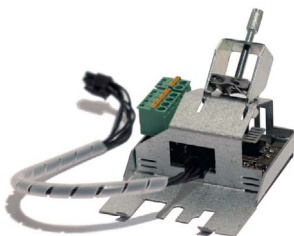

Accessory part for direct control of up to two motor holding brakes (24 V/DC). Attachable on the basic housing. Including connection cable for basic device and shield connection terminal for power cable cross-sections of 1 to 10 mm².

Brake module BRS 5000

ID no. 49853

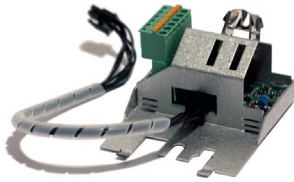

Accessory part for direct control of up to two motor holding brakes (24 V/DC). Attachable on the basic housing. Including connection cable for basic device and shield connection terminal.

EMC shroud EM 5000

ID no. 44959

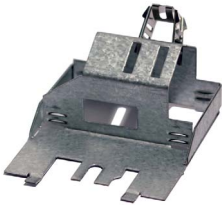

Accessory part for shield connection of the motor line. Attachable on the basic housing. Including shield connection terminal

EMC shroud EM6A3

ID no. 135120

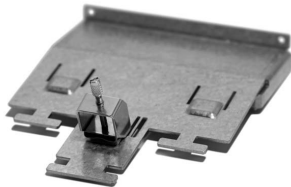

EMC shroud for size 3. Accessory part for shield connection of the motor line. Attachable on the basic housing. Including shield connection terminal for power cable cross-sections of 6 to 25 mm². If necessary you can also connect the cable shield of the braking resistor and DC link connection on the shroud. Additional shield connection terminals are available as accessories for this purpose.

4-way axis switcher POSISwitch AX 5000

ID no. 49578



Enables the operation of up to four servo motors on one inverter.



POSISwitch connection cable

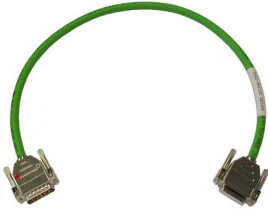

Connection between inverter and POSISwitch AX 5000.

The following versions are available:

ID no. 45405: 0.5 m.

ID no. 45386: 2.5 m.

Absolute Encoder Support AES

ID no. 55452

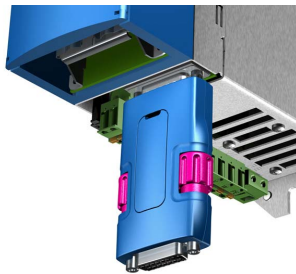

For buffering the power supply when using the inductive Multiturn EnDat 2.2 absolute encoder EBI1135 when the 24 vdc power supply is switched off at the inverter. A battery is included.

Replaceable battery AES

ID no. 55453



Replaceable battery for Absolute Encoder Support AES.

Fieldbus module CANopen DS-301 CAN 5000

ID no. 44574

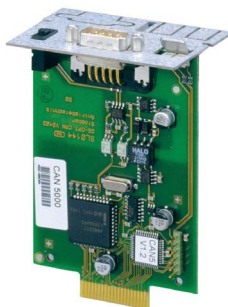

Accessory part for connecting CAN bus.

Fieldbus module PROFIBUS DP-V1 DP 5000

ID no. 44575



Accessory module for connecting PROFIBUS DP-V1.

Fieldbus module EtherCAT ECS 5000

ID no. 49014



Accessory part for connecting EtherCAT (CANopen over EtherCAT).

EtherCAT cable



EtherNet patch cable, CAT5e, yellow.

The following versions are available:

ID no. 49313: approx. 0.2 m.

ID no. 49314: approx. 0.35 m.

Fieldbus module PROFINET PN 5000

ID no. 53893



Accessory part for connecting PROFINET.



ASP 5001 – Safe Torque Off

Available with the standard version.

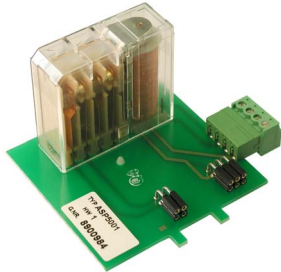

The ASP 5001 may only be installed by STÖBER ANTRIEBSTECHNIK GmbH & Co. KG!

The ASP 5001 must be ordered with the basic device.

IGB connecting cable



To connect the interface X3 A or X3 B on the inverter front for IGB, CAT5e, magenta, connector angled at 45°.

The following versions are available:

ID no. 49855: 0.4 m.

ID no. 49856: 2 m.

PC connecting cable

ID no. 49857



To connect the X3 A or X3 B interface to PC, CAT5e, blue, 5m.

Hi-speed USB 2.0 Ethernet adapter

ID no. 49940



Adapter for connecting Ethernet to a USB connection.

Paramodule



Memory module for configuration and parameters.

The following versions are available:

ID no. 49315:

for SDS 5000 (HW version < 190), 256 kB.

ID no. 55464:

for SDS 5000A (HW version > 200), 1 MB.



Address registers

Always up to date on the internet: www.stober.com (Contact)

- Technical offices for advice and marketing in Germany
- Global presence for advice and marketing in about 25 countries
- Service network Germany
- Service network international
- STÖBER subsidiaries:

Austria

STÖBER ANTRIEBSTECHNIK GmbH
Hauptstraße 41a
4663 Laakirchen
Fon +43 7613 7600-0
Fax +43 7613 7600-2525
E-Mail: office@stoeber.at
www.stoeber.at

USA

STOBER DRIVES INC.
1781 Downing Drive
Maysville, KY 41056
Fon +1 606 7595090
Fax +1 606 7595045
eMail: sales@stober.com
www.stober.com

France

STÖBER S.a.r.l.
131, Chemin du Bac à Traille
Les Portes du Rhône
69300 Caluire et Cuire
Fon +33 4 78989180
Fax +33 4 78985901
eMail: mail@stober.fr
www.stober.fr

Switzerland

STÖBER SCHWEIZ AG
Ruggölzli 2
5453 Remetschwil
Fon +41 56 496 96 50
Fax +41 56 496 96 55
eMail: info@stoeber.ch
www.stoeber.ch

Great Britain

STOBER DRIVES LTD.
Upper Keys Business Village
Keys Park Road, Hednesford
Cannock WS12 2HA
Fon +44 1543 458 858
Fax +44 1543 448 688
E-Mail: mail@stober.co.uk
www.stober.co.uk

Italy

STÖBER TRASMISSIONI S. r. l.
Via Italo Calvino, 7
Palazzina D
20017 Rho (MI)
Fon +39 02 93909-570
Fax +39 02 93909-325
eMail: info@stoeber.it
www.stoeber.it

China

STOBER CHINA
German Centre Beijing
Unit 2010, Landmark Tower 2,
8 North Dongsanhuan Road
Chaoyang District
100004 Beijing
Fon +86 10 65907391
Fax +86 10 65907393
eMail: info@stoeber.cn
www.stoeber.cn

Japan

STOBER Japan
P.O. Box 113-002, 6 chome
15-8, Hon-komagome
Bunkyo-ku
Tokyo
Fon +81 3 5395-6788
Fax +81 3 5395-6799
eMail: mail@stober.co.jp
www.stober.co.jp

Singapore

STOBER Singapore Pte. Ltd.
50 Tagore Lane
#05-06B
Entrepreneur Centre
Singapore 787494
Fon +65 65112912
Fax +65 65112969
E-Mail: info@stober.sg
www.stober.sg



STÖBER ANTRIEBSTECHNIK GmbH & Co. KG

Kieselbronner Str. 12
75177 PFORZHEIM
GERMANY
Tel. +49 7231 582-0
Fax. +49 7231 582-1000
E-Mail: mail@stoeber.de

24/h service hotline +49 180 5 786 323

www.stober.com

Technische Änderungen vorbehalten
Errors and changes excepted
ID 442277.07
03/2015



4 4 2 2 7 7 . 0 7