



Gear racks Operating manual

en-US
04/2024
ID 443392_en.00

Table of contents

1	User information	4
1.1	Storage and transfer.....	4
1.2	Original language.....	4
1.3	Formatting conventions	4
1.4	Terms.....	5
1.5	Supporting documents	5
1.6	Limitation of liability.....	5
1.7	Product names and brands.....	5
1.8	Copyright notice	5
2	Safety notes	6
2.1	Intended use.....	6
2.2	Requirements for personnel.....	6
2.3	Prevention of personal injury	6
2.3.1	Mechanical hazards	6
2.4	Prevention of property damage	7
3	Product description	8
3.1	Basic structure	8
3.2	Type designation	9
3.3	Nameplate	9
3.4	Ambient conditions	10
3.5	Additional documentation.....	10
4	Transport and storage	11
4.1	Storage	11
4.2	Transport	11
5	Installation	12
5.1	Requirements for the connecting structure	12
5.2	Tools	13
5.3	Cleaning agent and solvent	13
5.4	Preparing for installation.....	13
5.5	Installing the first gear rack.....	13
5.6	Installing another gear rack.....	15
5.7	Checking the transition between the gear racks.....	16
5.8	Securing a gear rack with pins.....	17
5.9	Installing the gear unit with pinion.....	18

5.10	Final inspection.....	19
5.11	Ensuring lubrication.....	20
6	Commissioning.....	22
6.1	Before commissioning	22
6.2	During commissioning	22
7	Servicing	23
7.1	Inspection	23
7.2	Cleaning	23
7.3	Remedying faults.....	23
7.3.1	Troubleshooting faults.....	24
7.4	Servicing	24
7.5	Service	24
8	Removal and disposal.....	26
8.1	Removal	26
8.2	Disposal	26

1 User information

This documentation is a part of the product. It applies to products in the standard design according to the corresponding STOBER catalog.

1.1 Storage and transfer

As this documentation contains important information for handling the product safely and efficiently, it must be stored in the immediate vicinity of the product until product disposal and be accessible to qualified personnel at all times.

Also pass on this documentation if the product is transferred or sold to a third party.

1.2 Original language

The original language of this documentation is German; all other language versions are derived from the original language.

1.3 Formatting conventions

Orientation guides in the form of signal words are used to emphasize specific information so that you are able identify it in this documentation quickly.

Safety notes indicate special risks when handling the product and are accompanied by relevant signal words that express the extent of the risk. In addition, warning messages for possible property damage and useful information are also indicated by signal words.

WARNING!

Warning

This word with a warning triangle means there may be a considerable risk of fatal injury

- if the stated precautionary measures are not taken.
-

CAUTION!

Caution

This word with a warning triangle indicates that minor personal injury may occur

- if the stated precautionary measures are not taken.
-

ATTENTION!

Attention

This indicates that damage to property may occur

- if the stated precautionary measures are not taken.
-

Information

Information indicates important information about the product or serves to emphasize a section in the documentation that deserves special attention from the reader.

Embedded warning messages

Embedded warning messages are integrated directly into the instruction manual and are structured as follows:

SIGNAL WORD! Type of hazard, its cause and possible consequences of disregarding it! Measures for avoiding the hazard.

Signal words in embedded warning messages have the same meaning as in the normal warning messages described previously.

1.4 Terms

For reason of clarity, the collective term "drives" is used for gear units, motors and geared motors in this documentation.

1.5 Supporting documents

You can find supporting technical documents for this product when you enter the serial number of the product at <https://id.stober.com> or scan the QR code on the product's nameplate.

You will find more information about the product at <http://www.stober.de/en/downloads/>. Enter the ID of the documentation in the Search... field.

1.6 Limitation of liability

This documentation was created taking into account the applicable standards and regulations as well as the current state of technology.

No warranty or liability claims for damage shall result from failure to comply with the documentation or from use that deviates from the intended use of the product. This is especially true for damage caused by individual technical modifications to the product or the project configuration and operation of the product by unqualified personnel.

1.7 Product names and brands

Product names that are registered as brands are not specifically identified in this documentation. Existing property rights (patents, trademarks, protection of utility models) are to be observed.

1.8 Copyright notice

Copyright © STOBBER. All rights reserved.

2 Safety notes

There are risks associated with the product described in this documentation that can be prevented by complying with the following basic safety notes as well as the included technical rules and regulations.

2.1 Intended use

In this documentation, the gear racks described are used in connection with a drive for the conversion of rotational motion into linear motion. The gear racks are intended for installation in industrial machines or systems.

The following are considered non-intended use:

- Any overloading of the gear racks
- Operation in ambient conditions that deviate from those described in this document
- Modification of the gear racks

Commissioning the machine in which the gear racks are installed is prohibited until it has been determined that the machine corresponds to regional laws and guidelines. In particular, the (Machinery) Directive 2006/42/EC is to be observed in the respective scope.

Operation of the gear racks in potentially explosive atmospheres is prohibited.

2.2 Requirements for personnel

All tasks that arise during the assembly, commissioning, servicing and removal of the product may be performed only by specialized personnel. This specialized personnel must be able to evaluate the tasks assigned to them based on their education and experience to recognize and avoid dangers.

Tasks that arise during transport, storage and disposal may be performed by personnel who have been instructed in the suitable method for doing so.

Furthermore, personnel who handle the product must carefully read, understand and observe the valid regulations, legal requirements and applicable basic rules as well as this documentation and the safety notes it contains.

2.3 Prevention of personal injury

2.3.1 Mechanical hazards

 **WARNING!**

Dangerous movements of machine parts!

Moving machine parts can cause serious injuries or even death!

- ✓ Before starting the drive:
 - Install all protective devices necessary for operation.
 - Make sure that no one is standing in the danger area or able to enter it unchecked.
 - Leave the danger area.
-

 CAUTION!**The gear rack has sharp edges!**

Physical contact with sharp edges can cause cutting injuries!

- Wear protective gloves and safety shoes when working with the gear rack.
-

2.4 Prevention of property damage

ATTENTION! Damage to the gear rack due to hard impacts! When working on the gear rack, avoid impacts, setting down roughly or hitting with a hammer. Observe the instructions in this document.

3 Product description

In this chapter, you will find product details that are relevant for assembly, commissioning and servicing. Detailed technical data on your gear rack can be found in the order confirmation. You will find more product information and dimensional drawings in the corresponding catalog ([Additional documentation](#) |▶ 10]). The separate technical documentation for drives used in connection with the gear rack applies.

3.1 Basic structure

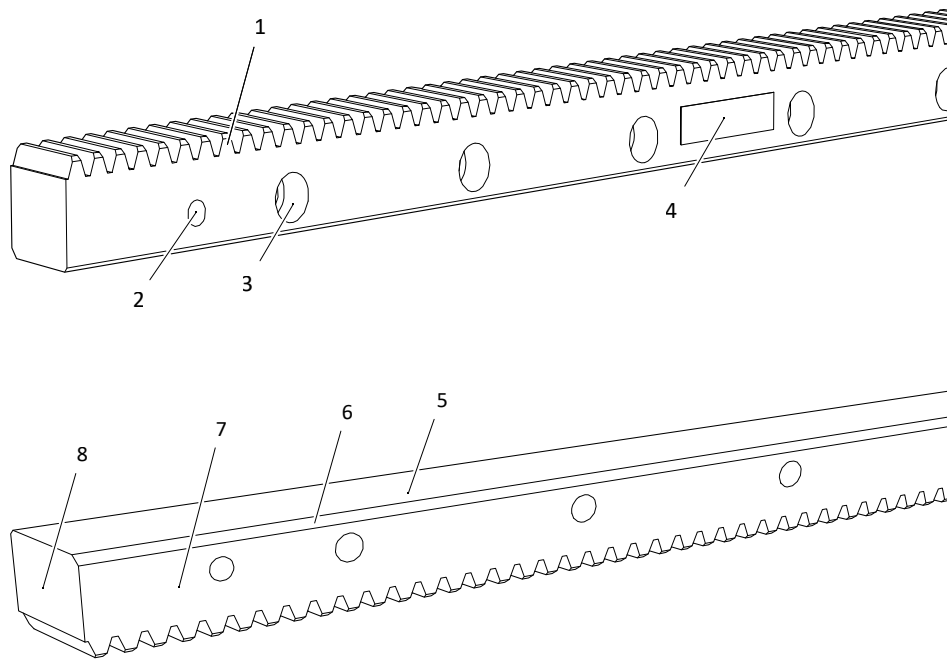

1	Toothing	2	Bore for cylindrical pin
3	Bore for cylinder screw	4	Nameplate
5	Contact side	6	Chamfer
7	Screw mounting side	8	Joint side

3.2 Type designation

In this chapter, you will find an explanation of the type designation of a gear rack with the associated options.

Example code

ZS	4	S	1000	S	Q6	V	G
----	---	---	------	---	----	---	---

Explanation

Code	Designation	Design
ZS	Type	Gear rack
4	Normal module	$m_n = 4$ mm (example)
S	Toothing	Helical (right-hand 19° 31' 42")
0500	Length	1000 mm (example)
1000		
S	Fastening bores	Standard
Q6	Gearing quality	Quality 6 in accordance with DIN 3962-1
V	Material	Heat-treatable steel in accordance with STOBER specification
G	Heat treatment	Hardened

3.3 Nameplate

An example gear rack nameplate is explained in the figure below.

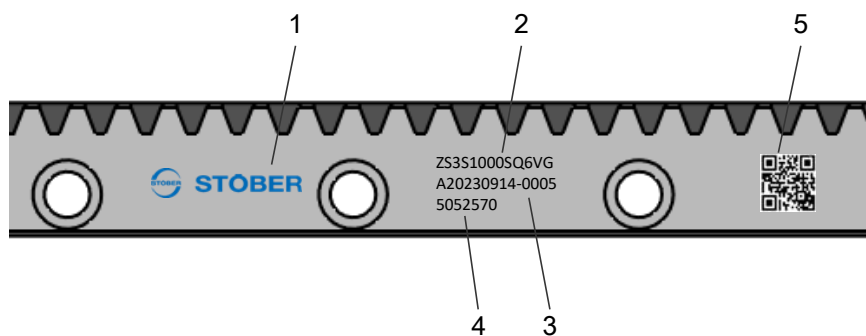

Code	Designation
1	Name of manufacturer
2	Type designation
3	Production number of the gear rack
4	ID No.
5	QR code (link to product information)

3.4 Ambient conditions

Standard ambient conditions for transport, storage and operation of the gear racks are described in this chapter. Deviating ambient conditions for special designs are specified in the order confirmation.

Feature	Description
Transport/storage surrounding temperature	-10 °C to +50 °C
Surrounding operating temperature	0 °C to +40 °C

Notes

In order to prevent corrosion damage, protect the gear rack from the following influences:

- Environments with harmful oils, acids, gases, vapors, dust or radiation
- Extreme temperature fluctuations with high humidity
- Condensation or icing
- Presence of salt spray
- Sparks

3.5 Additional documentation

You will find more information about the product at <http://www.stoeber.de/en/downloads/>. Enter the ID of the documentation in the Search... field.

Documentation	ID
Rack and pinion drives catalog	443137_en

4 Transport and storage

STOBER products are packaged carefully and delivered ready for installation. The type of packaging depends on the product size and the transport method.

Observe the following information during transport and storage:

- Inspect the delivery for any transport damage immediately upon receiving it and report any transport damage immediately. Do not put damaged products into operation.
- Check your delivery for completeness using the delivery note and report any missing parts to the supplier.
- Transport and store the product in the original packaging in order to protect it from damage. Remove the original packaging and transport safety devices shortly before assembly.

Ambient conditions

The ambient conditions for transport and storage can be found in the chapter [Ambient conditions \[► 10\]](#).

4.1 Storage

Store gear racks horizontally in a dry, dust-free environment in the original packaging at a storage temperature between -10 °C and $+50\text{ °C}$.

4.2 Transport

WARNING!

Suspended loads!

Loads that become loose and fall during the lifting process can cause serious injuries or even death!

- Observe the following instructions.
- Cordon off the danger zone and ensure that no one stands under the suspended loads.
- Wear safety shoes.

Lifting and transporting the gear racks may require lifting gear (e.g. a crane), depending on the weight. The weight of your gear rack is specified in the accompanying delivery documents.

5 Installation

This chapter contains information on how to correctly mount STOBER gear racks and avoid injury to persons or damage to property.

Inspect the gear rack for transport or storage damage. If the gear rack is damaged, do not install it. Contact the STOBER Service department.

5.1 Requirements for the connecting structure

To ensure that the gear rack is installed correctly and the machine operates flawlessly, the connecting structure and installation location must correspond to the following requirements.

- The installation location of the gear rack must be clean and dry, as dust and fluids can impair the function of the rack and pinion drive.
- The gear rack has a chamfer between the contact side and screw mounting side to allow for easy installation onto the connecting structure. The dimensions of the chamfer can be found in the dimensional drawings in the product catalog.
- STOBER recommends the following shape and position tolerances for the connecting structure, which apply to gear racks with a length of 1 m.
- The recommended parallelism tolerance of the connecting structure for the drive depends on the required smooth operation and positioning accuracy as well as on the size of the mounting surface (dimension a1) as follows.

Requirements for smooth operation and positioning accuracy	Parallelism tolerance pt [μm], based on a1 = 100 mm
High	10
Normal	15
Low	30

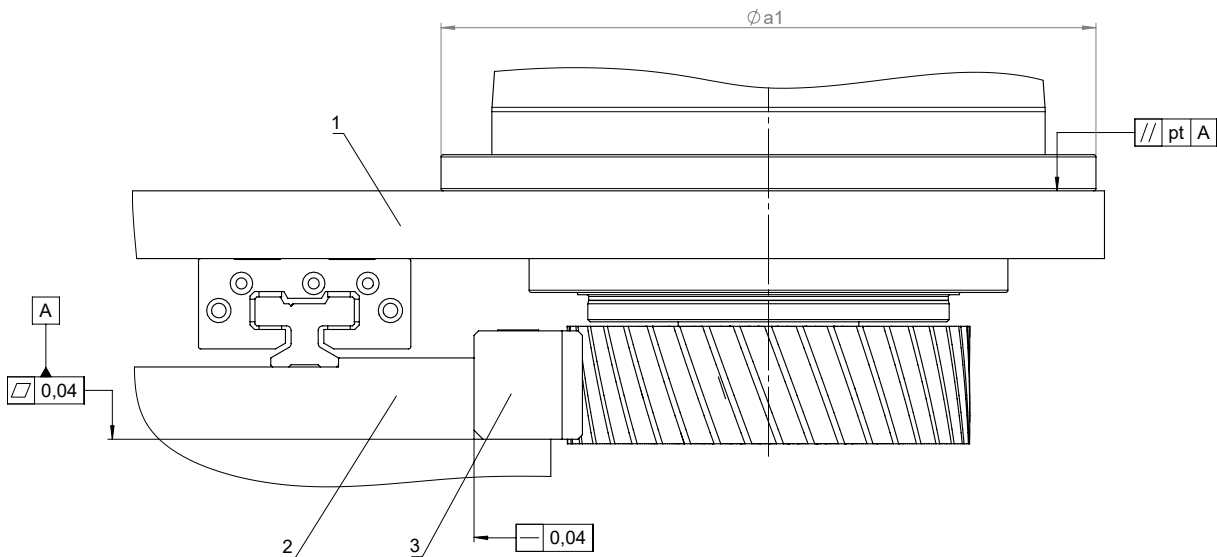

Fig. 1: Shape and position tolerances for the connecting structure

- | | | | |
|---|------------------------------------|---|-----------|
| 1 | Connecting structure for drive | 2 | Gear rack |
| 3 | Connecting structure for gear rack | | |

5.2 Tools

The following tools are required for mounting a gear rack:

- If necessary due to the weight, lifting gear with appropriate fastening elements and sufficient lifting capacity
- Cleaning agent
- Sharpening stone
- Clamps with protective caps or intermediate layers made of plastic
- Torque wrench with hexagon sockets
- Drill (diameters are specified in the chapter [Securing a gear rack with pins \[▶ 17\]](#))
- Reamer (diameters are specified in chapter [Securing a gear rack with pins \[▶ 17\]](#))

If you want to mount multiple gear racks next to each other, you need the following tools:

- Mounting gear rack with the same module as the gear racks. Mounting gear racks can be obtained as accessories from STOBBER.
- Dial gauge with measurement bridge
- 3 needle rollers (diameters are specified in the chapter [Checking the transition between the gear racks \[▶ 16\]](#))
- Magnet for magnetizing the needle rollers
- Dead blow hammer
- Copper punch

5.3 Cleaning agent and solvent

Upon delivery, the gear rack is protected by a corrosion protection agent. The corrosion protection agent must be removed from all contact surfaces of the gear rack with the connecting structure before assembly. STOBBER recommends removing the corrosion protection with a suitable cold cleaner (e.g. Carlofon Autocleaner) which, in contrast to volatile solvents, is almost odorless. Otherwise, you can use commercially available solvents.

5.4 Preparing for installation

Before installing the gear racks, carry out the following tasks.

1. Unpack the gear racks.
2. Leave the unpacked gear racks in the installation space until they reach the room temperature.
3. Clean the contact surfaces of the gear racks and grind them down with a sharpening stone if necessary.
4. Clean the contact surfaces of the connecting structure and grind them down with a sharpening stone if necessary.

5.5 Installing the first gear rack

If you want to install three or more gear racks next to each other, start in the center of the connecting structure.

The connecting structure must have a suitable mating surface counterface for applying the clamps that are used during installation.

1. Position the gear rack (6) on the screw mounting surface (1) so that the through-holes of the gear rack are aligned centrally with the threaded holes in the screw mounting surface.
2. Clamp the gear rack to the mounting surface (7) using clamps (4) near every second through-hole (starting from the outside). Use intermediate layers, e.g. made of plastic (2), so that the toothing is not damaged.

3. Screw cylinder screws (3) into the through-holes.
4. Tighten the cylinder screws with the tightening torque specified below, starting from the center outward.
5. Remove the clamps.

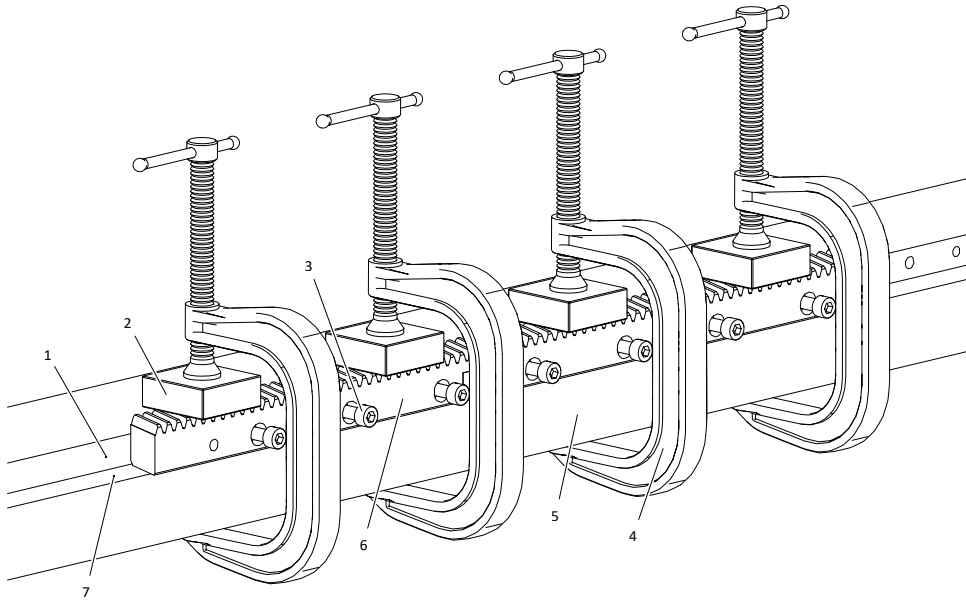

Fig. 2: Installation of a gear rack on the connecting structure (example)

- | | | | |
|---|------------------------|---|--------------------|
| 1 | Screw mounting surface | 2 | Intermediate layer |
| 3 | Cylinder screw | 4 | Clamp |
| 5 | Connecting structure | 6 | Gear rack |
| 7 | Contact surface | | |

Type	Number of screws ¹	Screw size	Strength class	Tightening torque [Nm]
ZS2S500S	4/7	M6	12.9	18
ZS2S1000S	8/15	M6	12.9	18
ZS3S500S	4/7	M8	12.9	43
ZS3S1000S	8/15	M8	12.9	43
ZS4S500S	4/7	M10	12.9	84
ZS4S1000S	8/15	M10	12.9	84
ZS5S500S	4/7	M12	12.9	145
ZS5S1000S	8/15	M12	12.9	145
ZS6S500S	4/7	M16	12.9	365
ZS6S1000S	8/15	M16	12.9	365

Tab. 1: Specifications for cylinder screws for installing the gear rack

¹The number of screws depends on feed forces that were calculated during the design of the rack and pinion drive

5.6 Installing another gear rack

The end of a gear rack and the start of another gear rack each form a half tooth gap. A narrow gap remains between the correctly installed gear racks that allows the gear racks to be adjusted.

Installation of another gear rack is described below.

1. Position another gear rack (5) at the end of the preceding gear rack (7). Note that a gear rack with a length of 500 mm and module 4 can be installed only to the right of a gear rack with a length of 1000 mm due to the design.
2. Position the mounting gear rack (1) in a center position above the joint between the gear racks and use a clamp (2) to clamp it onto the connecting structure (4).
3. Using a clamp (2) with intermediate layer (3), clamp the gear rack (5) onto the connecting structure near the first through-hole.
4. Screw a cylinder screw (6) into the first through-hole.
5. Tighten the cylinder screw with half of the specified tightening torque (see chapter [Installing the first gear rack \[▶ 13\]](#)).
6. Repeat steps 3 through 5 for all other cylinder screws.
7. Remove the mounting gear rack.
8. Check the transition between the gear racks (see chapter [Checking the transition between the gear racks \[▶ 16\]](#)).
9. Tighten all cylinder screws with the tightening torque specified below.
10. Remove the clamps.

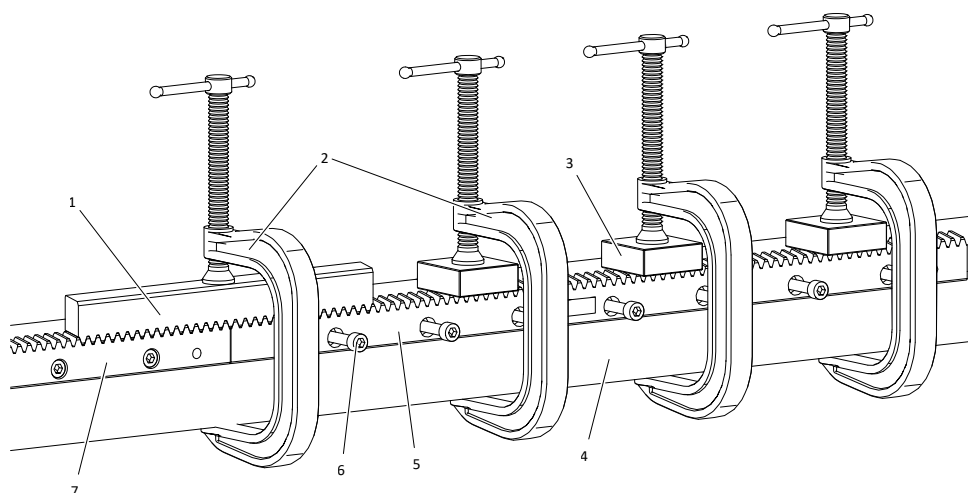

Fig. 3: Assembly of another gear rack (example)

1	Mounting gear rack	2	Clamp
3	Intermediate layer	4	Connecting structure
5	(Another) gear rack	6	Cylinder screw
7	(Preceding) gear rack		

5.7 Checking the transition between the gear racks

ATTENTION! Particles of iron are stuck to a magnetized gear rack and can damage the tothing. Do not place magnets near the gear rack.

1. Magnetize the 3 needle rollers with the magnet so they remain in their positions.
2. Position the measurement bridge (2) with dial gauge (1) on a surface-ground surface and set the dial gauge to zero.
3. Place a needle roller (5) in the tooth gap at the joint between the gear racks.
4. Place one needle roller each in the tooth gap to the right (4) and left (6) of the joint.
5. Position the measurement bridge with dial gauge on the needle rollers so that the dial gauge button can sample the center needle roller.
6. Move the measurement bridge slightly to the right and left and read off the maximum deviation on the dial gauge.
7. If the deviation is outside the tolerance range (in the following table), lightly tap the downstream gear rack with a dead blow hammer to correct its position. If necessary, use a copper punch that you attach to a mounting hole in the gear rack.
8. If the deviation is within the tolerance range, continue the installation (see previous chapter).

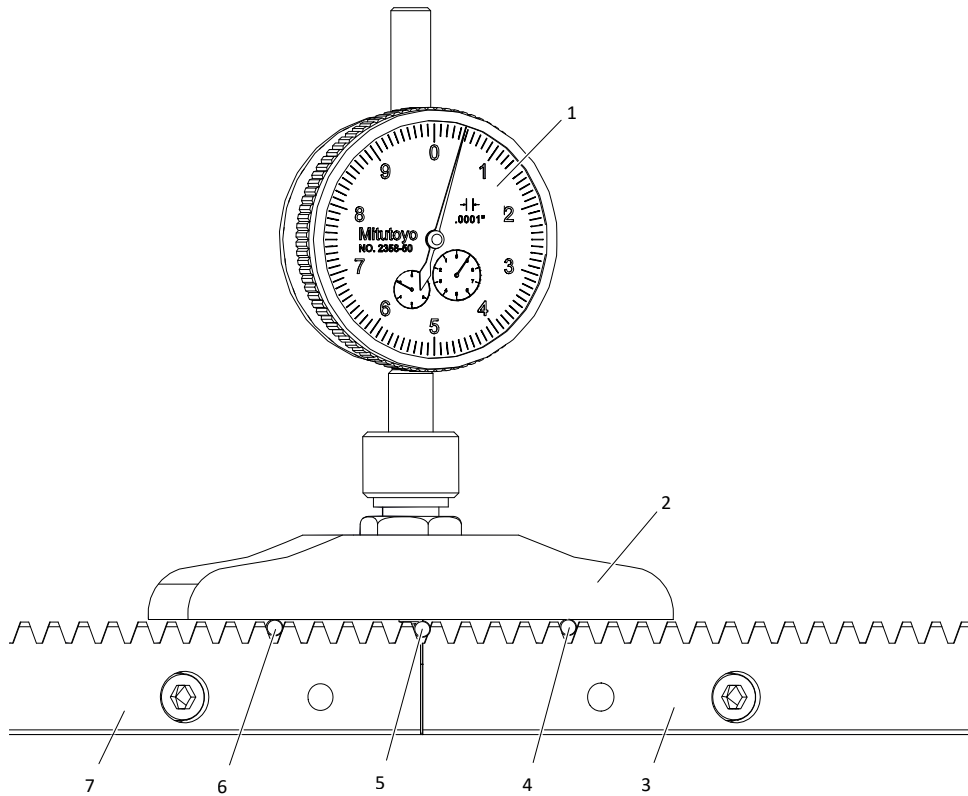

Fig. 4: Checking the transition between two gear racks (example)

1	Dial gauge	2	Measurement bridge
3	(Next) gear rack	4	Needle roller (right)
5	Needle roller (at the transition)	6	Needle roller (left)
7	(Preceding) gear rack		

Module [mm]	∅ of needle roller [mm]	Tolerance range ² [mm]
2	4.0	± 0.01
3	6.0	± 0.011
4	8.0	± 0.011
5	10.0	± 0.016
6	12.0	± 0.016

Tab. 2: Needle rollers and tolerance ranges

5.8 Securing a gear rack with pins

If required by the design of your rack and pinion drive, secure the position of the gear rack with cylindrical pins.

STOBER recommends using hardened cylindrical pins with internal thread in accordance with EN ISO 8735. The internal thread allows the cylindrical pins to be easily removed again if needed.

For drilling the pin bores, STOBER recommends a magnetic drill, for which suitable surfaces have been provided in the connecting structure.

Specifications for required drills and cylindrical pins can be found in the following table.

1. Drill the pin bores in the connecting structure. Guide the drill through the respective bore (4) in the gear rack to do so.
2. Ream the bores in the gear rack together with those in the connecting structure to fit size H7 for the cylindrical pins.
3. Remove chips with a vacuum.
4. Hammer the cylindrical pins (3) into the bores.

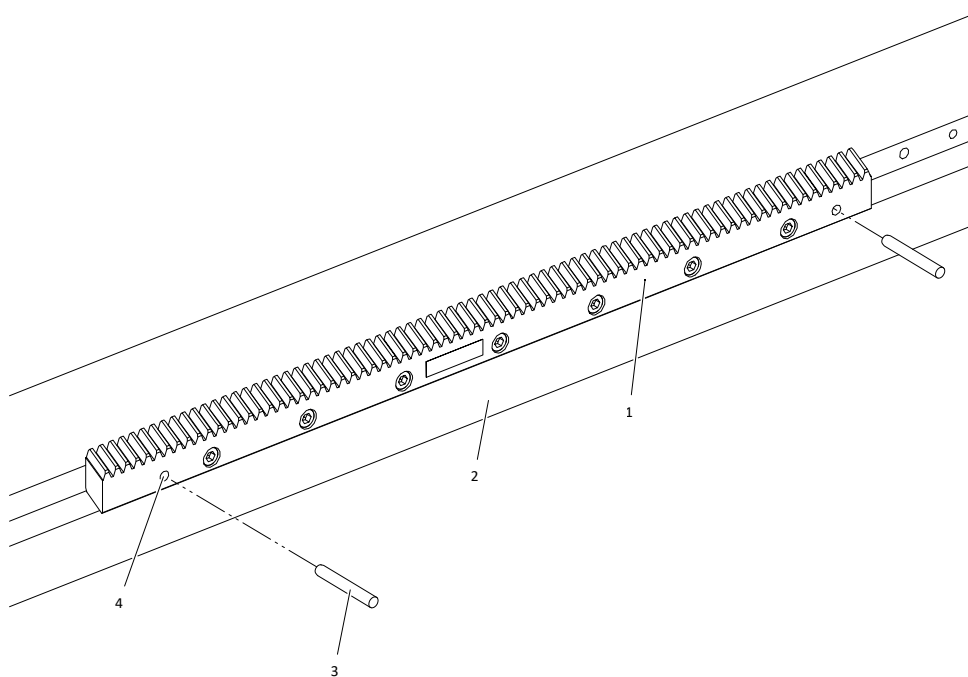

Fig. 5: Securing a gear rack with pins (example)

- | | | | |
|---|-----------------|---|----------------------------|
| 1 | Gear rack | 2 | Connecting structure |
| 3 | Cylindrical pin | 4 | Bore (for cylindrical pin) |

²The diameters of the needle rollers used must not deviate from each other by more than ± 0.001 mm

Module [mm]	Bore \varnothing [mm]	Cylindrical pin size [mm]	Number per gear rack
2	5.7	6 m6	2
3	7.7	8 m6	2
4	11.7	12 m6	2
5	11.7	12 m6	2
6	15.7	16 m6	2

Tab. 3: Recommended cylindrical pins in accordance with EN ISO 8735

5.9 Installing the gear unit with pinion

Installation of a gear unit with pinion, which is done after the gear racks are installed, is described below. In the design, there must be a device to adjust the distance between the pinion shaft and gear rack. An adjustment plate is described here as an example of an adjustment option. You can find the nominal distance between the pinion shaft and gear rack in the dimensional drawing in the catalog (dimension az).

Observe the information on installation in the technical documentation of the drive.

STOBER recommends, if possible, to first install the gear unit without a motor so the gear unit can be moved along the gear rack by hand and the center distance can be adjusted.

If you want to install the gear unit with the motor fitted, STOBER recommends pushing the pinion gearing into the gear rack radially. The design must include a correspondingly large adjustment range for the center distance. If you initially install just the gear unit, you can also push the pinion gearing into the gear rack in the axial direction by turning the output shaft via the coupling on the input drive.

5. Install the gear unit (1) with the adjustment plate (4). In the process, initially position the adjustment plate with the gear unit so that the distance between the pinion (9) and gear rack (6) is as large as possible.
6. Loosen the cylinder screws (5) in the adjustment plate.
7. Push the gear unit to the gear rack radially by hand until the pinion is seated in the toothing of the gear rack with low backlash.
On ZR pinions from STOBER, the tooth with the highest radial runout deviation is marked with a dot.
8. Tighten the cylinder screws in the adjustment plate.
9. Move the gear unit in the guide along the entire travel path to check if this is possible at all positions when an equal level of force is applied. The running noise should also remain consistent. There must be no knocks at the transitions between the gear racks.
1. **ATTENTION! If the pinion is mounted on the gear rack under pretension, this can result in premature wear, toothing damage or rolling bearing damage in the drive!** The tooth flanks of the pinion and gear rack should be in contact at their highest positions without backlash and pretension. Flank play is possible in some parts of the travel path.
10. If necessary, correct the distance between the pinion shaft and gear rack using the adjustment plate. STOBER recommends gearing play of 0.02 mm, which corresponds to a radial distance of 0.03 mm between the pinion gearing and gear rack.

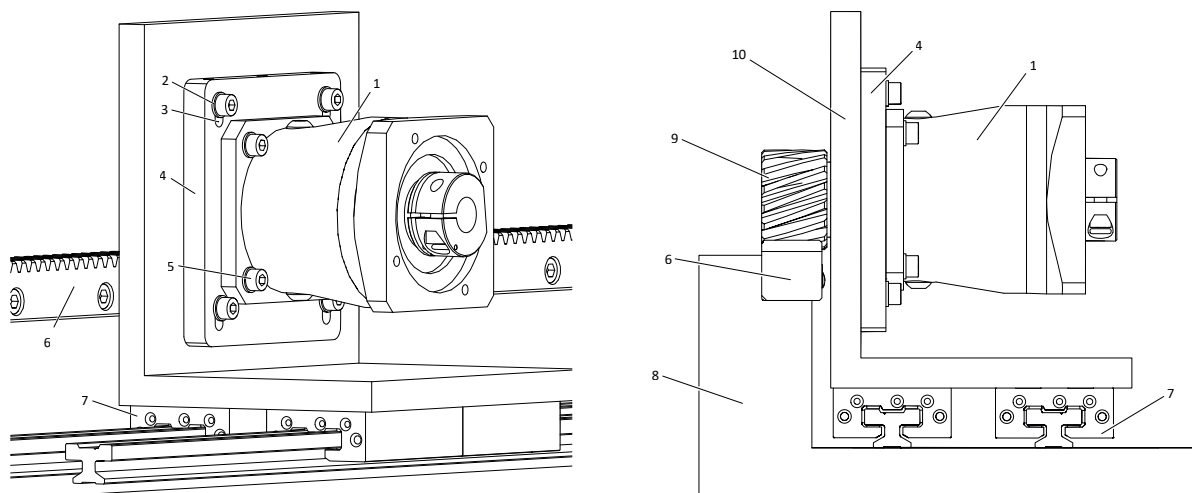

Tab. 4: Mounting a gear unit with pinion and adjustment plate (example)

1	Gear unit	2	Washer
3	Slot (in adjustment plate)	4	Adjustment plate
5	Cylinder screw	6	Gear rack
7	Linear guide	8	Connecting structure for the gear rack
9	Pinion	10	Connecting structure for the gear unit

5.10 Final inspection

After installing the gear rack and drive, carry out the following final inspection.

1. Degrease the tooth flanks of the gear rack.
2. Coat the tooth flanks with spotting paste.
3. Move the drive back and forth along the gear rack several times.
4. Check the areas of the tooth flanks in which the spotting paste has been removed.
5. Using the following example contact patterns, assess whether the gear unit is correctly aligned with the gear rack.
6. If required, correct the position of the gear unit and repeat the previous steps.

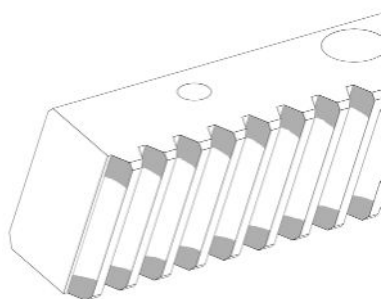

Correct

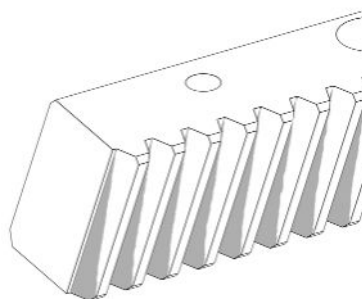

Not parallel

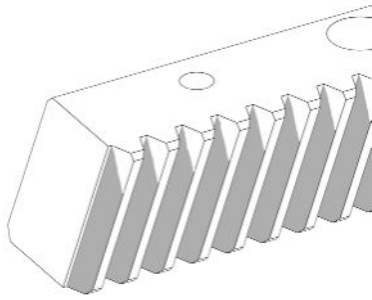

Not a right angle

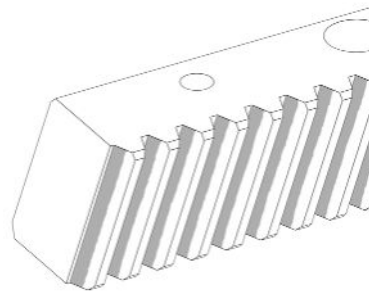

Incorrect center distance

Tab. 5: Examples of contact patterns

5.11 Ensuring lubrication

ATTENTION! A lack of or no lubrication of the gear rack and pinion results in toothing damage during operation.

- Install a lubrication system that ensures lubrication of the rack and pinion drive during operation.
- Before commissioning the gear rack, clean and lubricate the gear rack and pinion manually.

Lubricants

STOBER recommends the following lubricants for the rack and pinion drive:

- Klüber Microlube GB 0
- Klüber Structovis AHD
- Oest Langzeitfett LT 200
- BP Energ grease LS EP 00
- DEA Glissando 6833 EP 00
- Fuchs Lubritech Gearmaster ZSA
- Molykote G-Rapid plus 3694

Metering quantities

In the following table, you will find metering quantities for lubrication gears made of felt or PU foam, which can be engaged in the pinion or gear rack depending on the design conditions.

Feed velocity (v) [m/s]	$v \leq 1$	$1 < v \leq 2$	$2 < v \leq 3$	$3 < v \leq 4$	$v > 4$
Module [mm]	Daily ³ metering quantity [cm ³]				
2	0.25	0.5	0.75	1	1.25
3	0.25	0.65	1	1.25	1.5
4	0.25	0.75	1.25	1.5	2
5	0.25	1	1.5	2	2.5
6	0.25	1.25	1.75	2.5	3

Tab. 6: Metering quantities for felt or PU gears

STOBER recommends a metering quantity that is 1.5 to 2 times higher for lubrication with a lubricant brush and for drip lubrication or injection lubrication.

³in relation to single-shift operation

Provider of lubrication systems and lubricants

You can purchase lubrication systems and lubricants compatible with rack and pinion drives from the following providers:

DLS Schmiersysteme GmbH www.dls-schmiersysteme.de	Gruetzner GmbH www.g-lube.com
STW - Kim Friedrich GmbH https://schmiertechnikwerk.com/	

6 Commissioning

6.1 Before commissioning

WARNING! Moving machine parts can cause serious injuries or even death! Before performing work, switch off the machine with the main switch and secure the switch from being turned on again.

Before commissioning the drive, make sure that the following prerequisites are met:

- The drive is undamaged
- The gear rack and pinion are lubricated
- The mechanical assembly and electrical connection of the drive has been completed
- The drive is not blocked
- All protective devices have been properly mounted
- All monitoring equipment is activated
- The drive controller is adjusted so that an overload of the gear unit in relation to the permitted torque is prevented by the motor
- The ambient conditions are observed (see [Ambient conditions](#) [[▶ 10](#)])

6.2 During commissioning

WARNING! Moving machine parts can cause serious injuries or even death! Make sure that no one is standing in the danger area or able to enter it unchecked.

WARNING! Falling gravity-loaded axes or vertical axes can cause serious injuries or even death! Move gravity-loaded axes or vertical axes to their lowest position and lock or brace them mechanically before entering the danger area.

CAUTION! The surface of the drive can reach temperatures over 65 °C during operation! Allow the drive to cool sufficiently before working on it. Wear gloves.

During commissioning, check the following:

- Is the direction of rotation of the drive correct?
- When the drive is running, do any overloading, unwanted speed fluctuations, unusual noises or vibrations occur?

7 Servicing

7.1 Inspection

WARNING! Moving machine parts can cause serious injuries or even death! Before performing work, switch off the machine with the main switch and secure the switch from being turned on again.

WARNING! Falling gravity-loaded axes or vertical axes can cause serious injuries or even death! Move gravity-loaded axes or vertical axes to their lowest position and lock or brace them mechanically before entering the danger area.

CAUTION! Physical contact with sharp edges of the gear rack can cause cutting injuries! Wear protective gloves and safety shoes when working with the gear rack.

Determine the inspection interval according to the expected operating conditions of the motor; however, every 3 months at the latest.

Perform inspections on the gear rack in accordance with the following specifications.

Observe the information on inspections in the technical documentation of the drive and lubrication system.

Interval	Task
Every 500 operating hours or every 3 months	Visual inspection for external damage and sufficient lubrication. Cleaning the gear rack and pinion.

7.2 Cleaning

WARNING! Moving machine parts can cause serious injuries or even death! Before performing work, switch off the machine with the main switch and secure the switch from being turned on again.

WARNING! Falling gravity-loaded axes or vertical axes can cause serious injuries or even death! Move gravity-loaded axes or vertical axes to their lowest position and lock or brace them mechanically before entering the danger area.

CAUTION! Physical contact with sharp edges of the gear rack can cause cutting injuries! Wear protective gloves and safety shoes when working with the gear rack.

Observe the information on cleaning in the technical documentation of the drive and lubrication system.

Clean the drive according to the following instructions.

- Remove dust and chips with a suitable industrial vacuum.
- Clean the tothing of the gear rack and pinion with a suitable cleaning agent.
- Before commissioning the gear rack, clean and lubricate the gear rack and pinion manually.

7.3 Remediating faults

WARNING! Moving machine parts can cause serious injuries or even death! Before performing work, switch off the machine with the main switch and secure the switch from being turned on again.

Notify all personnel working on the machine or the drive of deviations from normal operation. These deviations indicate that the function of the drive is impaired. These include:

- Higher operating temperatures or increased vibrations
- Unusual noises or smells
- Triggering of monitoring systems

In such an event, shut down the drive and notify the responsible service personnel immediately.

7.3.1 Troubleshooting faults

The following table describes faults that can occur during the operation of the rack and pinion drive. You can find information on faults in the lubrication system in the corresponding documentation.

Faults	Possible causes	Actions
Unusual operating noises	A lack of or no lubrication	Check lubrication system according to documentation
	Toothing damage	Check the design and installation of the rack and pinion drive; replace defective components
	Pinion braced against gear rack	Check the installation according to chapter Installing the gear unit with pinion [▶ 18]
	Gear rack incorrectly mounted	Check the installation according to chapter Final inspection [▶ 19]
Toothing damage such as wear, pitting or broken toothing	A lack of or no lubrication	Check lubrication system according to documentation
	Gear rack incorrectly mounted	Check the installation according to chapter Final inspection [▶ 19]
	Overload of the drive	Check the design of the rack and pinion drive
Position deviation within the travel path or increased flank play	Center distance incorrectly set	Set the center distance according to chapter Installing the gear unit with pinion [▶ 18]

7.4 Servicing

Have the necessary servicing work carried out on the rack and pinion drive by the specialist personnel. Be aware that improper servicing may cause material damage and may void the manufacturer's warranty.

Only use replacement parts delivered by STÖBER. Specify the type designation and ID of the gear rack when ordering replacement parts. These can be found on the nameplate of the gear rack.

7.5 Service

If you contact STÖBER Service, have the following information ready:

- Serial number and type designation of the gear rack according to the nameplate
- Type of fault and surrounding circumstances
- Presumed cause
- If possible, digital photo of the gear rack in connection with the fault

Contact data of parent company in Germany

STÖBER Antriebstechnik GmbH + Co. KG

Kieselbronner Strasse 12

75177 Pforzheim

Germany

Service hotline: +49 7231 582-3000

mail@stoeber.de

Contact data of subsidiary in US

STOBER Drives Inc.
1781 Downing Drive
Maysville, KY 41056
Service Hotline +1 606 563-6035
service@stober.com

8 Removal and disposal

8.1 Removal

WARNING! Moving machine parts can cause serious injuries or even death! Before performing work, switch off the machine with the main switch and secure the switch from being turned on again.

WARNING! Falling gravity-loaded axes or vertical axes can cause serious injuries or even death! Move gravity-loaded axes or vertical axes to their lowest position and lock or brace them mechanically before entering the danger area.

CAUTION! Physical contact with sharp edges of the gear rack can cause cutting injuries! Wear protective gloves and safety shoes when working with the gear rack.

Remove a gear rack as follows:

1. Remove or position the drive so that the pinion does not impede removal of the gear rack.
2. Remove the cylindrical pins being used to pin the gear rack.
3. Unscrew and remove all screws being used to mount the gear rack. If the gear rack is replaced with a new one, new screws must be used.
4. Remove the gear rack from the machine. Use lifting gear for this process if this is necessary due to the weight of the gear rack.

8.2 Disposal

Dispose of the gear rack as scrap steel according to applicable national regulations. Observe the information on disposal of the lubrication system in the corresponding documentation.

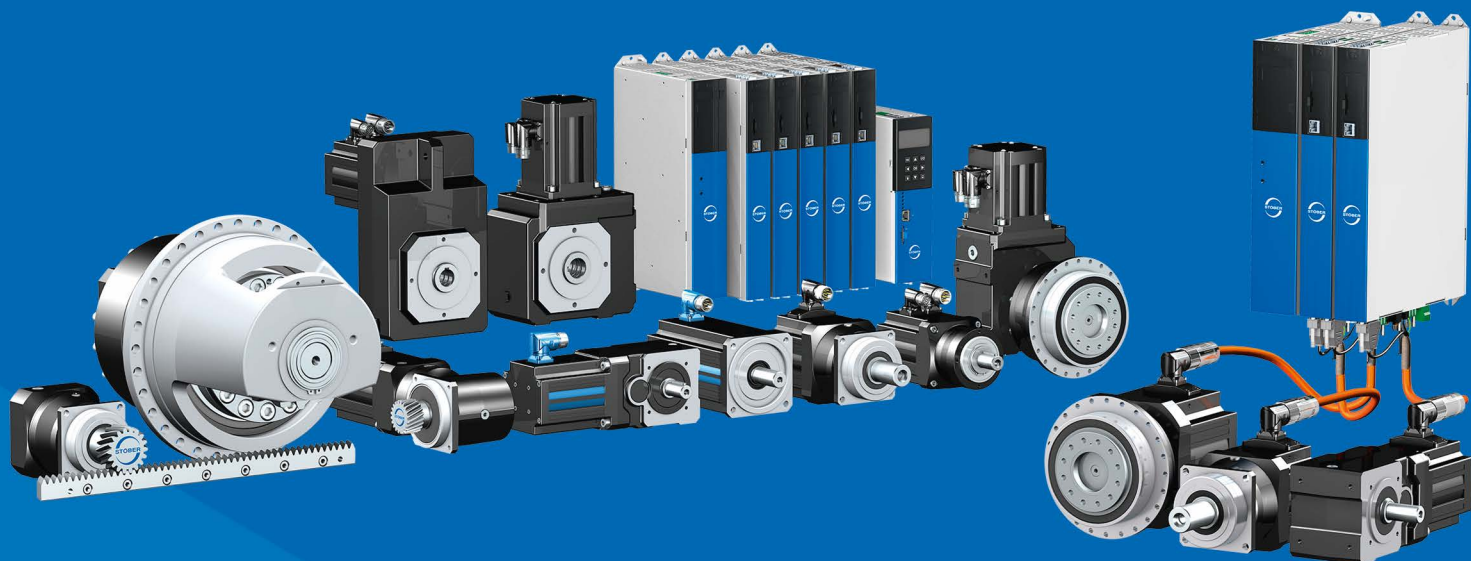

443392_en.00

04/2024

STÖBER Antriebstechnik GmbH + Co. KG
Kieselbronner Str. 12
75177 Pforzheim
Germany
Tel. +49 7231 582-0
mail@stoerber.de
www.stober.com

24 h Service Hotline
+49 7231 582-3000



STÖBER

www.stober.com