

# KL10 – KL20 gear units, geared motors

## Operating manual

en-US  
07/2023  
ID 443363\_en.00



**STÖBER**

# Table of contents

<b>1</b>	<b>User information</b> .....	<b>4</b>
1.1	Storage and transfer.....	4
1.2	Original language.....	4
1.3	Formatting conventions .....	4
1.4	Terms.....	5
1.5	Supporting documents .....	5
1.6	Limitation of liability.....	5
1.7	Product names and brands.....	5
1.8	Copyright notice .....	5
<b>2</b>	<b>Safety notes</b> .....	<b>6</b>
2.1	Intended use.....	6
2.2	Requirements for personnel.....	6
2.3	Prevention of personal injury .....	6
2.3.1	Mechanical hazards .....	6
2.3.2	Thermal hazards .....	7
2.4	Prevention of property damage .....	7
<b>3</b>	<b>Product description</b> .....	<b>8</b>
3.1	Basic structure .....	8
3.2	Type designation .....	8
3.3	Nameplate .....	9
3.4	Mounting positions .....	10
3.5	Direction of rotation.....	10
3.6	Ambient conditions .....	11
3.7	Other product features.....	12
3.8	Additional documentation.....	12
<b>4</b>	<b>Transport and storage</b> .....	<b>13</b>
4.1	Transport .....	13
4.2	Storage .....	13
4.2.1	Long-term storage .....	14
<b>5</b>	<b>Installation</b> .....	<b>15</b>
5.1	Cleaning agent and solvent .....	15
5.2	Permitted tilting torques at the gear unit input.....	15
5.3	Tolerances for the add-on motor .....	15
5.4	Mounting the motor on a gear unit.....	17

---

5.5	Mounting the output shaft.....	19
5.5.1	Mounting drive elements on a solid shaft.....	19
5.5.2	Mounting a hollow shaft with keyway.....	20
5.5.3	Mounting a hollow shaft with shrink ring.....	21
5.6	Mounting the gear unit on the machine.....	22
5.6.1	Mounting the torque arm bracket.....	24
5.7	Tightening torques.....	25
<b>6</b>	<b>Commissioning.....</b>	<b>27</b>
6.1	Before commissioning.....	27
6.2	During commissioning.....	27
<b>7</b>	<b>Servicing.....</b>	<b>28</b>
7.1	Cleaning.....	28
7.2	Inspection.....	28
7.3	Remedying faults.....	29
7.3.1	Troubleshooting faults.....	29
7.4	Servicing.....	29
7.5	Service.....	30
<b>8</b>	<b>Removal and disposal.....</b>	<b>31</b>
8.1	Removal.....	31
8.1.1	Removing a hollow shaft with keyway.....	31
8.2	Disposal.....	32

# 1 User information

This documentation is a part of the product. It applies to products in the standard design according to the corresponding STOBER catalog.

## 1.1 Storage and transfer

As this documentation contains important information for handling the product safely and efficiently, it must be stored in the immediate vicinity of the product until product disposal and be accessible to qualified personnel at all times.

Also pass on this documentation if the product is transferred or sold to a third party.

## 1.2 Original language

The original language of this documentation is German; all other language versions are derived from the original language.

## 1.3 Formatting conventions

Orientation guides in the form of signal words are used to emphasize specific information so that you are able identify it in this documentation quickly.

Safety notes indicate special risks when handling the product and are accompanied by relevant signal words that express the extent of the risk. In addition, warning messages for possible property damage and useful information are also indicated by signal words.

---

### **WARNING!**

#### **Warning**

This word with a warning triangle means there may be a considerable risk of fatal injury

- if the stated precautionary measures are not taken.
- 

### **CAUTION!**

#### **Caution**

This word with a warning triangle indicates that minor personal injury may occur

- if the stated precautionary measures are not taken.
- 

### **ATTENTION!**

#### **Attention**

This indicates that damage to property may occur

- if the stated precautionary measures are not taken.
- 

### **Information**

Information indicates important information about the product or serves to emphasize a section in the documentation that deserves special attention from the reader.

---

## Embedded warning messages

Embedded warning messages are integrated directly into the instruction manual and are structured as follows:

**SIGNAL WORD! Type of hazard, its cause and possible consequences of disregarding it!** Measures for avoiding the hazard.

Signal words in embedded warning messages have the same meaning as in the normal warning messages described previously.

## 1.4 Terms

This documentation describes both STOBBER gear units and gear components of STOBBER geared motors. For reasons of clarity, the collective term drives is used for these.

## 1.5 Supporting documents

Separate documents apply to the drive components which can be attached to STOBBER gear units, depending on the design. These documents can be found by entering the serial number of the gear unit at <https://id.stober.com> or by scanning the QR code on the nameplate of the gear unit.

Alternatively, you can find supporting documents at <http://www.stober.de/en/downloads/>. Enter the ID of the documentation in the Search... field:

Drive components	Operating manual ID
LM Lean motor	443048_en
EZ synchronous servo motor	443032_en

## 1.6 Limitation of liability

This documentation was created taking into account the applicable standards and regulations as well as the current state of technology.

No warranty or liability claims for damage shall result from failure to comply with the documentation or from use that deviates from the intended use of the product. This is especially true for damage caused by individual technical modifications to the product or the project configuration and operation of the product by unqualified personnel.

## 1.7 Product names and brands

Product names that are registered as brands are not specifically identified in this documentation. Existing property rights (patents, trademarks, protection of utility models) are to be observed.

## 1.8 Copyright notice

Copyright © STOBBER. All rights reserved.

## 2 Safety notes

There are risks associated with the product described in this documentation that can be prevented by complying with the following basic safety notes as well as the included technical rules and regulations.

### 2.1 Intended use

The drives described in this documentation are intended for installation in industrial machines or systems.

The following are considered non-intended use:

- Any overloading of the drives
- Operation in ambient conditions that deviate from those described in the corresponding technical documentation
- Modifying or refitting the drives
- Using the drives for an application other than that defined during project configuration

Commissioning the machine in which the drives are installed is prohibited until it has been determined that the machine corresponds to regional laws and guidelines. In particular, the (Machinery) Directive 2006/42/EC is to be observed in the respective scope.

Operation of the drives in potentially explosive atmospheres is prohibited, unless they are expressly designed for this.

### 2.2 Requirements for personnel

All mechanical tasks that arise during the assembly, commissioning, maintenance and removal of the product may be performed only by specialized personnel who hold a corresponding qualification in the field of metal technology.

All electrical tasks that arise during the assembly, commissioning, maintenance and removal of the product may be performed only by electrically skilled persons who hold a corresponding qualification in the field of electrical engineering.

Tasks that arise during transport, storage and disposal may be performed by personnel who have been instructed in the suitable method for doing so.

Furthermore, personnel who handle the product must carefully read, understand and observe the valid regulations, legal requirements and applicable basic rules as well as this documentation and the safety notes it contains.

### 2.3 Prevention of personal injury

#### 2.3.1 Mechanical hazards

#### **WARNING!**

##### **Dangerous movements of machine parts!**

Moving machine parts can cause serious injuries or even death!

- ✓ Before starting the drive:
  - Install all protective devices necessary for operation.
  - Make sure that no one is standing in the danger area or able to enter it unchecked.
  - Leave the danger area.

---

**⚠ WARNING!****Sinking or falling of gravity-loaded axes or vertical axes after switching off the motor due to gravity!**

Falling gravity-loaded axes or vertical axes can cause serious injuries or even death!

- Be aware that the holding brake of the motor does not offer sufficient safety for persons that are in the hazard area of gravity-loaded axes or vertical axes.
  - Move gravity-loaded axes or vertical axes to their lowest position and lock or brace them mechanically before allowing people to enter the danger area.
- 

**⚠ WARNING!****Unsecured feather keys or drive elements can be thrown due to the rotation of the input shaft!**

Flying metal parts can cause serious injuries!

- Mount the provided drive elements properly or remove them before a test run.
- 

## 2.3.2 Thermal hazards

**⚠ CAUTION!****The surface of the drive can reach temperatures over 65 °C during operation!**

Touching the hot surface of the drive can cause severe skin burns!

- Do not touch the drive during operation or immediately afterward.
  - Allow the drive to cool sufficiently before carrying out work on the drive.
  - Wear protective gloves when working on the drive.
- 

## 2.4 Prevention of property damage

**ATTENTION! Damage to bearings and shafts due to improper assembly!** Never use force when installing machine elements with fittings, e.g. hitting power transmission elements, shafts or the motor or gear housing with a hammer, but rather install them in accordance with the following instructions.

**ATTENTION! Shaft seal rings can be damaged by solvents!** Prevent shaft seal rings from coming into contact with solvents when cleaning and degreasing unpainted surfaces.

## 3 Product description

In this chapter, you will find product details that are relevant for assembly, commissioning and servicing. Detailed technical data on your drive can be found in the order confirmation. You will find more product information and dimensional drawings in the corresponding catalog ([Additional documentation](#) |> 12]). The respective separate technical documentation applies to attached motors.

### 3.1 Basic structure

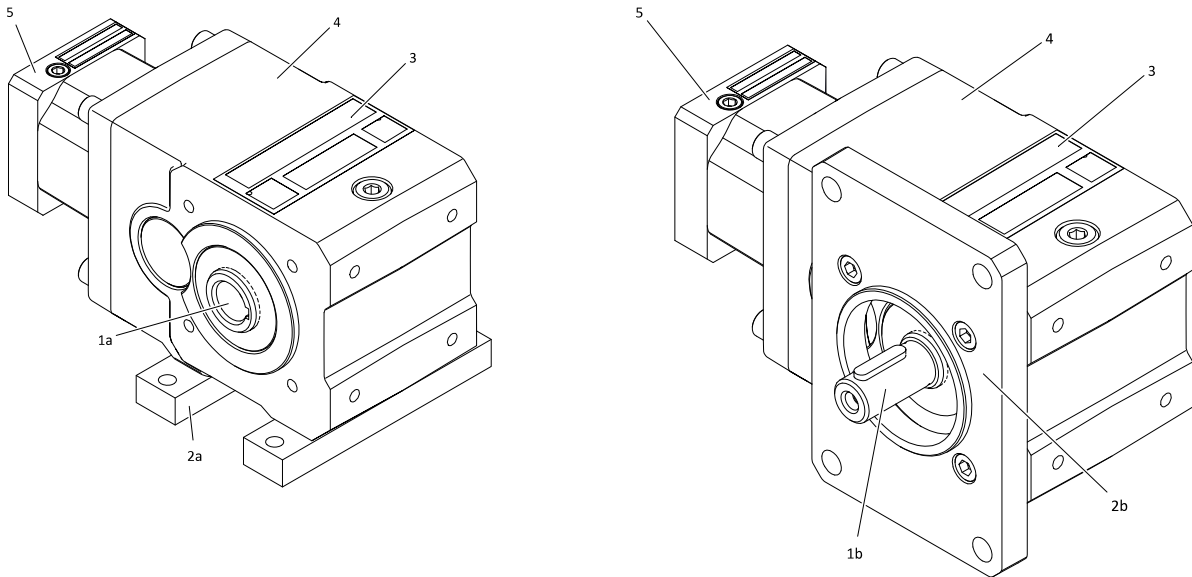

Tab. 1: Basic structure of a KL102ANG gear unit (left) and KL102PF gear unit (right)

1a	Hollow shaft	1b	Solid shaft with feather key
2a	Foot plates (option)	2b	Output flange (option)
3	Nameplate	4	Gear housing
5	MQ motor adapter		

### 3.2 Type designation

In this chapter, you can find an explanation of the type designation for the gear unit types mentioned in the title.

#### Example code

KL	2	0	2	P	G	0080	MQ
----	---	---	---	---	---	------	----

#### Explanation

Code	Designation	Design
KL	Type	Helical bevel gear unit
2	Size	2 (example)
0	Generation	Generation 0
2	Stages	Two-stage



Code	Designation	Design
A	Shaft	Hollow shaft with keyway
S		Hollow shaft with shrink ring
G		Solid shaft without feather key
P		Solid shaft with feather key
G	Housing	Pitch circle diameter
F		Flange
NG		Foot + pitch circle diameter
GD		Pitch circle diameter + torque arm bracket
<b>0080</b>	Transmission ratio (i x 10)	i = 8 (example)
<b>MQ</b>	Motor adapter	Square motor adapter with backlash-free plug-in coupling
EZ	Motor	EZ synchronous servo motor
LM		LM Lean motor

### 3.3 Nameplate

An example gear unit nameplate is explained in the figure below.

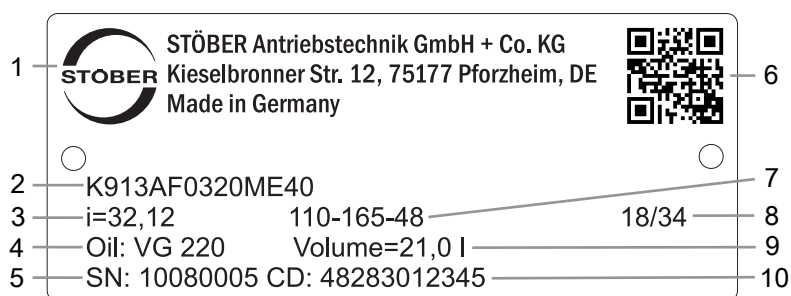

Code	Designation
1	Name of manufacturer
2	Type designation
3	Gear ratio of the gear unit
4	Lubricant specification
5	Serial number of the gear unit
6	QR code (link to product information)
7	Dimensions of the motor adapter (pilot/bolt circle/motor shaft diameter)
8	Date of manufacture (year/calendar week)
9	Lubricant fill volume
10	Customer-specific data

### 3.4 Mounting positions

The KL gear unit can be installed in any mounting position. The figure below illustrates the gear sides referenced by the shaft and housing designs.

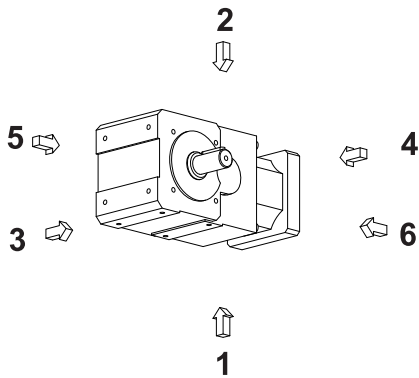

### 3.5 Direction of rotation

Solid shaft (P and G), solid shaft on both sides (P and G), hollow shaft with keyway (A)

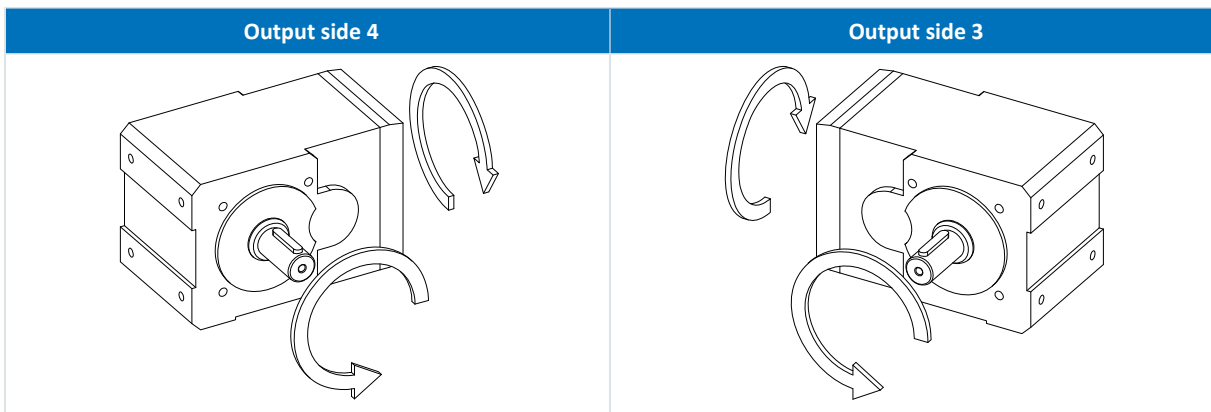

The specified directions of rotation also apply to gear units with hollow shaft (A) if the entry side of the machine shaft corresponds to the side of the solid shaft that is shown.

The direction of rotation for the shaft design of a solid shaft on both sides corresponds to the direction of rotation for output side 4.

The pictures show mounting position EL1.

### Hollow shaft with shrink ring (S)

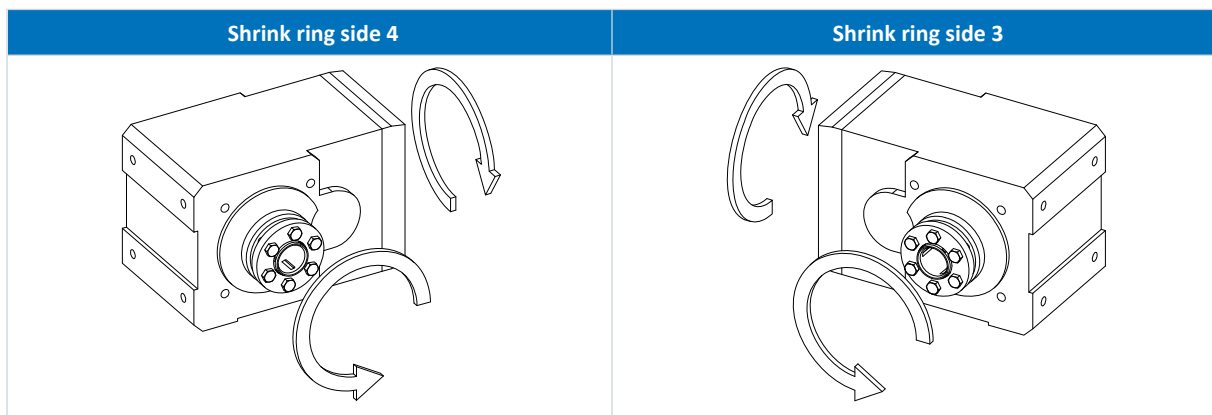

The pictures show mounting position EL1.

## 3.6 Ambient conditions

Standard ambient conditions for transport, storage and operation of the gear unit are described in this chapter. Deviating ambient conditions for special designs are specified in the order confirmation. Ambient conditions for motors attached to a gear unit can be found in the technical documentation of the motor.

Feature	Description
Transport/storage surrounding temperature	-10 °C to +50 °C
Surrounding operating temperature	0 °C to +40 °C
Installation altitude	≤ 1000 m above sea level

### Notes

In order to prevent corrosion damage and damage to the shaft seal rings, protect the drive from the following influences:

- Environments with harmful oils, acids, gases, vapors, dust or radiation
- Extreme temperature fluctuations with high humidity
- Condensation or icing
- Strong UV radiation (e.g. direct sunlight)
- Presence of salt spray
- Sparks

In potentially explosive atmospheres, only gear units in an explosion-proof design in accordance with (ATEX) Directive 2014/34/EU may be used. Separate documentation applies to the explosion-proof design.

## 3.7 Other product features

Other features of gear units in the standard design can be found in the following table.

Feature	Description
Maximum permitted gear unit temperature (on the surface of the gear unit)	$\leq 90$ °C
Paint	Black RAL 9005
Lubricant	Synthetic; for specification and quantity, see nameplate
Ventilation	Gear housing closed on all sides, no ventilation provided
Weight	See order documents
Protection class	IP65

With a geared motor, keep in mind that the motor protection class may be lower.

## 3.8 Additional documentation

You will find more information about the product at <http://www.stoeber.de/en/downloads/>. Enter the ID of the documentation in the Search... field.

Product combination	Catalog title	ID
Gear unit + ME/MEL/MF/MFL motor adapter	Servo gear units	443054_en
Gear unit + EZ synchronous servo motor	EZ synchronous servo geared motors	442437_en
Gear unit + LM Lean motor	Lean motors	443016_en

If you have questions about your drive that are not answered by this documentation, please contact STOBBER Service ([Service \[▶ 30\]](#)).

## 4 Transport and storage

STOBER products are packaged carefully and delivered ready for installation. The type of packaging depends on the product size and the transport method.

Observe the following information during transport and storage:

- Inspect the delivery for any transport damage immediately upon receiving it and report any transport damage immediately. Do not put damaged products into operation.
- Check your delivery for completeness using the delivery note and report any missing parts to the supplier.
- Transport and store the product in the original packaging in order to protect it from damage. Remove the original packaging and transport safety devices shortly before assembly.

### Ambient conditions

The ambient conditions for transport and storage can be found in the chapter [Ambient conditions](#) [► 11].

## 4.1 Transport



### Suspended loads!

Loads that become loose and fall during the lifting process can cause serious injuries or even death!

- Observe the following instructions.
- Cordon off the danger zone and ensure that no one stands under the suspended loads.
- Wear safety shoes.

Lifting and transporting the drive may require lifting gear (e.g. a crane), depending on the weight. The weight of your drive is specified in the accompanying delivery documents.

Lift and transport the drive as follows:

- Use lifting gear with a sufficient lifting capacity for the weight of the drive.
- Run hoist slings directly around the drive housing and secure the hoist slings from slipping.

In order to prevent the drive from falling or getting damaged during transport, observe the following:

- Do not lift or fasten the drive on the output shaft or attached parts.
- Fasten the motor installed on the gear unit as well and make sure that there is no diagonal pull.

## 4.2 Storage

Store the drive in a dry, dust-free environment in the original packaging at a storage temperature between  $-10\text{ °C}$  and  $+50\text{ °C}$ .

## 4.2.1 Long-term storage

If you would like to store the drive for longer than 6 months, take the following steps to prevent corrosion damage:

1. Apply a suitable corrosion protection agent to unpainted surfaces, such as shaft ends or flange contact surfaces.
2. Completely fill the gear unit with lubricant. The lubricant specification can be found by entering the serial number of the gear unit at <https://id.stober.com> or by scanning the QR code on the nameplate of the gear unit.

Before commissioning the gear unit, reduce the lubricant fill volume to the fill volume that is specified on the nameplate of the gear unit.

## 5 Installation

This chapter contains information on how to correctly mount standard STOBBER drive designs and avoid injury to persons or damage to property. Differing information for customer-specific designs is included in the order documents.

Observe the technical documentation of the motor for the assembly and electrical connection of the motor.

Inspect the drive for transport or storage damage. If the drive is damaged, do not install it and contact the STOBBER Service department.

The following tools and equipment are required for mounting the drive:

- If necessary due to the overall weight, lifting gear with appropriate fastening elements and sufficient lifting capacity
- Open-end wrench set
- Socket wrench set
- Long hexagon insert set
- Torque wrench
- Grease
- Cleaning agent or solvent

Information about the specific tools or equipment can be found in the respective chapter.

### 5.1 Cleaning agent and solvent

Upon delivery, unpainted surfaces of the drive are protected by a corrosion protection agent. The corrosion protection agent must be removed from contact surfaces such as shaft ends and flange contact surfaces before assembly. STOBBER recommends removing the corrosion protection with a suitable cold cleaner (e.g. Carlofon Autocleaner) which, in contrast to volatile solvents, is almost odorless and does not weaken the sealing lips of the shaft seal rings. Otherwise, you can use commercially available solvents.

Be aware that all surfaces that come into contact with each other in a clamp connection must be degreased with a cold cleaner or solvent for error-free torque transmission. Additional information can be found in the following chapters.

**ATTENTION! Shaft seal rings can be damaged by solvents!** Prevent shaft seal rings from coming into contact with solvents when cleaning and degreasing unpainted surfaces.

### 5.2 Permitted tilting torques at the gear unit input

If you mount a STOBBER gear unit on the machine in a horizontal mounting position, check that the permitted tilting torque is not exceeded on the gear unit input before mounting the corresponding motor. Information on the permitted tilting torque can be found in the corresponding catalog ([Additional documentation \[► 12\]](#)).

### 5.3 Tolerances for the add-on motor

This chapter describes tolerances for motors that are required for assembly on a STOBBER gear unit with motor adapter. Dimensional drawings of the motor adapter can be found in the corresponding catalog ([Additional documentation \[► 12\]](#)).

#### Tolerances for shafts in accordance with DIN 748-1

Diameter [mm]	Tolerance
≤ 50	ISO k6
> 50	ISO m6

**Tolerances for centering diameter on the motor flange in accordance with EN 50347**

Centering diameter [mm]	Flange size [mm]	Tolerance
≤ 230	65 – 300	ISO j6
> 230	350 – 500	ISO h6

**Tolerances for radial runout, axial runout and concentricity in accordance with IEC 60072-1 (normal class)**

Symbol	Unit	Explanation
kx	μm	Concentricity of the flange centering in relation to the shaft
pl	μm	Axial runout of the flange mounting surface in relation to the shaft
r	μm	Radial runout of the shaft end

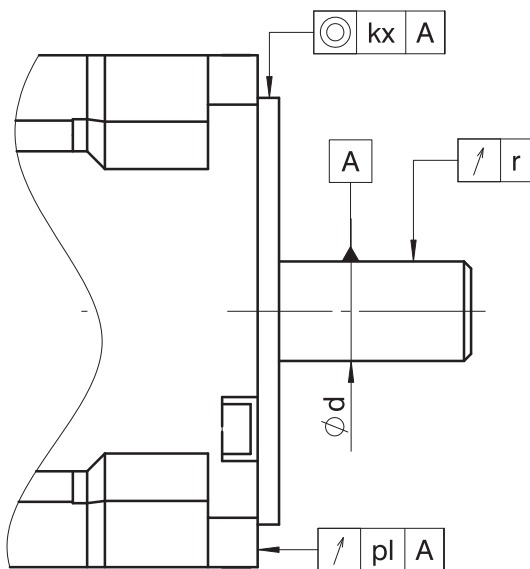

$\phi d$ [mm]	r [μm]
$d \leq 10$	30
$10 < d \leq 18$	35
$18 < d \leq 30$	40
$30 < d \leq 50$	50
$50 < d \leq 80$	60

Centering diameter [mm]	Flange size	kx [μm]	pl [μm]
50 – 95	65 – 115	80	80
110 – 130	130 – 165	100	100
250 – 450	300 – 500	125	125



## 5.4 Mounting the motor on a gear unit

### Prerequisites

- Dimensional tolerances of the motor correspond to the requirements in the chapter [Tolerances for the add-on motor](#) [[▶ 15](#)]
- The permitted tilting torque on the gear unit input is not exceeded (see [Permitted tilting torques at the gear unit input](#) [[▶ 15](#)])
- Four screws of strength class 8.8 are available for mounting the motor on a gear unit. The minimum screw depth for these screws is 1.6x the nominal diameter of the screw
- The necessary tools and aids are available (see [Installation](#) [[▶ 15](#)])
- The information in the chapter [Cleaning agent and solvent](#) [[▶ 15](#)] is observed

### Procedure

1. Position the gear unit with the motor adapter facing upwards so that the motor can be mounted in a vertical position.
2. Remove the transport cover of the motor adapter.
3. If a feather key is installed on the motor shaft, remove it.
4. Remove all corrosion protection from the motor shaft and contact surfaces of the motor and motor adapter.
5. Carefully remove any lubricant from the inner hole of the clamping hub (15) and, if available, the inner and outer surface of the adapter bushing (6) for the motor shaft.
6. Unscrew the screw plug (13).
7. Grease the gear rim (16) and position it between the claws of the coupling hub (15).
8. Position the clamping hub (14) on the coupling hub and make sure that the claws of the clamping hub are positioned between the teeth of the gear rim and the claws of the coupling hub.
9. Turn the clamping hub so that the locking screw (11) can be turned over the bore for the screw plug (13), guide the hexagon insert (3) through the bore and insert it into the hexagon socket of the locking screw.
10. If an adapter bushing (6) is necessary, insert the adapter bushing into the inner hole of the clamping hub (15) as far as it will go and turn the adapter bushing so that the slot of the adapter bushing coincides with the slot of the clamping hub (10).
11. If necessary, use two suitable attachment points to secure the motor with the lifting gear so that the motor shaft is pointing down vertically.
12. Turn the motor in an axial position to the gear unit so that the nameplates are on the same side, if possible, and can also be read after installation in the machine.
13. If the motor shaft has a keyway, position the motor shaft so that the keyway is opposite the slot of the clamping hub (10).
14. Carefully place the motor on the motor adapter (4) and make sure that the motor shaft is inserted (7) in the clamping hub (15) so that it is centered and not at an angle.
15. If the motor shaft cannot be inserted into the clamping hub, do not use force and instead turn the locking screw (11) counterclockwise one quarter rotation with the hexagon insert (3). The size of the hexagon insert can be found on the adhesive label (14) as well as in the following tables.
16. If necessary, repeat the previous step.
17. The contact surfaces of the motor flange and motor adapter flange must fit together without a gap. If this is not the case, do not use force and instead check the dimensions of the motor.

18. Make sure that the flexible gear rim is not tensioned axially when mounting the motor. Otherwise, the plug-in coupling can be damaged.
19. Insert the torque wrench (2) in the hexagon insert (3) and tighten the locking screw (11). The corresponding tightening torque can be found in the following table and on the adhesive label on the motor adapter.
20. Mount the motor on the motor adapter with screws (9). Tighten the screws evenly, with increasing torque and alternating diagonally. The tightening torque can be found in the chapter [Tightening torques](#) [▶ 25].
21. Plug the access hole with the screw plug (13) by screwing it in until it is flush with the surface of the motor adapter.

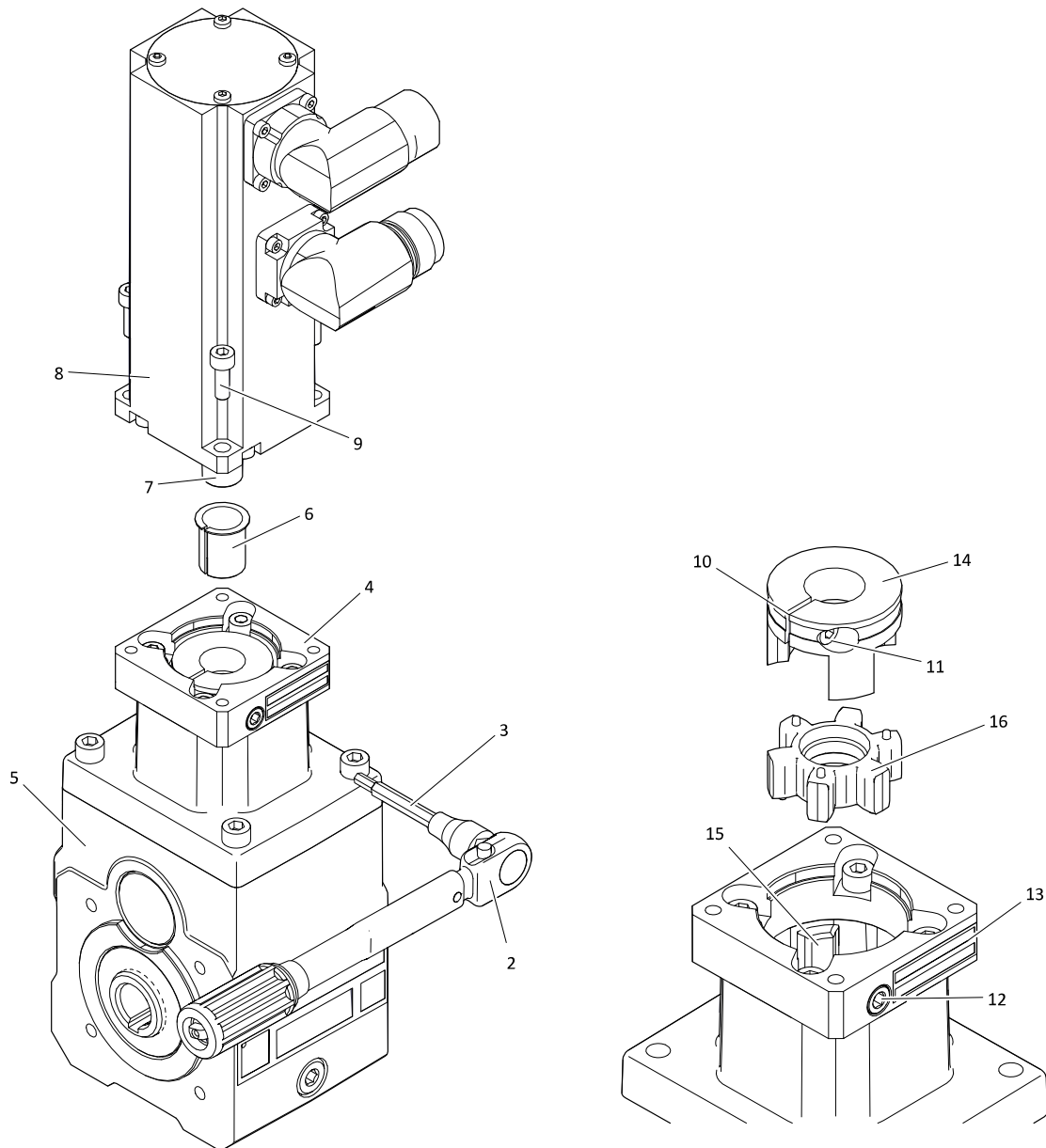

Fig. 1: Mounting a motor on a KL helical bevel gear unit with MQ motor adapter (example)

1	–	2	Torque wrench
3	Hexagon insert	4	Motor adapter
5	Gear unit	6	Adapter bushing (if present)
7	Motor shaft	8	Motor
9	Screw	10	Slot of the clamping hub
11	Locking screw	12	Screw plug

13	Adhesive label	14	Clamping hub
15	Coupling hub	16	Gear rim

### Tightening torques for the locking screw (11)

Type	KS	s	M <sub>A</sub>
		[mm]	[Nm]
KL102	M4	3	2.9
KL202	M6	5	10

Abbreviations used:

- KS = Nominal diameter of the locking screw (11)
- M<sub>A</sub> = Tightening torque for the locking screw (11)
- s = Size of the hexagon insert (3)

## 5.5 Mounting the output shaft

This chapter contains information on how to correctly connect the different designs of the gear unit output shaft with the machine so that the torque can be transmitted properly.

### 5.5.1 Mounting drive elements on a solid shaft

This chapter describes the assembly of drive elements, such as hubs, belt drives, couplings, pinions or sprockets, on the output of a gear unit with a solid shaft and feather key.

When mounting drive elements on a solid shaft without a feather key, observe the technical documentation of the drive element in question.

**ATTENTION! Damage to encoders, bearings and shafts due to improper assembly!** Never use force when mounting drive elements with fittings, e.g. hitting drive elements, shafts or the motor or gear housing with a hammer, and instead install them in accordance with the instructions in the documentation.

#### Prerequisites

- The drive element does not cause any impermissible shaft loads (e.g. tensioning the belt on a belt drive). Information on permissible shaft loads can be found in the corresponding catalog (see [Additional documentation \[▶ 12\]](#));
- The drive element is balanced;
- The tolerance of the inner hole of the drive element is ISO H7;
- The keyway of the drive element corresponds to DIN 6885-1 (if not otherwise specified);
- The information in the chapter [Cleaning agent and solvent \[▶ 15\]](#) is observed
- A mounting device suitable for the drive element is available (not included in the scope of delivery of the gear unit).

#### Procedure

1. Remove the corrosion protection from the solid shaft.
2. Degrease the inner hole of the drive element.
3. Mount the drive element on the solid shaft with the aid of a mounting device positioned on the centering hole of the solid shaft. Details can be found in the following figure and table.
4. If the drive element is difficult to hoist, do not use force and instead heat it to about 80 °C beforehand.

- If the length of the solid shaft is greater than the length of the drive element, use an appropriate spacer bushing that you position between the plate (1) and drive element (5).

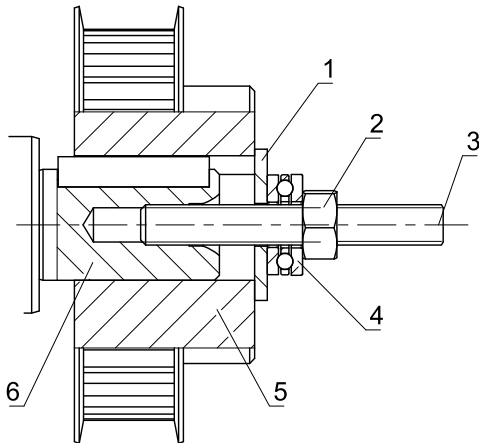

Fig. 2: Mounting device for a belt drive (example)

1	Washer	2	Nut
3	Set screw	4	Axial bearing
5	Belt drive (example)	6	Solid shaft

## 5.5.2 Mounting a hollow shaft with keyway

This chapter describes how to mount gear units with a hollow shaft and keyway on a machine shaft. A keeper plate is integrated in the hollow shaft, with the help of which the hollow shaft can be mounted on and removed from the machine shaft.

The inner hole of the hollow shaft has a spiral-shaped groove. This helps distribute the grease in the inner hole of the hollow shaft and makes mounting and removing the hollow shaft easier.

### Tools

The following tools are required for assembling the hollow shaft (not included in the scope of delivery of the gear unit):

- Cylinder screw for mounting the hollow shaft (size M5 for KL1 gear unit and M6 for KL2 gear unit)
- DIN 125 washer for cylinder screw
- Grease

### Prerequisites

- The information in the chapter [Cleaning agent and solvent \[▶ 15\]](#) is observed
- Length of the machine shaft  $\geq 2.2 \times$  inner diameter of the hollow shaft;
- Length of the feather key  $\geq 2 \times$  inner diameter of the hollow shaft;
- The feather key corresponds to DIN 6885-1.
- The machine shaft has the tolerance of ISO k6 (the inner hole of the hollow shaft has the tolerance of ISO H7).

### Procedure

- Remove the cover of the hollow shaft, if present.
- Remove the corrosion protection from the machine shaft, inner hole of the hollow shaft and other contact surfaces.
- Apply grease to the machine shaft and distribute it evenly.

4. Insert the gear unit with the hollow shaft onto the machine shaft.
5. With the help of the cylinder screw and washer, pull the gear unit onto the machine shaft up to the stop, which is determined by the collar of the machine shaft, the keeper plate or the output flange.
6. If the length of the centering hole in the machine shaft is not sufficient, unscrew the cylinder screw again and position a spacer bushing of the corresponding length between the cylinder screw and washer. Repeat the previous step.
7. Unscrew the cylinder screw from the centering hole.

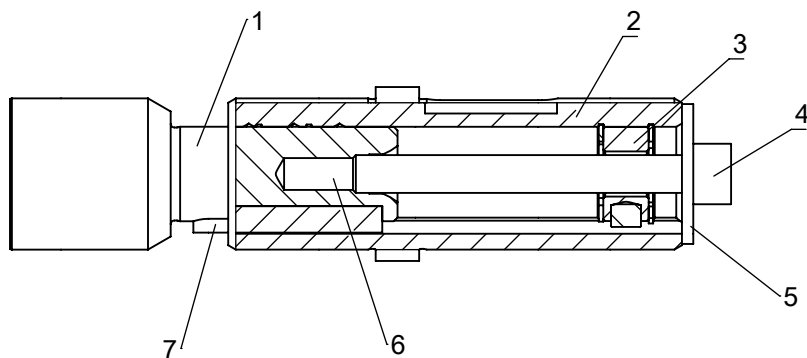

1	Feather key	2	Hollow shaft
3	Cylinder screw (not in the scope of delivery)	4	Washer (not in the scope of delivery)
5	Keeper plate	6	Centering hole
7	Machine shaft		

### 5.5.3 Mounting a hollow shaft with shrink ring

This chapter describes how to mount gear units with a hollow shaft and shrink ring on a machine shaft.

#### Prerequisites

- Material of the machine shaft has a permitted surface pressure  $p \geq 325 \text{ N/mm}^2$ . This specification applies to solid shafts. If the machine shaft is a hollow shaft, consult STÖBER in order to avoid deformation of the machine shaft due to the shrink ring.
- The information in the chapter [Cleaning agent and solvent](#) [▶ 15] is observed
- The machine shaft has the tolerance of ISO h6 (the inner hole of the hollow shaft has the tolerance of ISO H7).

#### Procedure

**ATTENTION! Property damage!** Only tighten the clamping screws of the shrink ring after you have inserted the gear unit onto the machine shaft. Otherwise, the hollow shaft can be plastically deformed.

1. Remove the closing and cover caps from the hollow shaft and shrink ring.
2. Remove the corrosion protection from the machine shaft (2), the bore of the hollow shaft (3) and shrink ring (4) and other contact surfaces.
3. Carefully degrease the machine shaft in the press area of the shrink ring 7 and the hollow shaft, inside and out, in the press area 8 such that the torque can be transferred completely.
4. Apply grease to the machine shaft in the contact area 6 with the bush.
5. Insert the gear unit with the hollow shaft onto the machine shaft.
6. If the hollow shaft is slitted in the press area, position the shrink ring at a distance  $f_s$  from the end of the hollow shaft (see the following figure and table). Otherwise, position the shrink ring at the stop on the collar of the hollow shaft.

- Tighten the clamping screws of the shrink ring evenly in several cycles by one quarter rotation each in turn (not alternating diagonally) up to the specified tightening torque (see the following table). When tightening the clamping screws, make sure that the clamping plates of the shrink ring remain plane-parallel to each other and do not touch.

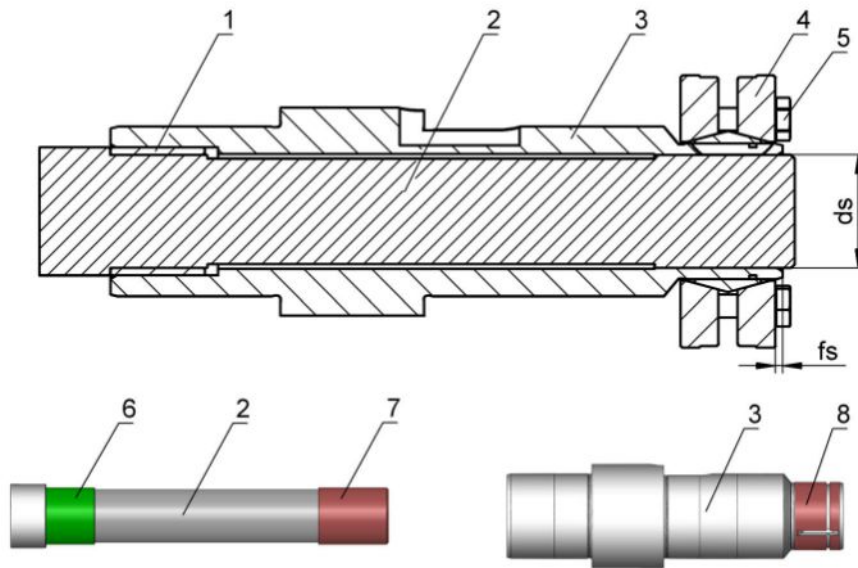

- |   |                         |   |                                         |
|---|-------------------------|---|-----------------------------------------|
| 1 | Socket                  | 2 | Machine shaft                           |
| 3 | Hollow shaft            | 4 | Shrink ring                             |
| 5 | Clamping screw          | 6 | Surface, greased                        |
| 7 | Surface, free of grease | 8 | Inner and outer surface, free of grease |

**Information on mounting the shrink ring**

Gear unit type	fs	ds [mm]	M <sub>a</sub> [Nm]	Width across flats [mm]
KL1	–	16	4	8
KL2	2	20	5	8

Abbreviations used:

- ds = Inner diameter of the shrink ring
- fs = Distance between end of hollow shaft and shrink ring
- M<sub>a</sub> = Tightening torque of the clamping screws

## 5.6 Mounting the gear unit on the machine

Depending on the design, the KL gear unit can be mounted on the machine via the pitch circle diameter, output flange or foot plates.

**Prerequisites**

- The connecting structure for the drive in the machine is dimensioned according to the weight and torque and takes forces that act on the drive into account;
- The connecting structure is flat, vibration-reducing and torsion-resistant;

The perpendicularity deviation of the flange contact surface of the connecting structure to the gear unit shaft axis does not exceed 0.03 mm per 100 mm;

- The gear housing is grounded via the connecting structure or attached motor;
- The tolerance of the centering diameter of the connecting structure is ISO H7;
- Sufficient ventilation for the mounted drive is ensured.

### Procedure

1. Remove the corrosion protection from the contact surfaces of the pitch circle diameter/output flange/foot plates and from the connecting structure.
2. For a gear unit with a hollow shaft and keyway, mount the hollow shaft on the machine shaft (see [Mounting a hollow shaft with keyway](#) [▶ 20]).
3. For a gear unit with a hollow shaft and shrink ring, mount the hollow shaft to the machine shaft (see [Mounting a hollow shaft with shrink ring](#) [▶ 21]), but do not yet tighten the clamping screws of the shrink ring.
4. Position the gear unit in the specified mounting position.
5. Center the gear unit in the connecting structure using the pilot of the gear housing or output flange. Centering is not necessary for attachment using foot plates.
6. Mount the gear unit on the connecting structure using screws. Details on the screws can be found in the following table.
7. Tighten the screws evenly in multiple passes with increasing torque and alternating diagonally. The tightening torques can be found in the chapter [Tightening torques](#) [▶ 25].
8. Tighten the clamping screws for the gear unit with hollow shaft and shrink ring (see [Mounting a hollow shaft with shrink ring](#) [▶ 21]).

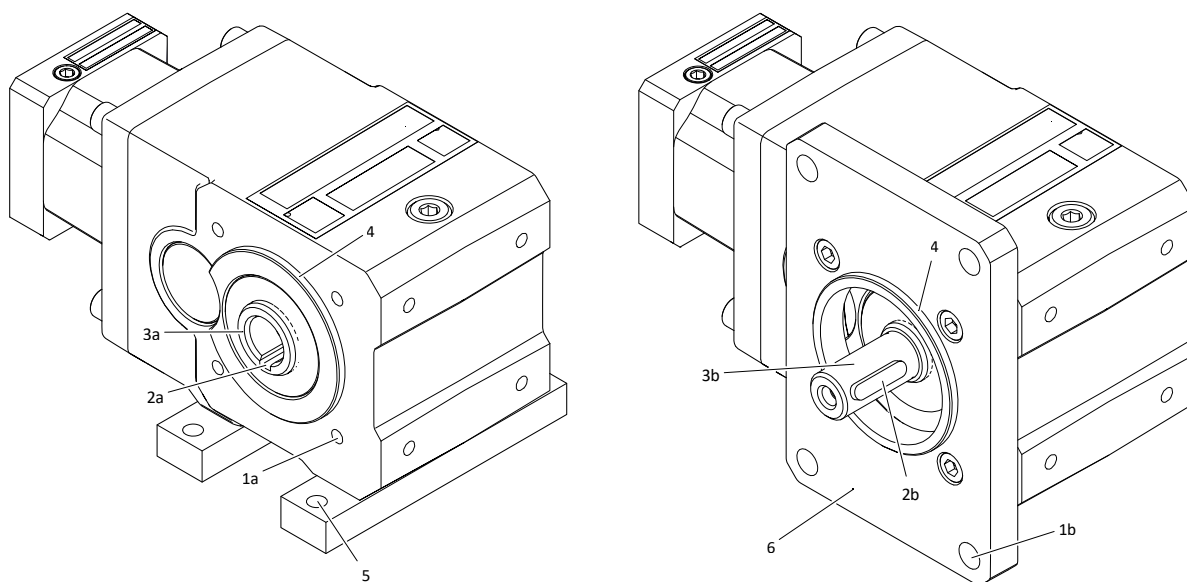

Tab. 2: Mounting a gear unit with foot plates (left) and a gear unit with output flange (right)

1a	Threaded hole in the housing	1b	Output flange bore (option)
2a	Keyway of the hollow shaft	2b	Feather key
3a	Hollow shaft	3b	Solid shaft
4	Housing pilot	5	Bore of the foot plate (option)
6	Output flange		

Gear unit type	Number of screws	Screw size	Min. screw-in depth [mm]	Strength class
KL102_G	4	M6	11	10.9
KL202_G	4	M6	11	10.9
KL102_F	4	M8	–	10.9
KL202_F	4	M8	–	10.9
KL102_NG	4	M6	–	10.9
KL202_NG	4	M6	–	10.9

Tab. 3: Information on screws for mounting the gear housing on the machine

## 5.6.1 Mounting the torque arm bracket

For gear units with a hollow shaft attached to the machine shaft, the torque arm bracket absorbs the reaction torque. The torque arm bracket can be mounted on different gear unit sides and different positions.

### Prerequisites

- You mounted the hollow shaft on the machine shaft.
- You mounted the gear unit to the machine such that the weight of the gear unit is absorbed by the pitch circle diameter, output flange or foot plate.

### Procedure

Observe the following when mounting the torque arm bracket:

- Mount the torque arm bracket so that the bush (13) of the torque arm bracket is positioned on the side where the machine shaft (7) is connected. This prevents additional bending stress.
- Support the bush of the torque arm bracket from both sides; otherwise, too much load is put on it during operation.
- Mount the torque arm bracket without tension to ensure that the gear unit is not under additional load.
- Prevent the bushes from making contact with solvents, oils and greases, as otherwise they may be damaged.



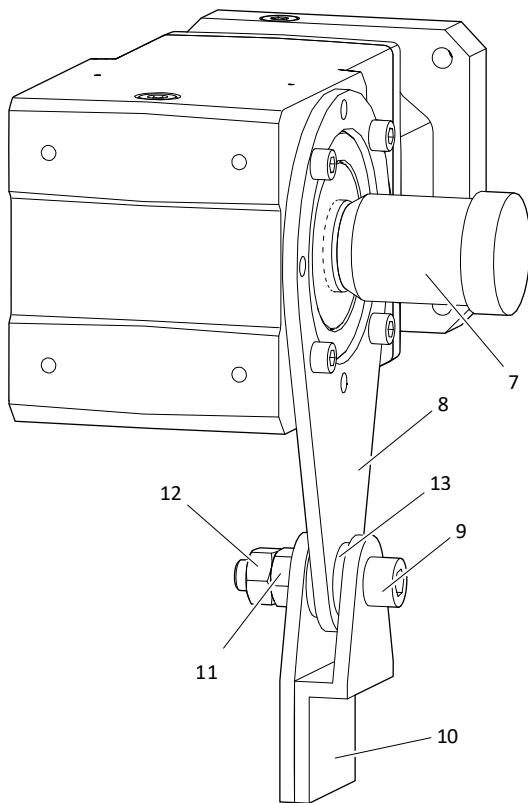

Tab. 4: Mounting a KL202\_AGD gear unit (example)

7	Machine shaft <sup>1</sup>	8	Torque arm bracket
9	Hex head screw <sup>1</sup>	10	Bearing <sup>1</sup>
11	Hex nut <sup>1</sup>	12	Locking nut <sup>1</sup>
13	Bush		

<sup>1</sup> These mounting elements are not included in the scope of delivery of the gear unit.

## 5.7 Tightening torques

Note that the following tightening torques apply to screws that are used for mounting the motor on the gear unit or the gear unit on the machine. For clamp couplings, clamping screws of shrink rings and other connection elements, other tightening torques apply that are specified in the specific context.

Thread	Tightening torque $M_A$ [Nm]		
	Strength class 8.8	Strength class 10.9	Strength class 12.9
M4	3.3	4.8	5.6
M5	6.5	9.5	11.2
M6	11.3	16.5	19.3
M8	27.3	40.1	46.9
M10	54	79	93
M12	93	137	160
M14	148	218	255
M16	230	338	395
M18	329	469	549

Thread	Tightening torque $M_A$ [Nm]		
	Strength class 8.8	Strength class 10.9	Strength class 12.9
M20	464	661	773
M22	634	904	1057
M24	798	1136	1329
M27	1176	1674	1959
M30	1597	2274	2662
M36	2778	3957	4631

Tab. 5: Tightening torques for screws with metric standard thread in accordance with DIN 13-1 (coefficient of friction  $\mu_{ges} = 0.14$ ).

## 6 Commissioning

### 6.1 Before commissioning

**WARNING! Moving machine parts can cause serious injuries or even death!** Before performing work, switch off the machine with the main switch and secure the switch from being turned on again.

Before commissioning the drive, make sure that the following prerequisites are met:

- The drive is undamaged
- The mechanical assembly and electrical connection of the drive has been completed
- The drive is not blocked
- Any present feather keys are secured against being thrown for a test run with drive elements
- All protective devices have been properly mounted
- All monitoring equipment is activated
- The drive controller is adjusted so that an overload of the gear unit in relation to the permitted torque is prevented by the motor
- The ambient conditions are observed (see [Ambient conditions \[► 11\]](#))

### 6.2 During commissioning

**WARNING! Moving machine parts can cause serious injuries or even death!** Make sure that no one is standing in the danger area or able to enter it unchecked.

**WARNING! Falling gravity-loaded axes or vertical axes can cause serious injuries or even death!** Move gravity-loaded axes or vertical axes to their lowest position and lock or brace them mechanically before entering the danger area.

**WARNING! If the motor is in operation while plug connectors are being disconnected, electric arcs can cause severe injury or even death.** Do not connect or disconnect the plug connectors until after the motor is de-energized.

**WARNING! Flying metal parts can cause serious injuries!** Assemble the provided power transmission elements properly or remove the feather key before a test run.

**CAUTION! The surface of the drive can reach temperatures over 65 °C during operation!** Allow the drive to cool sufficiently before working on it. Wear gloves.

During commissioning, check the following:

- After the any existing brakes released before starting the drive?
- Is the direction of rotation of the drive correct?
- When the drive is running, do any overloading, unwanted speed fluctuations, unusual noises or vibrations occur?

In case of faults, observe the chapter [Troubleshooting faults \[► 29\]](#).

#### Measurement of the surface temperature

For safe operation, it must be ensured that the surface temperature of the gear unit does not exceed the maximum permitted value. For this purpose, perform measurements with a commercially available temperature measuring device. Determine the surface temperature at the transition between gear unit and motor adapter or between gear unit and motor.

The maximum surface temperature occurs in approx. 3 hours, depending on the utilization of the drive, and must not exceed the maximum value of 90 °C in the event of a maximum surrounding temperature. Immediately shutdown the drive if the maximum value is exceeded and contact STOBBER Service.

# 7 Servicing

## 7.1 Cleaning

If the surface of the drive is dirty, heat dissipation through the ambient air is no longer sufficient. As a result, impermissibly high operating temperatures that reduce the lubricating effect of the lubricant and accelerate its aging could occur. This has a negative effect on the service life of the drive. Furthermore, the thermal winding protection may force the drive to shut down the drive has reached its nominal values.

Determine the cleaning interval according to the expected operating conditions, but it should be every 12 months at the latest. Clean the drive according to the following instructions.

**WARNING! Moving machine parts can cause serious injuries or even death!** Before performing work, switch off the machine with the main switch and secure the switch from being turned on again.

**WARNING! Falling gravity-loaded axes or vertical axes can cause serious injuries or even death!** Move gravity-loaded axes or vertical axes to their lowest position and lock or brace them mechanically before entering the danger area.

**CAUTION! The surface of the drive can reach temperatures over 65 °C during operation!** Allow the drive to cool sufficiently before working on it. Wear gloves.

**ATTENTION! Improper cleaning can cause damage to the gear unit/geared motor!** Do not use steam jet cleaners, high-pressure cleaners or compressed air to clean the gear unit/geared motor, as this can result in water and dirt entering the interior of the gear unit/geared motor through the seals and can damage it. In addition, do not use solvents, as these can damage the seals and the nameplate. Comply with the following instructions.

- Remove dust and chips with a suitable industrial vacuum.
- Remove contamination from the surface of the drive with a suitable industrial cleaner.

## 7.2 Inspection

Perform regular inspections on the gear unit in accordance with the following specifications. Inspect the attached motor in accordance with the documentation of the motor manufacturer.

**WARNING! Moving machine parts can cause serious injuries or even death!** Before performing work, switch off the machine with the main switch and secure the switch from being turned on again.

**WARNING! Falling gravity-loaded axes or vertical axes can cause serious injuries or even death!** Move gravity-loaded axes or vertical axes to their lowest position and lock or brace them mechanically before entering the danger area.

**CAUTION! The surface of the drive can reach temperatures over 65 °C during operation!** Allow the drive to cool sufficiently before working on it. Wear gloves.

The gear units are filled with synthetic lubricant at the factory. With intended use, the lubricant does not need to be changed over the entire service life of the gear unit. The specification and fill volume of the lubricant is specified on the nameplate of the gear unit.

Interval	Task
Every 3000 operating hours or every 6 months	Check shaft seal rings for external damage and leaks
Annually	Check paint for damage and touch up if necessary
	Check tightening torques of the screw connections between gear unit/machine and between gear shaft/drive elements (see the chapter <a href="#">Tightening torques</a> )

## 7.3 Remediating faults

**WARNING! Moving machine parts can cause serious injuries or even death!** Before performing work, switch off the machine with the main switch and secure the switch from being turned on again.

Notify all personnel working on the machine or the drive of deviations from normal operation. These deviations indicate that the function of the drive is impaired. These include:

- Higher operating temperatures or increased vibrations
- Unusual noises or smells
- Triggering of monitoring systems
- Leaks on the housing of the gear unit

In such an event, shut down the drive and notify the responsible service personnel immediately.

### 7.3.1 Troubleshooting faults

The following table describes faults that can occur during the operation of the gear unit. Read through the table from top to bottom when troubleshooting faults.

Faults	Possible causes	Actions
Operating temperature is higher or exceeds the permitted temperature of the gear unit	Speed or torque is too high	Check the design of the gear unit
	Motor heats the gear unit (too much)	Cool the motor sufficiently
		Check the wiring of the motor
		Replace the motor
	Surrounding temperature is too high	Provide sufficient cooling for the gear unit
Bearing damage	Contact STOBBER Service	
Increased or different noises or vibrations in operation	Motor is mounted with too much tension	Check the assembly of the motor
	Gear unit is mounted incorrectly or with too much tension	Check the assembly of the gear unit
	Bearing damage	Contact STOBBER Service
	Gear damage	Contact STOBBER Service
Leaks	Radial shaft seal ring leaks	Contact STOBBER Service
	Output shaft damaged at the sealing point	Contact STOBBER Service
	Increased inner pressure due to operating temperature that is too high	See measures in case of fault <a href="#">Operating temperature is higher ... of the gear unit</a>
	Gear housing leaks	Contact STOBBER Service
Output shaft does not turn although motor is running	Clamp coupling is defective or tightened incorrectly	Check the clamp coupling

## 7.4 Servicing

Have the necessary servicing work carried out on the drive by the STOBBER Service department or by STOBBER service partners. Be aware that improper servicing may cause material damage and may void the manufacturer's warranty.

Only use replacement parts delivered by STOBBER. Specify the type designation and serial number of the drive when ordering replacement parts. These can be found on the nameplate of the drive.

## 7.5 Service

If you contact STÖBER Service, have the following information ready:

- Serial number and type designation of the drive according to the nameplate
- Type of fault and surrounding circumstances
- Presumed cause
- If possible, digital photo of the drive or a video recording of the drive in the context of the fault

### **Contact data of parent company in Germany**

STÖBER Antriebstechnik GmbH + Co. KG

Kieselbronner Strasse 12

75177 Pforzheim

Germany

Service hotline: +49 7231 582-3000

mail@stoerber.de

### **Contact data of subsidiary in US**

STÖBER Drives Inc.

1781 Downing Drive

Maysville, KY 41056

Service Hotline +1 606 563-6035

service@stoerber.com

## 8 Removal and disposal

### 8.1 Removal

Remove the drive as follows:

1. If the drive had been in operation immediately beforehand, allow it to cool.
2. Disconnect the connection cable and the grounding conductor from the motor.
3. For gear units with a solid shaft: If necessary, remove drive elements connected to the solid shaft, such as belts, chains or couplings, with suitable removal devices.
4. Unscrew the screws used to mount the drive to the machine.
5. For gear units with a hollow shaft and shrink ring: Unscrew the clamping screws of the shrink ring in multiple cycles by one quarter rotation each in turn, but do not completely remove the clamping screws from the thread. Remove the gear unit from the machine shaft.
6. For gear units with a hollow shaft and keyway: Remove the hollow shaft from the machine shaft (see chapter ).
7. Detach the gear unit from the machine.
8. If necessary, remove the motor from the gear unit. To do so, unscrew the screws of the motor used to mount the motor to the gear unit and detach the motor from the gear unit.

#### 8.1.1 Removing a hollow shaft with keyway

This chapter contains instructions for removing the KL gear unit with a hollow shaft and keyway from the machine shaft.

##### Tools

The following tools, not included in the scope of delivery of the gear unit, are required for removal:

- Set screw for removing the hollow shaft (size M6 for KL1 gear unit and M8 for KL2 gear unit)

##### Procedure

1. Screw the parallel pin into the threaded hole of the keeper plate with a hex wrench until the parallel pin presses against the machine shaft.
2. Tighten the parallel pin until the hollow shaft releases from the machine shaft.
3. Detach the gear unit from the machine.
4. Unscrew the parallel pin back out of the threaded hole of the keeper plate.

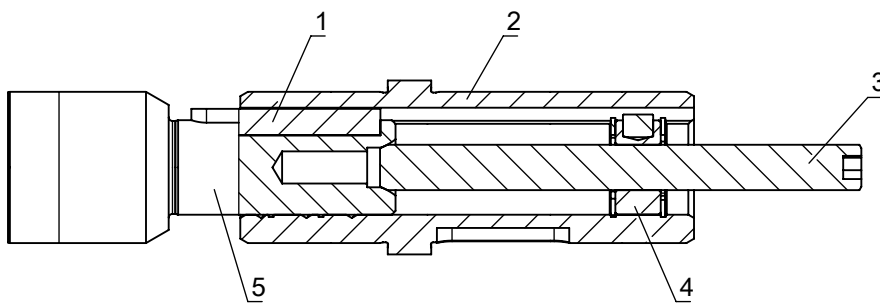

1	Feather key	2	Hollow shaft
3	Set screw (not in the scope of delivery)	4	Keeper plate
5	Machine shaft		

## 8.2 Disposal

Dispose of the component parts of the gear unit according to applicable national regulations and when doing so, observe the following information:

- If possible, separate the gear unit into component parts made of steel/cast iron, aluminum and plastic.
- The gear unit contains lubricants (oil or grease) that pose a risk to the environment and to health. Collect the used oil and grease without mixing them and dispose of them properly.





443363\_en.00

07/2023

STÖBER Antriebstechnik GmbH + Co. KG  
Kieselbronner Str. 12  
75177 Pforzheim  
Germany  
Tel. +49 7231 582-0  
mail@stoeber.de  
www.stober.com

24 h Service Hotline  
+49 7231 582-3000

[www.stober.com](http://www.stober.com)