

# K1 – K10 gear units, geared motors

## Operating manual

en-US  
07/2023  
ID 443364\_en.00

# Table of contents

<b>1</b>	<b>User information</b>	<b>4</b>
1.1	Storage and transfer	4
1.2	Original language	4
1.3	Formatting conventions	4
1.4	Terms	5
1.5	Supporting documents	5
1.6	Limitation of liability	5
1.7	Product names and brands	5
1.8	Copyright notice	5
<b>2</b>	<b>General safety instructions</b>	<b>6</b>
2.1	Intended use	6
2.2	Requirements for personnel	6
2.3	Prevention of personal injury	6
2.3.1	Mechanical hazards	6
2.3.2	Thermal hazards	7
2.4	Prevention of property damage	7
<b>3</b>	<b>Product description</b>	<b>8</b>
3.1	Basic structure	8
3.2	Type designation	9
3.3	Nameplate	10
3.4	Mounting positions	11
3.5	Direction of rotation	12
3.6	Ambient conditions	14
3.7	Other product features	15
3.8	Additional documentation	15
<b>4</b>	<b>Transport and storage</b>	<b>16</b>
4.1	Transport	16
4.2	Storage	16
4.2.1	Long-term storage	17
<b>5</b>	<b>Installation</b>	<b>18</b>
5.1	Cleaning agent and solvent	18
5.2	Mounting the motor on a gear unit	18
5.2.1	Permitted tilting torques at the gear unit input	19
5.2.2	Tolerances for the add-on motor	19
5.2.3	Mounting the motor on a gear unit with ME adapter	20

---

5.2.4	Mounting the motor on a gear unit with MQ/MR adapter with curved tooth coupling.....	23
5.2.5	Mounting the motor on a gear unit with MQ/MR adapter with plug-in coupling .....	25
5.2.6	Mounting the motor on a gear unit with MB adapter.....	27
5.3	Mounting the output shaft.....	27
5.3.1	Mounting drive elements on a solid shaft .....	27
5.3.2	Mounting a hollow shaft with keyway.....	28
5.3.3	Mounting a hollow shaft with shrink ring.....	29
5.4	Mounting the gear unit on the machine .....	31
5.4.1	Mounting the torque arm bracket.....	33
5.5	Tightening torques .....	35
<b>6</b>	<b>Commissioning.....</b>	<b>36</b>
6.1	Before commissioning .....	36
6.2	During commissioning .....	36
<b>7</b>	<b>Servicing .....</b>	<b>37</b>
7.1	Cleaning.....	37
7.2	Inspection.....	37
7.2.1	Changing the oil.....	38
7.3	Remedying faults.....	40
7.3.1	Troubleshooting faults.....	40
7.4	Servicing .....	40
7.5	Service .....	41
<b>8</b>	<b>Removal and disposal.....</b>	<b>42</b>
8.1	Removal.....	42
8.1.1	Removing a hollow shaft with keyway .....	42
8.2	Disposal .....	43

# 1 User information

This documentation is a part of the product. It applies to products in the standard design according to the corresponding STOBER catalog.

## 1.1 Storage and transfer

As this documentation contains important information for handling the product safely and efficiently, it must be stored in the immediate vicinity of the product until product disposal and be accessible to qualified personnel at all times.

Also pass on this documentation if the product is transferred or sold to a third party.

## 1.2 Original language

The original language of this documentation is German; all other language versions are derived from the original language.

## 1.3 Formatting conventions

Orientation guides in the form of signal words are used to emphasize specific information so that you are able identify it in this documentation quickly.

Safety notes indicate special risks when handling the product and are accompanied by relevant signal words that express the extent of the risk. In addition, warning notes for possible property damage and useful information are also indicated by signal words.

---

### **WARNING!**

#### **Warning**

This word with a warning triangle means there may be a considerable risk of fatal injury

- if the stated precautionary measures are not taken.
- 

---

### **CAUTION!**

#### **Caution**

This word with a warning triangle indicates that minor personal injury may occur

- if the stated precautionary measures are not taken.
- 

---

### **ATTENTION!**

#### **Attention**

This indicates that damage to property may occur

- if the stated precautionary measures are not taken.
- 

---

### **Information**

Information indicates important information about the product or serves to emphasize a section in the documentation that deserves special attention from the reader.

---

## Embedded warning information

Embedded warning information is integrated directly into the instruction manual and is structured as follows:

**SIGNAL WORD! Type of hazard, its cause and possible consequences of disregarding it!** Measures for avoiding the hazard.

Signal words in embedded warning information have the same meaning as in the normal warning information described previously.

## 1.4 Terms

This documentation describes both STOBBER gear units and gear components of STOBBER geared motors. For reasons of clarity, the collective term drives is used for these.

## 1.5 Supporting documents

Separate documents apply to the drive components which can be attached to STOBBER gear units, depending on the design. These documents can be found by entering the serial number of the drive at <https://id.stober.com> or by scanning the QR code on the nameplate of the drive.

Alternatively, you can find supporting documents at <http://www.stoeber.de/en/downloads/>. Enter the ID of the documentation in the Search... field:

Drive components	Operating manual ID
LM Lean motor	443048_en
EZ synchronous servo motor	443032_en
MB motor adapter with brake	443287_en
Asynchronous motors	442577_en

## 1.6 Limitation of liability

This documentation was created taking into account the applicable standards and regulations as well as the current state of technology.

No warranty or liability claims for damage shall result from failure to comply with the documentation or from use that deviates from the intended use of the product. This is especially true for damage caused by individual technical modifications to the product or the project configuration and operation of the product by unqualified personnel.

## 1.7 Product names and brands

Product names that are registered as brands are not specifically identified in this documentation. Existing property rights (patents, trademarks, protection of utility models) are to be observed.

## 1.8 Copyright notice

Copyright © STOBBER. All rights reserved.

## 2 General safety instructions

There are risks associated with the product described in this documentation that can be prevented by complying with the described warning and safety instructions as well as the included technical rules and regulations.

### 2.1 Intended use

The drives described in this documentation are intended for installation in industrial machines or systems.

The following are considered non-intended use:

- Any overloading of the drives
- Operation in ambient conditions that deviate from those described in the corresponding technical documentation
- Modifying or refitting the drives
- Using the drives for an application other than that defined during project configuration

Commissioning the machine in which the drives are installed is prohibited until it has been determined that the machine corresponds to regional laws and guidelines. In particular, the (Machinery) Directive 2006/42/EC is to be observed in the respective scope.

Operation of the drives in potentially explosive atmospheres is prohibited, unless they are expressly designed for this.

### 2.2 Requirements for personnel

All mechanical tasks that arise during the assembly, commissioning, maintenance and removal of the product may be performed only by specialized personnel who hold a corresponding qualification in the field of metal technology.

All electrical tasks that arise during the assembly, commissioning, maintenance and removal of the product may be performed only by electrically skilled persons who hold a corresponding qualification in the field of electrical engineering.

Tasks that arise during transport, storage and disposal may be performed by personnel who have been instructed in the suitable method for doing so.

Furthermore, personnel who handle the product must carefully read, understand and observe the valid regulations, legal requirements and applicable basic rules as well as this documentation and the safety instructions it contains.

### 2.3 Prevention of personal injury

#### 2.3.1 Mechanical hazards



#### **Dangerous movements of machine parts!**

Moving machine parts can cause serious injuries or even death!

- ✓ Before starting the motor or drive:
    - Install all protective devices necessary for operation.
    - Make sure that no one is standing in the danger area or able to enter it unchecked.
    - Leave the danger area.
-

---

**⚠ WARNING!****Sinking or falling of gravity-loaded axes or vertical axes after switching off the motor due to gravity!**

Falling gravity-loaded axes or vertical axes can cause serious injuries or even death!

- Be aware that the holding brake of the motor does not offer sufficient safety for persons that are in the hazard area of gravity-loaded axes or vertical axes.
  - Move gravity-loaded axes or vertical axes to their lowest position and lock or brace them mechanically before allowing people to enter the danger area.
- 

**⚠ WARNING!****Unsecured feather keys or drive elements can be thrown due to the rotation of the input shaft!**

Flying metal parts can cause serious injuries!

- Mount the provided drive elements properly or remove them before a test run.
- 

## 2.3.2 Thermal hazards

**⚠ CAUTION!****The surface of the drive can reach temperatures over 65 °C during operation!**

Touching the hot surface of the drive can cause severe skin burns!

- Do not touch the drive during operation or immediately afterward.
  - Allow the drive to cool sufficiently before carrying out work on the drive.
  - Wear protective gloves when working on the drive.
- 

## 2.4 Prevention of property damage

**ATTENTION! Damage to bearings and shafts due to improper assembly!** Never use force when installing machine elements with fittings, e.g. hitting power transmission elements, shafts or the motor or gear housing with a hammer, but rather install them in accordance with the following instructions.

**ATTENTION! Shaft seal rings can be damaged by solvents!** Prevent shaft seal rings from coming into contact with solvents when cleaning and degreasing unpainted surfaces.

## 3 Product description

In this chapter, you will find product details that are relevant for assembly, commissioning and servicing. Detailed technical data on your drive can be found in the order confirmation. You will find more product information and dimensional drawings in the corresponding catalog ([Additional documentation](#) ▶ 15). The respective separate technical documentation applies to attached motors.

### 3.1 Basic structure

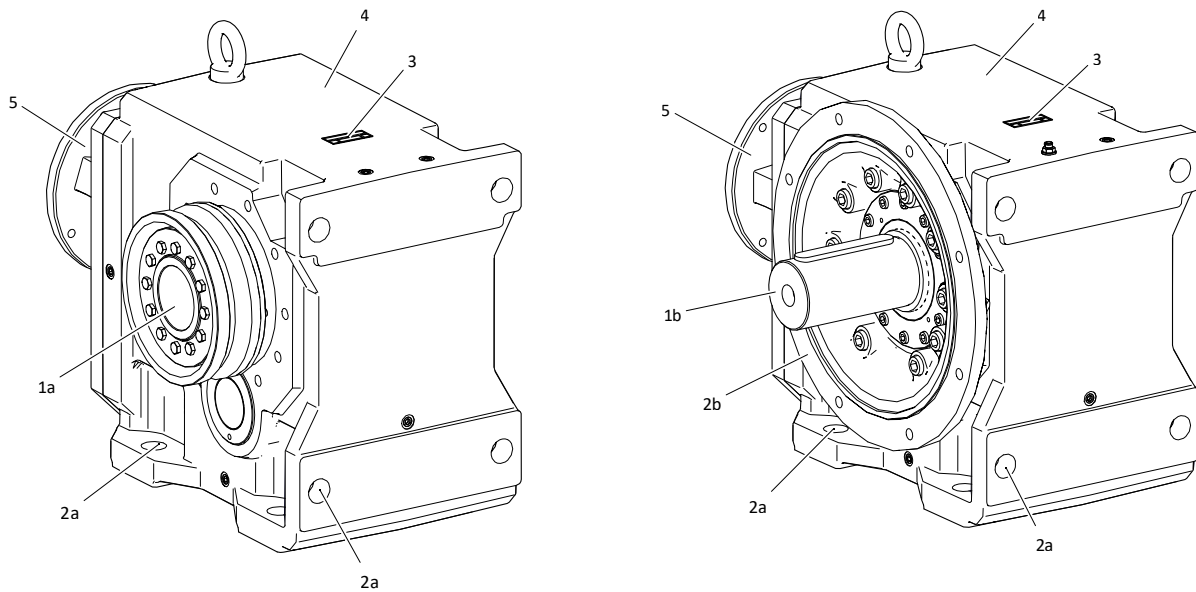

Tab. 1: Basic structure of a K1013SG gear unit (left) and K1013VNF gear unit (right)

1a	Hollow shaft with shrink ring	1b	Solid shaft with feather key
2a	Foot mount	2b	Round flange
3	Nameplate	4	Gear housing
5	MR motor adapter		



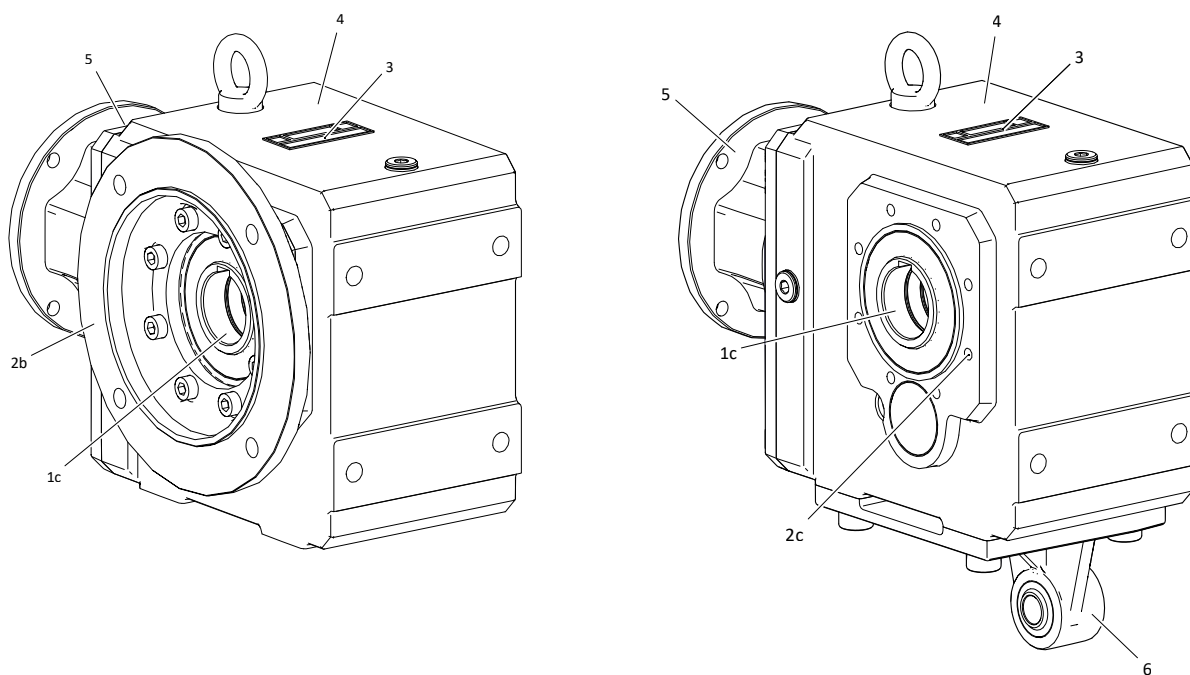

Tab. 2: Basic structure of a K513AF gear unit (left) and K513AGD gear unit (right)

1c	Hollow shaft	2b	Round flange
2c	Pitch circle diameter	3	Nameplate
4	Gear housing	5	MR motor adapter
6	Torque arm bracket		

## 3.2 Type designation

In this chapter, you will find an explanation of the type designation with the associated options.

### Example code

<b>K</b>	<b>4</b>	<b>0</b>	<b>2</b>	<b>A</b>	<b>G</b>	<b>0560</b>	<b>ME20</b>
----------	----------	----------	----------	----------	----------	-------------	-------------

### Explanation

Code	Designation	Design
<b>K</b>	Type	Helical bevel gear unit
<b>4</b>	Size	4 (example)
<b>0</b>	Generation	Generation 0
<b>1</b>		Generation 1
<b>2</b>	Stages	Two-stage
<b>3</b>		Three-stage
<b>4</b>		Four-stage
<b>A</b>	Shaft	Hollow shaft with keyway
<b>S</b>		Hollow shaft with shrink ring
<b>V</b>		Solid shaft

Code	Designation	Design
G	Housing	Pitch circle diameter
F		Round flange
NG		Foot + pitch circle diameter
NF		Foot + round flange
GD		Pitch circle diameter + torque arm bracket
NGD		Foot + pitch circle diameter + torque arm bracket
0560	Transmission ratio (i x 10 rounded)	i = 55.71 (example)
ME20	Motor adapter	ME20 motor adapter (example) with EasyAdapt coupling
MQ		Square motor adapter with curved tooth or plug-in coupling
MR		Round motor adapter with curved tooth or plug-in coupling
MB		ServoStop motor adapter with brake
EZ	Motor	EZ synchronous servo motor
LM		LM Lean motor
IE3D		IE3D asynchronous motor

### 3.3 Nameplate

An example gear unit nameplate is explained in the figure below.

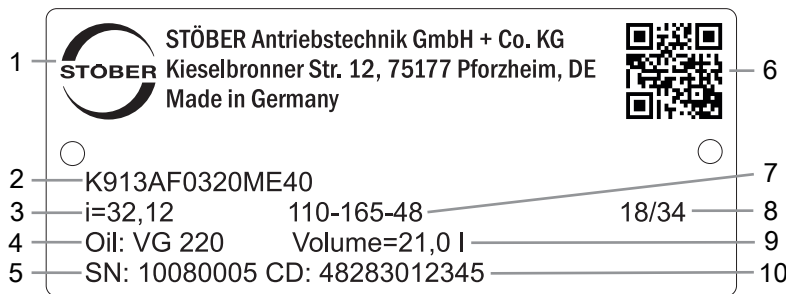

Code	Designation
1	Name of manufacturer
2	Type designation
3	Gear ratio of the gear unit
4	Lubricant specification
5	Serial number of the gear unit
6	QR code (link to product information)
7	Dimensions of the motor adapter (pilot/bolt circle/motor shaft diameter)
8	Date of manufacture (year/calendar week)
9	Lubricant fill volume
10	Customer-specific data

### 3.4 Mounting positions

The following table shows the standard mounting positions.

The numbers identify the gear unit sides. The mounting position is defined by the gear side facing downwards.

#### Installation positionf for gear unit sizes K1 – K4

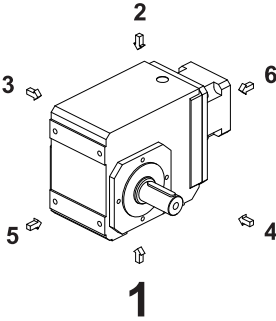
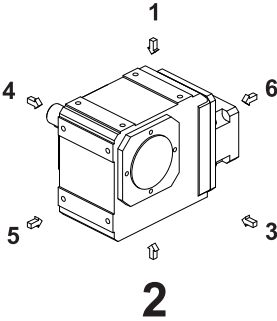
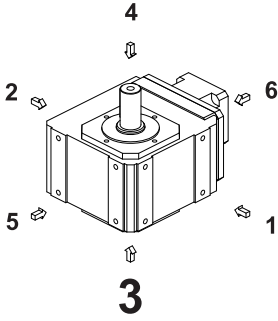
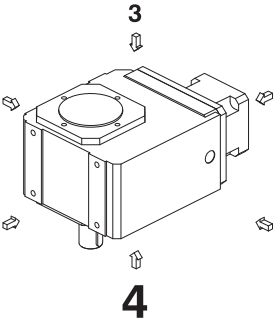
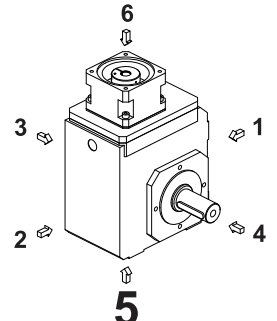
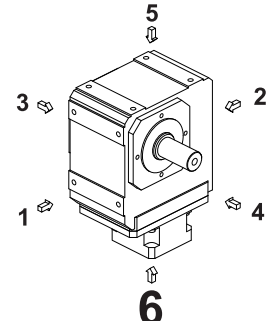
EL1	EL2	EL3
		
EL4	EL5	EL6
		

#### Mounting positions for gear unit sizes K5 – K10

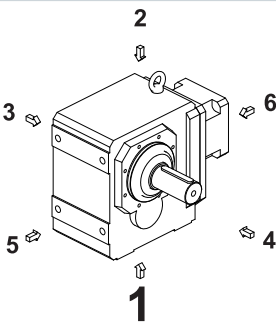
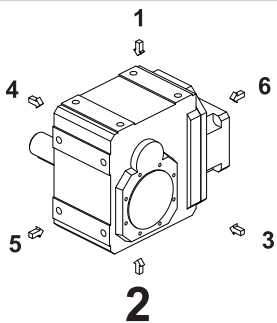
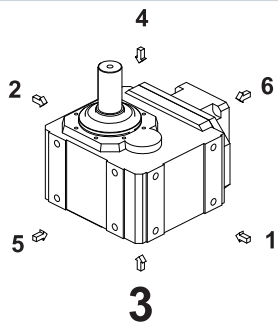
EL1	EL2	EL3
		

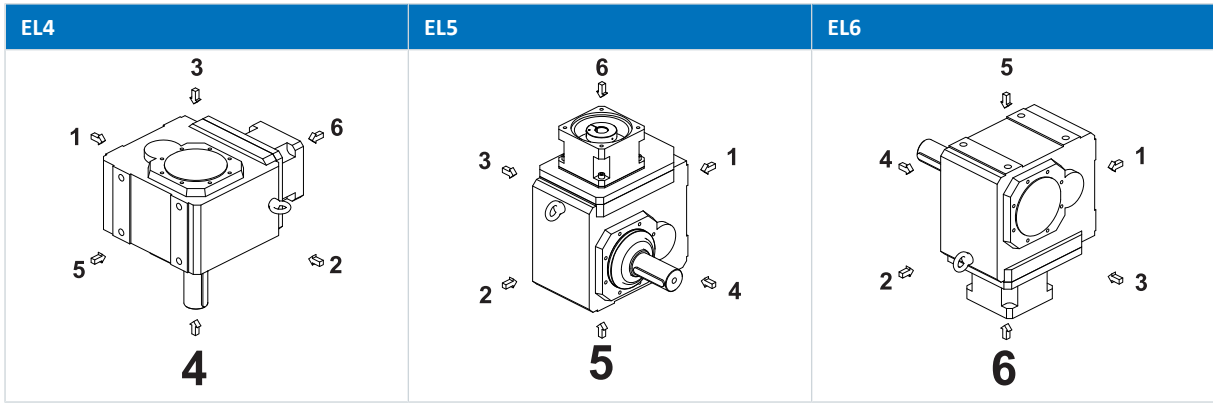

An adhesive label is applied to the gear unit that explains the designated mounting position. The arrow on the adhesive label indicates the side with which the gear unit must be mounted facing down.

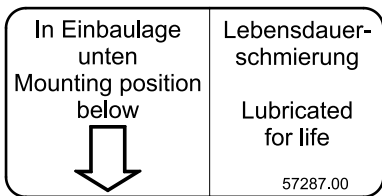
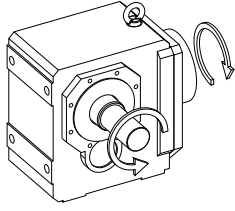
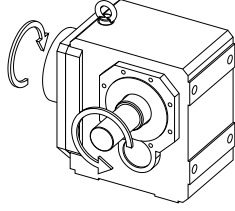

Fig. 1: Adhesive label for the mounting position

### 3.5 Direction of rotation

Solid shaft (V), solid shaft on both sides (V), hollow shaft with keyway (A)

Type	Output side 4	Output side 3
K102 – K402		
K203 – K403		
K513 – K1013		

Type	Output side 4	Output side 3
K514 – K1014		

The specified directions of rotation also apply to gear units with hollow shaft (A) if the entry side of the machine shaft corresponds to the side of the solid shaft that is shown.

The direction of rotation for the shaft design of a solid shaft on both sides corresponds to the direction of rotation for output side 4.

The pictures show mounting position EL1.

### Hollow shaft with shrink ring (S)

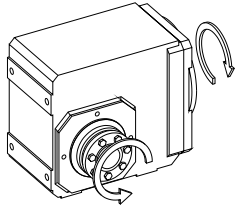
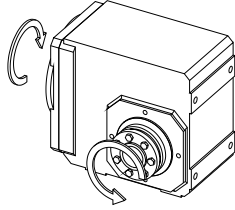
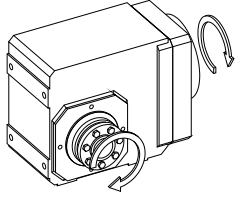
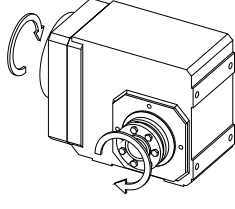
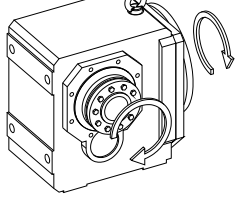
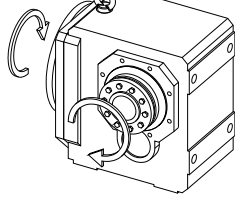
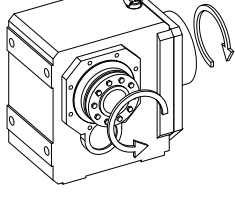
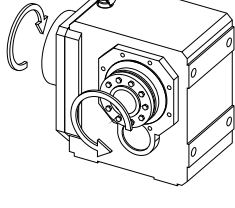
Type	Shrink ring side 4	Shrink ring side 3
K102 – K402		
K203 – K403		
K513 – K813		
K514 – K814		

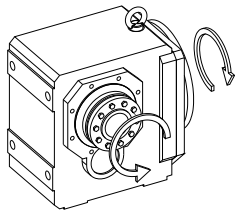
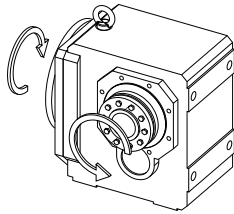
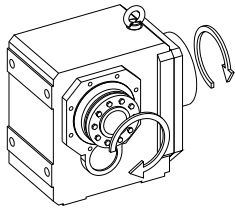
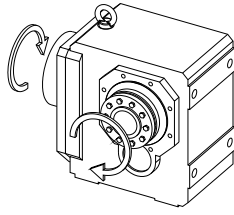
Type	Shrink ring side 4	Shrink ring side 3
K913 – K1013		
K914 – K1014		

The pictures show mounting position EL1.

## 3.6 Ambient conditions

Standard ambient conditions for transport, storage and operation of the gear unit are described in this chapter. Deviating ambient conditions for special designs are specified in the order confirmation. Ambient conditions for motors attached to a gear unit can be found in the technical documentation of the motor.

Feature	Description
Transport/storage surrounding temperature	-10 °C to +50 °C
Surrounding operating temperature	0 °C to +40 °C
Installation altitude	≤ 1000 m above sea level

### Notes

In order to prevent corrosion damage and damage to the shaft seal rings, protect the drive from the following influences:

- Environments with harmful oils, acids, gases, vapors, dust or radiation
- Extreme temperature fluctuations with high humidity
- Condensation or icing
- Strong UV radiation (e.g. direct sunlight)
- Presence of salt spray
- Sparks

In potentially explosive atmospheres, only gear units in an explosion-proof design in accordance with (ATEX) Directive 2014/34/EU may be used. Separate documentation applies to the explosion-proof design.

## 3.7 Other product features

Other features of gear units in the standard design can be found in the following table.

Feature	Description
Maximum permitted gear unit temperature (on the surface of the gear unit)	≤ 80 °C
Paint	Black RAL 9005
Lubricant	Synthetic; for specification and quantity, see nameplate
Ventilation	K1 – K4: No ventilation K5 – K10: Air release valves installed according to the mounting position
Weight	See order documents
Protection class: <sup>1</sup>	IP65

## 3.8 Additional documentation

You will find more information about the product at <http://www.stoeber.de/en/downloads/>. Enter the ID of the documentation in the Search... field.

Product combination	Catalog title	ID
Gear unit + ME/MEL/MF/MFL motor adapter	Servo gear units	443054_en
Gear unit + MB motor adapter with brake	ServoStop servo gear units with brake	443234_en
Gear unit + MQ/MR motor adapter	Power transmission gear units	441834
Gear unit + EZ synchronous servo motor	EZ synchronous servo geared motors	442437_en
Gear unit + LM Lean motor	Lean motors	443016_en
Gear unit + IE3D asynchronous motor	Asynchronous geared motors	443136_en
Gear unit	Lubricant filling quantities for gear units	441871

If you have questions about your drive that are not answered by this documentation, please contact STOBER Service ([Service](#) [[▶ 41](#)]).

<sup>1</sup> Observe the protection class of all the components.

## 4 Transport and storage

STOBER products are packaged carefully and delivered ready for installation. The type of packaging depends on the product size and the transport method.

Observe the following information during transport and storage:

- Inspect the delivery for any transport damage immediately upon receiving it and report any transport damage immediately. Do not put damaged products into operation.
- Check your delivery for completeness using the delivery note and report any missing parts to the supplier.
- Transport and store the product in the original packaging in order to protect it from damage. Remove the original packaging and transport safety devices shortly before assembly.

### Ambient conditions

The ambient conditions for transport and storage can be found in the chapter [Ambient conditions](#) [► 14].

## 4.1 Transport



### Suspended loads!

Loads that become loose and fall during the lifting process can cause serious injuries or even death!

- Observe the following instructions.
- Cordon off the danger zone and ensure that no one stands under the suspended loads.
- Wear safety shoes.

Lifting and transporting the drive may require lifting gear (e.g. a crane), depending on the weight. The weight of your drive is specified in the accompanying delivery documents.

Lift and transport the drive as follows:

- Use lifting gear with a sufficient lifting capacity for the weight of the drive.
- Run hoist slings directly around the drive housing and secure the hoist slings from slipping.

In order to prevent the drive from falling or getting damaged during transport, observe the following:

- Do not lift or fasten the drive on the output shaft or attached parts.
- Fasten the motor installed on the gear unit as well and make sure that there is no diagonal pull.

## 4.2 Storage

Store the drive in a dry, dust-free environment in the original packaging at a storage temperature between  $-10\text{ °C}$  and  $+50\text{ °C}$ .



## 4.2.1 Long-term storage

If you would like to store the drive for longer than 6 months, take the following steps to prevent corrosion damage:

1. Apply a suitable corrosion protection agent to unpainted surfaces, such as shaft ends or flange contact surfaces.
2. Completely fill the gear unit with lubricant. The lubricant specification can be found by entering the serial number of the gear unit at <https://id.stober.com> or by scanning the QR code on the nameplate of the gear unit.

Before commissioning the gear unit, reduce the lubricant fill volume to the fill volume that is specified on the nameplate of the gear unit.

# 5 Installation

This chapter contains information on how to correctly mount standard STOBBER drive designs and avoid injury to persons or damage to property. Differing information for customer-specific designs is included in the order documents.

Observe the technical documentation of the motor for the assembly and electrical connection of the motor.

Inspect the drive for transport or storage damage. If the drive is damaged, do not install it and contact the STOBBER Service department.

The following tools and equipment are required for mounting the drive:

- If necessary due to the overall weight, lifting gear with appropriate fastening elements and sufficient lifting capacity
- Open-end wrench set
- Socket wrench set
- Long hexagon insert set
- Torque wrench
- Grease
- Cleaning agent or solvent

Information about the specific tools or equipment can be found in the respective chapter.

## 5.1 Cleaning agent and solvent

Upon delivery, unpainted surfaces of the drive are protected by a corrosion protection agent. The corrosion protection agent must be removed from contact surfaces such as shaft ends and flange contact surfaces before assembly. STOBBER recommends removing the corrosion protection with a suitable cold cleaner (e.g. Carlofon Autocleaner) which, in contrast to volatile solvents, is almost odorless and does not weaken the sealing lips of the shaft seal rings. Otherwise, you can use commercially available solvents.

Be aware that all surfaces that come into contact with each other in a clamp connection must be degreased with a cold cleaner or solvent for error-free torque transmission. Additional information can be found in the following chapters.

**ATTENTION! Shaft seal rings can be damaged by solvents!** Prevent shaft seal rings from coming into contact with solvents when cleaning and degreasing unpainted surfaces.

## 5.2 Mounting the motor on a gear unit

This chapter contains information on how to mount a motor on a STOBBER gear unit with a motor adapter. The motor adapter type of your gear unit can be found on the nameplate of the gear unit. STOBBER recommends using a motor with a shaft without a feather key, since the keyway negatively affects smooth operation.

If you have a STOBBER geared motor, you can skip this chapter.

**ATTENTION! Damage to encoders, bearings and shafts due to improper assembly!** Never use force when mounting drive elements with fittings, e.g. hitting drive elements, shafts or the motor or gear housing with a hammer, and instead install them in accordance with the instructions in the documentation.

<b>Information</b>
--------------------

To make mounting the motor easier, stick to the following principal assembly order when possible:

- First mount the motor on the gear unit, then the geared motor on the machine
- Mount the motor on the gear unit with the motor shaft pointing down vertically in order to prevent unfavorable shifting and tilting of the motor shaft.

## 5.2.1 Permitted tilting torques at the gear unit input

If you mount a STOBBER gear unit on the machine in a horizontal mounting position, check that the permitted tilting torque is not exceeded on the gear unit input before mounting the corresponding motor. Information on the permitted tilting torque can be found in the corresponding catalog ([Additional documentation \[► 15\]](#)).

## 5.2.2 Tolerances for the add-on motor

This chapter describes tolerances for motors that are required for assembly on a STOBBER gear unit with motor adapter. Dimensional drawings of the motor adapter can be found in the corresponding catalog ([Additional documentation \[► 15\]](#)).

### Tolerances for shafts in accordance with DIN 748-1

Diameter [mm]	Tolerance
≤ 50	ISO k6
> 50	ISO m6

### Tolerances for centering diameter on the motor flange in accordance with EN 50347

Centering diameter [mm]	Flange size [mm]	Tolerance
≤ 230	65 – 300	ISO j6
> 230	350 – 500	ISO h6

### Tolerances for radial runout, axial runout and concentricity in accordance with IEC 60072-1 (normal class)

Symbol	Unit	Explanation
kx	μm	Concentricity of the flange centering in relation to the shaft
pl	μm	Axial runout of the flange mounting surface in relation to the shaft
r	μm	Radial runout of the shaft end

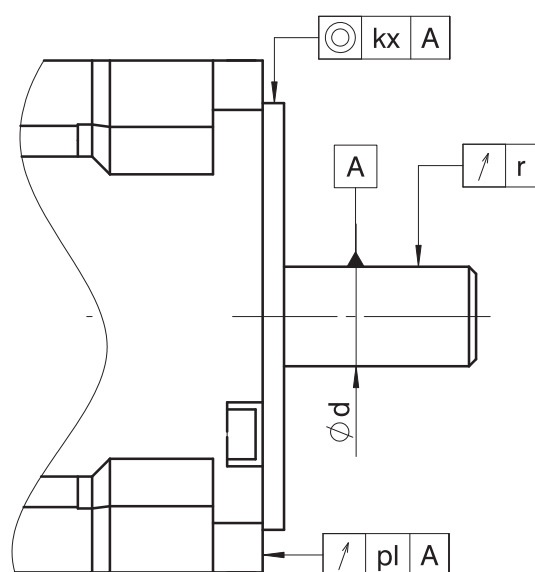

Ød [mm]	r [µm]
d ≤ 10	30
10 < d ≤ 18	35
18 < d ≤ 30	40
30 < d ≤ 50	50
50 < d ≤ 80	60

Centering diameter [mm]	Flange size	kx [µm]	pl [µm]
50 – 95	65 – 115	80	80
110 – 130	130 – 165	100	100
250 – 450	300 – 500	125	125

### 5.2.3 Mounting the motor on a gear unit with ME adapter

This chapter describes the assembly of a motor on a STOBBER gear unit with an ME motor adapter.

#### Prerequisites

- Dimensional tolerances of the motor correspond to the requirements in the chapter [Tolerances for the add-on motor](#) [[19](#)]
- The permitted tilting torque on the gear unit input is not exceeded (see [Permitted tilting torques at the gear unit input](#) [[19](#)])
- Four screws of strength class 8.8 are available for mounting the motor on a gear unit. The minimum screw depth for these screws is 1.6x the nominal diameter of the screw
- The necessary tools and aids are available (see [Installation](#) [[18](#)])
- The information in the chapter [Cleaning agent and solvent](#) [[18](#)] is observed

#### Procedure

In order to prevent unfavorable shifting or tilting of the motor shaft, STOBBER recommends mounting the motor on the gear unit with the motor shaft pointing down vertically.

1. Position the gear unit (5), if necessary with the aid of lifting gear, so that the motor can be mounted in a vertical position.
2. Remove the transport cover of the motor adapter.
3. If a feather key is installed on the motor shaft, remove it.
4. Remove all corrosion protection from the motor shaft and contact surfaces of the motor and motor adapter.
5. Carefully remove any lubricant from the inner hole of the clamping hub (15) and, if available, the inner and outer surface of the adapter bushing (6) for the motor shaft.
6. Unscrew the screw plug (13).
7. Turn the clamping hub so that the locking screw (11) can be turned over the bore for the screw plug (13), guide the hexagon insert (3) through the bore and insert it into the hexagon socket of the locking screw.
8. If an adapter bushing (6) is necessary, insert the adapter bushing into the inner hole of the clamping hub (15) as far as it will go and turn the adapter bushing so that the slot of the adapter bushing coincides with the slot of the clamping hub (10).

9. If necessary, use two suitable attachment points to secure the motor with the lifting gear so that the motor shaft is pointing down vertically.
10. Turn the motor in an axial position to the gear unit so that the nameplates are on the same side, if possible, and can also be read after installation in the machine.
11. If the motor shaft has a keyway, position the motor shaft so that the keyway is opposite the slot of the clamping hub (10).
12. An elastic bellow coupling is installed in the MF/MFL motor adapter that can assume a slightly tilted position, as long as the clamping hub is not connected with the motor shaft. Correct any existing tilt of the clamping hub before inserting the motor shaft.
13. Carefully place the motor on the motor adapter (4) and make sure that the motor shaft is inserted (7) in the clamping hub (15) so that it is centered and not at an angle.
14. If the motor shaft cannot be inserted into the clamping hub, do not use force and instead turn the locking screw (11) counterclockwise one quarter rotation with the hexagon insert (3) (in this process, the clamping hub widens because the grooved pin (12) locks against the cylinder head of the locking screw). The size of the hexagon insert can be found on the adhesive label (14) as well as in the following tables.
15. If necessary, repeat the previous step.
16. The contact surfaces of the motor flange and motor adapter flange must fit together without a gap. If this is not the case, do not use force and instead check the dimensions of the motor.
17. Mount the motor on the motor adapter with screws (9). Tighten the screws evenly, with increasing torque and alternating diagonally. The tightening torque can be found in the chapter [Tightening torques \[▶ 35\]](#).
18. Insert the torque wrench (2) in the hexagon insert (3) and tighten the locking screw (11). The corresponding tightening torque can be found in the following table and on the adhesive label on the motor adapter.
19. If the motor flange does not fully cover the bores or openings of the motor adapter, seal off the openings with a suitable sealant. This maintains the protection class of the gear unit so that dust and water cannot get into the interior of the motor adapter.
20. Plug the access hole with the screw plug (13) by screwing it in until it is flush with the surface of the motor adapter.

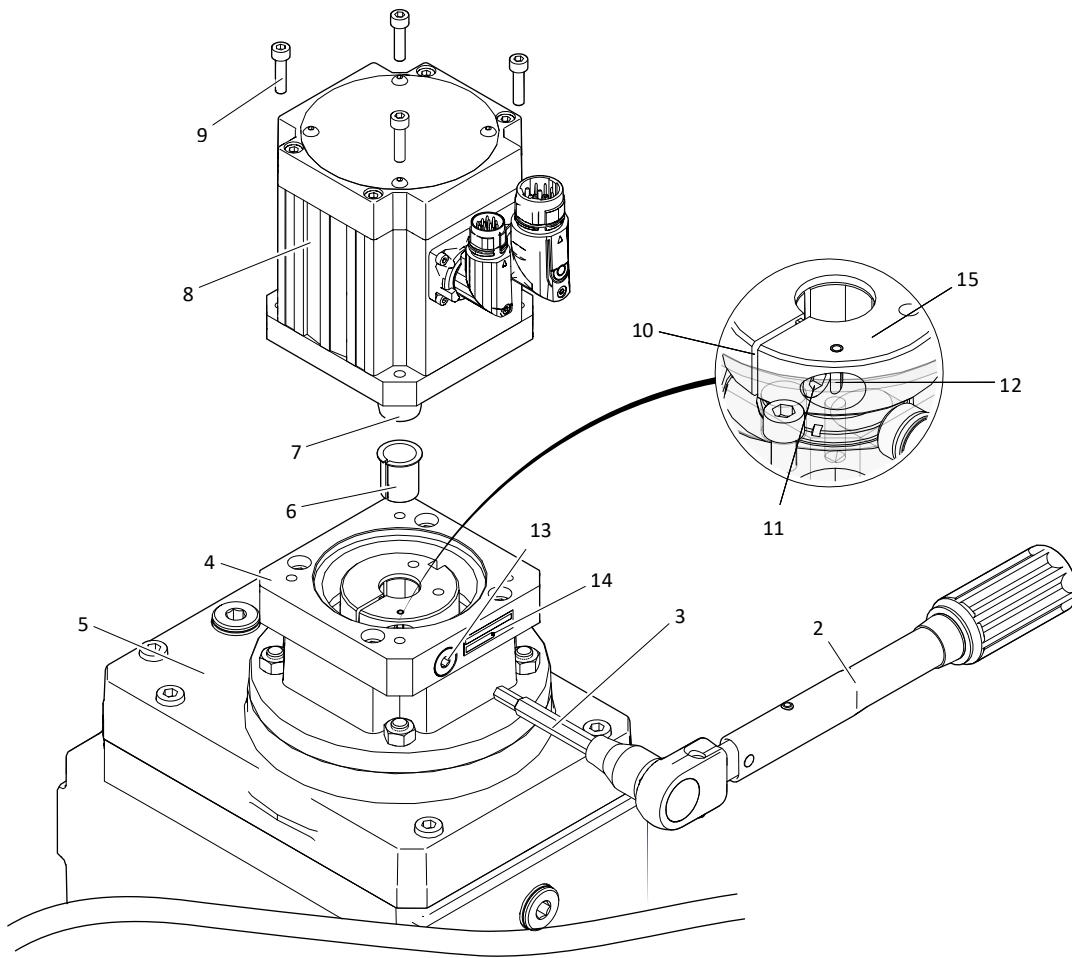

Fig. 2: Mounting a motor on a K gear unit with ME motor adapter (example)

- |    |                              |    |                |
|----|------------------------------|----|----------------|
| 2  | Torque wrench                | 3  | Hexagon insert |
| 4  | Motor adapter                | 5  | Gear unit      |
| 6  | Adapter bushing (if present) | 7  | Motor shaft    |
| 8  | Motor                        | 9  | Screw          |
| 10 | Slot of the clamping hub     | 11 | Locking screw  |
| 12 | Grooved pin                  | 13 | Screw plug     |
| 14 | Adhesive label               | 15 | Clamping hub   |

**Tightening torques for the locking screw (11)**

The tightening torques for the locking screw are in line with the size of the ME adapter on the gear unit input and the diameter of the motor shaft.

Type	d2 [mm]	KS	s [mm]	M <sub>A</sub> [Nm]
_ME10	d2≤14	M5	4	5.9
_ME10	14<d2≤19	M6	5	10
_ME20	d2≤19	M6	5	10
_ME20	19<d2≤24	M8	6	25
_ME30	d2≤24	M8	6	25

Type	d2	KS	s	M <sub>A</sub>
	[mm]		[mm]	[Nm]
_ME20	24<d2≤32	M10	8	49
_ME30	24<d2≤38	M10	8	49
_ME40	d2≤38	M10	8	49
_ME40	38<d2≤48	M12	10	85
_ME50	55<d2≤60	M16	14	210

Abbreviations used:

- KS = Nominal diameter of the locking screw (11)
- M<sub>A</sub> = Tightening torque for the locking screw (11)
- s = Size of the hexagon insert (3)
- d2 = Motor shaft diameter

## 5.2.4 Mounting the motor on a gear unit with MQ/MR adapter with curved tooth coupling

This chapter describes the attachment of a motor with a solid shaft with feather key to a STOBBER gear unit with an MQ (for a square motor flange) or MR (for a round motor flange) motor adapter with a curved tooth coupling. Since the assembly steps for the MQ or MR motor adapter are identical, only one motor adapter type is shown in the figures.

### Prerequisites

- Dimensional tolerances of the motor correspond to the requirements in the chapter [Tolerances for the add-on motor](#) [[▶ 19](#)]
- The feather key corresponds to DIN 6885-1;
- The shaft shoulder and flange contact surface of the motor are on one plane (see the following sectional drawing);
- The shaft length of the motor is not longer than defined in IEC 60072-1 (see the following table and sectional drawing);
- The permitted tilting torque on the gear unit input is not exceeded (see [Permitted tilting torques at the gear unit input](#) [[▶ 19](#)])
- The necessary tools and aids are available (see [Installation](#) [[▶ 18](#)])
- The information in the chapter [Cleaning agent and solvent](#) [[▶ 18](#)] is observed

### Procedure

1. Remove all corrosion protection from the motor shaft and contact surfaces of the motor and motor adapter.
2. Carefully degrease the inner hole of the motor-side coupling hub (3).
3. Pull the motor-side coupling hub (3) onto the motor shaft up to the shaft shoulder. You can find more details on this in the chapter [Mounting drive elements on a solid shaft](#) [[▶ 27](#)].
4. If you heated the coupling hub to pull it on, allow it to cool.
5. Secure the coupling hub (3) with the set screw (9) and tighten it with the tightening torque according to the following table.
6. Position the gear unit (5), if necessary with the aid of lifting gear, so that the motor can be mounted in a vertical position.
7. Connect the coupling sleeve (8) to the gear unit-side coupling hub (7).

8. If necessary, use two suitable attachment points to secure the motor with the lifting gear so that the motor shaft is pointing down vertically.
9. Turn the motor in an axial position to the gear unit so that the nameplates are on the same side, if possible, and can also be read after installation in the machine.
10. Carefully place the motor on the motor adapter such that the motor-side coupling hub (3) is inserted into the coupling sleeve (8) centered and the curved teeth of the coupling hub easily mesh with the internal teeth of the coupling sleeve.
11. The contact surfaces of the motor flange and motor adapter flange must fit together without a gap. If this is not the case, do not use force and instead check the dimensions of the motor.
12. Mount the motor on the motor adapter using the corresponding fastening screws (1) in **strength class 8.8**. If the fastening holes of the motor adapter are unthreaded, use nuts (5) in strength class 8.
13. Tighten the fastening screws with the corresponding tightening torque (see chapter Tightening torques).

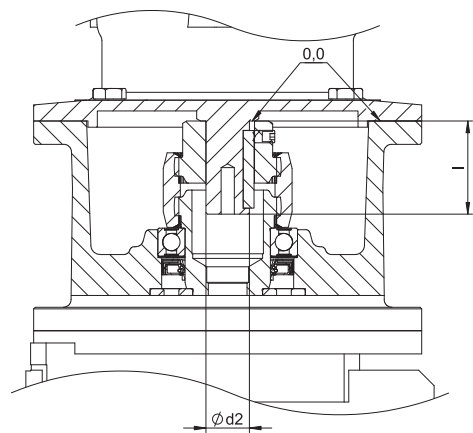
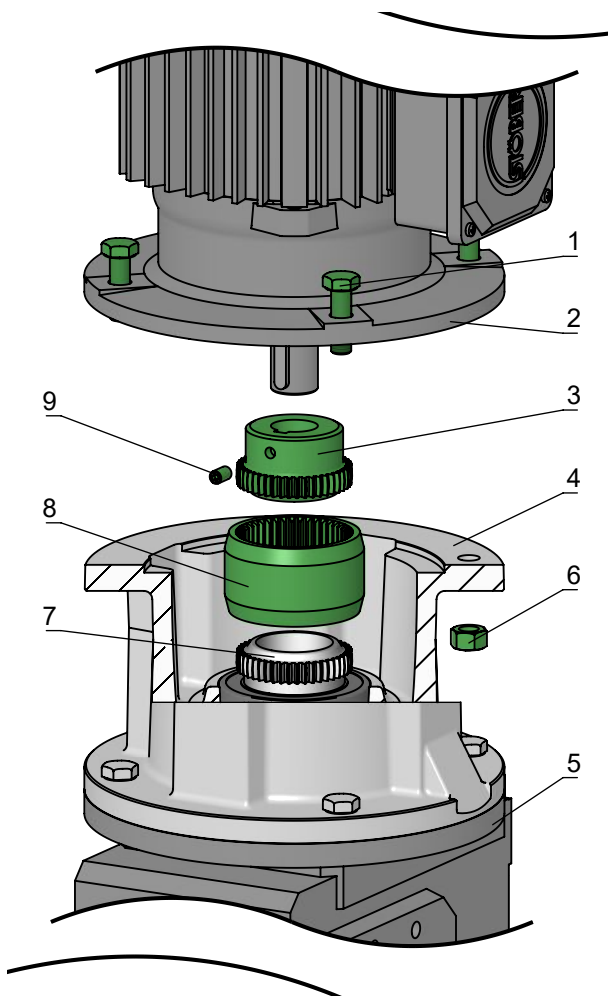

- |   |                               |   |                 |
|---|-------------------------------|---|-----------------|
| 1 | Screw                         | 2 | Motor           |
| 3 | Coupling hub (motor side)     | 4 | Motor adapter   |
| 5 | Nut                           | 6 | Gear unit       |
| 7 | Coupling hub (gear unit side) | 8 | Coupling sleeve |
| 9 | Set screw                     |   |                 |



### Nominal sizes of the shaft end according to IEC 60072-1

Diameter d2 [mm]	11	14	19	24	28	38	42	48	55	60
Length l [mm]	23	30	40	50	60	80	110	110	110	140

### Tightening torques for set screw (9)

Size of hexagon insert [mm]	2.5	4
Tightening torque [Nm]	2	10

## 5.2.5 Mounting the motor on a gear unit with MQ/MR adapter with plug-in coupling

This chapter describes the attachment of a motor with a solid shaft without feather key to a STOBBER gear unit with an MQ (for a square motor flange) or MR (for a round motor flange) motor adapter with a plug-in coupling. Since the assembly steps for the MQ or MR motor adapter are identical, only one motor adapter type is shown in the figures.

### Prerequisites

- The motor has a smooth shaft;
- Dimensional tolerances of the motor correspond to the requirements in the chapter [Tolerances for the add-on motor](#) [[▶ 19](#)]
- The offset between the shaft shoulder and flange surface of the motor is  $\leq 0.4$  mm; otherwise, the gear rim is tensioned axially and the plug-in coupling can be damaged (see the following sectional drawing);
- No motor parts (e.g. screws) protrude over the flange surface in the flange area;
- The permitted tilting torque on the gear unit input is not exceeded (see [Permitted tilting torques at the gear unit input](#) [[▶ 19](#)])
- The necessary tools and aids are available (see [Installation](#) [[▶ 18](#)])
- The information in the chapter [Cleaning agent and solvent](#) [[▶ 18](#)] is observed

### Procedure

1. Remove all corrosion protection from the motor shaft and contact surfaces of the motor and motor adapter.
2. Carefully degrease the inner hole of the clamping hub (10).
3. Connect the clamping hub (10) to the motor shaft up to the shaft shoulder. If the clamping hub is difficult to fit in place, do not use force and instead heat the clamping hub to about 70 °C before fitting.
4. If you heated the clamping hub to connect it, allow it to cool.
5. Tighten the clamping screws (3) gradually, alternating diagonally, with the tightening torque according to the following table.
6. Position the gear unit, if necessary with the aid of lifting gear, such that the motor can be mounted in a vertical position. As needed, use suitable equipment, such as appropriate wood blocks or pipe pieces, to support the gear housing. Make sure that the gear unit is not tilted and that the motor adapter is precisely aligned upwards.
7. Grease the gear rim (8) and connect it to the gear unit-side coupling hub (7).
8. If necessary, use two suitable attachment points to secure the motor with the lifting gear so that the motor shaft is pointing down vertically.

9. Turn the motor in an axial position to the gear unit so that the nameplates are on the same side, if possible, and can also be read after installation in the machine.
10. Carefully place the motor on the motor adapter and make sure that the claws of the motor-side clamping (9) are positioned between the claws of the gear unit-side coupling hub (7) and the teeth of the gear rim (8).
11. Make sure that the gear rim is not tensioned axially when mounting the motor. Otherwise, the plug-in coupling can be damaged.
12. The contact surfaces of the motor flange and motor adapter flange must fit together without a gap. If this is not the case, do not use force and instead check the dimensions of the motor.
13. Mount the motor on the motor adapter using the corresponding fastening screws (1) in **strength class 8.8**. If the fastening holes of the motor adapter are unthreaded, use nuts (5) in strength class 8.
14. Tighten the fastening screws with the corresponding tightening torque (see chapter Tightening torques).

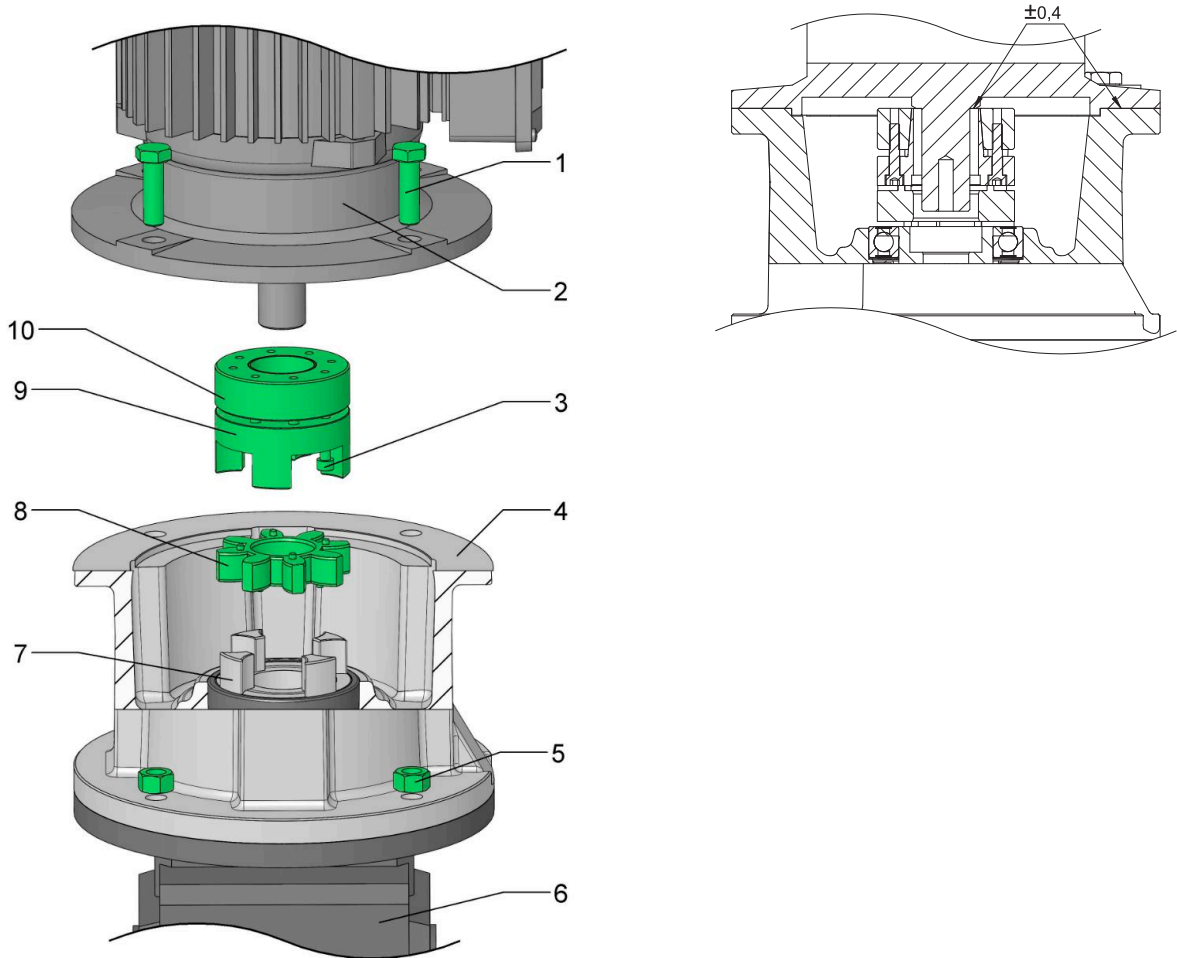

- |   |                               |    |               |
|---|-------------------------------|----|---------------|
| 1 | Fastening screw               | 2  | Motor         |
| 3 | Clamping screw                | 4  | Motor adapter |
| 5 | Nut                           | 6  | Gear unit     |
| 7 | Coupling hub (gear unit side) | 8  | Gear rim      |
| 9 | Clampring                     | 10 | Clampring hub |

### Tightening torques for clamping screws (3)

Size of clamping screw [mm]	M4	M5	M6	M8
Tightening torque [Nm]	3	5.9	10	36

## 5.2.6 Mounting the motor on a gear unit with MB adapter

The assembly of a motor on a gear unit with an MB motor adapter with brake is described in a separate document (see [Supporting documents](#) [[▶ 5](#)]).

## 5.3 Mounting the output shaft

This chapter contains information on how to correctly connect the different designs of the gear unit output shaft with the machine so that the torque can be transmitted properly.

### 5.3.1 Mounting drive elements on a solid shaft

This chapter describes the assembly of drive elements, such as hubs, belt drives, couplings, pinions or sprockets, on the output of a gear unit with a solid shaft and feather key.

When mounting drive elements on a solid shaft without a feather key, observe the technical documentation of the drive element in question.

**ATTENTION! Damage to encoders, bearings and shafts due to improper assembly!** Never use force when mounting drive elements with fittings, e.g. hitting drive elements, shafts or the motor or gear housing with a hammer, and instead install them in accordance with the instructions in the documentation.

#### Prerequisites

- The drive element does not cause any impermissible shaft loads (e.g. tensioning the belt on a belt drive). Information on permissible shaft loads can be found in the corresponding catalog (see [Additional documentation](#) [[▶ 15](#)]);
- The drive element is balanced;
- The tolerance of the inner hole of the drive element is ISO H7;
- The keyway of the drive element corresponds to DIN 6885-1 (if not otherwise specified);
- The information in the chapter [Cleaning agent and solvent](#) [[▶ 18](#)] is observed
- A mounting device suitable for the drive element is available (not included in the scope of delivery of the gear unit).

#### Procedure

1. Remove the corrosion protection from the solid shaft.
2. Degrease the inner hole of the drive element.
3. Mount the drive element on the solid shaft with the aid of a mounting device positioned on the centering hole of the solid shaft. Details can be found in the following figure and table.
4. If the drive element is difficult to hoist, do not use force and instead heat it to about 80 °C beforehand.
5. If the length of the solid shaft is greater than the length of the drive element, use an appropriate spacer bushing that you position between the plate (1) and drive element (5).

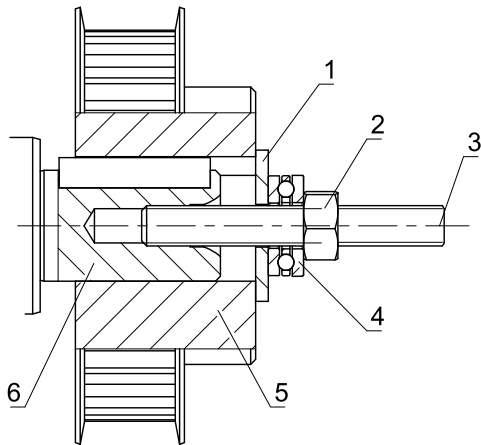

Fig. 3: Mounting device for a belt drive (example)

- |   |                      |   |               |
|---|----------------------|---|---------------|
| 1 | Washer               | 2 | Nut           |
| 3 | Set screw            | 4 | Axial bearing |
| 5 | Belt drive (example) | 6 | Solid shaft   |

### 5.3.2 Mounting a hollow shaft with keyway

This chapter describes how to mount gear units with a hollow shaft and keyway on a machine shaft. A keeper plate with internal thread is integrated in the hollow shaft. It is used to remove the hollow shaft from the machine shaft again.

The inner hole of the hollow shaft has a spiral-shaped groove. This helps distribute the grease in the inner hole of the hollow shaft and makes mounting and removing the hollow shaft easier.

#### Tools

- Cylinder screw for pulling on the hollow shaft (thread size according to the following table)
- Flat washer
- Machine grease

#### Prerequisites

- The information in the chapter [Cleaning agent and solvent \[▶ 18\]](#) is observed
- The dimensions of the machine shaft and feather key correspond to the following specifications.

Ødh [mm]	16 <sup>H7</sup>	20 <sup>H7</sup>	25 <sup>H7</sup>	30 <sup>H7</sup>	35 <sup>H7</sup>	40 <sup>H7</sup>	50 <sup>H7</sup>	60 <sup>H7</sup>	70 <sup>H7</sup>	90 <sup>H7</sup>	100 <sup>H7</sup>
dm <sub>tol</sub>	ISO k6	ISO k6	ISO k6	ISO k6	ISO k6	ISO k6	ISO k6	ISO m6	ISO m6	ISO m6	ISO m6
sm	M5	M6	M10	M10	M12	M16	M16	M20	M20	M24	M24
lm <sub>min</sub> [mm]	35.2	44	55	66	77	88	110	132	154	176	220
lpm <sub>min</sub> [mm]	32	40	50	60	70	80	100	120	140	180	200
pm <sub>norm</sub>	DIN 6885-1	DIN 6885-1	DIN 6885-1	DIN 6885-1 <sup>2</sup>	DIN 6885-1	DIN 6885-1	DIN 6885-1	DIN 6885-1	DIN 6885-1	DIN 6885-1	DIN 6885-1

Tab. 3: Specifications for the machine shaft and feather key

<sup>2</sup>(for K1 DIN 6885-3)

Dimension name	Explanation
$\varnothing dh$	Inner diameter of the hollow shaft
sm	Diameter of the threaded hole in the machine shaft
$l_{m_{min}}$	Minimum length of the machine shaft
$l_{pm_{min}}$	Minimum length of the feather key on the machine shaft
$dm_{tol}$	Diameter tolerance of the machine shaft in accordance with DIN 748-1
$pm_{norm}$	Standard to which the feather key must correspond

### Procedure

1. Remove any covers from the hollow shaft.
2. Remove the corrosion protection from the machine shaft, inner hole of the hollow shaft and other contact surfaces.
3. Apply grease to the machine shaft (1) and distribute it evenly.
4. Pull the gear unit onto the machine shaft with the help of the cylinder screw (4) and washer (5) up to the stop, which is determined by the shoulder of the machine shaft, the keeper plate or the gear unit flange.
5. Remove the cylinder screw (4) and washer (5).
6. If the torque of the gear unit is absorbed by a torque arm bracket, secure the shaft connection axially using an appropriate screw.

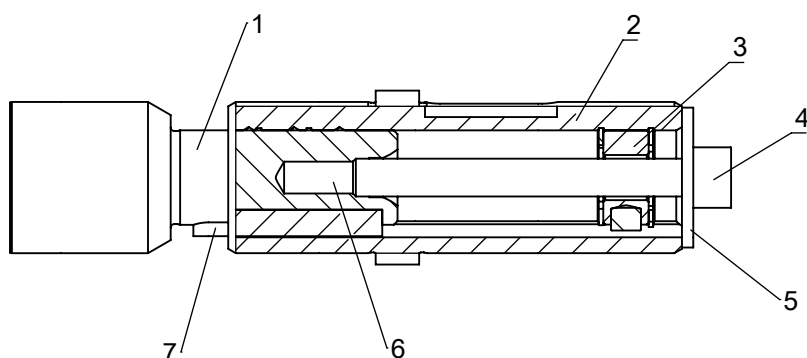

1	Machine shaft	2	Hollow shaft
3	Keeper plate	4	Cylinder screw
5	Washer	6	Threaded hole
7	Feather key		

### 5.3.3 Mounting a hollow shaft with shrink ring

This chapter describes how to mount gear units with a hollow shaft and shrink ring on a machine shaft.

#### Prerequisites

- Material of the machine shaft has a permissible surface pressure  $p \geq 325 \text{ N/mm}^2$ ;
- The information in the chapter [Cleaning agent and solvent](#) [▶ 18] is observed
- The fit tolerance of the machine shaft corresponds to the following table.

**Fit tolerance of the machine shaft**

∅ds [mm]	Tolerance
ds ≤ 50	ISO h9
ds > 50	ISO h6

**Procedure**

**ATTENTION! Property damage!** Only tighten the clamping screws of the shrink ring after you have inserted the gear unit onto the machine shaft. Otherwise, the hollow shaft can be plastically deformed.

1. Remove the closing und cover caps from the hollow shaft and shrink ring.
2. Remove the corrosion protection from the machine shaft (2), the bore of the hollow shaft (3) and shrink ring (4) and other contact surfaces.
3. Carefully degrease the machine shaft in the press area of the shrink ring 7 and the hollow shaft, inside and out, in the press area 8 such that the torque can be transferred completely.
4. Apply grease to the machine shaft in the contact area 6 with the bush.
5. Insert the gear unit with the hollow shaft onto the machine shaft.
6. If the hollow shaft is slitted in the press area, position the shrink ring at a distance fs from the end of the hollow shaft (see the following figure and table). Otherwise, position the shrink ring at the stop on the collar of the hollow shaft.
7. Tighten the clamping screws of the shrink ring evenly in several cycles by one quarter rotation each in turn (not alternating diagonally) up to the specified tightening torque (see the following table). When tightening the clamping screws, make sure that the clamping plates of the shrink ring remain plane-parallel to each other and do not touch.

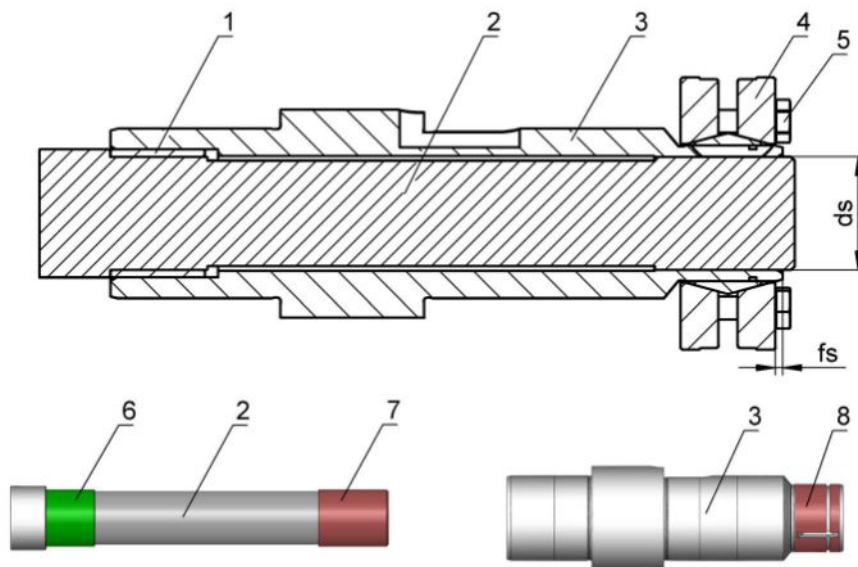

- |   |                         |   |   |
|---|-------------------------|---|---|
| 1 | Socket                  | 2 | Machine shaft                           |
| 3 | Hollow shaft            | 4 | Shrink ring                             |
| 5 | Clamping screw          | 6 | Surface, greased                        |
| 7 | Surface, free of grease | 8 | Inner and outer surface, free of grease |

### Information on mounting the shrink ring

Gear unit type	ds [mm]	fs	M <sub>A</sub> [Nm]	Width across flats [mm]
K1	25	3	5	8
K2	30	3	12	10
K3	35	3	12	10
K4	40	3	12	10
K5	50	4	12	10
K6	50	4	12	10
K7	60	–	30	13
K8	70	–	35	13
K9	90	–	59	16
K10	100	–	69	16

Abbreviations used:

- ds = Inner diameter of the shrink ring
- fs = Distance between end of hollow shaft and shrink ring
- M<sub>A</sub> = Tightening torque of the clamping screws

The table contains tightening torques for standard hollow shafts. For customer-specific designs, the applicable tightening torques are those applied to the shrink ring used.

## 5.4 Mounting the gear unit on the machine

Depending on the design, the K gear unit is mounted on the machine using the pitch circle diameter, output flange or foot plates. In applications where the gear unit is attached to the machine shaft using a hollow shaft, the reaction torque can be absorbed by a torque arm bracket. The installation of the torque arm bracket is described in a separate chapter.

### Prerequisites

- The connecting structure for the drive in the machine is dimensioned according to the weight and torque and takes forces that act on the drive into account;
- The connecting structure is flat, vibration-reducing and torsion-resistant;  
The perpendicularity deviation of the flange contact surface of the connecting structure to the gear unit shaft axis does not exceed 0.03 mm per 100 mm;
- The gear housing is grounded via the connecting structure or attached motor;
- The tolerance of the centering diameter of the connecting structure is ISO H7;
- Sufficient ventilation for the mounted drive is ensured.

### Procedure

1. Remove the corrosion protection from the contact surfaces of the pitch circle diameter/output flange/foot plates and from the connecting structure.
2. For a gear unit with a solid shaft, mount the defined drive elements on the solid shaft (see [Mounting drive elements on a solid shaft](#) [▶ 27]).
3. Position the gear unit in the mounting position in the machine, using lifting gear if necessary.

4. Position the gear unit in the specified mounting position.
5. For a gear unit with a hollow shaft and keyway, mount the hollow shaft on the machine shaft (see [Mounting a hollow shaft with keyway](#) [▶ 28]).
6. For a gear unit with a hollow shaft and shrink ring, mount the hollow shaft to the machine shaft (see [Mounting a hollow shaft with shrink ring](#) [▶ 29]), but do not yet tighten the clamping screws of the shrink ring.
7. Center the gear unit in the connecting structure using the pilot of the gear housing or output flange.
8. Mount the gear unit on the connecting structure using screws. Details on the screws can be found in the following table.
9. If the gear unit is also mounted using the foot plates, make sure that the foot plates are not tensioned against the housing mounting surface or output flange.
10. Tighten the screws evenly in multiple passes with increasing torque and alternating diagonally. The tightening torques can be found in the chapter [Tightening torques](#) [▶ 35].
11. Tighten the clamping screws for the gear unit with hollow shaft and shrink ring (see [Mounting a hollow shaft with shrink ring](#) [▶ 29]).

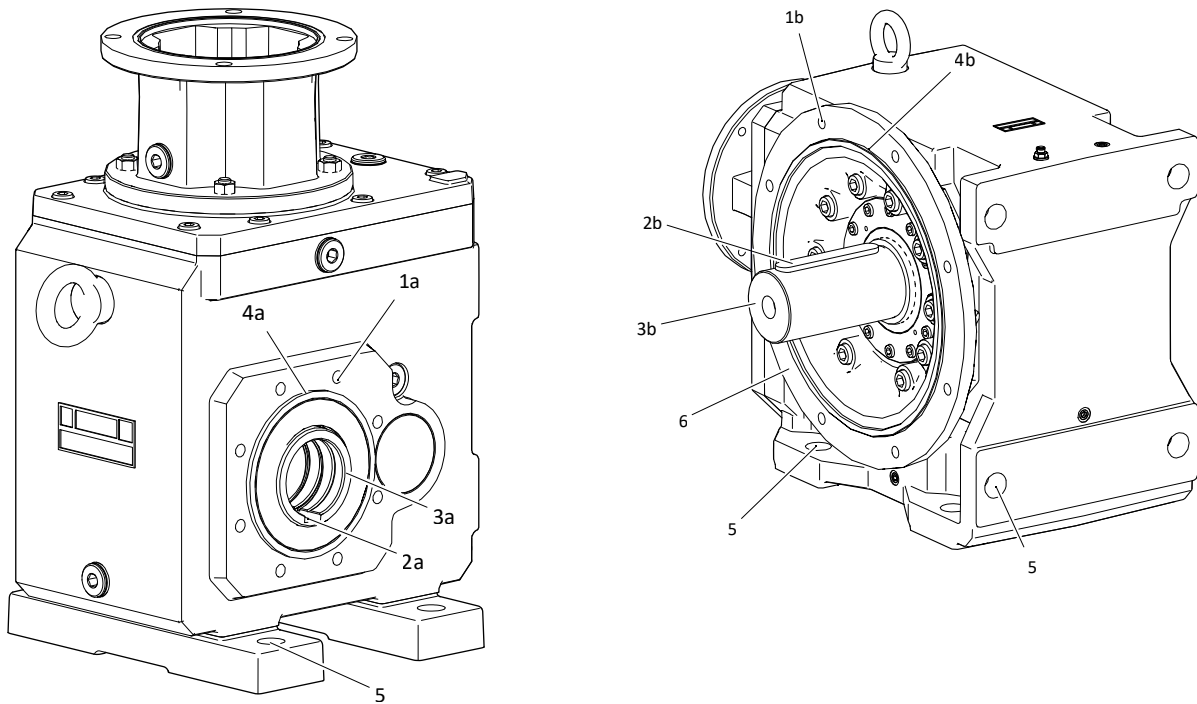

Tab. 4: Mounting the gear unit to the machine, using K513\_AF (left) and a K 1013\_VNF gear unit (right) as an example

1a	Threaded hole in the housing	1b	Output flange bore
2a	Keyway of the hollow shaft	2b	Feather key
3a	Hollow shaft	3b	Solid shaft
4a	Housing pilot	4b	Output flange pilot
5	Foot plate bore	6	Output flange



Gear unit type	Number of screws	Screw size	Min. screw-in depth [mm]	Strength class
K1_G	4	M8	12	10.9
K2_G	4	M8	12	10.9
K3_G	4	M8	12	10.9
K4_G	4	M10	15	10.9
K5_G	8	M10	15	10.9
K6_G	8	M10	15	10.9
K7_G	8	M12	18	10.9
K8_G	12	M12	18	10.9
K9_G	8	M16	24	10.9
K10_G	10	M20	30	10.9
K1_D	4	M8	–	8.8
K2_D	4	M8	–	8.8
K3_D	4	M8	–	8.8
K4_D	4	M8	–	8.8
K5_D	4	M12	–	8.8
K6_D	4	M12	–	8.8
K7_D	4	M16	–	8.8
K8_D	4	M16	–	8.8
K9_D	8	M16	–	8.8
K10_D	8	M16	–	8.8
K1_N	4	M8	–	8.8
K2_N	4	M10	–	8.8
K3_N	4	M10	–	8.8
K4_N	4	M12	–	8.8
K5_N	4	M16	–	8.8
K6_N	4	M16	–	8.8
K7_N	4	M20	–	8.8
K8_N	4	M24	–	8.8
K9_N	4	M30	–	8.8
K10_N	4	M36	–	8.8

Tab. 5: Information on screws for mounting the gear housing on the machine

### 5.4.1 Mounting the torque arm bracket

For gear units with a hollow shaft attached to the machine shaft, the torque arm bracket absorbs the reaction torque. The torque arm bracket can be mounted on different gear unit sides and different positions.

#### Prerequisites

- You mounted the hollow shaft on the machine shaft.
- You mounted the gear unit to the machine such that the weight of the gear unit is absorbed by the pitch circle diameter, output flange or foot plate.

**Procedure**

Observe the following when mounting the torque arm bracket:

- Mount the torque arm bracket so that the bush (13) of the torque arm bracket is positioned on the side where the machine shaft (7) is connected. This prevents additional bending stress.
- Support the bush of the torque arm bracket from both sides; otherwise, too much load is put on it during operation.
- Mount the torque arm bracket without tension to ensure that the gear unit is not under additional load.
- Prevent the bushes from making contact with solvents, oils and greases, as otherwise they may be damaged.

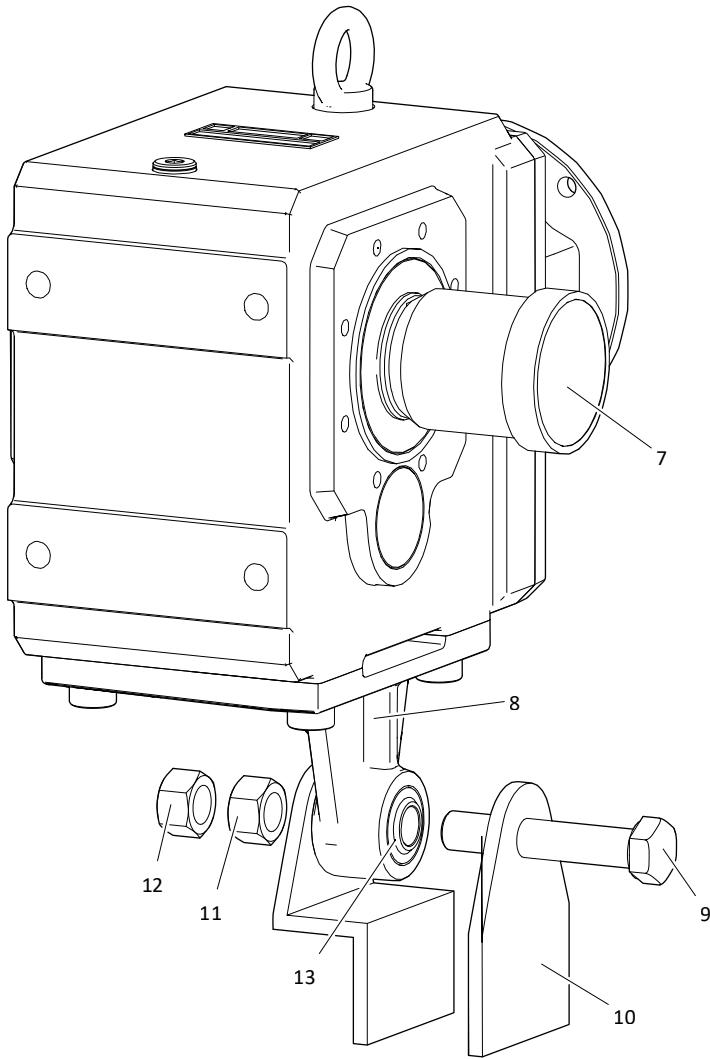

Fig. 4: Mounting a K513\_AGD gear unit (example)

7	Machine shaft <sup>1</sup>	8	Torque arm bracket
9	Hex head screw <sup>1</sup>	10	Bearing <sup>1</sup>
11	Hex nut <sup>1</sup>	12	Locking nut <sup>1</sup>
13	Bush		

<sup>1</sup> These mounting elements are not included in the scope of delivery of the gear unit.

## 5.5 Tightening torques

Note that the following tightening torques apply to screws that are used for mounting the motor on the gear unit or the gear unit on the machine. For clamp couplings, clamping screws of shrink rings and other connection elements, other tightening torques apply that are specified in the specific context.

Thread	Tightening torque $M_A$ [Nm]		
	Strength class 8.8	Strength class 10.9	Strength class 12.9
M4	3.3	4.8	5.6
M5	6.5	9.5	11.2
M6	11.3	16.5	19.3
M8	27.3	40.1	46.9
M10	54	79	93
M12	93	137	160
M14	148	218	255
M16	230	338	395
M18	329	469	549
M20	464	661	773
M22	634	904	1057
M24	798	1136	1329
M27	1176	1674	1959
M30	1597	2274	2662
M36	2778	3957	4631

Tab. 6: Tightening torques for screws with metric standard thread in accordance with DIN 13-1 (coefficient of friction  $\mu_{ges} = 0.14$ ).

## 6 Commissioning

### 6.1 Before commissioning

**WARNING! Moving machine parts can cause serious injuries or even death!** Before performing work, switch off the machine with the main switch and secure the switch from being turned on again.

Before commissioning the drive, make sure that the following prerequisites are met:

- The drive is undamaged
- The mechanical assembly and electrical connection of the drive has been completed
- The drive is not blocked
- Any present feather keys are secured against being thrown for a test run with drive elements
- All protective devices have been properly mounted
- All monitoring equipment is activated
- The drive controller is adjusted so that an overload of the gear unit in relation to the permitted torque is prevented by the motor
- The ambient conditions are observed (see [Ambient conditions \[▶ 14\]](#))

### 6.2 During commissioning

**WARNING! Moving machine parts can cause serious injuries or even death!** Make sure that no one is standing in the danger area or able to enter it unchecked.

**WARNING! Falling gravity-loaded axes or vertical axes can cause serious injuries or even death!** Move gravity-loaded axes or vertical axes to their lowest position and lock or brace them mechanically before entering the danger area.

**WARNING! If the motor is in operation while plug connectors are being disconnected, electric arcs can cause severe injury or even death.** Do not connect or disconnect the plug connectors until after the motor is de-energized.

**WARNING! Flying metal parts can cause serious injuries!** Assemble the provided power transmission elements properly or remove the feather key before a test run.

**CAUTION! The surface of the drive can reach temperatures over 65 °C during operation!** Allow the drive to cool sufficiently before working on it. Wear gloves.

During commissioning, check the following:

- After the any existing brakes released before starting the drive?
- Is the direction of rotation of the drive correct?
- When the drive is running, do any overloading, unwanted speed fluctuations, unusual noises or vibrations occur?

In case of faults, observe the chapter [Troubleshooting faults \[▶ 40\]](#).

#### Measurement of the surface temperature

For safe operation, it must be ensured that the surface temperature of the gear unit does not exceed the maximum permitted value. For this purpose, perform measurements with a commercially available temperature measuring device. Determine the surface temperature at the transition between gear unit and motor adapter or between gear unit and motor.

The maximum surface temperature occurs in approx. 3 hours, depending on the utilization of the drive, and must not exceed the maximum value of 90 °C in the event of a maximum surrounding temperature. Immediately shutdown the drive if the maximum value is exceeded and contact STOBBER Service.

## 7 Servicing

### 7.1 Cleaning

If the surface of the drive is dirty, heat dissipation through the ambient air is no longer sufficient. As a result, impermissibly high operating temperatures that reduce the lubricating effect of the lubricant and accelerate its aging could occur. This has a negative effect on the service life of the drive. Furthermore, the thermal winding protection may force the drive to shut down the drive has reached its nominal values.

Determine the cleaning interval according to the expected operating conditions, but it should be every 12 months at the latest. Clean the drive according to the following instructions.

**WARNING! Moving machine parts can cause serious injuries or even death!** Before performing work, switch off the machine with the main switch and secure the switch from being turned on again.

**WARNING! Falling gravity-loaded axes or vertical axes can cause serious injuries or even death!** Move gravity-loaded axes or vertical axes to their lowest position and lock or brace them mechanically before entering the danger area.

**CAUTION! The surface of the drive can reach temperatures over 65 °C during operation!** Allow the drive to cool sufficiently before working on it. Wear gloves.

**ATTENTION! Improper cleaning can cause damage to the gear unit/geared motor!** Do not use steam jet cleaners, high-pressure cleaners or compressed air to clean the gear unit/geared motor, as this can result in water and dirt entering the interior of the gear unit/geared motor through the seals and can damage it. In addition, do not use solvents, as these can damage the seals and the nameplate. Comply with the following instructions.

- Remove dust and chips with a suitable industrial vacuum.
- Remove contamination from the surface of the drive with a suitable industrial cleaner.

### 7.2 Inspection

Perform regular inspections on the gear unit in accordance with the following specifications. Inspect the attached motor in accordance with the documentation of the motor manufacturer.

**WARNING! Moving machine parts can cause serious injuries or even death!** Before performing work, switch off the machine with the main switch and secure the switch from being turned on again.

**WARNING! Falling gravity-loaded axes or vertical axes can cause serious injuries or even death!** Move gravity-loaded axes or vertical axes to their lowest position and lock or brace them mechanically before entering the danger area.

**CAUTION! The surface of the drive can reach temperatures over 65 °C during operation!** Allow the drive to cool sufficiently before working on it. Wear gloves.

Interval	Task
Every 3000 operating hours or every 6 months	Check shaft seal rings for external damage and leaks
Annually	Check paint for damage and touch up if necessary
	Check tightening torques of the screw connections between gear unit/machine and between gear shaft/drive elements (see chapter <a href="#">Tightening torques [▶ 35]</a> )
Every 10000 operating hours	Change the oil for the K5 – K10 gear unit (see chapter <a href="#">Changing the oil [▶ 38]</a> )

## 7.2.1 Changing the oil

You can find information on the oil change for K5 – K10 gear units in this chapter. K1 – K4 gear units are lubricated for their entire service life and do not require an oil change.

The gear units are filled with synthetic gear oil at the factory. The oil fill volume depends on the mounting position of the gear unit.

The specification and fill volume of the gear oil is specified on the nameplate of the gear unit and in the documentation (see chapter [Additional documentation](#) [▶ 15])

Depending on the mounting position of the gear unit, the filling and draining connections are on different gear unit sides. Details on this can be found in the following figures.

The following equipment is required for the oil change:

- A sufficiently large collection container for the used oil
- Rubber gloves and safety glasses with side protection
- Hex key
- Open-end wrench

Proceed as follows for the oil change:

1. If the gear unit was in operation immediately beforehand, allow it to cool.
2. De-energize the machine drives and secure them from unintentional activation.
3. Wear rubber gloves and safety glasses with side protection.
4. Ensure access to the filling and draining connections of the gear unit (see the following figures).
5. Place the collection container under the draining connection.
6. Slowly unscrew the screw plug on the draining connection using a hex key.
7. Use an open-ended wrench to unscrew the air release valve on the filling connection and wait until the used oil has completely drained from the gear unit.
8. Close the draining connection and remove the collection container.
9. Use the filling connection to fill the gear unit with the oil volume and oil specification indicated on the nameplate.
10. Close the filling connection.
11. Dispose of the used oil properly.

### Filling and draining connections for K513 – K1013 gear units

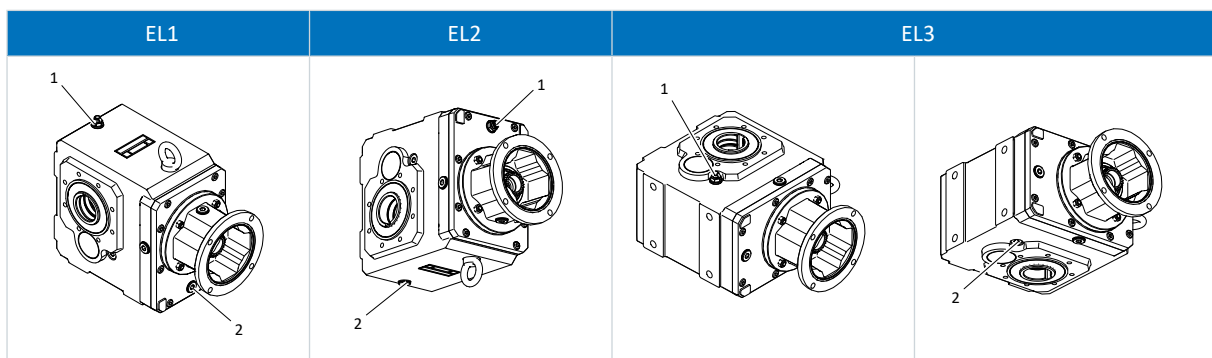

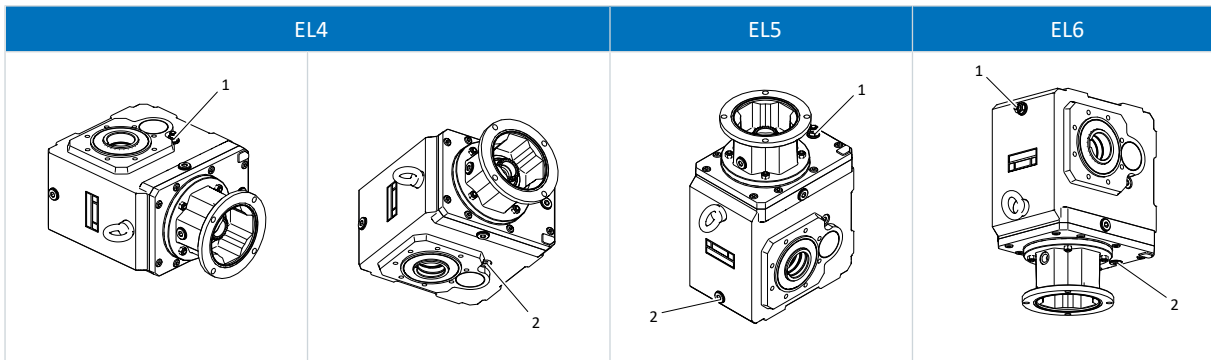

1 Air release valve (filling connection)

2 Screw plug (draining connection)

### Filling and draining connections for K514 – K1014 gear units

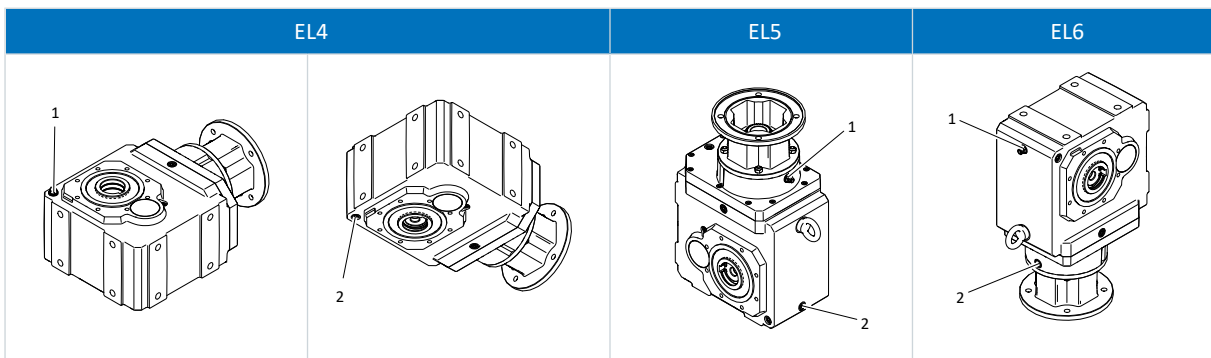
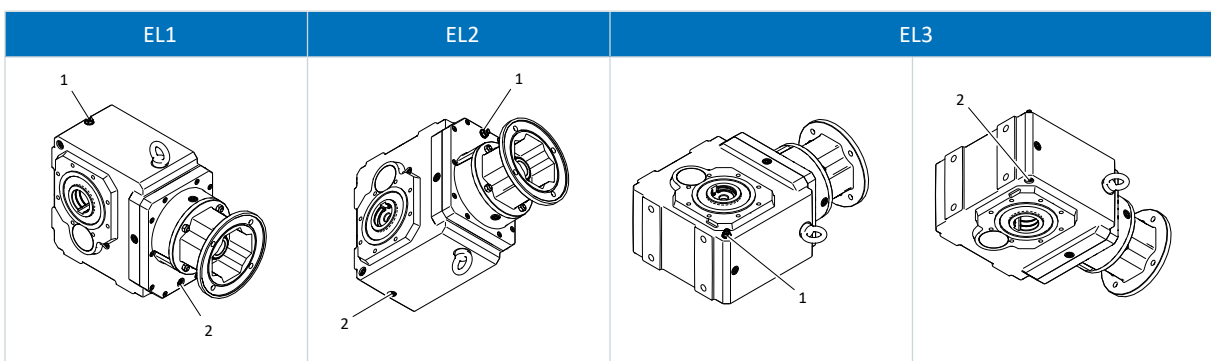

1 Air release valve (filling connection)

2 Screw plug (draining connection)

For K514 gear units in the EL5 and EL6 mounting positions, the filling and draining connections are arranged as they are for K513 gear units in EL5 and EL6.

## 7.3 Remediating faults

**WARNING! Moving machine parts can cause serious injuries or even death!** Before performing work, switch off the machine with the main switch and secure the switch from being turned on again.

Notify all personnel working on the machine or the drive of deviations from normal operation. These deviations indicate that the function of the drive is impaired. These include:

- Higher operating temperatures or increased vibrations
- Unusual noises or smells
- Triggering of monitoring systems
- Leaks on the housing of the gear unit

In such an event, shut down the drive and notify the responsible service personnel immediately.

### 7.3.1 Troubleshooting faults

The following table describes faults that can occur during the operation of the gear unit. Read through the table from top to bottom when troubleshooting faults.

Faults	Possible causes	Actions
Operating temperature is higher or exceeds the permitted temperature of the gear unit	Speed or torque is too high	Check the design of the gear unit
	Motor heats the gear unit (too much)	Cool the motor sufficiently
		Check the wiring of the motor
	Replace the motor	
Surrounding temperature is too high	Provide sufficient cooling for the gear unit	
Bearing damage	Contact STOBBER Service	
Increased or different noises or vibrations in operation	Motor is mounted with too much tension	Check the assembly of the motor
	Gear unit is mounted incorrectly or with too much tension	Check the assembly of the gear unit
	Bearing damage	Contact STOBBER Service
	Gear damage	Contact STOBBER Service
Leaks	Radial shaft seal ring leaks	Contact STOBBER Service
	Output shaft damaged at the sealing point	Contact STOBBER Service
	Increased inner pressure due to operating temperature that is too high	See measures in case of fault <a href="#">Operating temperature is higher ... of the gear unit</a>
	Gear housing leaks	Contact STOBBER Service
Output shaft does not turn although motor is running	Clamp coupling is defective or tightened incorrectly	Check the clamp coupling

## 7.4 Servicing

Have the necessary servicing work carried out on the drive by the STOBBER Service department or by STOBBER service partners. Be aware that improper servicing may cause material damage and may void the manufacturer's warranty.

Only use replacement parts delivered by STOBBER. Specify the type designation and serial number of the drive when ordering replacement parts. These can be found on the nameplate of the drive.



## 7.5 Service

If you contact STÖBER Service, have the following information ready:

- Serial number and type designation of the drive according to the nameplate
- Type of fault and surrounding circumstances
- Presumed cause
- If possible, digital photo of the drive or a video recording of the drive in the context of the fault

### **Contact data of parent company in Germany**

STÖBER Antriebstechnik GmbH + Co. KG

Kieselbronner Strasse 12

75177 Pforzheim

Germany

Service hotline: +49 7231 582-3000

mail@stoeber.de

### **Contact data of subsidiary in US**

STOBER Drives Inc.

1781 Downing Drive

Maysville, KY 41056

Service Hotline +1 606 563-6035

service@stober.com

## 8 Removal and disposal

### 8.1 Removal

Remove the drive as follows:

1. If the drive had been in operation immediately beforehand, allow it to cool.
2. Disconnect the connection cable and the grounding conductor from the motor.
3. For gear units with a solid shaft: If necessary, remove drive elements connected to the solid shaft, such as belts, chains or couplings, with suitable removal devices.
4. Unscrew the screws used to mount the drive to the machine.
5. For gear units with a hollow shaft and shrink ring: Unscrew the clamping screws of the shrink ring in multiple cycles by one quarter rotation each in turn, but do not completely remove the clamping screws from the thread. Remove the gear unit from the machine shaft.
6. For gear units with a hollow shaft and keyway: Remove the hollow shaft from the machine shaft (see chapter [Removing a hollow shaft with keyway](#) [▶ 42]).
7. Detach the gear unit from the machine.
8. If necessary, remove the motor from the gear unit. To do so, unscrew the screws of the motor used to mount the motor to the gear unit and detach the motor from the gear unit.

#### 8.1.1 Removing a hollow shaft with keyway

This chapter contains instructions for removing a gear unit with a hollow shaft and keyway from the machine shaft.

##### Tools

The following tools, not included in the scope of delivery of the gear unit, are required for removal:

- Keeper plate
- Set screw for removing the hollow shaft
- Hex wrench that fits the set screw

Ødh [mm]	20 <sup>H7</sup>	25 <sup>H7</sup>	30 <sup>H7</sup>	35 <sup>H7</sup>	40 <sup>H7</sup>	50 <sup>H7</sup>	60 <sup>H7</sup>	70 <sup>H7</sup>	90 <sup>H7</sup>	100 <sup>H7</sup>
sas	M8	M12	M12	M16	M20	M20	M24	M24	M30	M30

Tab. 7: Specifications for the set screw

Dimension name	Explanation
Ødh	Inner diameter of the hollow shaft
sas	Thread diameter in the keeper plate

##### Procedure

1. Use the hex wrench to screw the set screw (3) into the threaded hole of the keeper plate (4) until the set screw presses against the machine shaft (5).
2. Tighten the set screw until the hollow shaft (2) releases from the machine shaft.
3. Remove the gear unit from the machine.
4. Unscrew the set screw from the threaded hole of the keeper plate.

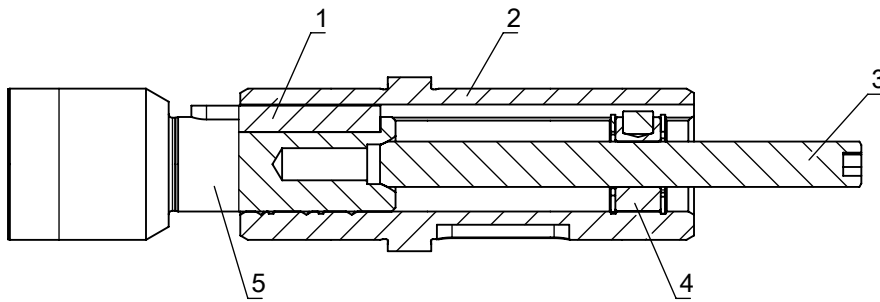

1	Feather key	2	Hollow shaft
3	Set screw	4	Keeper plate
5	Machine shaft		

## 8.2 Disposal

Dispose of the component parts of the gear unit according to applicable national regulations and when doing so, observe the following information:

- If possible, separate the gear unit into component parts made of steel/cast iron, aluminum and plastic.
- The gear unit contains lubricants (oil or grease) that pose a risk to the environment and to health. Collect the used oil and grease without mixing them and dispose of them properly.



4 4 3 3 6 4 E N . 0 0

07/2023

STÖBER Antriebstechnik GmbH + Co. KG  
Kieselbronner Str. 12  
75177 Pforzheim  
Germany  
Tel. +49 7231 582-0  
mail@stoeber.de  
www.stober.com

24 h Service Hotline  
+49 7231 582-3000

[www.stober.com](http://www.stober.com)