

1 Safety information

1.1 General safety instructions

WARNING!

When connecting and operating the motors considerable hazards to the life and health of persons may occur!

- ▶ When connecting the motor observe the following safety instructions, the operating instructions for the motor and applicable national, local and system-specific regulations.
-

1.2 Safety when making the electrical connection

WARNING!

Electrical shock by touching live unpainted parts of the motor!

- ▶ The electrical connection of the motor may only be carried out by a qualified electrician.
 - ▶ Before connecting the motor, switch the relevant system or machine to zero potential with the main switch and protect the main switch against being turned on again!
 - ▶ Close the entire connector housing before turning on the motor.
 - ▶ Do not touch the motor connections while the motor shaft is rotating, as due to the built-in permanent magnets a voltage is applied to the motor connections.
-

1.3 Avoid connection errors

NOTICE

Electrical connection errors can cause damage to the motor and its components.

- ▶ Make sure that the cables and connectors to be connected meet this motor connection plan.
 - ▶ Carefully note the information on the motor name plate and this motor connection plan. For questions please contact STÖBER Service department.
-

1.4 Risks of noncoordinated third-party components

NOTICE

If connection cables or a drive controller that are not designed for the motor are used to make the electrical connection for the motor, this may result in damage to the motor or that compliance with the legal requirements for EMC is no longer provided and claims under the warranty will be null and void.

- ▶ You should use connection cables and a drive controller specifically designed for your motor from the STÖBER product range.
-

1.5 Applied standards

Colors are coded as per IEC 60757 and are only relevant for the internal motor connection strands.

2 Motor connection

2.1 Power connection

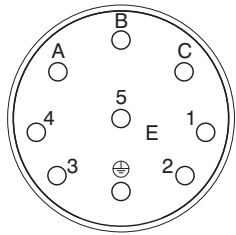
Connection diagram	Pin	Connection	Color
 <p>Size con.15</p>	A	1U1 (phase U)	BK
	B	1V1 (phase V)	BU
	C	1W1 (phase W)	RD
	1	1TP1 ²⁾	
	2	1TP2 ²⁾	
	3	1BD1 ¹⁾	
	4	1BD2 ¹⁾	
⊕	Protective conductor	GNYE	

1) see chapter "Motor holding brake"

2) see chapter "Temperature sensor"

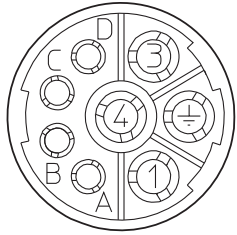
Connection diagram	Pin	Connection	Color
 <p>Size con.23 (1)</p>	1	1U1 (phase U)	BK
	3	1W1 (phase W)	RD
	4	1V1 (phase V)	BU
	A	1TP1 / 1K1 ²⁾	
	B	1TP2 / 1K2 ²⁾	
	C	1BD1 ¹⁾	
	D	1BD2 ¹⁾	
⊕	Protective conductor	GNYE	

1) see chapter "Motor holding brake"

2) see chapter "Temperature sensor"

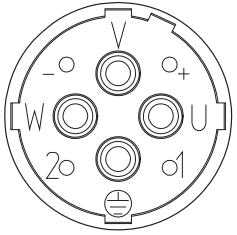
Connection diagram	Pin	Connection	Color
 <p>Size con.40 (1,5)</p>	U	1U1 (phase U)	BK
	V	1V1 (phase V)	BU
	W	1W1 (phase W)	RD
	+	1BD1 ¹⁾	
	-	1BD2 ¹⁾	
	1	1TP1 / 1K1 ²⁾	
	2	1TP2 / 1K2 ²⁾	
⊕	Protective conductor	GNYE	

1) see chapter "Motor holding brake"

2) see chapter "Temperature sensor"

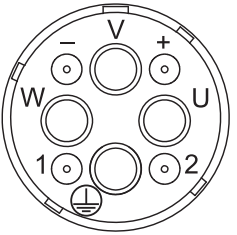
Connection diagram	Pin	Connection	Color
 <p>Size con.58 (3)</p>	U	1U1 (phase U)	BK
	V	1V1 (phase V)	BU
	W	1W1 (phase W)	RD
	+	1BD1 ¹⁾	
	-	1BD2 ¹⁾	
	1	1TP1 / 1K1 ²⁾	
	2	1TP2 / 1K2 ²⁾	
⊕	Protective conductor	GNYE	

1) see chapter "Motor holding brake"

2) see chapter "Temperature sensor"

2.2 Temperature sensor

NOTICE

The temperature sensor can be damaged by electrical connection errors!

- Carefully note the type of the temperature sensor indicated on the motor name plate.

Pt1000 temperature sensor

Abbreviation	Color
1TP1	RD
1TP2	WH

2.3 Motor holding brake (optional)

NOTICE

The brake can be damaged by electrical connection errors!

- When connecting the brake, carefully note the polarity of the connections and the supply voltage of the brake.

Permanent magnet brake (P)

Abbreviation	Designation	Color
1BD1	DC 24 V \pm 5 % (smoothed)	RD
1BD2	0 V (GND)	BK

2.4 External fan connection (optional)

NOTICE

The external fan motor can be damaged by electrical connection errors!

- Check before making the connection whether the connection values and terminal assignment of the external fan motor match those shown below.

Connection diagram	Pin	Designation
	1	L1 (230 V ± 5 %, 50/60 Hz)
	2	N
	3	
	⊥	Protective conductor

2.5 Encoder connection

NOTICE

The encoder can be damaged by electrical connection errors!

- Check before making the connection, whether the type of the encoder specified on the name plate of the motor is correctly set in the drive controller.

Absolute value encoder EnDat 2.2 digital

Connection diagram	Pin	Signal	Color
	1	Up +	BNGN
	2	Data +	GY
	3	Data -	PK
	4	Clock +	VT
	5	Clock -	YE
	6		
	7	0 V	WHGN
	8		
	9		
	10		
	11		
	12		