

PHQK Series: RIGHT ANGLE – Flange Output

PHQK Series Dimensions – All Units

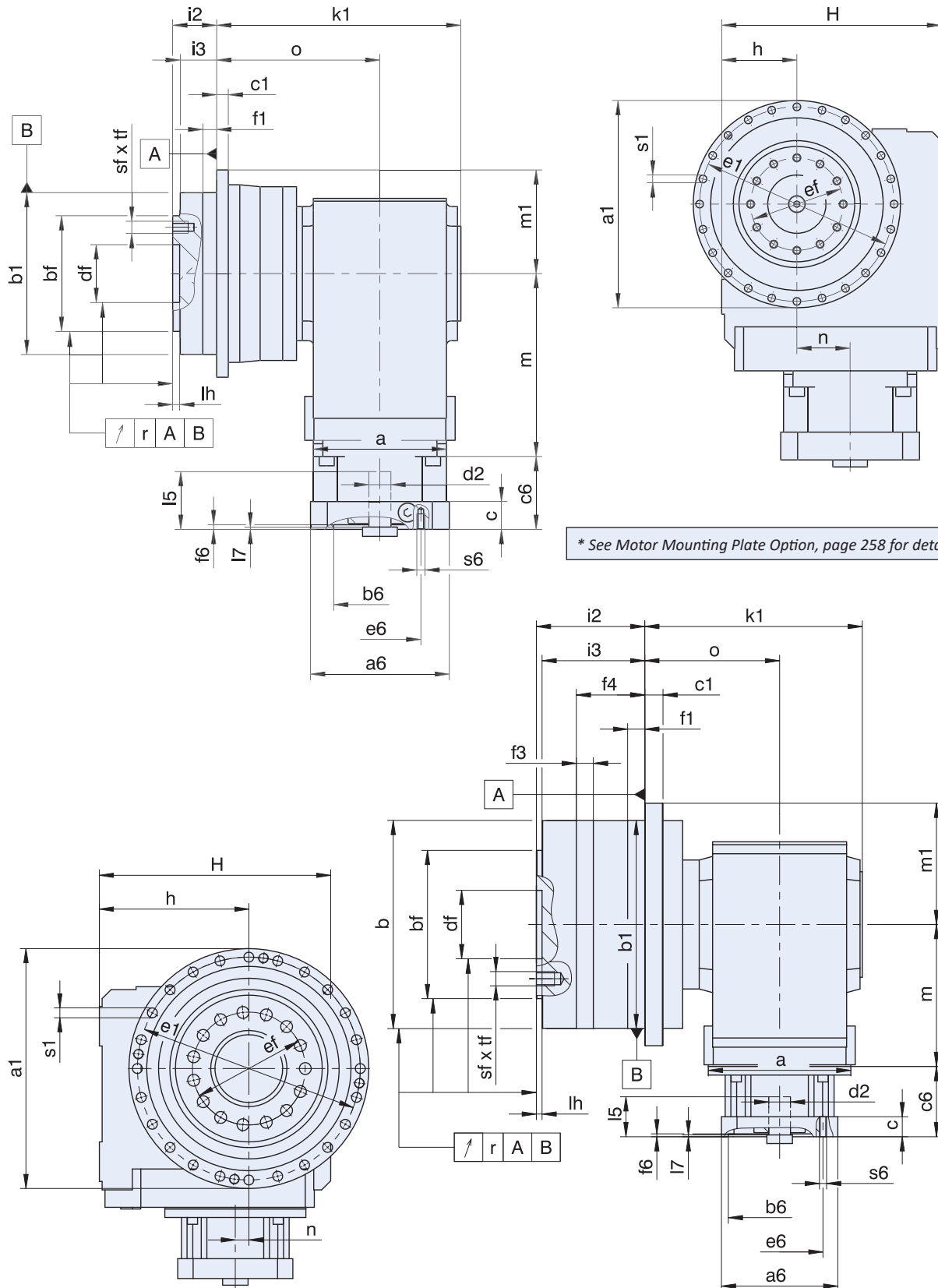

Dimensional Data

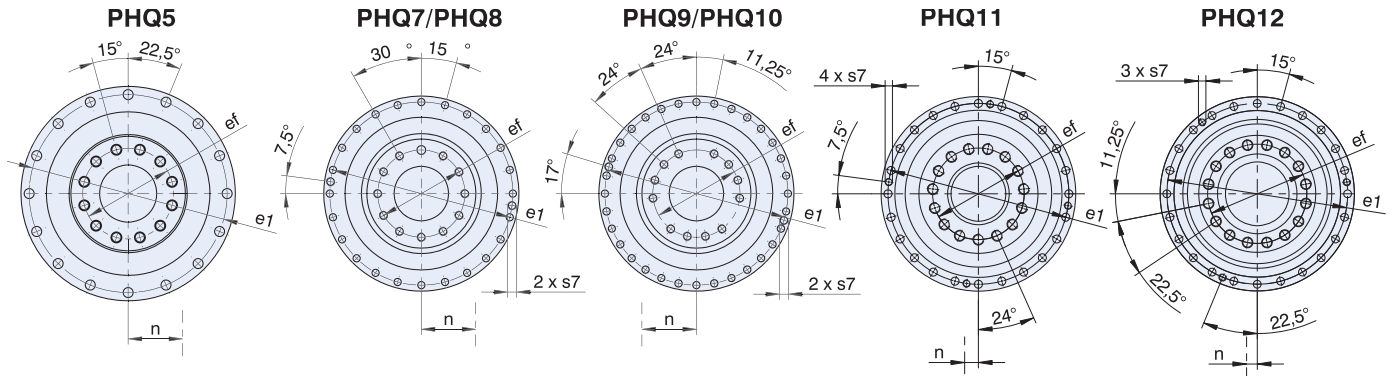

Table 1 Dimensions (mm)

Unit	Øa1	Øb	Øb1	Øbf	c1	Ødf	Øe1	Øef	f1	f3	f4	h	H	i2	i3	k1	lh	m1	o	r	Øs1	s7	sf	tf
PHQ531_K102	145 ^{h7}	–	110 ^{h7}	80 ^{h7}	8	40 ^{H6}	135	63	10	–	–	60	160	29	23	180.0	6	72.5	124.0	0.020	5.5	–	M8	11
PHQ731_K202	179 ^{h7}	–	140 ^{h7}	100 ^{h7}	10	50 ^{H6}	168	80	12	–	–	65	190	38	32	216.0	6	89.5	146.0	0.025	6.6	–	M10	16
PHQ831_K402	247 ^{h7}	–	200 ^{h7}	160 ^{h7}	12	80 ^{H6}	233	125	15	–	–	90	240	50	42	289.0	8	123.5	199.0	0.030	9.0	M10	M12	17
PHQ931_K513	300 ^{h7}	–	255 ^{h7}	180 ^{h7}	18	90 ^{H6}	280	145	20	–	–	160	260	66	55	292.5	12	150.0	196.5	0.030	13.5	M8	M20	28
PHQ1031_K713	330 ^{h7}	–	285 ^{h7}	200 ^{h7}	20	95 ^{H6}	310	166	20	–	–	212	342	75	60	344.5	10	165.0	228.0	0.040	13.5	M10	M24	35
PHQ1131_K813	425 ^{h7}	365 ^{H6}	365 ^{H6}	260 ^{h7}	32	120 ^{H6}	395	200	30	30	120	265	410	190	180	381.5	10	212.5	236.5	0.040	17.5	M16	M24	35.5
PHQ1231_K913	550 ^{h7}	470 ^{H6}	470 ^{H6}	330 ^{h7}	45	180 ^{H7}	510	280	30	30	145	315	495	206.5	195.5	452.0	10	275.0	282.0	0.040	22.0	M16	M30	48

Motor Mounting Plate

Table 2 Dimensions (mm)

Base Module	Motor Adapter Code															Wt. lbs.									
	ME10			ME20			ME30			ME40			ME50												
	a	m	n	a	m	n	a	m	n	a	m	n	a	m	n										
PH531_K102	98	124	36	115	128	36	–	–	–	–	–	–	–	–	–	–	–	–	–	–	–	–	–	43	
PH731_K102	98	143	46	115	147	46	145	149	46	–	–	–	–	–	–	–	–	–	–	–	–	–	–	–	53
PH731_K202	–	–	–	160	187	60	145	189	60	190	192	60	–	–	–	–	–	–	–	–	–	–	–	–	69
PH831_K202	–	–	–	160	172	15	145	174	15	190	177	15	–	–	–	–	–	–	–	–	–	–	–	–	116
PH831_K302	–	–	–	–	–	–	200	221	20	190	224	20	300	237	20	–	–	–	–	–	–	–	–	–	134
PH931_K513	–	–	–	–	–	–	200	247	24	250	249	24	300	262	24	–	–	–	–	–	–	–	–	–	213
PH1031_K613	–	–	–	–	–	–	–	–	–	250	294	25	300	307	25	–	–	–	–	–	–	–	–	–	310

PHQK Series: RIGHT ANGLE – Flange Output