

PHK Series: RIGHT ANGLE – Flange Output

PHK Features

- 16:1 to 591:1 ratios (higher ratios available. Contact STÖBER.)
- Quiet running (<63dB(A))
- High load capacity and tilting rigidity through symmetrical bearing arrangement
- FKM seals for extended gearbox life
- Large motor input option to accept bigger diameter motor shafts so you don't use an oversized gearbox
- Error free motor mounting and quick changeover with toleranced pilot on motor plate
- Low no load running torque, giving you more torque for your application
- Magnetic oil filtration to remove contaminants to prevent breakdowns
- Build and ship in one day
- Assembled in the USA

STÖBER PHK provides a right angle option with planetary gearing. The PHK provides a more compact, precise solution, and can handle higher input speeds. Every gearbox is made to order. STÖBER will custom whatever you need to fit your application. Contact us today to learn more.

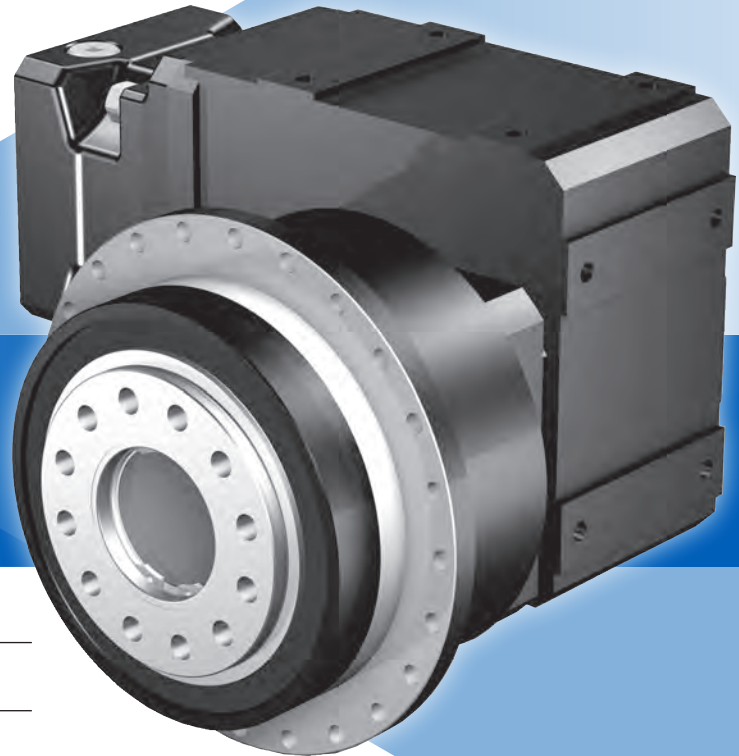

**SHIPS in
1 DAY!**
NO EXPEDITE FEE FOR 24
HOUR SERVICE

General Specifications

Ambient Temperature	0°C to +40°C (104°F) [Unit temperature <90°C Max]
Backlash	≤3.5 (see performance overview chart, page 238)
Coating	Standard Black (RAL-9005)
Degree of Protection	IP65
Direction of Rotation	See page 239
Efficiency	94%
Input RPM	Up to 6,000 RPM
Installation	Requires 12.9 fasteners. See page 306, for more information
Lubrication	Lubricated for life – standard Mobil SHC629; option food grade Mobil SHC CIBUS 150
Mounting Position	Must be specified, see page 239
Warranty	5 Year Limited (2 Years on normal wear items: bearings, seals, etc.)



Overview

Selection Options At-a-Glance

Using the **Selection Data** table later in this section, select the PHK Series Gearhead with the appropriate performance and design options tailored to your motor choice and exact application requirements. Use the part number guide below as a reference to build a part number for the complete gearhead assembly.

Part Number Examples:

PHK 1 2 3 4 5 6 7 8 9 0 ! @ EL1*

PH 5 3 1 S F S S 0040 K102VF 0040 ME10 EL1*

Design Option	Part Number Code	Description
1 Series	PH	Rotating flange output planetary
2 Size	5 7 8 9 10	5 sizes of gearhead
3 Generation	3	Version of gearhead
4 # of Stages	1	One stage for ratios of ≤ 10:1
5 Housing	S	Standard mounting style
6 Output Shaft	F	Flange output
7 Bearing	S V	Standard (Size 5-8 only) Reinforced Bearing (Size 5)
8 Backlash	S	Standard Backlash (Size 5-8 only)
9 Ratio	0030	Ratios range from 3:1 to 100:1 (0040=4:1; 0055=5.5:1; 1000=100:1, ect.)
0 Secondary Unit	K102VF	K Series helical/bevel unit: 5 sizes, 2 or 3 stages, with output shaft (V) and flange (F)
! Secondary Unit Ratio	0010	Ratios from 4:1 to 78:1 (0010=1:1; 0020=2:1; 0030=3:1)
@ Motor Adapter	ME10 - ME50 MB	Motor Adapter with EasyAdapt coupling ServoStop with motor adapter with brake (Contact factory)
* Mounting Position	EL1 EL2 EL3 EL4 EL5 EL6	Required special instruction for all units, see page 239

PHK Series: RIGHT ANGLE – Flange Output

Options

ME Adapter Option

- MSS1 Seal – special input seal for longer life (For sizes P5-9). Contact factory for this option.
- Peak Torque Booster – pinion securing element for shock loads, increasing peak torque up to 80%.

Integrated Safety Brake

- ServoStop – provides dynamic braking during power failures or emergency stops in hazardous situations. Contact factory for this option.

Coating Option

- Available with multi-layer, industrial 316 stainless steel epoxy coating. Contact factory for this option.

ATEX

- ATmosphere EXplosible – rated for explosive environments. Contact factory for this option and allow additional time for delivery.

PHK Series: RIGHT ANGLE – Flange Output

PHK Performance Overview

PHK Series performance is dependent on several factors including duty cycle, bearing design, gearhead size and stage configuration, among others. Use the chart below for preliminary evaluation, then use the following performance chart and selection information on the following pages for specific performance sizing and selection.

Size/Generation/# of Stages		PH521	PH721		PH821		PH931	PH1031
Secondary Unit		K102	K102	K202	K202	K302	K513	K613
Acceleration Torque M_{2BMAX}	Nm	385	869	882	1478	1848	4500	7500
Output Torque Nom. ¹ M_{2N}	Nm	220	440		1000	1100	3000	5000
Torsional Stiffness C_2	Nm/arcmin	62	11	117.0	260	245	730	1210
Torsional Backlash ² $\Delta\phi$	arcmin	≤4	≤4		≤3.5	≤4	≤4	≤4
Input Speed Max. n_{1MAX}	Continuous	4000	4000	4000	4000	3800	3400	3100
	Cyclic	7000	7000	6500	6500	6000	5000	4500
Efficiency (@nom torque)	%	93	93		93		92	92
Weight	kg	18	22.2	32.6	51	56	95.6	147.6
	lbs	39.6	48.8	71.7	112.2	123.2	210.3	324.7
Noise ³	dB(A)	≤63	≤63	≤64	≤64	≤65	≤65	≤65
Performance by Bearing Design Option ⁴								
Permitted Axial Force F_{2ax100}	N	4150	6150		10,050		33,000	50,000
Permitted Tilting Torque M_{2K100}	Nm	440	1466		3486		7500	8800
Performance by Reinforced Bearing Design Option – Choose V Option ⁴								
Permitted Axial Force F_{2ax100}	N	5000	—		—		—	—
Permitted Tilting Torque ≤100RPM M_{2K100}	Nm	572	—		—		—	—

¹) Ratings based on input speed (n_1) of 1500 RPM.

To calculate torque at higher input speeds, contact the factory.

²) Tested at 1.5% of nominal torque and recorded on the output side of the gearhead. For lower backlash, contact STÖBER technical support.

³) Measurement at one (1) meter distance with input speed (n_1) of 1500 RPM.

⁴) Rating based on output speed (n_2) of 100 RPM. For values at other speeds see page 241.

Overview



PHK Series Direction of Rotation

For PHK units, the "PH" Series planetary output unit can be mounted on either the right (Side 3) or the left (Side 4) of the "K" Series right angle secondary unit. Note CCW input direction of rotation and CW output shaft direction with both mounting configurations.

IMPORTANT: When ordering, Mounting Side 3 or Side 4 **MUST BE SPECIFIED.**

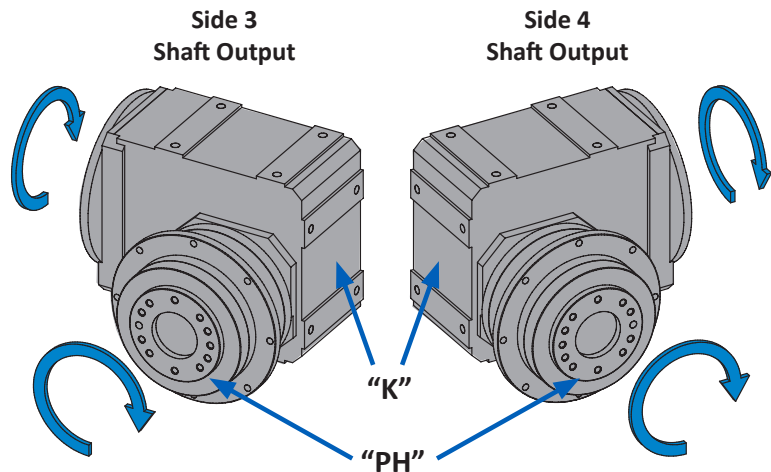

PHK Series: RIGHT ANGLE – Flange Output

PHK Mounting Position Options

When ordering, the Mounting Position **MUST BE SPECIFIED** using one of the Mounting Position order codes below.

Note: the code relates to the orientation side that faces down. For example, EL1 has side 1 facing down, EL2 has side 2 facing down, etc.

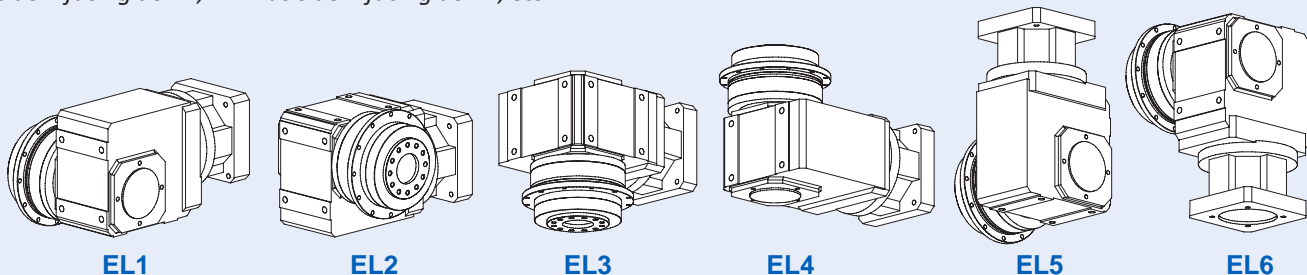
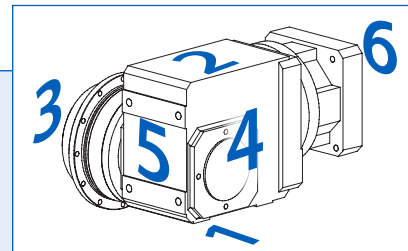

PHK Series Motor Mounting Plate Access Hole

Access to the clamping screw for the motor coupling is located on the 270° side of the motor mounting plate at the location shown. If necessary, the motor mounting plate can be rotated in the field, if a 0°, 90° or 180° orientation for the access hole is desirable.

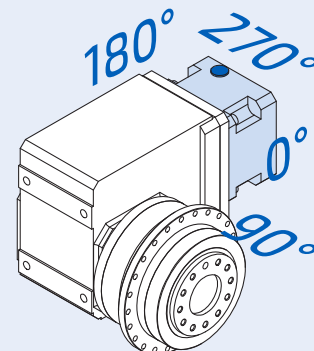

PHK Series: RIGHT ANGLE – Flange Output

PHK Series Motor Mounting Plate Option

STOBER Servo Gearheads fit the motor of your choice with the appropriate motor mounting plate assembled between the motor and the gearhead.

NOTE: When ordering a gearhead:

- Specify the motor manufacturer and part number
- Provide the motor drawing with dimensions, or specify the motor mounting dimensions (per the list shown at right)

For a precise dimension on a specific motor, or for general assistance, we recommend you contact STOBER Technical Support.

Customer Required Dimensions for Properly Sized Motor Mounting Plate

Motor information required with Motor Adapter (MF option for PHKX; ME option for PHK and PHQK)

- d2 Motor Shaft Diameter (If an adapter bushing is required it will be supplied with the motor plate.)
- b6 Pilot Diameter
- e6 Bolt Circle Diameter
- s6 Bolt Diameter
- l5 Motor Shaft Length
- f6 Pilot Length
- a6 Square Flange (Optional – motor plate will typically be made to match this dimension.)

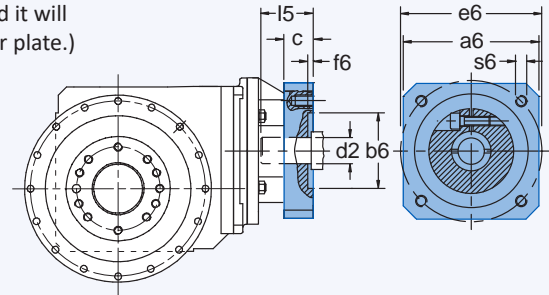

PHK Motor Mounting Plate Dimensions — mm (Gearhead Part Number Specific)

	ME10	ME20	ME30	ME40	ME50
Maximum Allowed Motor Shaft Dia. d2	19	32	38	48	60
Minimum Allowed Motor Plate Thickness c*	21	24	25	33	43

* Note that the c motor plate thickness is determined by the motor shaft length. The minimum motor plate thickness is the value listed.

PHK Series Permissible Motor Tilting Torque

The permissible tilting torque of the motor attached to the gear unit is a result of the static and dynamic load “F” from the motor weight, mass acceleration, and vibration multiplied by the distance from the center of gravity “l_s” of the motor.

M _{1k}	PHQK (ME Motor Adapters)				
	ME10	ME20	ME30	ME40	ME50
Nm	25	60	125	250	600

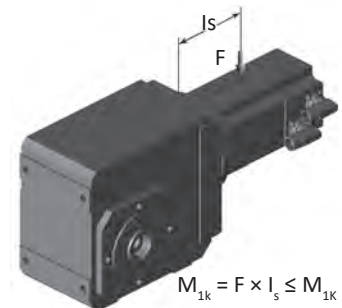



Overview

PHK Series Permissible Output Shaft Load and Tilting Moments – Standard Bearings

Size	Z ₂ Distance of Shaft Shoulder to Center of Output Bearing mm	F _{2ax100} Permitted Axial Force N	F _{2rad100} Permitted Radial Force ≤100RPM N	F _{2rad,acc} Radial Acceleration Force N	M _{2K100} Permitted Tilting Torque ≤100RPM Nm	M _{2K,acc} Permitted Acceleration Tilting Torque Nm	C _{2K} Tilting Stiffness Nm/arcmin
5	97.0	4150	4536	4897	475	475	429
7	86.0	6150	17,045	17,045	1466	1466	500
8	125.5	10,050	27,778	27,778	3486	3486	1550
9	155.0	33,000	48,387	70,968	7500	11,000	7500
10	171.0	50,000	51,462	73,099	8800	12,500	9500

PHK Series Permissible Output Shaft Load and Tilting Moments – Reinforced Bearings

Size	Z ₂ Distance of Shaft Shoulder to Center of Output Bearing mm	F _{2ax100} Permitted Axial Force N	F _{2rad100} Permitted Radial Force ≤100RPM N	F _{2rad,acc} Radial Acceleration Force N	M _{2K100} Permitted Tilting Torque ≤100RPM Nm	M _{2K,acc} Permitted Acceleration Tilting Torque Nm	C _{2K} Tilting Stiffness Nm/arcmin
5	104.0	5000	5500	5500	572	572	478

PHK Series: RIGHT ANGLE – Flange Output

PHK Series Load/Life/Speed Calculations

The permissible load and tilting moment values are based on an output speed of 100 RPM. For higher speeds the following applies, where n_2 is the desired speed:

$$F_{2radN} = \frac{F_{2rad100}}{\sqrt[3]{\frac{n_{2m} \cdot n_2}{100rpm}}} \quad F_{2ax} = \frac{F_{2ax100}}{\sqrt[3]{\frac{n_2}{100}}} \quad M_{2KX} = \frac{M_{2K100}}{\sqrt[3]{\frac{n_2}{100}}}$$

The application output tilting moment should be determined by the following formula:

$$M_{2k,acc*} = \frac{2 \cdot F_{2ax100*} \cdot y_2 + F_{2rad,acc*} \cdot (x_2 + Z_2)}{1000} \leq M_{2k,acc}$$

$$M_{2k,eq*} = \sqrt[3]{\frac{n_{2b1} \cdot t_{b1} \cdot M_{2kb1}^3 + \dots + n_{2bn} \cdot t_{bn} \cdot M_{2kbn}^3}{n_{2b1} \cdot t_{b1} + \dots + n_{2bn} \cdot t_{bn}}} \leq M_{2kN}$$

$$F_{2rad,eq*} = \sqrt[3]{\frac{n_{2b1} \cdot t_{b1} \cdot F_{2rb1}^3 + \dots + n_{2bn} \cdot t_{bn} \cdot F_{2rbn}^3}{n_{2b1} \cdot t_{b1} + \dots + n_{2bn} \cdot t_{bn}}} \leq F_{2radN}$$

Where:

- Z₂ Distance of Shaft Shoulder to Center of Output Bearing
- n₂ Actual Average Output Speed
- X₂ Distance of the Shaft Shoulder to the Force Application Point
- Y₂ Distance of the Shaft Axis to the Axial Force Application Point
- F_{2ax*} Actual Axial Force at Gear Unit Output
- F_{2ax100} Permitted Axial Force
- F_{2rad100} Permitted Radial Force ≤100RPM
- F_{2rad,acc} Radial Acceleration Force
- F_{2rad,acc*} Radial Acceleration Force at Gear Unit Output
- M_{2K100} Permitted Tilting Torque ≤100RPM
- M_{2K,acc} Permitted Acceleration Tilting Torque
- M_{2k,acc*} Permitted Acceleration Tilting Torque at Gear Unit Output
- C_{2K} Tilting Stiffness

All formulas shown are based on METRIC values

Upper case letters are permissible values. Lower case letters are for existing values.

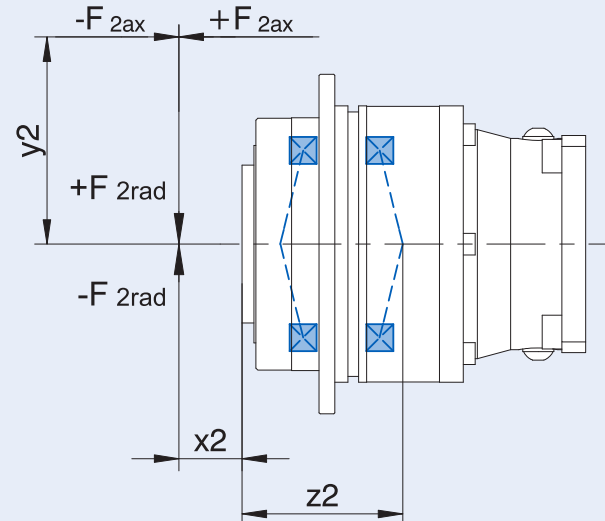

The hours of life (L_n) of the unit can be determined by the following formula:

bearing life for duty cycle ≤ 40%

$$L_n > 10,000 \text{ hours if } M_{2k100}/M_{2A*} < 1.25 \text{ and } > 1$$

$$L_n > 20,000 \text{ hours if } M_{2k100}/M_{2A*} > 1.25 \text{ and } > 1.5$$

$$L_n > 30,000 \text{ hours if } M_{2k100}/M_{2A*} < 1.5$$

bearing life for duty cycle ≥ 40%

$$L_{nA} = L_n \left(\frac{40\%}{\text{Duty Cycle}} \right)$$

PHK Series: RIGHT ANGLE – Flange Output

Reducer Ratio (i)		Output Torque			Backlash $\Delta\phi_2$	Part Number* (Gearhead + Input)	Max. Input Speed RPM (n1)			Motor Shaft ³⁾ Max ϕ d _{MW}	Input Inertia J ₁	Tors. Stiffness C ₂
		Nom. ¹⁾ M _{2N}	Accel. M _{2acc}	Peak ²⁾ M _{2NOT}			Continuous		Cyclic			
Nom.	Exact	Nm	Nm	Nm	arcmin		EL 1,2	EL 3,4,5,6	All	mm	kgcm ²	Nm/ arcmin

PH5K

16.00	16/1	210	355	485	4.5	PH531_0040K102_0040 ME10	3300	2800	5000	≤19	1.6	50
						PH531_0040K102_0040 ME20				≤24		51
20.00	20/1	220	385	606	4.0	PH531_0050K102_0040 ME10	3300	2800	5000	≤19	1.6	60
						PH531_0050K102_0040 ME20				≤24		61
27.84	7600/273	220	385	705	4.0	PH531_0050K102_0056 ME10	3300	2800	5000	≤19	1.3	61
						PH531_0050K102_0056 ME20				≤24		
30.00	30/1	220	385	705	4.0	PH531_0050K102_0060 ME10	3300	2800	5000	≤19	1.1	61
						PH531_0050K102_0060 ME20				≤24		
33.22	299/9	220	385	705	4.0	PH531_0050K102_0066 ME10	3600	3300	5500	≤19	1.1	61
						PH531_0050K102_0066 ME20				≤24		
41.55	1911/46	220	385	705	4.0	PH531_0050K102_0083 ME10	3600	3300	5500	≤19	0.93	61
						PH531_0050K102_0083 ME20				≤24		2.8
46.25	8740/189	220	385	705	4.0	PH531_0050K102_0092 ME10	3600	3300	5500	≤19	0.97	61
						PH531_0050K102_0092 ME20				≤24		2.9
57.83	1330/23	220	385	705	4.0	PH531_0050K102_0115 ME10	3600	3300	5500	≤19	0.88	62
						PH531_0050K102_0115 ME20				≤24		
70.57	494/7	220	385	705	4.0	PH531_0050K102_0140 ME10	4000	3800	6000	≤19	0.82	62
						PH531_0050K102_0140 ME20	3700	3700		≤24		
87.82	10450/119	220	385	705	4.0	PH531_0050K102_0175 ME10	4000	3800	6000	≤19	0.77	62
						PH531_0050K102_0175 ME20	3700	3700		≤24		
116.3	5700/49	220	385	705	4.0	PH531_0050K102_0230 ME10	4000	4000	7000	≤19	0.72	62
						PH531_0050K102_0230 ME20	3700	3700	6000	≤24		
140.2	2945/21	220	385	705	4.0	PH531_0050K102_0280 ME10	4000	4000	7000	≤19	0.70	62
						PH531_0050K102_0280 ME20	3700	3700	6000	≤24		
175.5	3686/21	220	385	705	4.0	PH531_0050K102_0350 ME10	4000	4000	7000	≤19	0.68	62
						PH531_0050K102_0350 ME20	3700	3700	6000	≤24		
234.6	11,495/49	220	385	705	4.0	PH531_0050K102_0470 ME10	4000	4000	7000	≤19	0.63	62
280.5	5890/21	220	385	705	4.0	PH531_0050K102_0560 ME10	4000	4000	7000	≤19	0.62	62

¹⁾ Based on input speed of 1500 RPM. See page 240 for details on torque calculations.

²⁾ Maximum momentary torque for emergency stops or heavy shock load. (Admissible stops per life of gearhead = 1,000 stops maximum.)

* Motor shaft adapter code (shaft diameter max - mm): ME10 (19), ME20 (32), ME30 (38), ME40 (48), ME50 (60)

Selection Data



Reducer Ratio (i)		Output Torque			Backlash $\Delta\phi_2$	Part Number* (Gearhead + Input)	Max. Input Speed RPM (n1)			Motor Shaft ³⁾ Max ϕ d_{MW}	Input Inertia J_1	Tors. Stiffness C_2
		Nom. ¹⁾ M_{2N}	Accel. M_{2acc}	Peak ²⁾ M_{2NOT}			Continuous		Cyclic			
Nom.	Exact	Nm	Nm	Nm	arcmin		EL 1,2	EL 3,4,5,6	All	mm	kgcm ²	Nm/arcmin

PH7K (continued next page)

16.00	16/1	440	670	1213	4.5	PH731_0040K202_0040 ME20	3000	2600	4500	≤32	6.8	99
						PH731_0040K202_0040 ME30				≤38	12	
20.00	20/1	440	838	1516	4.0	PH731_0050K202_0040 ME20	3000	2600	4500	≤32	6.6	116
						PH731_0050K202_0040 ME30				≤38	12	
25.89	10,535/407	440	882	1720	4.0	PH731_0050K202_0052 ME20	3000	2600	4500	≤32	5.8	116
						PH731_0050K202_0052 ME30				≤38	11	
28.00	28/1	438	626	849	4.0	PH731_0070K102_0040 ME10	3300	2800	5000	≤19	1.6	108
						PH731_0070K102_0040 ME20				≤24	3.5	109
30.00	30/1	440	670	909	4.0	PH731_0050K202_0060 ME10	3000	2600	4500	≤19	2.4	114
			882	1720		PH731_0050K202_0060 ME20				≤32	5.8	116
						PH731_0050K202_0060 ME30				≤38	11	
33.42	11,395/341	440	747	1013	4.0	PH731_0050K202_0067 ME10	3500	3100	5000	≤19	1.8	115
			882	1720		PH731_0050K202_0067 ME20				≤32	5.2	116
						PH731_0050K202_0067 ME30				≤38	11	117
38.98	1520/39	440	733	1181	4.0	PH731_0070K102_0056 ME10	3300	2800	5000	≤19	1.3	109
						PH731_0070K102_0056 ME20				≤24	3.2	110
40.00	40/1	350	575	1150	3.5	PH731_0100K102_0040 ME10	3300	2800	5000	≤19	1.5	104
						PH731_0100K102_0040 ME20				≤24	3.4	105
41.99	12,470/297	440	882	1273	4.0	PH731_0050K202_0084 ME10	3500	3100	5000	≤19	1.4	116
				1720		PH731_0050K202_0084 ME20				≤32	4.8	117
						PH731_0050K202_0084 ME30				≤38	10	
42.00	42/1	440	752	1273	4.0	PH731_0070K102_0060 ME10	3300	2800	5000	≤19	1.1	110
						PH731_0070K102_0060 ME20				≤24	3.0	
45.95	11,395/248	440	882	1393	4.0	PH731_0050K202_0092 ME10	3500	3100	5000	≤19	1.6	116
				1720		PH731_0050K202_0092 ME20				≤32	5.0	117
						PH731_0050K202_0092 ME30				≤38	10	
46.51	2093/45	440	778	1410	4.0	PH731_0070K102_0066 ME10	3600	3300	5500	≤19	1.1	110
						PH731_0070K102_0066 ME20				≤24	3.0	
55.68	15,200/273	350	575	1150	3.5	PH731_0100K102_0056 ME10	3300	2800	5000	≤19	1.3	105
						PH731_0100K102_0056 ME20				≤24	3.2	
57.73	6235/108	440	882	1720	4.0	PH731_0050K202_0115 ME10	3500	3100	5000	≤19	1.3	116
						PH731_0050K202_0115 ME20				≤32	4.7	117
						PH731_0050K202_0115 ME30				≤38	10	

PHK Series: RIGHT ANGLE – Flange Output

¹⁾ Based on input speed of 1500 RPM. See page 240 for details on torque calculations.

²⁾ Maximum momentary torque for emergency stops or heavy shock load. (Admissible stops per life of gearhead = 1,000 stops maximum.)

* Motor shaft adapter code (shaft diameter max - mm): ME10 (19), ME20 (32), ME30 (38), ME40 (48), ME50 (60)

PHK Series: RIGHT ANGLE – Flange Output

Reducer Ratio (i)		Output Torque			Back-lash $\Delta\phi_2$	Part Number* (Gearhead + Input)	Max. Input Speed RPM (n1)			Motor Shaft ³⁾ Max ϕ d _{MW}	Input Inertia J ₁	Tors. Stiffness C ₂
		Nom. ¹⁾ M _{2N}	Accel. M _{2acc}	Peak ²⁾ M _{2NOT}			Continuous		Cyclic			
Nom.	Exact	Nm	Nm	Nm	arcmin		EL 1,2	EL 3,4,5,6	All	mm	kgcm ²	Nm/ arcmin

PH7K (continued next page)

58.16	13,377/230	440	838	1545	4.0	PH731_0070K102_0083 ME10	3600	3300	5500	≤19	0.94	110		
						PH731_0070K102_0083 ME20				≤24	2.8			
60.00	60/1	350	575	1150	3.5	PH731_0100K102_0060 ME10	3300	2800	5000	≤19	1.1	105		
						PH731_0100K102_0060 ME20				≤24	3.0			
64.74	1748/27	440	868	1545	4.0	PH731_0070K102_0092 ME10	3600	3300	5500	≤19	0.98	110		
						PH731_0070K102_0092 ME20				≤24	2.9			
66.44	598/9	350	575	1150	3.5	PH731_0100K102_0066 ME10	3600	3300	5500	≤19	1.1	105		
						PH731_0100K102_0066 ME20				≤24	2.9			
69.26	14,405/208	440	882	1720	4.0	PH731_0050K202_0140 ME10	3900	3500	5500	≤19	1.1	116		
						PH731_0050K202_0140 ME20	3700			≤32	4.6			
						PH731_0050K202_0140 ME30	3500			5000	≤38		9.9	
70.98	3549/50	440	840	1545	4.0	PH731_0070K102_0100 ME10	4000	3800	6000	≤19	0.86	110		
						PH731_0070K102_0100 ME20	3700			3700	≤24		2.8	
80.96	1862/23	440	869	1545	4.0	PH731_0070K102_0115 ME10	3600	3300	5500	≤19	0.88	110		
						PH731_0070K102_0115 ME20				≤24	2.8			
83.09	1911/23	350	575	1150	3.5	PH731_0100K102_0083 ME10	3600	3300	5500	≤19	0.93	105		
						PH731_0100K102_0083 ME20				≤24	2.8			
87.35	2795/32	440	882	1720	4.0	PH731_0050K202_0175 ME10	3900	3500	5500	≤19	1.0	117		
						PH731_0050K202_0175 ME20	3700			≤32	4.4			
						PH731_0050K202_0175 ME30	3500			5000	≤38		9.7	
88.33	3003/34	440	840	1545	4.0	PH731_0070K102_0125 ME10	4000	3800	6000	≤19	0.79	110		
						PH731_0070K102_0125 ME20	3700			3700	≤24		2.7	
92.49	17,480/189	350	575	1150	3.5	PH731_0100K102_0092 ME10	3600	3300	5500	≤19	0.97	105		
						PH731_0100K102_0092 ME20				≤24	2.9			
98.80	494/5	440	869	1545	4.0	PH731_0070K102_0140 ME10	4000	3800	6000	≤19	0.82	110		
						PH731_0070K102_0140 ME20	3700			3700	≤24		2.7	
115.7	2660/23	350	575	1150	3.5	PH731_0100K102_0115 ME10	3600	3300	5500	≤19	0.88	105		
						PH731_0100K102_0115 ME20				≤24	2.8			
115.9	14,835/128	440	882	1720	4.0	PH731_0050K202_0230 ME10	4000	3900	6500	≤19	0.87	117		
						PH731_0050K202_0230 ME20	3700			3700	6000		≤32	4.3
						PH731_0050K202_0230 ME30	3500			3500	5000		≤38	9.6
117.0	117/1	440	840	1545	4.0	PH731_0070K102_0165 ME10	4000	4000	7000	≤19	0.74	110		
						PH731_0070K102_0165 ME20	3700			3700	6000		≤24	2.6

¹⁾ Based on input speed of 1500 RPM. See page 240 for details on torque calculations.

²⁾ Maximum momentary torque for emergency stops or heavy shock load. (Admissible stops per life of gearhead = 1,000 stops maximum.)

* Motor shaft adapter code (shaft diameter max - mm): ME10 (19), ME20 (32), ME30 (38), ME40 (48), ME50 (60)

Selection Data



Reducer Ratio (i)		Output Torque			Back-lash $\Delta\phi_2$	Part Number* (Gearhead + Input)	Max. Input Speed RPM (n1)			Motor Shaft ³⁾ Max ϕ d_{MW}	Input Inertia J_1	Tors. Stiffness C_2
		Nom. ¹⁾ M_{2N}	Accel. M_{2acc}	Peak ²⁾ M_{2NOT}			Continuous		Cyclic			
Nom.	Exact	Nm	Nm	Nm	arcmin		EL 1,2	EL 3,4,5,6	All	mm	kgcm ²	Nm/arcmin

PH7K (continued from previous page)

122.9	2090/17	440	869	1545	4.0	PH731_0070K102_0175 ME10	4000	3800	6000	≤ 19	0.77	111
						PH731_0070K102_0175 ME20	3700	3700		≤ 24	2.7	
139.8	559/4	440	882	1720	4.0	PH731_0050K202_0280 ME10	4000	3900	6500	≤ 19	0.81	117
						PH731_0050K202_0280 ME20	3700	3700	6000	≤ 24	2.7	
141.1	2821/20	440	840	1545	4.0	PH731_0070K102_0200 ME10	4000	4000	7000	≤ 19	0.71	111
						PH731_0070K102_0200 ME20	3700	3700	6000	≤ 24	2.6	
162.9	1140/7	440	869	1545	4.0	PH731_0070K102_0230 ME10	4000	4000	7000	≤ 19	0.72	111
						PH731_0070K102_0230 ME20	3700	3700	6000	≤ 24	2.6	
172.8	9675/56	440	882	1720	4.0	PH731_0050K202_0350 ME10	4000	3900	6500	≤ 19	0.76	117
						PH731_0050K202_0350 ME20	3700	3700	6000	≤ 24	2.7	
176.5	8827/50	440	774	1401	4.0	PH731_0070K102_0250 ME10	4000	4000	7000	≤ 19	0.68	111
						PH731_0070K102_0250 ME20	3700	3700	6000	≤ 24	2.6	
196.3	589/3	440	869	1545	4.0	PH731_0070K102_0280 ME10	4000	4000	7000	≤ 19	0.70	111
						PH731_0070K102_0280 ME20	3700	3700	6000	≤ 24	2.6	
231.1	1849/8	440	882	1720	4.0	PH731_0050K202_0460 ME10	4000	3900	6500	≤ 19	0.71	117
						PH731_0050K202_0460 ME20	3700	3700	6000	≤ 24	2.6	
232.7	11,400/49	350	575	1150	3.5	PH731_0100K102_0230 ME10	4000	4000	7000	≤ 19	0.72	105
						PH731_0100K102_0230 ME20	3700	3700	6000	≤ 24	2.6	
235.9	4719/20	440	589	1064	4.0	PH731_0070K102_0340 ME10	4000	4000	7000	≤ 19	0.63	111
245.7	3686/15	440	869	1545	4.0	PH731_0070K102_0350 ME10	4000	4000	7000	≤ 19	0.68	111
						PH731_0070K102_0350 ME20	3700	3700	6000	≤ 24	2.6	
277.7	6665/24	440	882	1432	4.0	PH731_0050K202_0560 ME10	4000	3900	6500	≤ 19	0.66	117
280.5	5890/21	350	575	1150	3.5	PH731_0100K102_0280 ME10	4000	4000	7000	≤ 19	0.70	105
						PH731_0100K102_0280 ME20	3700	3700	6000	≤ 24	2.6	
282.1	2821/10	413	496	896	4.0	PH731_0070K102_0400 ME10	4000	4000	7000	≤ 19	0.62	111
328.4	2299/7	440	819	1482	4.0	PH731_0070K102_0470 ME10	4000	4000	7000	≤ 19	0.63	111
351.1	7372/21	350	575	1150	3.5	PH731_0100K102_0350 ME10	4000	4000	7000	≤ 19	0.68	105
						PH731_0100K102_0350 ME20	3700	3700	6000	≤ 24	2.6	
352.2	35,217/100	336	403	728	4.0	PH731_0070K102_0500 ME10	4000	4000	7000	≤ 19	0.62	111
392.7	1178/3	440	690	1248	4.0	PH731_0070K102_0560 ME10	4000	4000	7000	≤ 19	0.62	111
469.2	22,990/49	350	575	1150	3.5	PH731_0100K102_0470 ME10	4000	4000	7000	≤ 19	0.63	105
490.2	2451/5	440	561	1014	4.0	PH731_0070K102_0700 ME10	4000	4000	7000	≤ 19	0.62	111
561.0	11,780/21	350	575	1150	3.5	PH731_0100K102_0560 ME10	4000	4000	7000	≤ 19	0.62	105

PHK Series: RIGHT ANGLE – Flange Output

¹⁾ Based on input speed of 1500 RPM. See page 240 for details on torque calculations.

²⁾ Maximum momentary torque for emergency stops or heavy shock load. (Admissible stops per life of gearhead = 1,000 stops maximum.)

* Motor shaft adapter code (shaft diameter max - mm): ME10 (19), ME20 (32), ME30 (38), ME40 (48), ME50 (60)

PHK Series: RIGHT ANGLE – Flange Output

Reducer Ratio (i)		Output Torque			Back- lash $\Delta\phi_2$	Part Number* (Gearhead + Input)	Max. Input Speed RPM (n1)			Motor Shaft ³⁾ Max ϕ d_{MW}	Input Inertia J_1	Tors. Stiff- ness C_2
		Nom. ¹⁾ M_{2N}	Accel. M_{2acc}	Peak ²⁾ M_{2NOT}			Continuous		Cyclic			
Nom.	Exact	Nm	Nm	Nm	arcmin	EL 1,2	EL 3,4,5,6	All	mm	kgcm ²	Nm/ arcmin	

PH8K (continued next page)

16.00	16/1	782	894	1213	4.0	PH831_0040K302_0040 ME20	2700	2300	4000	≤ 32	11	180
			1174	2917		PH831_0040K302_0040 ME30				≤ 38	16	183
20.00	20/1	978	1117	1516	4.0	PH831_0050K302_0040 ME20	2700	2300	4000	≤ 32	10	239
			1467	3646		PH831_0050K302_0040 ME30				≤ 38	15	243
26.88	215/8	1079	1502	2037	4.0	PH831_0050K302_0054 ME20	2700	2300	4000	≤ 32	7.8	242
						PH831_0050K302_0054 ME30				≤ 38	13	243
28.00	28/1	782	1173	2122	3.5	PH831_0070K202_0040 ME20	3000	2600	4500	≤ 32	7.0	242
						PH831_0070K202_0040 ME30				≤ 38	12	243
30.00	30/1	1100	1676	2273	4.0	PH831_0050K302_0060 ME20	2700	2300	4000	≤ 32	8.0	242
			1679	3646		PH831_0050K302_0060 ME30				≤ 38	13	244
30.55	336/11	683	683	926	3.5	PH831_0070K202_0044 ME10	3000	2600	4500	≤ 19	3.2	235
						PH831_0070K202_0044 ME20				≤ 32	6.6	243
						PH831_0070K202_0044 ME30				≤ 38	12	244
36.24	14,749/407	852	1278	2746	3.5	PH831_0070K202_0052 ME20	3000	2600	4500	≤ 32	6.0	243
						PH831_0070K202_0052 ME30				≤ 38	11	244
36.96	2365/64	1100	1800	2800	4.0	PH831_0050K302_0074 ME20	2700	2300	4000	≤ 32	7.0	243
						PH831_0050K302_0074 ME30				≤ 38	12	244
40.00	40/1	850	1392	2784	3.5	PH831_0100K202_0040 ME20	3000	2600	4500	≤ 32	6.7	259
						PH831_0100K202_0040 ME30				≤ 38	12	
42.00	42/1	895	939	1273	3.5	PH831_0070K202_0060 ME10	3000	2600	4500	≤ 19	2.6	240
			1342	2917		PH831_0070K202_0060 ME20				≤ 32	6.0	244
						PH831_0070K202_0060 ME30				≤ 38	11	
46.34	5375/116	1100	1848	3511	4.0	PH831_0050K302_0093 ME20	3200	2800	4500	≤ 32	6.1	244
						PH831_0050K302_0093 ME30				≤ 38	11	
46.78	15,953/341	928	1045	1418	3.5	PH831_0070K202_0067 ME10	3500	3100	5000	≤ 19	1.9	241
			1391	2917		PH831_0070K202_0067 ME20				≤ 32	5.3	244
						PH831_0070K202_0067 ME30				≤ 38	11	245
49.83	14,749/296	947	1421	2917	3.5	PH831_0070K202_0071 ME20	3000	2600	4500	≤ 32	5.6	244
						PH831_0070K202_0071 ME30				≤ 38	11	245
51.77	21,070/407	850	1392	2784	3.5	PH831_0100K202_0052 ME20	3000	2600	4500	≤ 32	5.8	259
						PH831_0100K202_0052 ME30				≤ 38	11	260

¹⁾ Based on input speed of 1500 RPM. See page 240 for details on torque calculations.

²⁾ Maximum momentary torque for emergency stops or heavy shock load. (Admissible stops per life of gearhead = 1,000 stops maximum.)

* Motor shaft adapter code (shaft diameter max - mm): ME10 (19), ME20 (32), ME30 (38), ME40 (48), ME50 (60)

Selection Data



Reducer Ratio (i)		Output Torque			Backlash $\Delta\phi_2$	Part Number* (Gearhead + Input)	Max. Input Speed RPM (n1)			Motor Shaft ³⁾ Max ϕ d_{MW}	Input Inertia J_1	Tors. Stiffness C_2
		Nom. ¹⁾ M_{2N}	Accel. M_{2acc}	Peak ²⁾ M_{2NOT}			Continuous		Cyclic			
Nom.	Exact	Nm	Nm	Nm	arcmin		EL 1,2	EL 3,4,5,6	All	mm	kgcm ²	Nm/arcmin

PH8K (continued next page)

58.05	1161/20	1100	1297	1760	4.0	PH831_0050K302_0115 ME10	3200	2800	4500	≤19	2.1	242
			1848	3646		PH831_0050K302_0115 ME20				≤32	5.5	244
						PH831_0050K302_0115 ME30				≤38	11	245
58.78	17,458/297	1000	1314	1782	3.5	PH831_0070K202_0084 ME10	3500	3100	5000	≤19	1.5	242
			1478	2917		PH831_0070K202_0084 ME20				≤32	4.9	245
						PH831_0070K202_0084 ME30				≤38	10	
60.00	60/1	850	1341	1819	3.5	PH831_0100K202_0060 ME10	3000	2600	4500	≤19	2.4	257
			1392	2784		PH831_0100K202_0060 ME20				≤32	5.8	259
						PH831_0100K202_0060 ME30				≤38	11	260
64.33	15,953/248	1000	1438	1950	3.5	PH831_0070K202_0092 ME10	3500	3100	5000	≤19	1.7	243
			1478	2917		PH831_0070K202_0092 ME20				≤32	5.1	245
						PH831_0070K202_0092 ME30				≤38	10	
66.83	22,790/341	850		2026	3.5	PH831_0100K202_0067 ME10	3500	3100	5000	≤19	1.8	258
			1392	2784		PH831_0100K202_0067 ME20				≤32	5.2	260
						PH831_0100K202_0067 ME30				≤38	11	
69.68	7525/108	1100	1557	2112	4.0	PH831_0050K302_0140 ME10	3500	3100	5000	≤19	1.7	243
			1848	3646		PH831_0050K302_0140 ME20				≤32	5.1	244
						PH831_0050K302_0140 ME30				≤38	10	245
70.51	20,167/286	1000		2137	3.5	PH831_0070K202_0100 ME10	3900	3500	5500	≤19	1.3	243
			1478	2917		PH831_0070K202_0100 ME20	3700		5000	≤32	4.7	245
						PH831_0070K202_0100 ME30	3500			≤38	10	
80.82	8729/108	1000		2450	3.5	PH831_0070K202_0115 ME10	3500	3100	5000	≤19	1.4	244
			1478	2917		PH831_0070K202_0115 ME20				≤32	4.8	245
						PH831_0070K202_0115 ME30				≤38	10	
83.97	24,940/297	850		2545	3.5	PH831_0100K202_0084 ME10	3500	3100	5000	≤19	1.5	259
			1392	2784		PH831_0100K202_0084 ME20				≤32	4.9	260
						PH831_0100K202_0084 ME30				≤38	10	
86.47	7955/92	1100		2621	4.0	PH831_0050K302_0175 ME10	3500	3100	5000	≤19	1.4	244
			1848	3646		PH831_0050K302_0175 ME20				≤32	4.8	245
						PH831_0050K302_0175 ME30				≤38	10	
88.94	3913/44	1000		2696	3.5	PH831_0070K202_0125 ME10	3900	3500	5500	≤19	1.1	244
			1478	2917		PH831_0070K202_0125 ME20	3700		5000	≤32	4.5	245
						PH831_0070K202_0125 ME30	3500			≤38	9.8	

PHK Series: RIGHT ANGLE – Flange Output

¹⁾ Based on input speed of 1500 RPM. See page 240 for details on torque calculations.

²⁾ Maximum momentary torque for emergency stops or heavy shock load. (Admissible stops per life of gearhead = 1,000 stops maximum.)

* Motor shaft adapter code (shaft diameter max - mm): ME10 (19), ME20 (32), ME30 (38), ME40 (48), ME50 (60)

PHK Series: RIGHT ANGLE – Flange Output

Reducer Ratio (i)		Output Torque			Back-lash $\Delta\phi_2$	Part Number* (Gearhead + Input)	Max. Input Speed RPM (n1)			Motor Shaft ³⁾ Max ϕ d_{MW}	Input Inertia J_1	Tors. Stiffness C_2
		Nom. ¹⁾ M_{2N}	Accel. M_{2acc}	Peak ²⁾ M_{2NOT}			Continuous		Cyclic			
Nom.	Exact	Nm	Nm	Nm	arcmin	EL 1,2	EL 3,4,5,6	All	mm	kgcm ²	Nm/ arcmin	

PH8K (continued next page)

91.90	11395/124	850	1392	2784	3.5	PH831_0100K202_0092 ME10	3500	3100	5000	≤19	1.6	259
						PH831_0100K202_0092 ME20				≤32	5.0	260
						PH831_0100K202_0092 ME30				≤38	10	
96.96	20,167/208	1000	1478	2917	3.5	PH831_0070K202_0140 ME10	3900	3500	5500	≤19	1.2	244
						PH831_0070K202_0140 ME20	3700			≤32	4.6	245
						PH831_0070K202_0140 ME30	3500			5000	≤38	
115.5	6235/54	850	1392	2784	3.5	PH831_0100K202_0115 ME10	3500	3100	5000	≤19	1.3	259
						PH831_0100K202_0115 ME20				≤32	4.7	260
						PH831_0100K202_0115 ME30				≤38	10	
116.5	2795/24	1100	1848	3358	4.0	PH831_0050K302_0230 ME10	3800	3500	6000	≤19	1.1	244
				3646		PH831_0050K302_0230 ME20	3700			≤32	4.5	245
				PH831_0050K302_0230 ME30		3500	5000			≤38	9.9	
118.0	20,769/176	1000	1478	2917	3.5	PH831_0070K202_0170 ME10	4000	3900	6500	≤19	0.92	245
						PH831_0070K202_0170 ME20	3700	3700	6000	≤32	4.3	
						PH831_0070K202_0170 ME30	3500	3500	5000	≤38	9.6	
122.3	3913/32	1000	1478	2917	3.5	PH831_0070K202_0175 ME10	3900	3500	5500	≤19	1.0	245
						PH831_0070K202_0175 ME20	3700			≤32	4.4	
						PH831_0070K202_0175 ME30	3500			5000	≤38	
138.5	14,405/104	850	1392	2784	3.5	PH831_0100K202_0140 ME10	3900	3500	5500	≤19	1.2	260
						PH831_0100K202_0140 ME20	3700			≤32	4.6	
						PH831_0100K202_0140 ME30	3500			5000	≤38	
139.4	17,845/128	1100	1848	3646	4.0	PH831_0050K302_0280 ME10	3800	3500	6000	≤19	1.0	244
						PH831_0050K302_0280 ME20	3700			≤32	4.4	245
						PH831_0050K302_0280 ME30	3500			5000	≤38	
142.3	7826/55	1000	1478	2917	3.5	PH831_0070K202_0200 ME10	4000	3900	6500	≤19	0.85	245
						PH831_0070K202_0200 ME20	3700	3700	6000	≤24	2.7	
162.3	20,769/128	1000	1478	2917	3.5	PH831_0070K202_0230 ME10	4000	3900	6500	≤19	0.88	245
						PH831_0070K202_0230 ME20	3700	3700	6000	≤32	4.3	
						PH831_0070K202_0230 ME30	3500	3500	5000	≤38	9.6	
173.7	4515/26	1100	1848	3646	4.0	PH831_0050K302_0350 ME10	3800	3500	6000	≤19	0.90	245
						PH831_0050K302_0350 ME20	3700			≤24	2.8	

¹⁾ Based on input speed of 1500 RPM. See page 240 for details on torque calculations.

²⁾ Maximum momentary torque for emergency stops or heavy shock load. (Admissible stops per life of gearhead = 1,000 stops maximum.)

* Motor shaft adapter code (shaft diameter max - mm): ME10 (19), ME20 (32), ME30 (38), ME40 (48), ME50 (60)

Selection Data



Reducer Ratio (i)		Output Torque			Backlash $\Delta\phi_2$	Part Number* (Gearhead + Input)	Max. Input Speed RPM (n1)			Motor Shaft ³⁾ Max ϕ d_{MW}	Input Inertia J_1	Tors. Stiffness C_2
		Nom. ¹⁾ M_{2N}	Accel. M_{2acc}	Peak ²⁾ M_{2NOT}			Continuous		Cyclic			
Nom.	Exact	Nm	Nm	Nm	arcmin		EL 1,2	EL 3,4,5,6	All	mm	kgcm ²	Nm/arcmin

PH8K (continued from previous page)

174.7	2795/16	850	1392	2784	3.5	PH831_0100K202_0175 ME10	3900	3500	5500	≤19	1.0	260
						PH831_0100K202_0175 ME20	3700		≤32	4.4		
						PH831_0100K202_0175 ME30	3500		5000	≤38	9.7	
175.9	1935/11	1000	1478	2917	3.5	PH831_0070K202_0250 ME10	4000	3900	6500	≤19	0.78	245
						PH831_0070K202_0250 ME20	3700	3700	6000	≤24	2.7	
195.7	3913/20	1000	1478	2917	3.5	PH831_0070K202_0280 ME10	4000	3900	6500	≤19	0.82	245
						PH831_0070K202_0280 ME20	3700	3700	6000	≤24	2.7	
231.1	1849/8	1100	1848	3585	4.0	PH831_0050K302_0460 ME10	3800	3500	6000	≤19	0.80	245
						PH831_0050K302_0460 ME20	3700		≤24	2.7		
231.8	14,835/64	850	1392	2784	3.5	PH831_0100K202_0230 ME10	4000	3900	6500	≤19	0.87	260
						PH831_0100K202_0230 ME20	3700	3700	6000	≤32	4.3	
						PH831_0100K202_0230 ME30	3500	3500	5000	≤38	9.6	
235.3	12,943/55	1000	1242	2246	3.5	PH831_0070K202_0340 ME10	4000	3900	6500	≤19	0.72	245
						PH831_0070K202_0340 ME20	3700	3700	6000	≤24	2.6	
241.9	1935/8	1000	1478	2917	3.5	PH831_0070K202_0350 ME10	4000	3900	6500	≤19	0.76	245
						PH831_0070K202_0350 ME20	3700	3700	6000	≤24	2.7	
278.5	12,255/44	1100	1525	2757	4.0	PH831_0050K302_0560 ME10	3800	3500	6000	≤19	0.75	245
						PH831_0050K302_0560 ME20	3700		≤24	2.6		
279.5	559/2	850	1392	2784	3.5	PH831_0100K202_0280 ME10	4000	3900	6500	≤19	0.81	260
						PH831_0100K202_0280 ME20	3700	3700	6000	≤24	2.7	
282.8	9331/33	776	931	1458	3.5	PH831_0070K202_0400 ME10	4000	3900	6500	≤19	0.67	245
323.6	12,943/40	1000	1478	2917	3.5	PH831_0070K202_0460 ME10	4000	3900	6500	≤19	0.71	245
						PH831_0070K202_0460 ME20	3700	3700	6000	≤24	2.6	
345.5	9675/28	850	1392	2784	3.5	PH831_0100K202_0350 ME10	4000	3900	6500	≤19	0.76	260
						PH831_0100K202_0350 ME20	3700	3700	6000	≤24	2.7	
353.4	46,655/132	647	776	1404	3.5	PH831_0070K202_0500 ME10	4000	3900	6500	≤19	0.65	245
388.8	9331/24	1000	1281	2005	3.5	PH831_0070K202_0560 ME10	4000	3900	6500	≤19	0.66	245
462.3	1849/4	850	1392	2784	3.5	PH831_0100K202_0460 ME10	4000	3900	6500	≤19	0.71	260
						PH831_0100K202_0460 ME20	3700	3700	6000	≤24	2.6	
486.0	46,655/96	889	1067	1930	3.5	PH831_0070K202_0690 ME10	4000	3900	6500	≤19	0.64	245
555.4	6665/12	850	1392	2784	3.5	PH831_0100K202_0560 ME10	4000	3900	6500	≤19	0.66	260

PHK Series: RIGHT ANGLE – Flange Output

¹⁾ Based on input speed of 1500 RPM. See page 240 for details on torque calculations.

²⁾ Maximum momentary torque for emergency stops or heavy shock load. (Admissible stops per life of gearhead = 1,000 stops maximum.)

* Motor shaft adapter code (shaft diameter max - mm): ME10 (19), ME20 (32), ME30 (38), ME40 (48), ME50 (60)

PHK Series: RIGHT ANGLE – Flange Output

Reducer Ratio (i)		Output Torque			Back-lash $\Delta\phi_2$	Part Number* (Gearhead + Input)	Max. Input Speed RPM (n1)			Motor Shaft ³⁾ Max ϕ d _{MW}	Input Inertia J ₁	Tors. Stiffness C ₂
		Nom. ¹⁾ M _{2N}	Accel. M _{2acc}	Peak ²⁾ M _{2NOT}			Continuous		Cyclic			
Nom.	Exact	Nm	Nm	Nm	arcmin		EL 1,2	EL 3,4,5,6	All	mm	kgcm ²	Nm/ arcmin

PH9K (continued next page)

32.54	17,081/525	2758	3840	6480	4.5	PH931_0040K513_0081 ME30	1900	1800	3200	≤38	25	521
						PH931_0040K513_0081 ME40				≤48	47	520
40.60	203/5	2884	3840	7500	4.5	PH931_0040K513_0100 ME30	1900	1800	3200	≤38	21	522
						PH931_0040K513_0100 ME40				≤48	43	
48.80	17,081/350	3000	4500	9000	4.0	PH931_0060K513_0081 ME30	1900	1800	3200	≤38	24	727
						PH931_0060K513_0081 ME40				≤48	46	726
60.90	609/10	3000	4500	9000	4.0	PH931_0060K513_0100 ME30	1900	1800	3200	≤38	20	728
						PH931_0060K513_0100 ME40				≤48	42	
76.85	1537/20	3000	4500	9000	4.0	PH931_0060K513_0130 ME30	2300	2200	3600	≤38	17	729
						PH931_0060K513_0130 ME40				≤48	39	728
96.56	26,071/270	3000	4500	7212	4.0	PH931_0060K513_0160 ME20	2300	2200	3600	≤32	9.4	728
				9000		PH931_0060K513_0160 ME30				≤38	15	729
						PH931_0060K513_0160 ME40				≤48	37	
116.1	27,869/240	3000	4500	8673	4.0	PH931_0060K513_0195 ME20	2800	2500	4200	≤32	8.2	728
				9000		PH931_0060K513_0195 ME30				≤38	14	729
						PH931_0060K513_0195 ME40				≤48	36	
146.1	11,687/80	3000	4500	9000	4.0	PH931_0060K513_0240 ME20	2800	2500	4200	≤32	7.0	729
						PH931_0060K513_0240 ME30				≤38	12	730
						PH931_0060K513_0240 ME40				≤48	34	
193.8	62,031/320	3000	4500	9000	4.0	PH931_0060K513_0320 ME20	3400	3000	5000	≤32	6.0	729
						PH931_0060K513_0320 ME30				≤38	11	730
						PH931_0060K513_0320 ME40	3000		4500	≤48	33	
231.2	8091/35	3000	4500	9000	4.0	PH931_0060K513_0390 ME20	3400	3000	5000	≤32	5.5	730
						PH931_0060K513_0390 ME30				≤38	11	
289.0	8091/28	3000	4500	9000	4.0	PH931_0060K513_0480 ME20	3400	3000	5000	≤32	5.0	730
						PH931_0060K513_0480 ME30				≤38	10	
387.3	25,172/65	3000	4500	9000	4.0	PH931_0060K513_0650 ME20	3400	3000	5000	≤32	4.7	730
						PH931_0060K513_0650 ME30				≤38	10	
465.6	26,071/56	3000	4500	8835	4.0	PH931_0060K513_0780 ME20	3400	3000	5000	≤24	3.0	730

¹⁾ Based on input speed of 1500 RPM. See page 240 for details on torque calculations.

²⁾ Maximum momentary torque for emergency stops or heavy shock load. (Admissible stops per life of gearhead = 1,000 stops maximum.)

* Motor shaft adapter code (shaft diameter max - mm): ME10 (19), ME20 (32), ME30 (38), ME40 (48), ME50 (60)

Selection Data



Nom.	Reducer Ratio (i) Exact	Output Torque			Backlash $\Delta\phi_2$ arcmin	Part Number* (Gearhead + Input)	Max. Input Speed RPM (n1)			Motor Shaft ³⁾ Max ϕ d_{MW} mm	Input Inertia J_1 kgcm ²	Tors. Stiffness C_2 Nm/arcmin
		Nom. ¹⁾ M_{2N} Nm	Accel. M_{2acc} Nm	Peak ²⁾ M_{2NOT} Nm			Continuous		Cyclic			
		EL 1,2	EL 3,4,5,6	All								

PH10K (continued next page)

48.64	255,285/5248	5000	7143	9688	4.0	PH1031_0060K613_0081 ME30	1800	1700	3000	≤38	37	1201
			7500	15,000		PH1031_0060K613_0081 ME40				≤48	60	1202
						PH1031_0060K613_0081 ME50				≤60	88	1205
75.77	9699/128	5000	7500	15,000	4.0	PH1031_0060K613_0125 ME30	2200	2000	3500	≤38	24	1206
						PH1031_0060K613_0125 ME40				≤48	46	
						PH1031_0060K613_0125 ME50				≤60	75	1207
95.21	54,839/576	5000	7500	15,000	4.0	PH1031_0060K613_0160 ME30	2200	2000	3500	≤38	20	1207
						PH1031_0060K613_0160 ME40				≤48	42	
						PH1031_0060K613_0160 ME50				≤60	71	1208
114.0	51,057/448	5000	6275	8512	4.0	PH1031_0060K613_0190 ME20	2600	2300	4000	≤32	12	1205
						PH1031_0060K613_0190 ME30				≤38	17	
			7500	15,000		PH1031_0060K613_0190 ME40				≤48	39	1208
						PH1031_0060K613_0190 ME50				≤60	68	
144.0	73,749/512	5000	7500	15,000	4.0	PH1031_0060K613_0240 ME30	2600	2300	4000	≤38	15	1209
						PH1031_0060K613_0240 ME40				≤48	37	
						PH1031_0060K613_0240 ME50				≤60	66	
191.1	391,437/2048	5000	7500	12,523	4.0	PH1031_0060K613_0320 ME20	3100	2800	4500	≤32	7.7	1208
						PH1031_0060K613_0320 ME30				≤38	13	
				15,000		PH1031_0060K613_0320 ME40				≤48	35	1209
						PH1031_0060K613_0320 ME50				≤60	64	
229.9	470,859/2048	5000	7500	13,592	4.0	PH1031_0060K613_0380 ME20	3100	2800	4500	≤32	6.7	1209
						PH1031_0060K613_0380 ME30				≤38	12	
				15,000		PH1031_0060K613_0380 ME40				≤48	34	
						PH1031_0060K613_0380 ME50				≤60	63	
286.4	119,133/416	5000	7500	14,340	4.0	PH1031_0060K613_0480 ME20	3100	2800	4500	≤32	5.9	1209
						PH1031_0060K613_0480 ME30				≤38	11	
382.3	391,437/1024	5000	7500	15,000	4.0	PH1031_0060K613_0640 ME20	3100	2800	4500	≤32	5.2	1209
						PH1031_0060K613_0640 ME30				≤38	10	1210
456.8	380,091/832	5000	7500	15,000	4.0	PH1031_0060K613_0760 ME20	3100	2800	4500	≤32	4.9	1210
						PH1031_0060K613_0760 ME30				≤38	10	

PHK Series: RIGHT ANGLE – Flange Output

¹⁾ Based on input speed of 1500 RPM. See page 240 for details on torque calculations.

²⁾ Maximum momentary torque for emergency stops or heavy shock load. (Admissible stops per life of gearhead = 1,000 stops maximum.)

* Motor shaft adapter code (shaft diameter max - mm): ME10 (19), ME20 (32), ME30 (38), ME40 (48), ME50 (60)