

PH Series: INLINE — Flange Output

PH Features

- 4:1 to 121:1 ratios (higher ratios available. Contact STÖBER.)
- Quiet running (As low as 55dB(A))
- High load capacity and tilting rigidity through symmetrical bearing arrangement
- FKM seals for extended gearbox life
- Large motor input option to accept bigger diameter motor shafts so you don't use an oversized gearbox
- Error free motor mounting and quick changeover with toleranced pilot on motor plate
- Low no load running torque, giving you more torque for your application
- Magnetic oil filtration to remove contaminants to prevent breakdowns
- Build and ship in one day
- Assembled in the USA

STÖBER PH Series Servo Precision Planetary Gearheads are designed for applications that demand torsional stiffness and tilting rigidity. The advanced lines can handle high accuracy machines. Every gearbox is made to order. STÖBER will custom whatever you need to fit your application. Contact us today to learn more.

**All PH Series and
select PHV Series
SHIP in 1 DAY!**

**NO EXPEDITE FEE FOR 24
HOUR SERVICE**

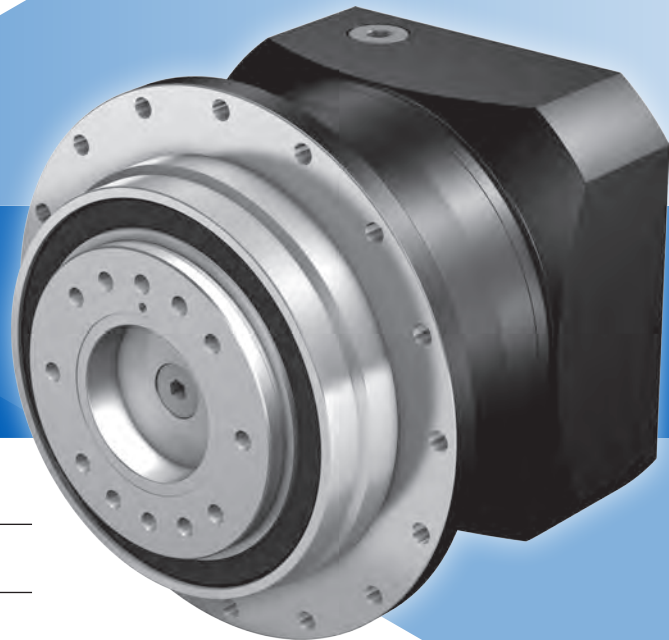

General Specifications

Ambient Temperature	0°C to +40°C (104°F) [Unit temperature <90°C Max]
Backlash	≤1 arcmins (see performance overview page 30)
Coating	Black (RAL-9005)
Degree of Protection	IP65
Direction of Rotation	Input and output rotate the SAME direction
Efficiency	1 stage 96%; 2 stage 93%; 3 stage 90%
Input RPM	Up to 8,000 RPM
Installation	Requires 12.9 fasteners. See page 306 for more information
Lubrication	Lubricated for life – standard Mobil SHC629; option food grade Mobil SHC CIBUS 150
Mounting Position	Unrestricted, see page 31
Warranty	5 Year Limited (2 Years on normal wear items: bearings, seals, etc.)



Overview

Selection Options At-a-Glance

Using the **Selection Data** table later in this section, select the PH Series Gearhead with the appropriate performance and design options tailored to your motor choice and exact application requirements. Use the part number guide below as a reference to build a part number for the complete gearhead assembly.

Part Number Examples:

1	2	3	4	5	6	7	8	9	0	!
PH	3	3	1	S	F	S	S	0040	ME	L
PHV	9	3	3		F			0910	ME	L

Design Option	Part Number Code	Description
1 Series	PH PHV	Rotating flange output planetary Rotating flange output planetary — 3 Stage (size 9-10 only)
2 Size	3 4 5 7 8 9 10	7 sizes of gearhead
3 Generation	3	Version of gearhead
4 # of Stages	1 2 3	One stage for ratios of ≤ 10:1 Two stage for ratios >10:1 Three stage (PHV: Size 9-10)
5 Housing	S	Standard (PH3-8 only)
6 Output	F	Flange output
7 Bearing	S V	Standard (PH3-8 only) Reinforced Bearing (PH3-PH5)
8 Backlash	S R	Standard Backlash (PH3-8 only) Reduced backlash (PH3-8 only)
9 Ratio	0040	Ratios range from 4:1 to 100:1 (0040=4:1; 0160=16:1; 1000=100:1, etc.)
0 Motor Adapter	ME MF MB	Motor Adapter with EasyAdapt coupling Motor Adapter with FlexiAdapt coupling (PH3-8)(Contact factory for this option) ServoStop motor adapter with brake (Contact factory for this option)
! Options	L	Large Input

Options

ME Adapter Option

- MSS1 Seal – special input seal for longer life (For sizes PH5-8). Contact factory for this option.

Integrated Safety Brake

- ServoStop – provides dynamic braking during power failures or emergency stops in hazardous situations. Contact factory for this option.

Coating Option

- Available with multi-layer, industrial 316 stainless steel epoxy coating. Contact factory for this option.

Large Input

- Accommodates a larger diameter motor shaft without going to a larger size gearbox.

ATEX

- ATMosphere EXplosible – rated for explosive environments. Contact factory for this option and allow additional time for delivery.

Rack and Pinion Systems

- PH available with rack and pinion. Contact factory for this option.



PH Series: INLINE — Flange Output

PH Performance Overview

PH Series performance is dependent on several factors including duty cycle, bearing design, gearhead size and stage configuration, among others. Use the chart below for preliminary evaluation, then use the following performance chart and selection information on the following pages for specific performance sizing and selection.

		Size 3		Size 4		Size 5	
		# of Stages		# of Stages		# of Stages	
		1	2	1	2	1	2
Acceleration Torque M_{2BMAX}	Nm	80		189		385	
Output Torque Nom. ¹ M_{2N}	Nm	45		120		296	
Torsional Stiffness C_2	Nm/arcmin	15		36		91	
Torsional Backlash ²⁾ $\Delta\phi$ $\Delta\phi$ Reduced	arcmin	≤ 4 ≤ 2		≤ 3 ≤ 1		≤ 3 ≤ 1	
Input Speed Max. n_{1MAX}	Continuous Cyclic	5500 8000	6000 8000	3500 7000	4500 8000	3300 6500	4000 8000
Efficiency (@nom torque)	%	96	94	96	94	96	94
Weight	kg lbs	2.2 4.8	2.4 5.28	4.8 10.6	5.2 11.4	7.7 16.9	8.8 19.4
Noise ³⁾	dB(A)	≤ 55		≤ 56		≤ 57	

Performance by Bearing Design Option ⁴⁾

Permitted Axial Force F_{2ax100}	N	1650		2150		4150	
Permitted Tilting Torque M_{2K100}	Nm	101		296		475	
Tilting Stiffness C_{2K}	Nm/arcmin	75		192		429	

Performance by Reinforced Bearing Design Option – Choose V Option ⁴⁾

Permitted Axial Force F_{2ax100}	N	2200		2900		5500	
Permitted Tilting Torque ≤ 100RPM M_{2K100}	Nm	150		354		572	
Tilting Stiffness C_{2K}	Nm/arcmin	80		217		478	

¹⁾ Ratings based on input speed (n_1) of 1500 RPM.

For torque at higher input speeds (M_{2NX}) solve the formula:
where n_1 = Actual Input Speed.

$$M_{2NX} = \frac{M_{2N}}{\sqrt[3]{\frac{n_1}{1500}}}$$

²⁾ Tested at 1.5% of nominal torque and recorded on the output side of the gearhead. For lower backlash, contact STÖBER technical support.

³⁾ Measurement at one (1) meter distance with input speed (n_1) of 1500 RPM.

⁴⁾ Rating based on output speed (n_2) of 100 RPM. For values at other speeds see page 33.

Backlash Options In Stock

All standard backlash options are in stock and ship in one day. These reduced backlash options are in stock and ship in one day.

	PH331	PH431	PH432	PH531
Ratio	0070	0100	0250 1000	0050 0100

Overview



Note: Overview data is general. Actual data is dependent on case size and ratio

PH Series: INLINE — Flange Output

7		8		9		10	
1	2	1	2	2	3	2	3
882		2100		5000		7500	
600		1557		3000		5000	
207		561		1201		1743	
≤3 ≤1		≤3 ≤1		≤3 -		≤3 -	
2500 5000	3700 7000	2200 4000	3000 6000	2800 4500	2500 4500	2800 4500	2500 4500
96	94	96	94	96	94	94	92
15.9 35		35.9 79	39.7 87.3	75.2 166	66.6 147	90.6 200	90 198
≤58		≤59		≤59		≤59	
6150		10,050		33,000		50,000	
1466		3486		7500		8800	
500		1550		7500		9500	
-		-		-		-	
-		-		-		-	
-		-		-		-	

PH Series Three-Stage Mounting Position

For all three stage units, the amount of lubrication depends on the mounting position.

When ordering any of these three stage units, the mounting position (EL1, EL5 or EL6) MUST BE SPECIFIED WITH THE ORDER!

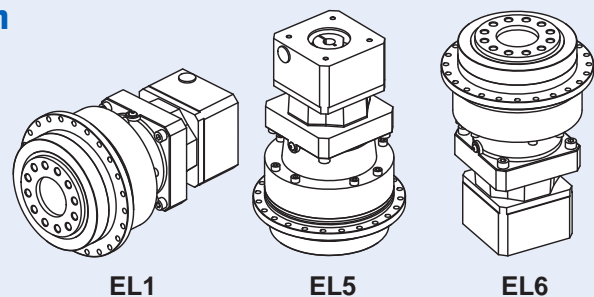

PH Series: INLINE — Flange Output

PH Series Motor Mounting Plate Option

(Motor information required with Motor Adapter ME option)

STOBER Servo Gearheads fit the motor of your choice with the appropriate motor mounting plate assembled between the motor and the gearhead.

NOTE: When ordering a gearhead:

- Specify the motor manufacturer and part number
- Provide the motor drawing with dimensions, or specify the motor mounting dimensions (per the list shown at right)

For a precise dimension on a specific motor, or for general assistance, we recommend you contact STOBER Technical Support.

Customer Required Dimensions for Properly Sized Motor Mounting Plate

- d2 Motor Shaft Diameter
(If an adapter bushing is required it will be supplied with the motor plate.)
- b6 Pilot Diameter
- e6 Bolt Circle Diameter
- s6 Bolt Diameter
- l5 Motor Shaft Length
- f6 Pilot Length
- a6 Square Flange
(Optional – motor plate will typically be made to match this dimension.)

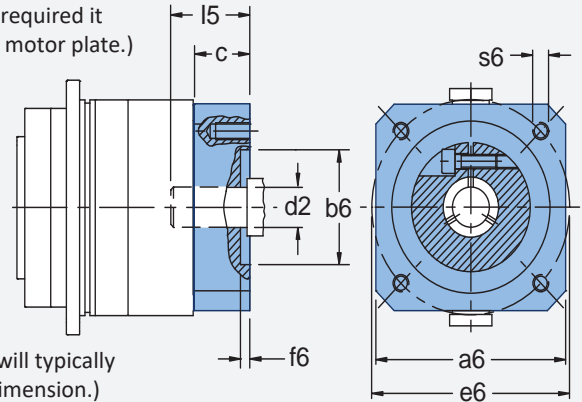

Motor Mounting Plate Dimensions — mm (Part Number Specific)

d2 Max. Motor Shaft Ø	c Min. Motor Plate Thickness *		Series / Size / # of Stages															
			3		4		5		7			8			9		10	
			1	2	1	2	1	2	1	2	3	1	2	3	2	3	2	3
14	15	PH		322														
19	18	PH	321	322...L		422												
24	21	PH	321...L		421	422...L		522										
32	24	PH			421...L		521	522...L		722								
38	25	PH					521...L		721	722...L			822					
		PHV														933		
48	33	PH										821			932		1032	

* Note that the c motor plate thickness is determined by the motor shaft length. The minimum motor plate thickness is the value listed.



Overview

PH No Load Running Torque*

Unit		Input Ratio T_R												
		One Stage				Two Stage								
		4	5	7	10	16	20	25	28	35	40	50	70	100
PH3	Nm	–	0.26	.016	.016	–	0.18	0.13	0.13	0.13	0.13	0.13	0.13	0.13
PH4	Nm	0.33	0.33	0.23	0.18	0.16	0.16	0.16	0.16	0.16	0.16	0.16	0.16	0.16
PH5	Nm	0.70	0.60	0.40	0.30	0.33	0.28	0.23	0.23	0.23	0.23	0.23	0.23	0.23
PH7	Nm	1.43	1.13	0.83	0.63	0.50	0.40	0.40	0.30	.030	0.30	0.30	0.30	0.30
PH8	Nm	2.25	1.85	1.35	0.95	0.73	0.73	0.63	0.53	0.53	0.53	0.53	0.53	0.53

* Torque is measured with the input at 2000 RPM and an ambient temperature of 20° C.

PH Series Permissible Motor Tilting Torque

The permissible tilting torque of the motor attached to the gear unit is a result of the static and dynamic load "F" from the motor weight, mass acceleration, and vibration multiplied by the distance from the center of gravity "I_s" of the motor.

M_{1K}	PH332_ME	PH331_ME PH432_ME	PH431_ME PH532_ME	PH531_ME PH732_ME	PH731_ME PH832_ME PHV933_ME	PH831_ME PH932_ME PH1032_ME PHV1033_ME
Nm	10	20	40	80	200	400

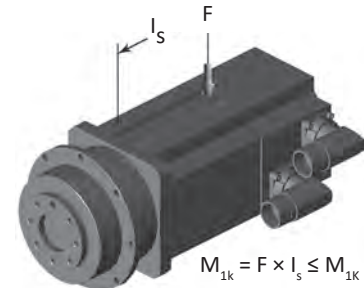

PH Series: INLINE — Flange Output

PH Series Permissible Output Shaft Load and Tilting Moments – Standard Bearings

Size	Z_2 Distance of Shaft Shoulder to Center of Output Bearing mm	F_{2ax100} Permitted Axial Force N	$F_{2rad100}$ Permitted Radial Force ≤100RPM N	$F_{2rad,acc}$ Radial Acceleration Force N	M_{2K100} Permitted Tilting Torque ≤100RPM Nm	$M_{2K,acc}$ Permitted Acceleration Tilting Torque Nm	C_{2K} Tilting Stiffness Nm/arcmin
3	62.5	1650	1613	1613	101	101	75
4	83.0	2150	3095	3571	257	296	192
5	97.0	4150	4536	4897	440	475	429
7	86.0	6150	17,045	17,045	1466	1466	500
8	125.5	10,050	27,778	27,778	3486	3486	1550
9	155.0	33,000	48,387	70,968	7500	11,000	7500
10	171.0	50,000	51,462	73,099	8800	12,500	9500

PH Series Permissible Output Shaft Load and Tilting Moments – Reinforced Bearings

Size	Z_2 Distance of Shaft Shoulder to Center of Output Bearing mm	F_{2ax100} Permitted Axial Force N	$F_{2rad100}$ Permitted Radial Force ≤100RPM N	$F_{2rad,acc}$ Radial Acceleration Force N	M_{2K100} Permitted Tilting Torque ≤100RPM Nm	$M_{2K,acc}$ Permitted Acceleration Tilting Torque Nm	C_{2K} Tilting Stiffness Nm/arcmin
3	66.5	2200	2250	2250	150	150	80
4	88.5	2900	4000	4000	354	354	217
5	104.0	5000	5500	5500	572	572	478

PH Series Load/Life/Speed Calculations

The permissible load and tilting moment values are based on an output speed of 100 RPM. For higher speeds the following applies, where n_2 is the desired speed:

$$F_{2radN} = \frac{F_{2rad100}}{\sqrt[3]{\frac{n_2}{100rpm}}} \quad F_{2ax} = \frac{F_{2ax100}}{\sqrt[3]{\frac{n_2}{100}}} \quad M_{2kX} = \frac{M_{2k100}}{\sqrt[3]{\frac{n_2}{100}}}$$

The application output tilting moment should be determined by the following formula:

$$M_{2k,acc*} = \frac{2 \cdot F_{2ax100*} \cdot y_2 + F_{2rad,acc*} \cdot (x_2 + z_2)}{1000} \leq M_{2k,acc}$$

$$M_{2k,eq*} = \sqrt[3]{\frac{n_{2b1} \cdot t_{b1} \cdot M_{2kb1}^3 + \dots + n_{2bn} \cdot t_{bn} \cdot M_{2kbn}^3}{n_{2b1} \cdot t_{b1} + \dots + n_{2bn} \cdot t_{bn}}} \leq M_{2kN}$$

$$F_{2rad,eq*} = \sqrt[3]{\frac{n_{2b1} \cdot t_{b1} \cdot F_{2rb1}^3 + \dots + n_{2bn} \cdot t_{bn} \cdot F_{2rbn}^3}{n_{2b1} \cdot t_{b1} + \dots + n_{2bn} \cdot t_{bn}}} \leq F_{2radN}$$

Where:

- Z₂** Distance of Shaft Shoulder to Center of Output Bearing
- n₂** Actual Average Output Speed
- X₂** Distance of the Shaft Shoulder to the Force Application Point
- Y₂** Distance of the Shaft Axis to the Axial Force Application Point
- F_{2ax}*** Actual Axial Force at Gear Unit Output
- F_{2ax100}** Permitted Axial Force
- F_{2rad100}** Permitted Radial Force ≤100RPM
- F_{2rad,acc}** Radial Acceleration Force
- F_{2rad,acc*}** Radial Acceleration Force at Gear Unit Output
- M_{2K100}** Permitted Tilting Torque ≤100RPM
- M_{2K,acc}** Permitted Acceleration Tilting Torque
- M_{2k,acc*}** Permitted Acceleration Tilting Torque at Gear Unit Output
- C_{2K}** Tilting Stiffness

All formulas shown are based on METRIC values

Upper case letters are permissible values. Lower case letters are for existing values.

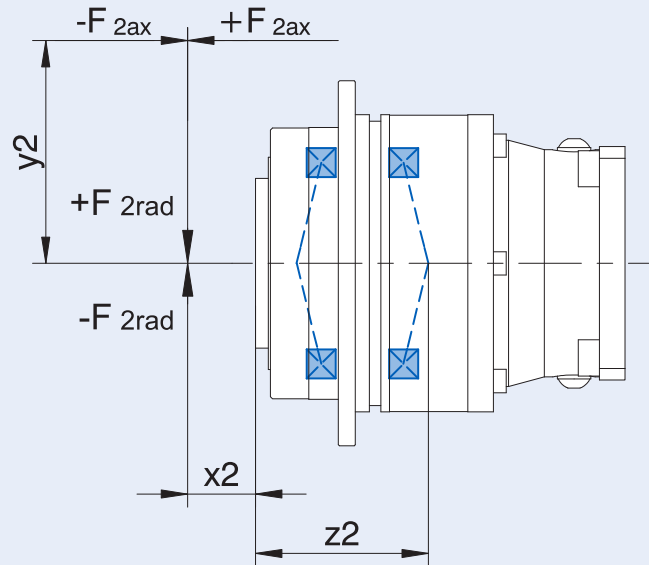

The hours of life (L_h) of the unit can be determined by the following formula:

bearing life for duty cycle ≤ 40%

$$L_h > 10,000 \text{ hours if } M_{2k100}/M_{2A*} < 1.25 \text{ and } > 1$$

$$L_h > 20,000 \text{ hours if } M_{2k100}/M_{2A*} > 1.25 \text{ and } > 1.5$$

$$L_h > 30,000 \text{ hours if } M_{2k100}/M_{2A*} < 1.5$$

bearing life for duty cycle ≥ 40%

$$L_{hA} = L_h \left(\frac{40\%}{\text{Duty Cycle}} \right)$$



Selection Data

Exact Ratio (i)	Output Torque						Part Number* (Gearhead + Input)	Max. Input Speed RPM (n1)		Motor Shaft ³⁾ Max Ø d _{MW} mm	Input Inertia J ₁ kgcm ²	Tors. Stiffness C ₂ Nm/arcmin	Oper. Noise L _{PA} dB(A)
	Nom. ¹⁾ M _{2N}	Accel. M _{2acc}	Accel. Torque for Reduced Backlash M _{2accHT}	Peak ²⁾ M _{2NOT}	Backlash Δφ ₂ arcmin	Red. Backlash Δφ _{2red} arcmin		Cont.	Cyclic				
	Nm	Nm	Nm	Nm	arcmin	arcmin							

PH3

5.000	45	80	85	160	4	2	PH331_0050 ME	4000	8000	≤19	0.46	15	58
							PH331_0050 MEL			≤24	0.89		
7.000	45	75	78	150	4	2	PH331_0070 ME	5000	8000	≤19	0.42	12	57
							PH331_0070 MEL			≤24	0.85		
10.00	36	60	60	120	4	2	PH331_0100 ME	5500	8000	≤19	0.40	9.1	55
							PH331_0100 MEL			≤24	0.83		
20.00	45	80	85	160	4	2	PH332_0200 ME	5500	8000	≤14	0.14	14	59
							PH332_0200 MEL			≤19	0.42		
25.00	50	80	85	160	4	2	PH332_0250 ME	6000	8000	≤14	0.12	14	57
							PH332_0250 MEL			≤19	0.41		
28.00	50	75	75	150	4	2	PH332_0280 ME	6000	8000	≤14	0.14	12	59
							PH332_0280 MEL			≤19	0.42		
35.00	50	80	85	160	4	2	PH332_0350 ME	6000	8000	≤14	0.12	14	56
							PH332_0350 MEL			≤19	0.41		
40.00	50	67	67	134	4	2	PH332_0400 ME	6000	8000	≤14	0.14	9.0	59
							PH332_0400 MEL			≤19	0.42		
50.00	50	75	75	150	4	2	PH332_0500 ME	6000	8000	≤14	0.12	12	54
							PH332_0500 MEL			≤19	0.41		
70.00	53	69	69	138	4	2	PH332_0700 ME	6000	8000	≤14	0.10	11	54
							PH332_0700 MEL			≤19	0.40		
100.0	46	60	60	120	4	2	PH332_1000 ME	6000	8000	≤14	0.10	8.9	54
							PH332_1000 MEL			≤19	0.39		

PH Series: INLINE — Flange Output

¹⁾ Based on input speed of 1500 RPM. See page 34 for details on torque calculations.

²⁾ Maximum momentary torque for emergency stops or heavy shock load. (Admissible stops per life of gearhead = 1,000 stops maximum.)

³⁾ For additional motor shaft sizes or smaller inertia value, please visit configurator.stober.com

* ME= Motor Adapter L=Large Input Option

PH Series: INLINE – Flange Output

Exact Ratio (i)	Output Torque				Backlash $\Delta\phi_2$	Red. Backlash $\Delta\phi_{2red}$	Part Number* (Gearhead + Input)	Max. Input Speed RPM (n1)		Motor Shaft ³⁾ Max ϕ d_{MW}	Input Inertia J_1	Tors. Stiffness C_2	Oper. Noise L_{PA}
	Nom. ¹⁾ M_{2N}	Accel. M_{2acc}	Accel. Torque for Reduced Backlash M_{2accHT}	Peak ²⁾ M_{2NOT}				Cont.	Cyclic				
	Nm	Nm	Nm	Nm				arcmin	arcmin				

PH4

4.000	90	136	189	273	3	1	PH431_0040 ME	2600	5000	≤ 24	1.3	36	61
							PH431_0040 MEL			≤ 32	2.9		
5.000	90	172	189	344	3	1	PH431_0050 ME	3000	6000	≤ 24	1.1	35	59
							PH431_0050 MEL			≤ 32	2.7		
7.000	90	160	175	320	3	1	PH431_0070 ME	3200	6000	≤ 24	0.99	30	58
							PH431_0070 MEL			≤ 32	2.6		
10.00	75	115	115	230	3	1	PH431_0100 ME	3500	7000	≤ 24	0.91	21	56
							PH431_0100 MEL			≤ 32	2.5		
16.00	90	160	173	312	3	1	PH432_0160 ME	4000	8000	≤ 19	0.52	31	60
							PH432_0160 MEL			≤ 24	0.95		
20.00	95	150	150	299	3	1	PH432_0200 ME	4000	8000	≤ 19	0.47	31	60
							PH432_0200 MEL			≤ 24	0.90		
25.00	100	161	174	322	3	1	PH432_0250 ME	4500	8000	≤ 19	0.47	32	58
							PH432_0250 MEL			≤ 24	0.90		
28.00	95	160	173	312	3	1	PH432_0280 ME	4500	8000	≤ 19	0.50	31	57
							PH432_0280 MEL			≤ 24	0.93		
35.00	110	160	174	320	3	1	PH432_0350 ME	4500	8000	≤ 19	0.46	32	57
							PH432_0350 MEL			≤ 24	0.89		
40.00	110	155	169	310	3	1	PH432_0400 ME	4500	8000	≤ 19	0.50	30	55
							PH432_0400 MEL			≤ 24	0.92		
50.00	120	159	174	318	3	1	PH432_0500 ME	4500	8000	≤ 19	0.46	31	55
							PH432_0500 MEL			≤ 24	0.89		
70.00	120	158	164	316	3	1	PH432_0700 ME	4500	8000	≤ 19	0.42	27	55
							PH432_0700 MEL			≤ 24	0.85		
100.0	85	110	110	220	3	1	PH432_1000 ME	4500	8000	≤ 19	0.40	20	55
							PH432_1000 MEL			≤ 24	0.83		

¹⁾ Based on input speed of 1500 RPM. See page 34 for details on torque calculations.

²⁾ Maximum momentary torque for emergency stops or heavy shock load. (Admissible stops per life of gearhead = 1,000 stops maximum.)

³⁾ For additional motor shaft sizes or smaller inertia value, please visit configurator.stober.com

* ME= Motor Adapter L=Large Input Option



Exact Ratio (i)	Output Torque						Part Number* (Gearhead + Input)	Max. Input Speed RPM (n1)		Motor Shaft ³⁾ Max Ø d _{MW}	Input Inertia J ₁	Tors. Stiffness C ₂	Oper. Noise L _{PA}
	Nom. ¹⁾ M _{2N}	Accel. M _{2acc}	Accel. Torque for Reduced Backlash M _{2accHT}	Peak ²⁾ M _{2NOT}	Backlash Δφ ₂	Red. Backlash Δφ _{2red}							
	Nm	Nm	Nm	Nm	arcmin	arcmin		Cont.	Cyclic	mm	kgcm ²	Nm/arcmin	dB(A)

PH5

4.000	210	355	387	696	3	1	PH531_0040 ME	2200	5000	≤32	4.1	90	62
							PH531_0040 MEL			≤38	7.7	91	
5.000	220	385	400	705	3	1	PH531_0050 ME	2500	5500	≤32	3.5	91	60
							PH531_0050 MEL			≤38	7.1	91	
7.000	210	370	387	705	3	1	PH531_0070 ME	3000	6000	≤32	3.1	75	59
							PH531_0070 MEL			≤38	6.6	75	
10.00	180	288	288	575	3	1	PH531_0100 ME	3300	6500	≤32	2.8	53	57
							PH531_0100 MEL			≤38	6.3	53	
16.00	230	355	355	696	3	1	PH532_0160 ME	3500	7000	≤24	1.2	82	61
							PH532_0160 MEL			≤32	2.8	82	
20.00	250	370	387	705	3	1	PH532_0200 ME	3500	7000	≤24	1.1	85	61
							PH532_0200 MEL			≤32	2.7	85	
25.00	260	385	400	705	3	1	PH532_0250 ME	3700	7500	≤24	1.0	84	59
							PH532_0250 MEL			≤32	2.7	84	
28.00	240	355	387	696	3	1	PH532_0280 ME	4000	8000	≤24	1.1	79	58
							PH532_0280 MEL			≤32	2.7	80	
35.00	290	385	400	705	3	1	PH532_0350 ME	4000	8000	≤24	1.0	84	58
							PH532_0350 MEL			≤32	2.6	84	
40.00	260	355	356	696	3	1	PH532_0400 ME	4000	8000	≤24	1.1	74	56
							PH532_0400 MEL			≤32	2.7	74	
50.00	296	385	400	705	3	1	PH532_0500 ME	4000	8000	≤24	1.0	79	56
							PH532_0500 MEL			≤32	2.6	79	
70.00	284	370	387	705	3	1	PH532_0700 ME	4000	8000	≤24	0.93	70	56
							PH532_0700 MEL			≤32	2.5	70	
100.0	221	288	288	575	3	1	PH532_1000 ME	4000	8000	≤24	0.88	52	56
							PH532_1000 MEL			≤32	2.5	52	

¹⁾ Based on input speed of 1500 RPM. See page 34 for details on torque calculations.

²⁾ Maximum momentary torque for emergency stops or heavy shock load. (Admissible stops per life of gearhead = 1,000 stops maximum.)

³⁾ For additional motor shaft sizes or smaller inertia value, please visit configurator.stober.com

* ME= Motor Adapter L=Large Input Option

PH Series: INLINE – Flange Output

Exact Ratio (i)	Output Torque				Backlash $\Delta\phi_2$	Red. Backlash $\Delta\phi_{2red}$	Part Number* (Gearhead + Input)	Max. Input Speed RPM (n1)		Motor Shaft ³⁾ Max ϕ d_{MW}	Input Inertia J_1	Tors. Stiffness C_2	Oper. Noise L_{PA}
	Nom. ¹⁾ M_{2N}	Accel. M_{2acc}	Accel. Torque for Reduced Backlash M_{2accHT}	Peak ²⁾ M_{2NOT}				Cont.	Cyclic				
	Nm	Nm	Nm	Nm				arcmin	arcmin				

PH7

4.000	440	840	924	1321	3	1	PH731_0040 ME	1900	4000	≤ 38	12	207	63
				1680			PH731_0040 MEL			≤ 48	22	219	
5.000	440	882	924	1651	3	1	PH731_0050 ME	2200	5000	≤ 38	9.5	190	61
				1720			PH731_0050 MEL			≤ 48	20	196	
7.000	440	869	869	1720	3	1	PH731_0070 ME	2500	5000	≤ 38	8.0	160	60
							PH731_0070 MEL			≤ 48	18	162	
10.00	350	575	575	1150	3	1	PH731_0100 ME	2500	5000	≤ 38	7.2	123	58
							PH731_0100 MEL			≤ 48	17		
16.00	450	740	740	1480	3	1	PH732_0160 ME	3000	6000	≤ 32	3.8	200	62
							PH732_0160 MEL			≤ 38	7.3		
20.00	460	805	845	1610	3	1	PH732_0200 ME	3000	6000	≤ 32	3.4	186	62
							PH732_0200 MEL			≤ 38	6.9		
25.00	500	866	908	1720	3	1	PH732_0250 ME	3500	7000	≤ 32	3.3	185	60
							PH732_0250 MEL			≤ 38	6.8		
28.00	540	770	880	1540	3	1	PH732_0280 ME	3700	7000	≤ 32	3.6	194	59
							PH732_0280 MEL			≤ 38	7.1		
35.00	540	866	908	1720	3	1	PH732_0350 ME	3700	7000	≤ 32	3.2	183	59
							PH732_0350 MEL			≤ 38	6.7		
40.00	540	770	770	1540	3	1	PH732_0400 ME	3700	7000	≤ 32	3.5	182	57
							PH732_0400 MEL			≤ 38	7.1		
50.00	600	830	834	1660	3	1	PH732_0500 ME	3700	7000	≤ 32	3.2	176	57
							PH732_0500 MEL			≤ 38	6.7		
70.00	600	809	847	1617	3	1	PH732_0700 ME	3700	7000	≤ 32	2.9	154	57
							PH732_0700 MEL			≤ 38	6.4		
100.0	423	550	550	1100	3	1	PH732_1000 ME	3700	7000	≤ 32	2.7	121	57
							PH732_1000 MEL			≤ 38	6.2		

¹⁾ Based on input speed of 1500 RPM. See page 34 for details on torque calculations.

²⁾ Maximum momentary torque for emergency stops or heavy shock load. (Admissible stops per life of gearhead = 1,000 stops maximum.)

³⁾ For additional motor shaft sizes or smaller inertia value, please visit configurator.stober.com

* ME= Motor Adapter L=Large Input Option



PH Series: INLINE — Flange Output

Exact Ratio (i)	Output Torque						Part Number* (Gearhead + Input)	Max. Input Speed RPM (n1)		Motor Shaft ³⁾ Max Ø d _{MW} mm	Input Inertia J ₁ kgcm ²	Tors. Stiffness C ₂ Nm/arcmin	Oper. Noise L _{PA} dB(A)
	Nom. ¹⁾ M _{2N}	Accel. M _{2acc}	Accel. Torque for Reduced Backlash M _{2accHT}	Peak ²⁾ M _{2NOT}	Backlash Δφ ₂ arcmin	Red. Backlash Δφ _{2red} arcmin		Cont.	Cyclic				
	Nm	Nm	Nm	Nm	arcmin	arcmin							

PH8

4.000	880	1820	2112	2408	3	1	PH831_0040 ME	1400	3500	≤48	44	512	64
				3639			PH831_0040 MEL			≤60		72	
5.000	1100	2100	2300	3010	3	1	PH831_0050 ME	1600	4000	≤48	33	534	62
				4200			PH831_0050 MEL			≤60		62	
7.000	1000	2000	2112	4000	3	1	PH831_0070 ME	2000	4000	≤48	26	441	61
							PH831_0070 MEL			≤60		54	
10.00	850	1392	1392	2784	3	1	PH831_0100 ME	2200	4000	≤48	22	338	59
							PH831_0100 MEL			≤60		50	
16.00	1100	2000	2200	4000	3	1	PH832_0160 ME	2500	4500	≤38	11	490	63
							PH832_0160 MEL			≤48		22	
20.00	1250	2100	2300	4200	3	1	PH832_0200 ME	2500	4500	≤38	9.4	518	63
							PH832_0200 MEL			≤48		20	
25.00	1300	2100	2300	4200	3	1	PH832_0250 ME	2700	5500	≤38	9.0	516	61
							PH832_0250 MEL			≤48		19	
28.00	1100	2000	2000	4000	3	1	PH832_0280 ME	3000	6000	≤38	10	477	60
							PH832_0280 MEL			≤48		20	
35.00	1450	2100	2300	4200	3	1	PH832_0350 ME	3000	6000	≤38	8.7	509	60
							PH832_0350 MEL			≤48		19	
40.00	1100	1920	1936	3840	3	1	PH832_0400 ME	3000	6000	≤38	9.9	452	58
							PH832_0400 MEL			≤48		20	
50.00	1557	2100	2300	4200	3	1	PH832_0500 ME	3000	6000	≤38	8.5	490	58
							PH832_0500 MEL			≤48		19	
70.00	1422	1848	1936	3696	3	1	PH832_0700 ME	3000	6000	≤38	7.5	425	58
							PH832_0700 MEL			≤48		18	
100.0	1062	1380	1380	2760	3	1	PH832_1000 ME	3000	6000	≤38	6.9	333	58
							PH832_1000 MEL			≤48		17	

¹⁾ Based on input speed of 1500 RPM. See page 34 for details on torque calculations.

²⁾ Maximum momentary torque for emergency stops or heavy shock load. (Admissible stops per life of gearhead = 1,000 stops maximum.)

³⁾ For additional motor shaft sizes or smaller inertia value, please visit configurator.stober.com

* ME= Motor Adapter L=Large Input Option

PH Series: INLINE – Flange Output

Exact Ratio (i)	Output Torque						Part Number* (Gearhead + Input)	Max. Input Speed RPM (n1)		Motor Shaft ³⁾ Max Ø d _{MW}	Input Inertia J ₁	Tors. Stiffness C ₂	Oper. Noise L _{PA}
	Nom. ¹⁾ M _{2N}	Accel. M _{2acc}	Accel. Torque for Reduced Backlash M _{2accHT}	Peak ²⁾ M _{2NOT}	Backlash Δφ ₂	Red. Backlash Δφ _{2red}							
	Nm	Nm	Nm	Nm	arcmin	arcmin		Cont.	Cyclic	mm	kgcm ²	Nm/arcmin	dB(A)

PH9

12.00	3000	4608	–	6743	3	–	PH932_0120 ME	1800	3000	≤48	67	1110	66
							PH932_0120 MEL			≤60			
16.00	3000	5000	–	8956	3	–	PH932_0160 ME	2200	3500	≤48	37	1139	64
							PH932_0160 MEL			≤60			
18.00	3000	4500	–	9000	3	–	PH932_0180 ME	1800	3000	≤48	61	1084	66
							PH932_0180 MEL			≤60			
20.00	3000	5000	–	10,000	3	–	PH932_0200 ME	2500	4000	≤48	29	1142	62
							PH932_0200 MEL			≤60			
24.00	3000	4500	–	9000	3	–	PH932_0240 ME	2200	3500	≤48	34	1096	64
							PH932_0240 MEL			≤60			
28.00	3000	5000	–	10,000	3	–	PH932_0280 ME	2800	4500	≤48	21	1121	61
							PH932_0280 MEL			≤55			
30.00	3000	4500	–	9000	3	–	PH932_0300 ME	2500	4000	≤48	27	1097	62
							PH932_0300 MEL			≤60			
32.00	3000	4608	–	9216	3	–	PH932_0320 ME	2800	4500	≤48	20	1093	60
							PH932_0320 MEL			≤55			
40.00	2688	4608	–	9216	3	–	PH932_0400 ME	2800	4500	≤48	18	1046	59
							PH932_0400 MEL			≤55			
42.00	3000	4500	–	9000	3	–	PH932_0420 ME	2800	4500	≤48	20	1088	61
							PH932_0420 MEL			≤55			
48.00	3000	4500	–	9000	3	–	PH932_0480 ME	2800	4500	≤48	19	1076	60
							PH932_0480 MEL			≤55			
60.00	3000	4500	–	9000	3	–	PH932_0600 ME	2800	4500	≤48	17	1055	59
							PH932_0600 MEL			≤55			
61.00	2500	4250	–	9000	3	–	PHV933_0610 ME	2500	4500	≤38	10	845	62
							PHV933_0610 MEL			≤48			
91.00	2500	4250	–	9000	3	–	PHV933_0910 ME	2500	4500	≤38	8.7	836	62
							PHV933_0910 MEL			≤48			
121.0	2500	4250	–	9000	3	–	PHV933_1210 ME	2500	4500	≤38	7.7	804	62
							PHV933_1210 MEL			≤48			

¹⁾ Based on input speed of 1500 RPM. See page 34 for details on torque calculations.

²⁾ Maximum momentary torque for emergency stops or heavy shock load. (Admissible stops per life of gearhead = 1,000 stops maximum.)

³⁾ For additional motor shaft sizes or smaller inertia value, please visit configurator.stober.com

* ME= Motor Adapter L=Large Input Option



PH Series: INLINE — Flange Output

Exact Ratio (i)	Output Torque						Part Number* (Gearhead + Input)	Max. Input Speed RPM (n1)		Motor Shaft ³⁾ Max Ø d _{MW}	Input Inertia J ₁	Tors. Stiffness C ₂	Oper. Noise L _{PA}
	Nom. ¹⁾ M _{2N}	Accel. M _{2acc}	Accel. Torque for Reduced Backlash M _{2accHT}	Peak ²⁾ M _{2NOT}	Backlash Δφ ₂	Red. Backlash Δφ _{2red}							
	Nm	Nm	Nm	Nm	arcmin	arcmin		Cont.	Cyclic	mm	kgcm ²	Nm/arcmin	dB(A)

PH10

18.00	4608	6912	-	10,115	3	-	PH1032_0180 ME	1800	3000	≤48	64	1656	66
							PH1032_0180 MEL			≤60	101	1743	
24.00	4608	7500	-	13,434	3	-	PH1032_0240 ME	2200	3500	≤48	36	1684	64
							PH1032_0240 MEL			≤60	72	1733	
30.00	5000	7500	-	15,000	3	-	PH1032_0300 ME	2500	4000	≤48	28	1686	62
							PH1032_0300 MEL			≤60	65	1718	
42.00	5000	7500	-	15,000	3	-	PH1032_0420 ME	2800	4500	≤48	21	1666	61
							PH1032_0420 MEL			≤55	53	1685	
48.00	4608	6912	-	13,824	3	-	PH1032_0480 ME	2800	4500	≤48	20	1638	60
							PH1032_0480 MEL			≤55	52	1652	
60.00	4032	6912	-	13,824	3	-	PH1032_0600 ME	2800	4500	≤48	18	1591	59
							PH1032_0600 MEL			≤55	50	1599	
61.00	4000	7500	-	15,000	3	-	PHV1033_0610 ME	2500	4500	≤48	24	1364	63
							PHV1033_0610 MEL			≤55	55	1368	
91.00	4000	7500	-	15,000	3	-	PHV1033_0910 ME	2500	4500	≤48	19	1339	63
							PHV1033_0910 MEL			≤55	51	1341	

¹⁾ Based on input speed of 1500 RPM. See page 34 for details on torque calculations.

²⁾ Maximum momentary torque for emergency stops or heavy shock load. (Admissible stops per life of gearhead = 1,000 stops maximum.)

³⁾ For additional motor shaft sizes or smaller inertia value, please visit configurator.stober.com

* ME= Motor Adapter L=Large Input Option