

## P Series: INLINE — Shaft Output

### P Features

- 3:1 to 100:1 ratios (higher ratios available. Contact STÖBER.)
- Quiet running (as low as 54dB(A))
- Bearing options to suit your application needs.
- Large motor input option to accept bigger diameter motor shafts so you don't use an oversized gearbox
- Error free motor mounting and quick changeover with toleranced pilot on motor plate
- Low no load running torque (see page 19), giving you more torque for your application
- Magnetic oil filtration to remove contaminants to prevent breakdowns
- Build and ship in one day
- Assembled in the USA

*STÖBER P Series Servo Precision Planetary Gearheads feature HeliCamber® gearing and other components which make them the most accurate and efficient planetary gearheads available. Our gear technology provides minimum wear, low backlash and low noise. Keyed, keyless, bearing options, and more are all available in one day. Every gearbox is made to order. STÖBER will custom whatever you need to fit your application. Contact us today to learn more.*

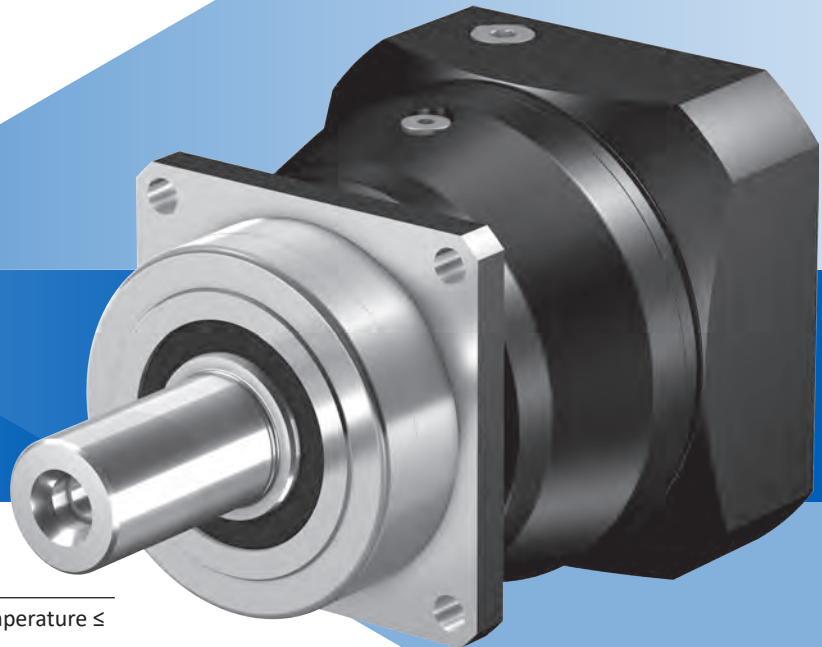

**All P Series  
SHIP in 1 DAY!**

**NO EXPEDITE FEE FOR 24  
HOUR SERVICE**

### General Specifications

<b>Ambient Temperature</b>	0° C to +40°C (104° F) [Unit temperature ≤ 90° C Max.]
<b>Backlash</b>	1-8 arcmins, see performance overview chart, page 16
<b>Coating</b>	Standard Black (RAL-9005); food duty optional (P3 thru P5 only)
<b>Degree of Protection</b>	IP65
<b>Direction of Rotation</b>	Input and output rotate the SAME direction
<b>Efficiency</b>	1 stage 97%; 2 stage 95%
<b>Input RPM</b>	Up to 8,000 rpm
<b>Installation</b>	Requires grade 10.9 fasteners. See page 306, for more information
<b>Lubrication</b>	Lubricated for life – standard Mobil SHC629; option food grade Mobil SHC CIBUS 150
<b>Mounting Position</b>	Unrestricted
<b>Warranty</b>	5 Year Limited (2 years on normal wear items: bearings, seals, etc.)

# Overview





## Selection Options At-a-Glance

Using the **Selection Data** table later in this section, select the P Series Gearhead with the appropriate performance and design options tailored to your motor choice and exact application requirements. Use the part number guide below as a reference to build a part number for the complete gearhead assembly.

**Part Number Examples:**

1	2	3	4	5	6	7	8	9	0	!
P	4	3	1	S	G	S	S	0030	ME	L

**P Series: INLINE — Shaft Output**

Design Option	Part Number Code	Description
<b>1 Series</b>	<b>P</b>	Solid shaft inline style planetary
<b>2 Size</b>	<b>2 3 4</b> <b>5 7 8 9</b>	7 sizes of gearhead
<b>3 Generation</b>	<b>3</b>	Version of gearhead
<b>4 # of Stages</b>	<b>1</b> <b>2</b>	One stage for ratios of ≤ 10:1 Two stage for ratios >10:1
<b>5 Housing</b>	<b>S</b>	Standard mounting style
<b>6 Output</b>	<b>P</b> <b>G</b>	Shaft with key Plain shaft (no key)
<b>7 Bearings</b> See output bearing options page 18	 <b>S</b>	Ball bearing
	 <b>D</b>	Double row angular contact bearing (except P2)
	 <b>Z</b>	Cylindrical roller bearing (P Series only, except P2)(“Z” cylindrical roller bearing not allowed with reduced backlash option.)
<b>8 Backlash</b>	<b>S</b> <b>R</b>	Standard Backlash Reduced Backlash
<b>9 Ratio</b>	<b>0030</b>	Ratios range from 3:1 to 100:1 (0030=3:1; 0160=16:1; 1000=100:1, etc.)
<b>0 Motor Adapter</b>	<b>ME</b>	Motor Adapter with EasyAdapt coupling
	<b>MF</b>	Motor Adapter with FlexiAdapt coupling (Contact factory for this option)
	<b>MB</b>	ServoStop motor adapter with brake (Contact factory for this option)
<b>! Options</b>	<b>L</b>	Large Input
	<b>F</b>	Food Duty (size P3 thru P5 only)

## Options

### ME Adapter Option

- MSS1 Seal – special input seal for longer life (for sizes P5-9). Contact factory for this option.

### Integrated Safety Brake

- ServoStop – provides dynamic braking during power failures or emergency stops in hazardous situations. Contact factory for this option.

### Coating Options

- **Standard:** For dry areas and normal conditions. All units standard coating, unless ordered with Food Duty.
- **Food Duty:** Able to withstand severe wet areas and washdown application (size P3 thru P5 only).

### Large Input

- Accommodates a larger diameter motor shaft without going to a larger size gearbox.

### ATEX

- ATmosphere EXplosible – rated for explosive environments. Contact factory for this option and allow additional time for delivery.

# P Series: INLINE — Shaft Output

## P Series Performance Overview

P Series performance is dependent on several factors including duty cycle, bearing design, gearhead size and stage configuration, among others. Use the chart below for preliminary evaluation, then use the following performance chart and selection information on the following pages for specific performance sizing and selection.

Series-Size	P2		P3		P4		P5		P7		P8		P9			
	1	2	1	2	1	2	1	2	1	2	1	2	1	2		
<b>Acceleration Torque</b> $M_{2BMAX}$	N		25		75		139		355		805		1840		3450	
<b>Output Torque Nom.</b> <sup>1)</sup> $M_{2N}$	N		19		53		102		270		584		1415		2483	
<b>Torsional Stiffness</b> $C_2$	Nm/arcmin		1.9		5		12		34		67		181		407	
<b>Torsional Backlash</b> <sup>2)</sup> $\Delta\phi$ Reduced	arcmin		≤6	≤8	≤4	≤5	≤4	≤5	≤3	≤4	≤3	≤4	≤3	≤4	≤3	≤4
<b>Input Speed Max.</b> $n_{1MAX}$	Continuous		6000	6000	5500	6000	4000	5000	3700	4000	3000	3700	2800	3000	2500	2800
	Cyclic		8000	8000	8000	8000	8000	8000	6700	8000	6000	7000	4500	6000	4000	4500
<b>Efficiency (@ nom torque)</b>	%		97	95	97	95	97	95	97	95	97	95	97	95	97	95
<b>Weight</b>	kg		1.5	2.1	2.5	2.6	4.3	5	7.2	8.5	16.9	16.4	34	37.2	50	67.5
	lbs		3.3	4.6	5.5	5.7	9.5	11	15.8	19	37.2	36	74.8	81.8	110	148.5
<b>Noise</b> <sup>3)</sup>	dB(A)		≤54	≤54	≤55	≤54	≤56	≤55	≤57	≤56	≤58	≤57	≤59	≤58	≤60	≤59

### Performance by Bearing Design Option <sup>4)</sup>

S = Ball bearing    D = Double row angular contact bearing    Z = Cylindrical roller bearing <sup>5)</sup>

		P2	P3	P4	P5	P7	P8	P9
<b>Axial Load</b> $F_{2ax100}$	S	500	1000	1500	2300	2900	4700	6000
	D	—	2500	4000	6000	10,000	15,500	25,000
	Z	—	600	1000	1600	2000	3600	5000
<b>Radial Load Max</b> $F_{2rad100}$	S	1200	2500	4000	6500	8500	13,000	18,000
	D	—	2750	4500	7000	9500	15,000	20,000
	Z	—	3000	5000	8000	10,000	18,000	27,000
<b>Tilting Moment Max</b> $M_{2K100}$	S	34	79	146	315	544	852	1539
	D	—	94	182	382	665	1095	1930
	Z	—	95	183	388	640	1179	2309

<sup>1)</sup> Ratings based on input speed ( $n_1$ ) of 1500 RPM.

For torque at higher input speeds ( $M_{2NX}$ ) solve the formula:  
where  $n_1$  = Actual Input Speed.

$$M_{2NX} = \frac{M_{2N}}{\sqrt[3]{\frac{n_1}{1500}}}$$

<sup>2)</sup> Tested at 1.5% of nominal torque and recorded on the output side of the gearhead.

<sup>3)</sup> Measurement at one (1) meter distance with input speed ( $n_1$ ) of 1500 RPM.

<sup>4)</sup> See page 18 for output bearing options. Rating based on output speed ( $n_2$ ) of 100 RPM. For values at other speeds see page 19.

<sup>5)</sup> "Z" cylindrical roller bearing not allowed with reduced backlash option.

### Backlash Options In Stock

All standard backlash options are in stock and ship in one day. These reduced backlash options are in stock and ship in one day.

	P331	P431	P432	P531	P532	P731
<b>Ratio</b>	0030 0070 0100	0030 0050 0080	0200	0030 0040 0100	0350	0030

# Overview



## P Series Motor Mounting Plate Option (Motor information required with ME or MF Motor Adapter Option)

STÖBER Servo Gearheads fit the motor of your choice with the appropriate motor mounting plate assembled between the motor and the gearhead.

### NOTE: When ordering a gearhead:

- Specify the motor manufacturer and part number
- Provide the motor drawing with dimensions, or specify the motor mounting dimensions (per the list shown at right)

For a precise dimension on a specific motor, or for general assistance, we recommend you contact STÖBER Technical Support.

Maximum 10 working days for custom motor mounting plates.

### Customer Required Dimensions for Properly Sized Motor Mounting Plate

- d2 Motor Shaft Diameter (If an adapter bushing is required it will be supplied with the motor plate.)
- b6 Pilot Diameter
- e6 Bolt Circle Diameter
- s6 Bolt Diameter
- l5 Motor Shaft Length
- f6 Pilot Length
- a6 Square Flange (Optional – motor plate will typically be made to match this dimension.)

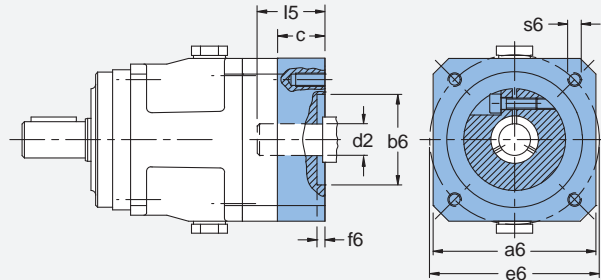

### Motor Mounting Plate Dimensions — mm(Gearhead Part Number Specific)

	P231 P232 P332	P231...L P232...L P331 P332...L P432	P331...L P431 P432...L P532	P431...L P531 P532...L P732	P531...L P731 P732...L P832	P731...L P831 P832...L P932	P831...L P931 P932...L
Maximum Allowed Motor Shaft Dia. d2	14	19	24	32	38	48	60
Minimum Allowed Motor Plate Thickness c*	15	18	21	24	26	35	43

\* Note that c motor plate thickness is determined by the motor shaft length. The minimum motor plate thickness is the value listed.

## P Series Output Shaft Options ("P" or "G" designated in part number, for example: P421S P 0160 MEL)

### P Shaft with Key

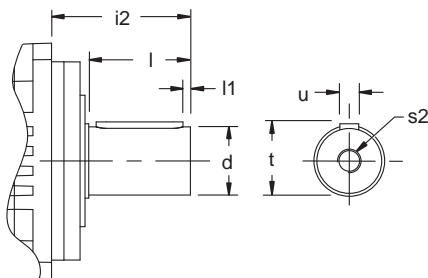

Unit	d k6		l1	l	i2	s2 <sup>(1)</sup>	t	u <sup>(2)</sup>
	mm							
P2	12	+0.012/+0.001	2	22	36	M4	13.5	A4X4X18
P3	16	+0.012/+0.001	2	28	48	M5	18	A5X5X22
P4	22	+0.015/+0.002	3	36	56	M8	24.5	A6X6X28
P5	32	+0.018/+0.002	3	58	88	M12	35	A10X8X50
P7	40	+0.018/+0.002	4	82	112	M16	43	A12X8X70
P8	55	+0.021/+0.002	6	82	112	M20	59	A16X10X70
P9	75	+0.021/+0.002	7	105	143	M20	79.5	A20X12X90

### G Shaft without Key

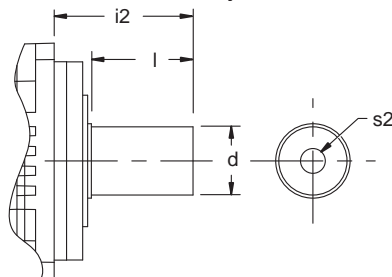

Unit	d k6		l	i2	s2 <sup>(1)</sup>
	mm				
P2	12	+0.012/+0.001	22	36	M4
P3	16	+0.012/+0.001	28	48	M5
P4	22	+0.015/+0.002	36	56	M8
P5	32	+0.018/+0.002	58	88	M12
P7	40	+0.018/+0.002	82	112	M16
P8	55	+0.021/+0.002	82	112	M20
P9	75	+0.021/+0.002	105	143	M20

<sup>(1)</sup> The center hole in shafts with keys (Option "P") are machined to DIN 332 T2 shape DR.

<sup>(2)</sup> Feather keys are toleranced according to standard DIN 6885.

# P Series: INLINE – Shaft Output

## P Series Output Bearing Options

### S Ball Bearing

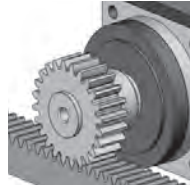

### D Double Row Angular Contact Bearing

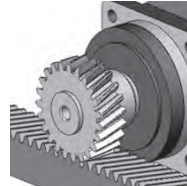

### Z Cylindrical Roller Bearing

("Z" cylindrical roller bearing not allowed with reduced backlash option.)

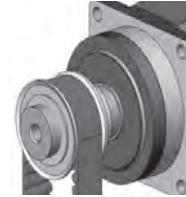

<b>Characteristics:</b>	<ul style="list-style-type: none"> <li>Minimal frictional torque</li> <li>Good radial load capacity</li> <li>Axial load approx. 35% of radial load</li> </ul>	<ul style="list-style-type: none"> <li>Low frictional torque</li> <li>Good radial bearing capacity</li> <li>Axial load approx. 50% of radial load</li> </ul>	<ul style="list-style-type: none"> <li>Very good radial load capacity</li> <li>Axial load approx. 20% of radial load</li> </ul>
<b>Applications:</b>	<ul style="list-style-type: none"> <li>Spur geared rack/pinion</li> <li>Couplings</li> <li>Belt with or without light tension</li> </ul>	<ul style="list-style-type: none"> <li>Helical geared rack/pinion</li> <li>Couplings with high axial load</li> <li>Belt with or without light tension</li> </ul>	<ul style="list-style-type: none"> <li>Prestressed belt drive</li> <li>Prestressed spur rack drive</li> <li>Applications with high radial loads and/or high service requirements</li> </ul>

## Permissible Output Shaft Load and Tilting Moments\*

	$Z_2$ Distance of Shaft Shoulder to Center of Output Bearing	$F_{2ax100}$ Permitted Axial Force	$F_{2rad100}$ Permitted Radial Force $\leq 100$ RPM	$F_{2rad,acc}$ Radial Acceleration Force	$M_{2K100}$ Permitted Tilting Torque $\leq 100$ RPM	$M_{2k,acc}$ Permitted Acceleration Tilting Torque
Unit	mm	N	N	N	Nm	Nm
<b>S Ball Bearing</b>						
P2	17	500	1200	1300	34	36
P3	17.5	1000	2500	2500	79	79
P4	18.5	1500	4000	4500	146	164
P5	19.5	2300	6500	7000	315	340
P7	23	2900	8000	9000	544	576
P8	24.5	4700	13,000	18,000	852	1179
P9	33	6000	18,000	27,000	1539	2309
<b>D Double Row Angular Contact Bearing</b>						
P3	20	2500	2750	2750	94	94
P4	22.5	4000	4500	5000	182	203
P5	25.5	6000	7000	8000	382	436
P7	29	10,000	9000	10,000	665	700
P8	32	15,500	15,000	18,000	1095	1314
P9	44	25,000	20,000	30,000	1930	2895
<b>Z Cylindrical Roller Bearing</b>						
P3	17.5	600	3000	3000	95	95
P4	18.5	1000	5000	5000	183	183
P5	19.5	1600	8000	8000	388	388
P7	23	2000	10,000	10,000	640	640
P8	24.5	3600	18,000	18,000	1179	1179
P9	33	5000	27,000	35,000	2309	2993

\* Refer to illustration and load/life/speed definitions on page 19

During EMERGENCY OFF operation (maximum stops per gearhead = 1000) the permissible values in the table for  $F_{2ax100}$ ,  $F_{2rad100}$ , and  $M_{2K100}$  can be multiplied by a factor of 2.

The permissible load values given are valid with the load applied to the center of the output shaft ( $x_2$ ).

# Overview



P Series: INLINE — Shaft Output

## P No Load Running Torque\*

Unit	Input Ratio $T_r$																			
	One Stage							Two Stage												
	3	4	5	7	8	10	12	16	20	25	28	32	35	40	50	56	70	80	100	
P2 Nm	—	0.16	0.13	0.13	0.13	0.10	—	0.13	0.13	0.08	0.08	0.08	0.08	0.08	0.08	0.08	0.08	0.08	0.08	0.08
P3 Nm	0.26	0.21	0.16	0.16	0.16	0.16	0.13	0.13	0.13	0.08	0.08	0.13	0.08	0.08	0.08	0.08	0.08	0.08	0.08	0.08
P4 Nm	0.33	0.23	0.23	0.18	0.18	0.18	0.14	0.14	0.14	0.11	0.11	0.14	0.11	0.11	0.11	0.11	0.11	0.11	0.11	0.11
P5 Nm	0.60	0.45	0.40	0.30	0.20	0.20	0.23	0.23	0.23	0.18	0.18	0.23	0.18	0.18	0.18	0.18	0.18	0.18	0.18	0.18
P7 Nm	0.83	0.53	0.43	0.33	0.23	0.23	0.30	0.30	0.30	0.20	0.20	0.30	0.20	0.20	0.20	0.20	0.20	0.20	0.20	0.20
P8 Nm	1.05	0.75	0.65	0.45	0.35	0.35	0.48	0.43	0.43	0.33	0.33	0.43	0.23	0.23	0.23	0.23	0.23	0.23	0.23	0.23
P9 Nm	—	0.92	0.72	0.52	—	0.42	—	0.55	0.55	0.45	0.45	—	0.35	0.35	0.35	—	0.35	—	0.35	

\* Torque is measured with the input at 2000 RPM and an ambient temperature of 20° C.

## Permissible Motor Tilting Torque

The permissible tilting torque of the motor attached to the gear unit is a result of the static and dynamic load "F" from the motor weight, mass acceleration, and vibration multiplied by the distance from the center of gravity "l<sub>s</sub>" of the motor.

$M_{1K}$	P231	P331	P431	P531	P731	P831	P931
	P232	P432	P532	P832	P932		
Nm	10	20	40	80	200	400	800

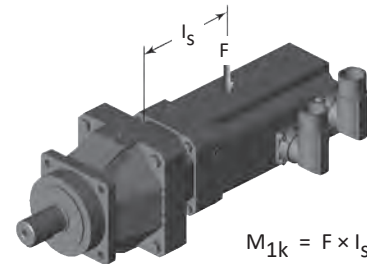

$$M_{1k} = F \times l_s \leq M_{1K}$$

## P Series Load/Life/Speed Calculations

The permissible load and tilting moment values are based on an output speed of 100 RPM. For higher speeds the following applies, where  $n_2$  is the desired speed:

$$F_{2Ax} = \frac{F_{2ax100}}{\sqrt[3]{\frac{n_2}{100}}}, \quad F_{2Rax} = \frac{F_{2rad100}}{\sqrt[3]{\frac{n_2}{100}}}, \quad M_{2Kx} = \frac{M_{2k100}}{\sqrt[3]{\frac{n_2}{100}}}$$

The application output tilting moment should be determined by the following formula:

$$M_{2k,acc*} = \frac{2 \cdot F_{2ax100} \cdot y_2 + F_{2rad,acc} \cdot (x_2 + z_2)}{1000} \leq M_{2k,acc}$$

$$M_{2k,eq*} = \sqrt{\frac{n_{2b1} \cdot t_{b1} \cdot M_{2kb1}^3 + \dots + n_{2bn} \cdot t_{bn} \cdot M_{2kbn}^3}{n_{2b1} \cdot t_{b1} + \dots + n_{2bn} \cdot t_{bn}}} \leq M_{2kN}$$

$$F_{2rad,eq*} = \sqrt[3]{\frac{n_{2b1} \cdot t_{b1} \cdot F_{2rb1}^3 + \dots + n_{2bn} \cdot t_{bn} \cdot F_{2rbn}^3}{n_{2b1} \cdot t_{b1} + \dots + n_{2bn} \cdot t_{bn}}} \leq F_{2radN}$$

Where:

- $Z_2$  Distance of Shaft Shoulder to Center of Output Bearing
- $n_2$  Actual Average Output Speed
- $x_2$  Distance of the Shaft Shoulder to the Force Application Point
- $y_2$  Distance of the Shaft Axis to the Axial Force Application Point
- $F_{2ax*}$  Actual Axial Force at Gear Unit Output
- $F_{2ax100}$  Permitted Axial Force
- $F_{2rad100}$  Permitted Radial Force ≤100RPM
- $F_{2rad,acc}$  Radial Acceleration Force
- $F_{2rad,acc*}$  Radial Acceleration Force at Gear Unit Output
- $M_{2K100}$  Permitted Tilting Torque ≤100RPM
- $M_{2K,acc}$  Permitted Acceleration Tilting Torque
- $M_{2k,acc*}$  Permitted Acceleration Tilting Torque at Gear Unit Output
- $C_{2K}$  Tilting Stiffness

All formulas shown are based on METRIC values  
Upper case letters are permissible values. Lower case letters are for existing values.

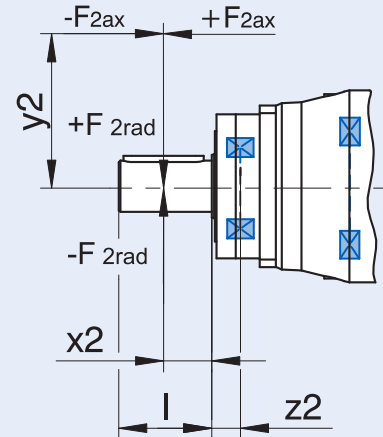

The hours of life ( $L_h$ ) of the unit can be determined by the following formula:

**bearing life for duty cycle ≤ 40%**  
 $L_h > 10,000$  hours if  $M_{2k100}/M_{2A} < 1.25$  and  $> 1$   
 $L_h > 20,000$  hours if  $M_{2k100}/M_{2A} > 1.25$  and  $> 1.5$   
 $L_h > 30,000$  hours if  $M_{2k100}/M_{2A} < 1.5$

**bearing life for duty cycle ≥ 40%**

$$L_{hA} = L_h \left( \frac{40\%}{\text{Duty Cycle}} \right)$$

# P Series: INLINE – Shaft Output

Exact Ratio (i)	Output Torque						Part Number* (Gearhead + Input)	Max. Input Speed RPM (n1)		Motor Shaft <sup>3)</sup> Max Ø d <sub>MW</sub>	Input Inertia J <sub>1</sub>	Tors. Stiffness C <sub>2</sub>	Oper. Noise L <sub>PA</sub>
	Nom. <sup>1)</sup> M <sub>2N</sub>	Accel. M <sub>2acc</sub>	Accel. Torque for Reduced Backlash M <sub>2accHT</sub>	Peak <sup>2)</sup> M <sub>2NOT</sub>	Backlash Δφ <sub>2</sub>	Red. Backlash Δφ <sub>2red</sub>							
	Nm	Nm	Nm	Nm	arcmin	arcmin		Cont.	Cyclic	mm	kgcm <sup>2</sup>	Nm/arcmin	dB(A)

## P2

4.000	16	25	–	51	6	–	P231_0040 ME	6000	8000	≤14	0.14	1.8	59
							P231_0040 MEL			≤19	0.43	1.9	
5.000	16	25	–	51	6	–	P231_0050 ME	6000	8000	≤14	0.12	1.9	57
							P231_0050 MEL			≤19	0.41		
7.000	16	23	–	46	6	–	P231_0070 ME	6000	8000	≤14	0.11	1.8	56
							P231_0070 MEL			≤19	0.40		
8.000	14	21	–	41	6	–	P231_0080 ME	6000	8000	≤14	0.10	1.7	55
							P231_0080 MEL			≤19	0.40		
10.00	12	21	–	41	6	–	P231_0100 ME	6000	8000	≤14	0.10	1.6	54
							P231_0100 MEL			≤19	0.39		
16.00	16	24	–	48	8	–	P232_0160 ME	6000	8000	≤14	0.14	1.8	59
							P232_0160 MEL			≤19	0.42		
20.00	16	25	–	51	8	–	P232_0200 ME	6000	8000	≤14	0.14	1.8	59
							P232_0200 MEL			≤19	0.42		
25.00	16	25	–	51	8	–	P232_0250 ME	6000	8000	≤14	0.12	1.8	57
							P232_0250 MEL			≤19	0.40		
28.00	16	24	–	48	8	–	P232_0280 ME	6000	8000	≤14	0.11	1.8	56
							P232_0280 MEL			≤19	0.40		
32.00	16	21	–	41	8	–	P232_0320 ME	6000	8000	≤14	0.14	1.7	59
							P232_0320 MEL			≤19	0.42		
35.00	18	25	–	51	8	–	P232_0350 ME	6000	8000	≤14	0.11	1.8	56
							P232_0350 MEL			≤19	0.40		
40.00	16	24	–	48	8	–	P232_0400 ME	6000	8000	≤14	0.10	1.8	54
							P232_0400 MEL			≤19	0.39		
50.00	19	25	–	51	8	–	P232_0500 ME	6000	8000	≤14	0.10	1.8	54
							P232_0500 MEL			≤19	0.39		
56.00	16	21	–	41	8	–	P232_0560 ME	6000	8000	≤14	0.11	1.7	56
							P232_0560 MEL			≤19	0.40		
70.00	18	23	–	46	8	–	P232_0700 ME	6000	8000	≤14	0.10	1.8	58
							P232_0700 MEL			≤19	0.40		
80.00	16	21	–	41	8	–	P232_0800 ME	6000	8000	≤14	0.10	1.7	54
							P232_0800 MEL			≤19	0.39		
100.0	16	21	–	41	8	–	P232_1000 ME	6000	8000	≤14	0.10	1.6	54
							P232_1000 MEL			≤19	0.39		

<sup>1)</sup> Based on input speed of 1500RPM. See page 16 for details on torque calculations.

<sup>2)</sup> Maximum momentary torque for emergency stops or heavy shock load. (Admissible stops per life of gearhead = 1,000 stops maximum.)

<sup>3)</sup> For additional motor shaft sizes or smaller inertia values, please visit [configurator.stober.com](http://configurator.stober.com)

\* ME = Motor Adapter L = Large Input

# Selection Data



P Series: INLINE — Shaft Output

Exact Ratio (i)	Output Torque						Part Number* (Gearhead + Input)	Max. Input Speed RPM (n1)		Motor Shaft <sup>3)</sup> Max Ø d <sub>MW</sub>	Input Inertia J <sub>1</sub>	Tors. Stiffness C <sub>2</sub>	Oper. Noise L <sub>PA</sub>
	Nom. <sup>1)</sup> M <sub>2N</sub>	Accel. M <sub>2acc</sub>	Accel. Torque for Reduced Backlash M <sub>2accHT</sub>	Peak <sup>2)</sup> M <sub>2NOT</sub>	Backlash Δφ <sub>2</sub>	Red. Backlash Δφ <sub>2red</sub>							
	Nm	Nm	Nm	Nm	arcmin	arcmin		mm	kgcm <sup>2</sup>	Nm/arcmin	dB(A)		

## P3

3.000	30	50	50	100	4	2	P331_0030 ME	3500	7000	≤19	0.67	5.0	62
							P331_0030 MEL			≤24	1.1		
4.000	45	65	65	130	4	2	P331_0040 ME	4000	8000	≤19	0.51	5.3	60
							P331_0040 MEL			≤24	0.94		
5.000	45	75	80	150	4	2	P331_0050 ME	4500	8000	≤19	0.46	5.4	58
							P331_0050 MEL			≤24	0.89		
7.000	45	69	75	138	4	2	P331_0070 ME	5000	8000	≤19	0.42	5.0	57
							P331_0070 MEL			≤24	0.85		
8.000	40	63	65	126	4	2	P331_0080 ME	5000	8000	≤19	0.41	4.6	56
							P331_0080 MEL			≤24	0.84		
10.00	36	60	60	120	4	2	P331_0100 ME	5500	8000	≤19	0.40	4.4	55
							P331_0100 MEL			≤24	0.83		
12.00	30	50	50	100	5	3	P332_0120 ME	5500	8000	≤14	0.15	4.6	59
							P332_0120 MEL			≤19	0.44		
16.00	45	65	65	130	5	3	P332_0160 ME	5500	8000	≤14	0.14	5.1	59
							P332_0160 MEL			≤19	0.43		
20.00	50	75	75	150	5	3	P332_0200 ME	5500	8000	≤14	0.14	5.2	59
							P332_0200 MEL			≤19	0.42		
25.00	50	75	75	150	5	3	P332_0250 ME	6000	8000	≤14	0.12	5.2	57
							P332_0250 MEL			≤19	0.41		
28.00	45	65	70	130	5	3	P332_0280 ME	6000	8000	≤14	0.10	5.1	56
							P332_0280 MEL			≤19	0.40		
32.00	48	63	65	126	5	3	P332_0320 ME	5500	8000	≤14	0.14	4.6	59
							P332_0320 MEL			≤19	0.42		
35.00	50	75	75	150	5	3	P332_0350 ME	6000	8000	≤14	0.10	5.2	56
							P332_0350 MEL			≤19	0.40		
40.00	45	65	65	130	5	3	P332_0400 ME	6000	8000	≤14	0.10	4.8	54
							P332_0400 MEL			≤19	0.39		
50.00	50	75	75	150	5	3	P332_0500 ME	6000	8000	≤14	0.10	5.0	54
							P332_0500 MEL			≤19	0.39		
56.00	48	63	65	126	5	3	P332_0560 ME	6000	8000	≤14	0.10	4.6	56
							P332_0560 MEL			≤19	0.40		
70.00	53	69	69	138	5	3	P332_0700 ME	6000	8000	≤14	0.10	4.9	54
							P332_0700 MEL			≤19	0.39		
80.00	48	63	65	126	5	3	P332_0800 ME	6000	8000	≤14	0.10	4.5	54
							P332_0800 MEL			≤19	0.39		
100.0	46	60	60	120	5	3	P332_1000 ME	6000	8000	≤14	0.10	4.3	54
							P332_1000 MEL			≤19	0.39		

<sup>1)</sup> Based on input speed of 1500RPM. See page 16 for details on torque calculations.

<sup>2)</sup> Maximum momentary torque for emergency stops or heavy shock load. (Admissible stops per life of gearhead = 1,000 stops maximum.)

<sup>3)</sup> For additional motor shaft sizes or smaller inertia values, please visit [configurator.stober.com](http://configurator.stober.com)

\* ME = Motor Adapter L = Large Input



# P Series: INLINE – Shaft Output

Exact Ratio (i)	Output Torque						Part Number* (Gearhead + Input)	Max. Input Speed RPM (n1)		Motor Shaft <sup>3)</sup> Max Ø d <sub>MW</sub>	Input Inertia J <sub>1</sub>	Tors. Stiffness C <sub>2</sub>	Oper. Noise L <sub>PA</sub>
	Nom. <sup>1)</sup> M <sub>2N</sub>	Accel. M <sub>2acc</sub>	Accel. Torque for Reduced Backlash M <sub>2accHT</sub>	Peak <sup>2)</sup> M <sub>2NOT</sub>	Backlash Δφ <sub>2</sub>	Red. Backlash Δφ <sub>2red</sub>							
	Nm	Nm	Nm	Nm	arcmin	arcmin		Cont.	Cyclic	mm	kgcm <sup>2</sup>	Nm/arcmin	dB(A)

## P4

3.000	50	100	100	200	4	2	P431_0030 ME	3000	6000	≤24	1.6	12	63
							P431_0030 MEL			≤32	3.2		
4.000	90	120	130	240	4	2	P431_0040 ME	3300	6500	≤24	1.2	13	61
							P431_0040 MEL			≤32	2.8		
5.000	90	139	145	277	4	2	P431_0050 ME	3700	7000	≤24	1.0	13	59
							P431_0050 MEL			≤32	2.7		
7.000	90	135	143	271	4	2	P431_0070 ME	4000	8000	≤24	0.92	11	58
							P431_0070 MEL			≤32	2.5		
8.000	80	120	125	239	4	2	P431_0080 ME	4000	8000	≤24	0.90	9.7	57
							P431_0080 MEL			≤32	2.5		
10.00	75	115	115	230	4	2	P431_0100 ME	4000	8000	≤24	0.88	9.1	56
							P431_0100 MEL			≤32	2.5		
12.00	60	100	100	200	5	3	P432_0120 ME	3500	7000	≤19	0.54	11	60
							P432_0120 MEL			≤24	0.97		
16.00	89	130	130	260	5	3	P432_0160 ME	4000	8000	≤19	0.51	12	60
							P432_0160 MEL			≤24	0.94		
20.00	95	134	139	268	5	3	P432_0200 ME	4000	8000	≤19	0.50	12	60
							P432_0200 MEL			≤24	0.93		
25.00	100	134	139	268	5	3	P432_0250 ME	4500	8000	≤19	0.46	12	58
							P432_0250 MEL			≤24	0.89		
28.00	95	130	130	260	5	3	P432_0280 ME	4500	8000	≤19	0.43	12	57
							P432_0280 MEL			≤24	0.86		
32.00	90	126	131	253	5	3	P432_0320 ME	4000	8000	≤19	0.49	9.6	60
							P432_0320 MEL			≤24	0.92		
35.00	102	133	138	266	5	3	P432_0350 ME	4500	8000	≤19	0.43	12	57
							P432_0350 MEL			≤24	0.86		
40.00	87	130	130	260	5	3	P432_0400 ME	5000	8000	≤19	0.41	12	55
							P432_0400 MEL			≤24	0.84		
50.00	102	132	138	264	5	3	P432_0500 ME	5000	8000	≤19	0.41	12	55
							P432_0500 MEL			≤24	0.83		
56.00	88	115	115	230	5	3	P432_0560 ME	5000	8000	≤19	0.42	9.6	57
							P432_0560 MEL			≤24	0.85		
70.00	97	127	127	253	5	3	P432_0700 ME	5000	8000	≤19	0.40	11	55
							P432_0700 MEL			≤24	0.83		
80.00	88	115	115	230	5	3	P432_0800 ME	5000	8000	≤19	0.40	9.6	55
							P432_0800 MEL			≤24	0.83		
100.0	85	110	110	220	5	3	P432_1000 ME	5000	8000	≤19	0.40	9.0	55
							P432_1000 MEL			≤24	0.83		

<sup>1)</sup> Based on input speed of 1500RPM. See page 16 for details on torque calculations.

<sup>2)</sup> Maximum momentary torque for emergency stops or heavy shock load. (Admissible stops per life of gearhead = 1,000 stops maximum.)

<sup>3)</sup> For additional motor shaft sizes or smaller inertia values, please visit [configurator.stober.com](http://configurator.stober.com)

\* ME = Motor Adapter L = Large Input

# Selection Data



P Series: INLINE — Shaft Output

Exact Ratio (i)	Output Torque						Part Number* (Gearhead + Input)	Max. Input Speed RPM (n1)		Motor Shaft <sup>3)</sup> Max Ø d <sub>MW</sub>	Input Inertia J <sub>1</sub>	Tors. Stiffness C <sub>2</sub>	Oper. Noise L <sub>PA</sub>
	Nom. <sup>1)</sup> M <sub>2N</sub>	Accel. M <sub>2acc</sub>	Accel. Torque for Reduced Backlash M <sub>2accHT</sub>	Peak <sup>2)</sup> M <sub>2NOT</sub>	Backlash Δφ <sub>2</sub>	Red. Backlash Δφ <sub>2red</sub>							
	Nm	Nm	Nm	Nm	arcmin	arcmin		Cont.	Cyclic	mm	kgcm <sup>2</sup>	Nm/arcmin	dB(A)

## P5

3.000	120	200	200	400	3	1	P531_0030 ME	2500	5000	≤32	5.3	33	64
							P531_0030 MEL			≤38	8.8		
4.000	210	300	320	600	3	1	P531_0040 ME	3000	6000	≤32	3.7	34	62
							P531_0040 MEL			≤38	7.2		
5.000	220	350	385	700	3	1	P531_0050 ME	3500	7000	≤32	3.2	34	60
							P531_0050 MEL			≤38	6.8		
7.000	210	333	380	667	3	1	P531_0070 ME	3700	7000	≤32	2.9	31	59
							P531_0070 MEL			≤38	6.4		
8.000	200	296	300	592	3	1	P531_0080 ME	3700	7000	≤32	2.8	25	58
							P531_0080 MEL			≤38	6.3		
10.00	180	288	288	575	3	1	P531_0100 ME	3700	7000	≤32	2.7	26	57
							P531_0100 MEL			≤38	6.2		
12.00	120	200	200	400	4	2	P532_0120 ME	3000	6000	≤24	1.3	31	61
							P532_0120 MEL			≤32	2.9		
16.00	220	300	300	600	4	2	P532_0160 ME	3500	7000	≤24	1.2	33	61
							P532_0160 MEL			≤32	2.8		
20.00	250	355	364	710	4	2	P532_0200 ME	3500	7000	≤24	1.1	33	61
							P532_0200 MEL			≤32	2.7		
25.00	260	355	357	710	4	2	P532_0250 ME	3700	7000	≤24	1.0	33	59
							P532_0250 MEL			≤32	2.6		
28.00	231	300	300	600	4	2	P532_0280 ME	4000	8000	≤24	0.95	32	58
							P532_0280 MEL			≤32	2.6		
32.00	240	312	363	624	4	2	P532_0320 ME	3500	7000	≤24	1.1	25	61
							P532_0320 MEL			≤32	2.7		
35.00	270	352	352	704	4	2	P532_0350 ME	4000	8000	≤24	0.94	33	58
							P532_0350 MEL			≤32	2.5		
40.00	214	300	300	600	4	2	P532_0400 ME	4000	8000	≤24	0.89	31	56
							P532_0400 MEL			≤32	2.5		
50.00	269	352	352	704	4	2	P532_0500 ME	4000	8000	≤24	0.89	32	56
							P532_0500 MEL			≤32	2.5		
56.00	221	288	288	575	4	2	P532_0560 ME	4000	8000	≤24	0.93	25	58
							P532_0560 MEL			≤32	2.5		
70.00	263	345	357	690	4	2	P532_0700 ME	4200	8000	≤24	0.88	30	56
							P532_0700 MEL			≤32	2.5		
80.00	221	288	288	575	4	2	P532_0800 ME	4200	8000	≤24	0.88	25	56
							P532_0800 MEL			≤32	2.5		
100.0	221	288	288	575	4	2	P532_1000 ME	4200	8000	≤24	0.88	26	56
							P532_1000 MEL			≤32	2.5		

<sup>1)</sup> Based on input speed of 1500RPM. See page 16 for details on torque calculations.

<sup>2)</sup> Maximum momentary torque for emergency stops or heavy shock load. (Admissible stops per life of gearhead = 1,000 stops maximum.)

<sup>3)</sup> For additional motor shaft sizes or smaller inertia values, please visit configurator.stober.com

\* ME = Motor Adapter L = Large Input

# P Series: INLINE – Shaft Output

Exact Ratio (i)	Output Torque						Part Number* (Gearhead + Input)	Max. Input Speed RPM (n1)		Motor Shaft <sup>3)</sup> Max Ø d <sub>MW</sub>	Input Inertia J <sub>1</sub>	Tors. Stiffness C <sub>2</sub>	Oper. Noise L <sub>PA</sub>
	Nom. <sup>1)</sup> M <sub>2N</sub>	Accel. M <sub>2acc</sub>	Accel. Torque for Reduced Backlash M <sub>2accHT</sub>	Peak <sup>2)</sup> M <sub>2NOT</sub>	Backlash Δφ <sub>2</sub>	Red. Backlash Δφ <sub>2red</sub>							
	Nm	Nm	Nm	Nm	arcmin	arcmin		mm	kgcm <sup>2</sup>	Nm/arcmin	dB(A)		

## P7

3.000	300	500	500	1000	3	1	P731_0030 ME	2200	4000	≤38	15	62	65
							P731_0030 MEL			≤48	26	64	
4.000	440	700	725	1335 1400	3	1	P731_0040 ME	2500	5000	≤38	10	65	63
							P731_0040 MEL			≤48	21	67	
5.000	440	805	840	1610	3	1	P731_0050 ME	2700	5500	≤38	8.8	65	61
							P731_0050 MEL			≤48	19	65	
7.000	440	805	840	1610	3	1	P731_0070 ME	3000	6000	≤38	7.6	60	60
							P731_0070 MEL			≤48	18	61	
8.000	400	668	700	1336	3	1	P731_0080 ME	3000	6000	≤38	7.3	57	59
							P731_0080 MEL			≤48	17	57	
10.00	350	575	575	1150	3	1	P731_0100 ME	3000	6000	≤38	7.0	54	58
							P731_0100 MEL			≤48	17	54	
12.00	295	500	500	1000	4	2	P732_0120 ME	2500	5000	≤32	4.1	61	62
							P732_0120 MEL			≤38	7.6	61	
16.00	450	700	700	1400	4	2	P732_0160 ME	3000	6000	≤32	3.7	65	62
							P732_0160 MEL			≤38	7.3	65	
20.00	460	805	805	1610	4	2	P732_0200 ME	3000	6000	≤32	3.6	64	62
							P732_0200 MEL			≤38	7.1	64	
25.00	500	805	805	1610	4	2	P732_0250 ME	3500	7000	≤32	3.3	64	60
							P732_0250 MEL			≤38	6.8	64	
28.00	538	700	700	1400	4	2	P732_0280 ME	3700	7000	≤32	3.0	64	59
							P732_0280 MEL			≤38	6.5	64	
32.00	470	730	730	1460	4	2	P732_0320 ME	3000	6000	≤32	3.5	57	62
							P732_0320 MEL			≤38	7.1	57	
35.00	540	770	805	1540	4	2	P732_0350 ME	3700	7000	≤32	2.9	64	59
							P732_0350 MEL			≤38	6.4	64	
40.00	454	700	700	1400	4	2	P732_0400 ME	3700	7000	≤32	2.7	63	57
							P732_0400 MEL			≤38	6.2	63	
50.00	565	770	805	1540	4	2	P732_0500 ME	3700	7000	≤32	2.7	63	57
							P732_0500 MEL			≤38	6.2	63	
56.00	500	650	650	1300	4	2	P732_0560 ME	3700	7000	≤32	2.9	57	59
							P732_0560 MEL			≤38	6.4	57	
70.00	584	762	799	1525	4	2	P732_0700 ME	3700	7000	≤32	2.7	60	57
							P732_0700 MEL			≤38	6.2	60	
80.00	477	620	620	1240	4	2	P732_0800 ME	3700	7000	≤32	2.7	57	57
							P732_0800 MEL			≤38	6.2	57	
100.0	423	550	550	1100	4	2	P732_1000 ME	3700	7000	≤32	2.7	54	57
							P732_1000 MEL			≤38	6.2	54	

<sup>1)</sup> Based on input speed of 1500RPM. See page 16 for details on torque calculations.

<sup>2)</sup> Maximum momentary torque for emergency stops or heavy shock load. (Admissible stops per life of gearhead = 1,000 stops maximum.)

<sup>3)</sup> For additional motor shaft sizes or smaller inertia values, please visit [configurator.stober.com](http://configurator.stober.com)

\* ME = Motor Adapter L = Large Input

# Selection Data



P Series: INLINE — Shaft Output

Exact Ratio (i)	Output Torque						Part Number* (Gearhead + Input)	Max. Input Speed RPM (n1)		Motor Shaft <sup>3)</sup> Max Ø d <sub>MW</sub> mm	Input Inertia J <sub>1</sub> kgcm <sup>2</sup>	Tors. Stiffness C <sub>2</sub> Nm/arcmin	Oper. Noise L <sub>PA</sub> dB(A)
	Nom. <sup>1)</sup> M <sub>2N</sub>	Accel. M <sub>2acc</sub>	Accel. Torque for Reduced Backlash M <sub>2accHT</sub>	Peak <sup>2)</sup> M <sub>2NOT</sub>	Backlash Δφ <sub>2</sub> arcmin	Red. Backlash Δφ <sub>2red</sub> arcmin		Cont.	Cyclic				
	Nm	Nm	Nm	Nm	arcmin	arcmin							

## P8

3.000	800	1200	1200	1825	3	1	P831_0030 ME	1800	3000	≤48	59	170	66
				2400			P831_0030 MEL			≤60	87	178	
4.000	880	1760	1760	2433	3	1	P831_0040 ME	2000	3500	≤48	36	176	64
				3230			P831_0040 MEL			≤60	64	180	
5.000	1100	1840	2000	3041	3	1	P831_0050 ME	2500	4000	≤48	28	178	62
				3230			P831_0050 MEL			≤60	56	181	
7.000	1000	1760	1840	3230	3	1	P831_0070 ME	2800	4500	≤48	23	167	61
							P831_0070 MEL			≤60	51	168	
8.000	850	1500	1500	3000	3	1	P831_0080 ME	2800	4500	≤48	21	160	60
							P831_0080 MEL			≤60	50	161	
10.00	850	1380	1380	2760	3	1	P831_0100 ME	2800	4500	≤48	20	149	59
							P831_0100 MEL			≤60	48		
12.00	800	1200	1200	2400	4	2	P832_0120 ME	2200	4500	≤38	12	166	63
							P832_0120 MEL			≤48	22	167	
16.00	1100	1600	1600	3200	4	2	P832_0160 ME	2700	5000	≤38	11	173	63
							P832_0160 MEL			≤48	21	174	
20.00	1250	1840	2000	3230	4	2	P832_0200 ME	2700	5000	≤38	10	176	63
							P832_0200 MEL			≤48	20	177	
25.00	1300	1840	2000	3230	4	2	P832_0250 ME	2900	5000	≤38	8.8	176	61
							P832_0250 MEL			≤48	19		
28.00	1100	1600	1600	3200	4	2	P832_0280 ME	3000	5000	≤38	7.8	171	60
							P832_0280 MEL			≤48	18	172	
32.00	1173	1525	1595	3049	4	2	P832_0320 ME	2700	5000	≤38	9.9	159	63
							P832_0320 MEL			≤48	20		
35.00	1415	1840	2000	3230	4	2	P832_0350 ME	3000	6000	≤38	7.6	175	60
							P832_0350 MEL			≤48	18		
40.00	1097	1600	1600	3200	4	2	P832_0400 ME	3000	6000	≤38	7.1	168	58
							P832_0400 MEL			≤48	17		
50.00	1415	1840	2000	3230	4	2	P832_0500 ME	3000	6000	≤38	7.0	173	58
							P832_0500 MEL			≤48	17		
56.00	1062	1380	1380	2760	4	2	P832_0560 ME	3000	6000	≤38	7.5	159	60
							P832_0560 MEL			≤48	18		
70.00	1238	1610	1610	3220	4	2	P832_0700 ME	3000	6000	≤38	7.0	164	58
							P832_0700 MEL			≤48	17		
80.00	1062	1380	1380	2760	4	2	P832_0800 ME	3000	6000	≤38	6.9	159	58
							P832_0800 MEL			≤48	17		
100.0	1015	1320	1320	2640	4	2	P832_1000 ME	3000	6000	≤38	6.9	148	58
							P832_1000 MEL			≤48	17		

<sup>1)</sup> Based on input speed of 1500RPM. See page 16 for details on torque calculations.

<sup>2)</sup> Maximum momentary torque for emergency stops or heavy shock load. (Admissible stops per life of gearhead = 1,000 stops maximum.)

<sup>3)</sup> For additional motor shaft sizes or smaller inertia values, please visit configurator.stober.com

\* ME = Motor Adapter L = Large Input

# P Series: INLINE – Shaft Output

Exact Ratio (i)	Output Torque						Part Number* (Gearhead + Input)	Max. Input Speed RPM (n1)		Motor Shaft <sup>3)</sup> Max Ø d <sub>MW</sub> mm	Input Inertia J <sub>1</sub> kgcm <sup>2</sup>	Tors. Stiffness C <sub>2</sub> Nm/arcmin	Oper. Noise L <sub>PA</sub> dB(A)
	Nom. <sup>1)</sup> M <sub>2N</sub>	Accel. M <sub>2acc</sub>	Accel. Torque for Reduced Backlash M <sub>2accHT</sub>	Peak <sup>2)</sup> M <sub>2NOT</sub>	Backlash Δφ <sub>2</sub> arcmin	Red. Backlash Δφ <sub>2red</sub> arcmin		Cont.	Cyclic				
	Nm	Nm	Nm	Nm	arcmin	arcmin							

## P9

4.000	2000	3000	–	5599	3	–	P931_0040 ME	1800	3000	≤60	100	407	65
5.000	2000	3450	–	6900	3	–	P931_0050 ME	2000	3500	≤60	82	407	63
7.000	2100	3105	–	6210	3	–	P931_0070 ME	2300	4000	≤60	69	375	62
10.00	1769	2300	–	4600	3	–	P931_0100 ME	2500	4000	≤60	62	323	60
16.00	2000	3000	–	6000	4	–	P932_0160 ME	2000	3500	≤48	37	403	64
							P932_0160 MEL			≤60	65	404	
20.00	2483	3450	–	6900	4	–	P932_0200 ME	2000	3500	≤48	35	405	64
							P932_0200 MEL			≤60	64	406	
25.00	2441	3300	–	6600	4	–	P932_0250 ME	2500	4000	≤48	28	405	62
							P932_0250 MEL			≤60	56	406	
28.00	2280	3000	–	6000	4	–	P932_0280 ME	2800	4500	≤48	23	401	61
							P932_0280 MEL			≤60	51		
35.00	2376	3300	–	6600	4	–	P932_0350 ME	2800	4500	≤48	23	403	61
							P932_0350 MEL			≤60	51	404	
40.00	2000	3000	–	6000	4	–	P932_0400 ME	2800	4500	≤48	20	394	59
							P932_0400 MEL			≤60	48		
50.00	2295	3200	–	6400	4	–	P932_0500 ME	2800	4500	≤48	20	399	59
							P932_0500 MEL			≤60	48		
70.00	2387	3156	–	6312	4	–	P932_0700 ME	2800	4500	≤48	20	372	59
							P932_0700 MEL			≤60	48		
100.0	1692	2200	–	4400	4	–	P932_1000 ME	2800	4500	≤48	20	321	59
							P932_1000 MEL			≤60	48		

<sup>1)</sup> Based on input speed of 1500RPM. See page 16 for details on torque calculations.

<sup>2)</sup> Maximum momentary torque for emergency stops or heavy shock load. (Admissible stops per life of gearhead = 1,000 stops maximum.)

<sup>3)</sup> For additional motor shaft sizes or smaller inertia values, please visit [configurator.stober.com](http://configurator.stober.com)

\* ME = Motor Adapter L = Large Input