

# F Series: OFFSET – Versatile Outputs

## F Features

- 4.3:1 to 552:1 ratios (higher ratios available. Contact STÖBER.)
- Quiet running (<53dB(A))
- Reduced backlash option for increased precision
- Mounting flexibility to fit the application
- Adaptability: shafts available in metric or imperial, carbon or stainless steel to meet your requirements
- Optional food and corrosion resistant package
- Dual seals for extreme duty applications
- Error free motor mounting and quick changeover with toleranced pilot on motor plate
- Magnetic oil filtration to remove contaminants to prevent breakdowns
- Build and ship in one day
- Assembled in the USA

*Compact size and flexibility make F Series gear drives a popular choice for applications that require high performance, efficiency, and durability. F Series gear drives are available with a wide selection of configurations to match almost any mounting requirement. Every gearbox is made to order. STÖBER will custom whatever you need to fit your application. Contact us today to learn more.*

**SHIPS in  
1 DAY!**  
NO EXPEDITE FEE FOR 24  
HOUR SERVICE

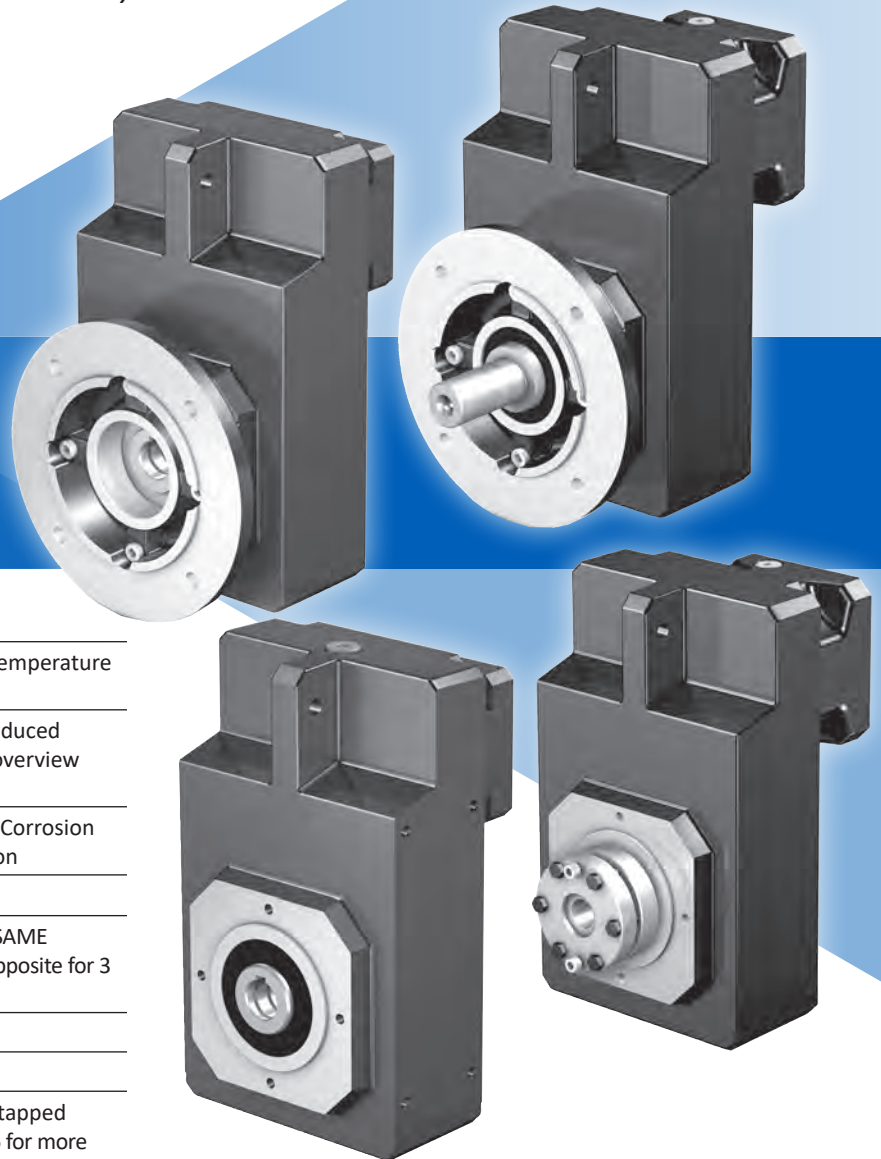

## General Specifications

<b>Ambient Temperature</b>	0°C to +40°C (104°F) [Unit temperature <80°C Max]
<b>Backlash</b>	≤10 standard arcmins, ≤6 reduced arcmins (see performance overview chart, (page 112))
<b>Coating</b>	Standard Black (RAL-9005), Corrosion Resistant option, Food option
<b>Degree of Protection</b>	IP65
<b>Direction of Rotation</b>	Input and output rotate the SAME direction got 2 stage units, opposite for 3 stage units (see page 112)
<b>Efficiency</b>	2 stage 97%; 3 stage 96%
<b>Input RPM</b>	Up to 6,000 RPM
<b>Installation</b>	Requires 10.9 fasteners for tapped holes housing. See page 306 for more information
<b>Lubrication</b>	Lubricated for life - standard Mobil 600XP200, option food grade Mobil SHC CIBUS 220
<b>Mounting Position</b>	Must be specified, see page 112
<b>Warranty</b>	5 Year Limited (2 Years on normal wear items: bearings, seals, etc.)

### Benefits of NEW ME Motor Adapters

- Higher torques
- Higher input speeds
- More compact with square coupling housing
- More clamp ring options, so less need for adapter bushings
- Clamp ring with roll pin







# Overview



## Selection Options At-a-Glance

Using the **Selection Data** table later in this section, select the F Series Gearhead with the appropriate performance and design options tailored to your motor choice and exact application requirements. Use the part number guide below as a reference to build a part number for the complete gearhead assembly.

**Part Number Examples:** 1 2 3 4 5 6 7 8 9  
F 1 0 2 V F 0043 ME10 B EL1 \*

Design Option	Part Number Code	Description
<b>1 Series</b>	<b>F</b>	Offset inline helical
<b>2 Size</b>	<b>1 2 3 4 6</b>	5 sizes of gearhead
<b>3 Generation</b>	<b>0</b>	Version of gearhead
<b>4 # of Stages</b>	<b>2</b> <b>3</b>	Two stage for ratios <150:1 Three stage >150:1
<b>5 Output</b>	 <b>V</b>	Shaft output (only available with housing option "F"; not available with food or corrosion resistant duty)
	 <b>A</b>	Hollow output (available imperial or metric, stainless steel)
	 <b>W</b>	Single or double wobble-free bushing (If single, specify side 5 or 6 only)
	 <b>S</b>	Shrink ring
<b>6 Housing</b>	 <b>F</b>	Round output flange
	 <b>G</b>	Pitch Circle Diameter (PCD) tapped holes
	 <b>NG</b>	Foot mounting (with tapped holes for side mounting)
<b>7 Ratio</b>	<b>0043</b>	Ratios range from 4.3:1 to 552:1 (0043=4.3:1; 0063=6.3:1; 5520=520:1)
<b>8 Motor Adapter</b>	<b>ME10 – ME40</b>	4 input sizes (see also motor mounting plate option)
<b>9 Options</b>	<b>B</b>	Add when ordering Corrosion Resistant Duty
	<b>F</b>	Add when ordering Food Duty
<b>* Mounting Position</b>	<b>EL1 EL2 EL3 EL4</b> <b>EL5 EL6</b>	Required special instruction for all units, see page 112

F Series: OFFSET – Versatile Outputs

### Options

#### ME Adapter Option

- MSS1 Seal – special input seal for longer life. Contact factory for this option.
- Peak Torque Booster – pinion securing element for shock loads, increasing peak torque up to 80%.

#### Lubrication Options

- Food grade or synthetic optionally available. Contact factory for this option.

#### Integrated Safety Brake

- ServoStop – provides dynamic braking during power failures or emergency stops in hazardous situations. Contact factory for this option.

#### Coating Option

- Corrosion Resistant Duty (**B** special option)
  - Food Duty (**F** special option)
- Food and Corrosion Resistant units are lubricated for life with double output seals (where possible), stainless output shaft, bore, or bushing, and heat cured paint.

#### ATEX

- ATmosphere EXplosible – rated for explosive environments. Contact factory for this option and allow additional time for delivery.

# F Series: OFFSET – Versatile Outputs

## F Series Performance Overview

F Series performance is dependent on several factors including duty cycle, bearing design, gearhead size and stage configuration, among others. Use the chart below for preliminary evaluation, then use the following performance chart and selection information on the following pages for specific performance sizing and selection.

Size/Generation			F10	F20		F30		F40		F60	
# of Stages			2	2	3	2	3	2	3	2	3
Acceleration Torque	$M_{2BMAX}$	Nm	120	270		450		700		1100	
Output Torque Nom.	$M_{2N}$	Nm	120	240		400		700		1100	
Torsional Stiffness	$C_2$	Nm/arcmin	<7.7	<17.9	<17.9	<21.8	<21.8	<38.7	<38.7	<77.4	<77.4
Torsional Backlash <sup>1)</sup> $\Delta\phi$	arcmin	Standard	≤11	≤11	≤11	≤11	≤11	≤10	≤10	≤10	≤10
		Reduced	≤6	≤6	≤7	≤6	≤7	≤5	≤6	≤5	≤6
Input Speed Max. $n_{1MAX}$	Continuous	EL1,2,3,4	4000	4000	4000	4000	4000	3700	3800	3500	3500
		EL5,6	4000	3900	3900	3900	3900	3500	3500	3200	3200
	Cyclic		7000	6500	6500	6500	6500	6000	6000	5500	5500
Efficiency (@nom torque)		%	97	97	96	97	96	97	96	97	96
Weight		kg	17.2	23.1	29.0	30.4	33.1	38.1	41.2	74.7	80.2
		lbs	38	51	64	67	73	84	91	165	177
Noise <sup>2)</sup>		dB(A)	≤55	≤53		≤53		≤53		≤61	
Size/Generation/# of Stage			F102	F202/F203		F302/F303		F402/F403		F602/F603	
Axial Load Max. <sup>3)</sup> $F_{2AMAX}$	Solid Shaft	N	1100	1400		1900		2350		3100	
		lbs	247	351		427		528		697	
	Hollow Bore	N	900	1200		1350		1900		2200	
		lbs	203	270		304		428		495	
Tilting Moment Max. <sup>3)</sup> $M_{2KMAX}$	Solid Shaft	Nm	260	400		600		800		1200	
		in.lbs	2301	3540		5310		7080		10,620	
	Hollow Bore	Nm	175	250		375		550		800	
		in.lbs	1549	2213		3319		4858		7080	

<sup>1)</sup> Tested at 1.5% of nominal torque and recorded on the output side of the gearhead. For lower backlash, contact STÖBER technical support.

<sup>2)</sup> Measurement at one (1) meter distance with input speed ( $n_1$ ) of 2000 RPM.  
To calculate torque at higher input speeds, contact the factory.

<sup>3)</sup> Rating based on output speed ( $n_2$ ) of 20 RPM. For values at other speeds see page 115

## F Series Direction of Rotation

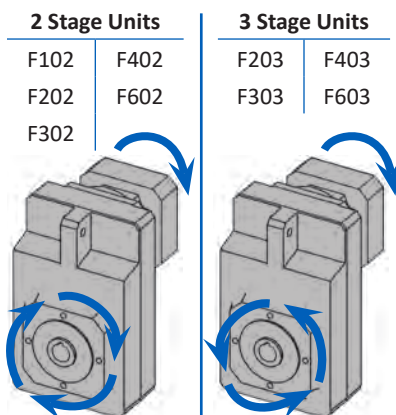

## F Series Mounting Position Options

When ordering, the Mounting Position **MUST BE SPECIFIED** using one of the Mounting Position order codes below.

Note: the code relates to the unit's orientation side that faces down. For example, EL1 has side 1 facing down, EL2 has side 2 facing down, etc.

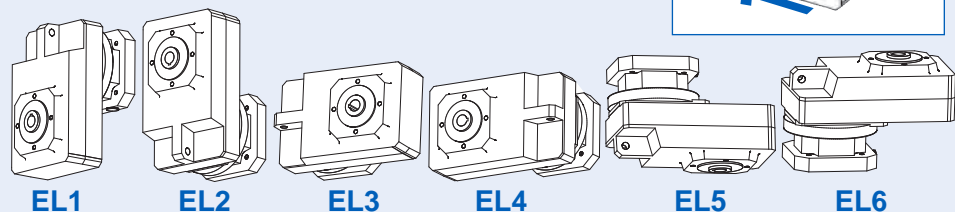



# Overview

## F Series Motor Mounting Plate Option (Motor information required with Motor Adapter option)

STÖBER Servo Gearheads fit the motor of your choice with the appropriate motor mounting plate assembled between the motor and the gearhead.

**NOTE: When ordering a gearhead:**

- Specify the motor manufacturer and part number
- Provide the motor drawing with dimensions, or specify the motor mounting dimensions (per the list shown at right)

For a precise dimension on a specific motor, or for general assistance, we recommend you contact STÖBER Technical Support.

**Customer Required Dimensions for Properly Sized Motor Mounting Plate**

d2	Motor Shaft Diameter (If an adapter bushing is required it will be supplied with the motor plate.)
b6	Pilot Diameter
e6	Bolt Circle Diameter
s6	Bolt Diameter
I5	Motor Shaft Length
f6	Pilot Length
a6	Square Flange (Optional – motor plate will typically be made to match this dimension.)

Motor Mounting Plate Dimensions — mm(Gearhead Part Number Specific)	ME10	ME20	ME30	ME40
Maximum Allowed Motor Shaft Dia. d2	19	32	38	48
Minimum Allowed Motor Plate Thickness c*	21	24	26	35

\* Note that the c motor plate thickness is determined by the motor shaft length. The minimum motor plate thickness is the value listed.

### F Series Motor Mounting Plate Access Hole

Access to the clamping screw for the motor coupling is located on the 270° side of the motor mounting plate at the location shown. If necessary, the motor mounting plate can be rotated in the field, if a 0°, 90° or 180° orientation for the access hole is desirable.

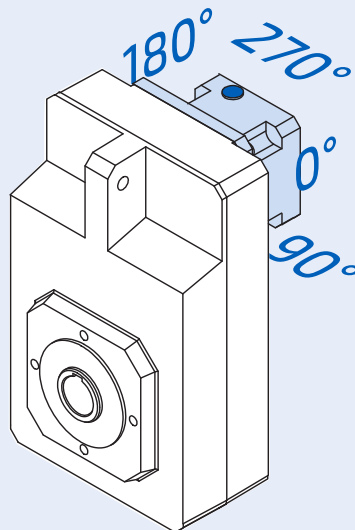

F Series: OFFSET – Versatile Outputs

# F Series: OFFSET – Versatile Outputs

## F Series Output Options

Diameters in **BOLD BLUE** are configurations readily available from inventory. Contact STÖBER for delivery on other output sizes.

			F1	F2	F3	F4	F6
Solid Shaft	Carbon Steel	Inches	<b>1</b>	<b>1-1/4</b>	<b>1-3/8</b>	<b>1-5/8</b>	<b>2-1/8</b>
		Metric	25	—	—	40	—
	Stainless Steel*	Inches	—	—	—	—	—
		Metric	—	—	—	—	—
Hollow Bore	Carbon Steel	Inches	<b>3/4</b>	<b>1</b>	<b>1-1/4</b>	1-7/16 <b>1-1/2</b>	<b>2</b>
		Metric	20	25	30	40	50
	Stainless Steel*	Inches	—	—	<b>1-1/4</b>	<b>1-1/2</b>	—
		Metric	—	—	—	—	—
Wobble Free Bushing (Single & Double Bushings**)	Stainless Steel*	Inches	<b>3/4</b>	1 <b>1-3/16</b>	1 1-3/16 <b>1-1/4</b> 1-7/16 <b>1-1/2</b>	<b>1-7/16</b> <b>1-1/2</b>	<b>1-7/16</b> <b>1-1/2</b> 1-15/16 <b>2</b>
		Metric	20	—	—	40	—
Shrink Ring	Carbon Steel	Metric	<b>20</b>	<b>25</b>	<b>30</b>	<b>40</b>	—

\* Stainless steel options are ideal for food and corrosion resistant, harsh washdown environments.

\*\* Double bushings only available with two stage units

\*\*\* Double bushing only

## Permissible Motor Tilting Torque

The permissible tilting torque of the motor attached to the gear unit is a result of the static and dynamic load “F” from the motor weight, mass acceleration, and vibration multiplied by the distance from the center of gravity “l<sub>S</sub>” of the motor.

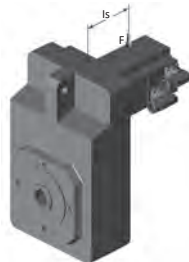

$$M_{1K} = F \times l_S \leq M_{1K}$$

M <sub>1K</sub>	ME10	ME20	ME30	ME40	ME50
Nm	25	60	125	250	250

## Permissible Output Shaft Load and Tilting Moments\*

Unit	V Solid Shaft Output				A, S, W Hollow Output <sup>1)</sup>		
	Z <sub>2</sub>	F <sub>2A</sub>	F <sub>2R</sub>	M <sub>2K</sub>	Z <sub>2</sub>	F <sub>2A</sub>	M <sub>2K</sub>
	mm	N	N	Nm	mm	N	Nm
<b>F1</b>	35	1100	4200	260	30	900	175
<b>F2</b>	41	1400	5400	400	33	1200	250
<b>F3</b>	43	1900	7500	600	33	1350	375
<b>F4</b>	44	2350	9250	800	39	1900	550
<b>F6</b>	44	3100	12,500	1200	45	2200	800

\* Refer to illustration and definitions below.

<sup>1)</sup> Values shown for “W” Style are for double bushings. For single bushings use value M<sub>2K</sub> x 0.5 and F<sub>2A</sub> x 0.5



# Overview

## Overhung Load Calculations

Pulling forces or overhung load of pulleys, sheaves, sprockets, etc. on the reducer output shaft must not exceed the allowable limits shown in the load/life/speed calculations below.

Note: Overhung load is measured at the center of the shaft extension. No overhung load is encountered when a reducer is flange mounted and/or coupling connected to another unit. However, the shafts of all components must be accurately aligned and secured to prevent pre-loading of the bearings and premature bearing failure.

Use the following formula to determine actual overhung load for a given drive..

$$\text{Imperial OHL (lbs)} = \frac{126,000 \times \text{HP} \times K}{D \times n}$$

$$\text{Metric OHL (N)} = \frac{19,100 \times \text{kW} \times K}{D \times n}$$

Where:

<b>OHL</b>	Overhung load (N or lbs)
<b>HP</b>	Horsepower
<b>kW</b>	Transmitted Kilowatt
<b>D</b>	Pitch Diameter (inches or meters) of Sprocket, Gear, Sheave, Pulley, etc.
<b>n</b>	Maximum Shaft RPM
<b>K</b>	1.00 Single Chain Drive; 1.25 Timing Belt Drive; 1.25 Spur or Helical Gear Drive; 1.50 V-Belt Drive; 2.50 Flat Belt Drive

## F Series Load/Life/Speed Calculations

The permissible load and tilting moment values are based on an output speed of 20 RPM. For higher speeds the following applies, where  $n_2$  is the desired speed:

$$F_{2axN} = \frac{F_{2ax20}}{\sqrt[3]{\frac{n_{2m^*}}{20 \text{ rpm}}}} \quad F_{2radN} = \frac{F_{2rad20}}{\sqrt[3]{\frac{n_{2m^*}}{20 \text{ rpm}}}} \quad M_{2kN} = \frac{M_{2k20}}{\sqrt[3]{\frac{n_{2m^*}}{20 \text{ rpm}}}}$$

The application output tilting moment should be determined by the following formula:

$$M_{2k^*} = \frac{2 \cdot F_{2ax^*} \cdot Y_2 + F_{2rad^*} \cdot (X_2 + Z_2)}{1000} \leq M_{2kN}$$

$$F_{2rad^*} \leq F_{2radN} \quad F_{2ax^*} \leq F_{2axN}$$

Where:

<b>Z<sub>2</sub></b>	Distance of Shaft Shoulder to Center of Output Bearing
<b>n<sub>2</sub></b>	Actual Average Output Speed
<b>X<sub>2</sub></b>	Distance of the Shaft Shoulder to the Force Application Point
<b>Y<sub>2</sub></b>	Distance of the Shaft Axis to the Axial Force Application Point
<b>F<sub>2ax</sub><sup>*</sup></b>	Actual Axial Force at Gear Unit Output
<b>F<sub>2ax100</sub></b>	Permitted Axial Force
<b>F<sub>2rad100</sub></b>	Permitted Radial Force ≤100RPM
<b>F<sub>2rad,acc</sub></b>	Radial Acceleration Force
<b>F<sub>2rad,acc</sub><sup>*</sup></b>	Radial Acceleration Force at Gear Unit Output
<b>M<sub>2K100</sub></b>	Permitted Tilting Torque ≤100RPM
<b>M<sub>2K,acc</sub></b>	Permitted Acceleration Tilting Torque
<b>M<sub>2k,acc</sub><sup>*</sup></b>	Permitted Acceleration Tilting Torque at Gear Unit Output
<b>C<sub>2K</sub></b>	Tilting Stiffness

All formulas shown are based on METRIC values

Upper case letters are permissible values. Lower case letters are for existing values.

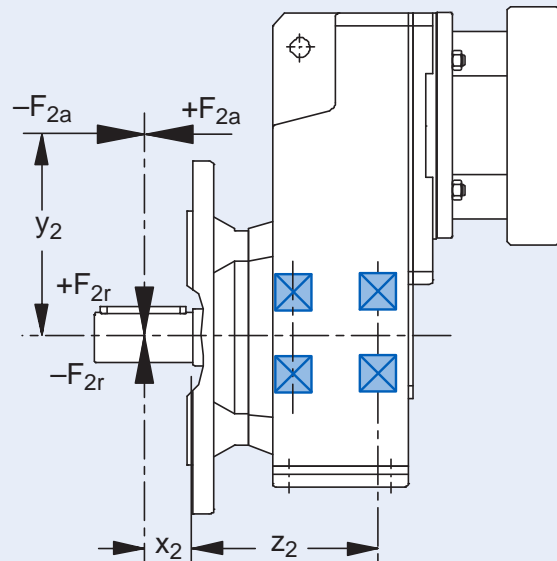

F Series: OFFSET – Versatile Outputs



# F Series: OFFSET – Versatile Outputs

Reducer Ratio (i)		Output Torque			Backlash <sup>3)</sup> $\Delta\phi_2$	Part Number (Gearhead + Input)	Max. Input Speed RPM (n1)			Motor Shaft Max $\phi$ $d_{MW}$	Input Inertia $J_1$	Tors. Stiffness $C_2$
		Nom. <sup>1)</sup> $M_{2N}$	Accel. $M_{2ACC}$	Peak <sup>2)</sup> $M_{2NOT}$			Continuous		Cyclic			
Nom.	Exact	Nm	Nm	Nm	arcmin		EL 1,2,3,4	EL 5,6	All	mm	kgcm <sup>2</sup>	Nm/ arcmin

## F1

4.308	56/13	69	100	130	11/8	F102_0043 ME10	3500	3000	6000	≤19	2.1	6.2
						F102_0043 ME20				≤24	4.0	6.4
6.462	84/13	79	110	190	11/8	F102_0065 ME10	3500	3000	6000	≤19	1.4	6.4
						F102_0065 ME20				≤24	3.3	6.5
7.156	322/45	81	110	200	11/8	F102_0072 ME10	3700	3600	6000	≤19	1.3	6.4
						F102_0072 ME20				≤24	3.2	6.5
8.948	1029/115	88	110	200	11/8	F102_0089 ME10	3700	3600	6000	≤19	1.1	6.5
						F102_0089 ME20				≤24	3.0	
10.92	273/25	94	110	200	11/8	F102_0110 ME10	4000	4000	6500	≤19	0.9	6.5
						F102_0110 ME20	3700	3700	6000	≤24	2.8	
13.59	231/17	100	110	200	11/8	F102_0135 ME10	4000	4000	6500	≤19	0.9	6.5
						F102_0135 ME20	3700	3700	6000	≤24	2.7	
18.46	1495/81	110	120	240	11/6	F102_0185 ME10	3700	3600	6000	≤19	1.0	7.7
						F102_0185 ME20				≤24	2.9	
23.08	3185/138	120	120	240	11/6	F102_0230 ME10	3700	3600	6000	≤19	0.9	7.7
						F102_0230 ME20				≤24	2.8	
28.17	169/6	120	120	240	11/6	F102_0280 ME10	4000	4000	6500	≤19	0.8	7.7
						F102_0280 ME20	3700	3700	6000	≤24	2.7	
35.05	3575/102	120	120	240	11/6	F102_0350 ME10	4000	4000	6500	≤19	0.8	7.7
						F102_0350 ME20	3700	3700	6000	≤24	2.7	
46.43	325/7	120	120	240	11/6	F102_0460 ME10	4000	4000	7000	≤19	0.7	7.7
						F102_0460 ME20	3700	3700	6000	≤24	2.6	
55.97	2015/36	120	120	240	11/6	F102_0560 ME10	4000	4000	7000	≤19	0.7	7.7
						F102_0560 ME20	3700	3700	6000	≤24	2.6	
70.06	1261/18	120	120	240	11/6	F102_0700 ME10	4000	4000	7000	≤19	0.7	7.7
						F102_0700 ME20	3700	3700	6000	≤24	2.6	
93.63	7865/84	120	120	240	11/6	F102_0940 ME10	4000	4000	7000	≤19	0.6	7.7
111.9	2015/18	120	120	240	11/6	F102_1120 ME10	4000	4000	7000	≤19	0.6	7.7
139.8	559/4	120	120	240	11/6	F102_1400 ME10	4000	4000	7000	≤19	0.6	7.7

<sup>1)</sup> Maximum torque for continuous input 1500 RPM - horizontal output position.

<sup>2)</sup> Maximum momentary torque for emergency stops or heavy shock load. (Admissible stops per life of gearhead = 1,000 stops maximum.)

<sup>3)</sup> Backlash shown standard/reduced

# Selection Data



Reducer Ratio (i)		Output Torque			Backlash <sup>3)</sup> $\Delta\Phi_2$	Part Number (Gearhead + Input)	Max. Input Speed RPM (n1)			Motor Shaft Max $\Phi$ $d_{MW}$	Input Inertia $J_1$	Tors. Stiffness $C_2$
		Nom. <sup>1)</sup> $M_{2N}$	Accel. $M_{2acc}$	Peak <sup>2)</sup> $M_{2NOT}$			Continuous		Cyclic			
Nom.	Exact	Nm	Nm	Nm	arcmin		EL 1,2,3,4	EL 5,6	All	mm	kgcm <sup>2</sup>	Nm/ arcmin

## F2 (continued next page)

4.680	2616/559	110	110	140	11/8	F202_0047 ME10	3100	2600	5000	$\leq 19$	4.7	14.0
		140	210	340		F202_0047 ME20				$\leq 32$	8.1	15.0
						F202_0047 ME30				$\leq 38$	13.0	
5.552	5341/962	150	210	400	11/8	F202_0056 ME20	3100	2600	5000	$\leq 32$	7.1	15.0
						F202_0056 ME30				$\leq 38$	12.0	
7.167	5777/806	150	170	210	11/8	F202_0072 ME10	3600	3100	6000	$\leq 19$	2.6	15.0
		160	210	400		F202_0072 ME20				$\leq 32$	6.0	
						F202_0072 ME30	3500	5000	$\leq 38$	11.0		
9.006	3161/351	160	210	260	11/8	F202_0090 ME10	3600	3100	6000	$\leq 19$	1.9	15.0
		170		400		F202_0090 ME20				$\leq 32$	5.3	
							F202_0090 ME30	3500	5000	$\leq 38$	11.0	
10.80	7303/676	170	210	310	11/8	F202_0110 ME10	3800	3500	6000	$\leq 19$	1.6	15.0
		190		400		F202_0110 ME20	3700			$\leq 32$	5.0	
							F202_0110 ME30	3500	5000	$\leq 38$	10.0	
13.63	109/8	180	210	400	11/8	F202_0135 ME10	3800	3500	6000	$\leq 19$	1.3	15.0
		200				F202_0135 ME20	3700			$\leq 32$	4.7	
								F202_0135 ME30	3500	5000	$\leq 38$	
18.65	6360/341	220	270	480	11/6	F202_0185 ME10	3600	3100	6000	$\leq 19$	1.6	18.0
						F202_0185 ME20				$\leq 32$	5.0	
						F202_0185 ME30	3500	5000	$\leq 38$	10.0		
23.43	2320/99	240	270	480	11/6	F202_0230 ME10	3600	3100	6000	$\leq 19$	1.3	18.0
						F202_0230 ME20				$\leq 32$	4.7	
						F202_0230 ME30	3500	5000	$\leq 38$	10.0		
28.11	4020/143	240	270	480	11/6	F202_0280 ME10	3800	3500	6000	$\leq 19$	1.1	18.0
						F202_0280 ME20				3700	$\leq 32$	
						F202_0280 ME30	3500	5000	$\leq 38$	9.9		
35.46	390/11	240	270	480	11/6	F202_0350 ME10	3800	3500	6000	$\leq 19$	1.0	18.0
						F202_0350 ME20				3700	$\leq 32$	
						F202_0350 ME30	3500	5000	$\leq 38$	9.7		
47.05	1035/22	240	270	480	11/6	F202_0470 ME10	4000	3900	6500	$\leq 19$	0.9	18.0
						F202_0470 ME20	3700	3700	6000	$\leq 32$	4.3	
						F202_0470 ME30	3500	3500	5000	$\leq 38$	9.6	

F Series: OFFSET – Versatile Outputs

<sup>1)</sup> Maximum torque for continuous input 1500 RPM - horizontal output position.

<sup>2)</sup> Maximum momentary torque for emergency stops or heavy shock load. (Admissible stops per life of gearhead = 1,000 stops maximum.)

<sup>3)</sup> Backlash shown standard/reduced



## F Series: OFFSET – Versatile Outputs

Reducer Ratio (i)		Output Torque			Backlash <sup>3)</sup> $\Delta\phi_2$	Part Number (Gearhead + Input)	Max. Input Speed RPM (n1)			Motor Shaft Max Ø $d_{MW}$	Input Inertia $J_1$	Tors. Stiffness $C_2$
		Nom. <sup>1)</sup> $M_{2N}$	Accel. $M_{2ACC}$	Peak <sup>2)</sup> $M_{2NOT}$			Continuous		Cyclic			
Nom.	Exact	Nm	Nm	Nm	arcmin	EL 1,2,3,4	EL 5,6	All	mm	kgcm <sup>2</sup>	Nm/ arcmin	

### F2 (continued from previous page)

56.73	624/11	240	270	480	11/6	<b>F202_0570 ME10</b>	4000	3900	6500	≤19	0.8	18.0
						<b>F202_0570 ME20</b>	3700	3700	6000	≤24	2.7	
70.13	5400/77	240	270	480	11/6	<b>F202_0700 ME10</b>	4000	3900	6500	≤19	0.8	18.0
						<b>F202_0700 ME20</b>	3700	3700	6000	≤24	2.7	
93.82	1032/11	240	270	480	11/6	<b>F202_0940 ME10</b>	4000	3900	6500	≤19	0.7	18.0
						<b>F202_0940 ME20</b>	3700	3700	6000	≤24	2.6	
112.7	1240/11	240	270	480	11/6	<b>F202_1130 ME10</b>	4000	3900	6500	≤19	0.7	18.0
140.9	1550/11	240	270	480	11/6	<b>F202_1410 ME10</b>	4000	3900	6500	≤19	0.6	18.0
184.3	16215/88	240	270	480	11/7	<b>F203_1840 ME10</b>	4000	3900	6500	≤19	0.7	18.0
222.2	2444/11	240	270	480	11/7	<b>F203_2220 ME10</b>	4000	3900	6500	≤19	0.7	18.0
274.7	21150/77	240	270	480	11/7	<b>F203_2750 ME10</b>	4000	3900	6500	≤19	0.7	18.0
367.5	4042/11	240	270	480	11/7	<b>F203_3670 ME10</b>	4000	3900	6500	≤19	0.7	18.0
441.5	14570/33	240	270	480	11/7	<b>F203_4420 ME10</b>	4000	3900	6500	≤19	0.7	18.0
551.9	36425/66	240	270	480	11/7	<b>F203_5520 ME10</b>	4000	3900	6500	≤19	0.7	18.0

<sup>1)</sup> Maximum torque for continuous input 1500 RPM - horizontal output position.

<sup>2)</sup> Maximum momentary torque for emergency stops or heavy shock load. (Admissible stops per life of gearhead = 1,000 stops maximum.)

<sup>3)</sup> Backlash shown standard/reduced

# Selection Data



Reducer Ratio (i)		Output Torque			Backlash <sup>3)</sup> $\Delta\phi_2$	Part Number (Gearhead + Input)	Max. Input Speed RPM (n1)			Motor Shaft Max $\phi$ $d_{MW}$	Input Inertia $J_1$	Tors. Stiffness $C_2$
		Nom. <sup>1)</sup> $M_{2N}$	Accel. $M_{2acc}$	Peak <sup>2)</sup> $M_{2NOT}$			Continuous		Cyclic			
Nom.	Exact	Nm	Nm	Nm	arcmin		EL 1,2,3,4	EL 5,6	All	mm	kgcm <sup>2</sup>	Nm/ arcmin

## F3 (continued next page)

4.644	4992/1075	230 230	270	340	11/8	F302_0046 ME20	3000	2600	4500	$\leq 32$	12.0	20.0
			350	650		F302_0046 ME30				$\leq 38$	18.0	
5.720	143/25	250	330	420	11/8	F302_0057 ME20	3000	2600	4500	$\leq 32$	9.7	20.0
						F302_0057 ME30				$\leq 38$	15.0	
7.172	208/29	270	350	520	11/8	F302_0072 ME20	3500	3100	5000	$\leq 32$	7.9	20.0
						F302_0072 ME30				$\leq 38$	13.0	
8.986	5616/625	180 290	210 350	260 650	11/8	F302_0090 ME10	3500	3100	5000	$\leq 19$	3.3	20.0
						F302_0090 ME20				$\leq 32$	6.7	
						F302_0090 ME30				$\leq 38$	12.0	
10.79	1456/135	190 310	250 350	310 650	11/8	F302_0110 ME10	3700	3500	5500	$\leq 19$	2.5	20.0
						F302_0110 ME20				$\leq 32$	5.9	
						F302_0110 ME30	3500	5000	$\leq 38$	11.0		
13.38	7696/575	200 330	310 350	390 650	11/8	F302_0135 ME10	3700	3500	5500	$\leq 19$	1.9	20.0
						F302_0135 ME20				$\leq 32$	5.3	
						F302_0135 ME30	3500	5000	$\leq 38$	11.0		
18.77	4900/261	370	450	800	11/6	F302_0190 ME20	3500	3100	5000	$\leq 32$	5.9	22.0
						F302_0190 ME30				$\leq 38$	11.0	
23.52	588/25	400	450	680	11/6	F302_0240 ME10	3500	3100	5000	$\leq 19$	2.0	22.0
				800		F302_0240 ME20				$\leq 32$	5.4	
				F302_0240 ME30		$\leq 38$				11.0		
28.23	6860/243	400	450	800	11/6	F302_0280 ME10	3700	3500	5500	$\leq 19$	1.7	22.0
						F302_0280 ME20				$\leq 32$	5.1	
						F302_0280 ME30	3500	5000	$\leq 38$	10.0		
35.03	7252/207	400	450	800	11/6	F302_0350 ME10	3700	3500	5500	$\leq 19$	1.4	22.0
						F302_0350 ME20				$\leq 32$	4.8	
						F302_0350 ME30	3500	5000	$\leq 38$	10.0		
47.19	1274/27	400	450	800	11/6	F302_0470 ME10	4000	3900	6500	$\leq 19$	1.1	22.0
						F302_0470 ME20	3700	3700	6000	$\leq 32$	4.5	
						F302_0470 ME30	3500	3500	5000	$\leq 38$	9.8	
56.49	4067/72	400	450	800	11/6	F302_0560 ME10	4000	3900	6500	$\leq 19$	1.0	22.0
						F302_0560 ME20	3700	3700	6000	$\leq 32$	4.4	
						F302_0560 ME30	3500	3500	5000	$\leq 38$	9.7	

F Series: OFFSET – Versatile Outputs

<sup>1)</sup> Maximum torque for continuous input 1500 RPM - horizontal output position.

<sup>2)</sup> Maximum momentary torque for emergency stops or heavy shock load. (Admissible stops per life of gearhead = 1,000 stops maximum.)

<sup>3)</sup> Backlash shown standard/reduced

# F Series: OFFSET – Versatile Outputs

Reducer Ratio (i)		Output Torque			Backlash <sup>3)</sup> $\Delta\phi_2$	Part Number (Gearhead + Input)	Max. Input Speed RPM (n1)			Motor Shaft Max $\phi$ $d_{MW}$	Input Inertia $J_1$	Tors. Stiffness $C_2$
		Nom. <sup>1)</sup> $M_{2N}$	Accel. $M_{2acc}$	Peak <sup>2)</sup> $M_{2NOT}$			Continuous		Cyclic			
Nom.	Exact	Nm	Nm	Nm	arcmin		EL 1,2,3,4	EL 5,6	All	mm	kgcm <sup>2</sup>	Nm/ arcmin

## F3 (continued from previous page)

70.36	2744/39	400	450	800	11/6	<b>F302_0700 ME10</b>	4000	3900	6500	≤19	0.9	22.0
						<b>F302_0700 ME20</b>	3700	3700	6000	≤24	2.8	
93.64	4214/45	400	450	800	11/6	<b>F302_0940 ME10</b>	4000	3900	6500	≤19	0.8	22.0
						<b>F302_0940 ME20</b>	3700	3700	6000	≤24	2.7	
112.8	3724/33	400	450	800	11/6	<b>F302_1130 ME10</b>	4000	3900	6500	≤19	0.7	22.0
						<b>F302_1130 ME20</b>	3700	3700	6000	≤24	2.6	
140.6	7595/54	400	450	620	11/6	<b>F302_1410 ME10</b>	4000	3900	6500	≤19	0.7	22.0
182.4	73892/405	400	450	800	11/7	<b>F303_1820 ME20</b>	3700	3700	6000	≤24	2.7	22.0
184.8	29939/162	400	450	800	11/7	<b>F303_1850 ME10</b>	4000	3900	6500	≤19	0.7	22.0
218.4	117943/540	400	450	800	11/7	<b>F303_2180 ME20</b>	3700	3700	6000	≤24	2.7	22.0
221.2	191149/864	400	450	800	11/7	<b>F303_2210 ME10</b>	4000	3900	6500	≤19	0.7	22.0
272.1	159152/585	400	450	800	11/7	<b>F303_2720 ME20</b>	3700	3700	6000	≤24	2.7	22.0
275.6	32242/117	400	450	800	11/7	<b>F303_2760 ME10</b>	4000	3900	6500	≤19	0.7	22.0
362.1	244412/675	400	450	800	11/7	<b>F303_3620 ME20</b>	3700	3700	6000	≤24	2.7	22.0
366.8	99029/270	400	450	800	11/7	<b>F303_3670 ME10</b>	4000	3900	6500	≤19	0.7	22.0
442.0	43757/99	400	450	800	11/7	<b>F303_4420 ME10</b>	4000	3900	6500	≤19	0.7	22.0
550.9	356965/648	400	450	620	11/7	<b>F303_5510 ME10</b>	4000	3900	6500	≤19	0.7	22.0

<sup>1)</sup> Maximum torque for continuous input 1500 RPM - horizontal output position.

<sup>2)</sup> Maximum momentary torque for emergency stops or heavy shock load. (Admissible stops per life of gearhead = 1,000 stops maximum.)

<sup>3)</sup> Backlash shown standard/reduced

# Selection Data



Reducer Ratio (i)		Output Torque			Backlash <sup>3)</sup> $\Delta\phi_2$	Part Number (Gearhead + Input)	Max. Input Speed RPM (n1)			Motor Shaft Max $\phi$ $d_{MW}$	Input Inertia $J_1$	Tors. Stiffness $C_2$
		Nom. <sup>1)</sup> $M_{2N}$	Accel. $M_{2acc}$	Peak <sup>2)</sup> $M_{2NOT}$			Continuous		Cyclic			
Nom.	Exact	Nm	Nm	Nm	arcmin		EL 1,2,3,4	EL 5,6	All	mm	kgcm <sup>2</sup>	Nm/ arcmin

## F4 (continued next page)

4.678	1408/301	390	550	910	10/7	F402_0047 ME30	2700	2300	4000	$\leq 38$	24.0	38.0
						F402_0047 ME40				$\leq 48$	46.0	
5.813	3784/651	410	550	1100	10/7	F402_0058 ME30	2700	2300	4000	$\leq 38$	20.0	38.0
						F402_0058 ME40				$\leq 48$	42.0	
7.202	605/84	420	420	520	10/7	F402_0072 ME20	3200	2800	4800	$\leq 32$	11.0	38.0
		450	550	1100		F402_0072 ME30				$\leq 38$	16.0	
						F402_0072 ME40	3000	4500	$\leq 48$	38.0		
8.980	440/49	470	520	650	10/7	F402_0090 ME20	3200	2800	4800	$\leq 32$	8.8	38.0
		480	550	1100		F402_0090 ME30				$\leq 38$	14.0	
						F402_0090 ME40	3000	4500	$\leq 48$	36.0		
10.83	682/63	490	550	790	10/7	F402_0110 ME20	3500	3100	5500	$\leq 32$	7.5	38.0
		510		1100		F402_0110 ME30				$\leq 38$	13.0	
		F402_0110 ME40	3000	3000		4500	$\leq 48$	35.0				
13.57	5984/441	540	550	930	10/7	F402_0135 ME20	3500	3100	5500	$\leq 32$	6.4	38.0
		550		1100		F402_0135 ME30				$\leq 38$	12.0	
			F402_0135 ME40			3000	3000	4500	$\leq 48$	34.0		
18.62	3575/192	610	700	1350	10/5	F402_0185 ME20	3200	2800	4800	$\leq 32$	7.3	39.0
				1400		F402_0185 ME30				$\leq 38$	13.0	
		F402_0185 ME40	3000	4500		$\leq 48$	35.0					
23.21	325/14	660	700	1400	10/5	F402_0230 ME20	3200	2800	4800	$\leq 32$	6.4	39.0
						F402_0230 ME30				$\leq 38$	12.0	
		F402_0230 ME40	3000	4500		$\leq 48$	34.0					
27.99	2015/72	700	700	1400	10/5	F402_0280 ME20	3500	3100	5500	$\leq 32$	5.9	39.0
						F402_0280 ME30				$\leq 38$	11.0	
		F402_0280 ME40	3000	3000		4500	$\leq 48$	33.0				
35.08	2210/63	700	700	1400	10/5	F402_0350 ME20	3500	3100	5500	$\leq 32$	5.3	39.0
						F402_0350 ME30				$\leq 38$	11.0	
		F402_0350 ME40	3000	3000		4500	$\leq 48$	33.0				
46.94	845/18	700	700	1400	10/5	F402_0470 ME20	3700	3500	6000	$\leq 32$	4.9	39.0
						F402_0470 ME30				3500	5000	
		F402_0470 ME40	3000	3000		4500	$\leq 48$	32.0				

F Series: OFFSET – Versatile Outputs

<sup>1)</sup> Maximum torque for continuous input 1500 RPM - horizontal output position.

<sup>2)</sup> Maximum momentary torque for emergency stops or heavy shock load. (Admissible stops per life of gearhead = 1,000 stops maximum.)

<sup>3)</sup> Backlash shown standard/reduced

# F Series: OFFSET – Versatile Outputs

Reducer Ratio (i)		Output Torque			Backlash <sup>3)</sup> $\Delta\phi_2$	Part Number (Gearhead + Input)	Max. Input Speed RPM (n1)			Motor Shaft Max $\phi$ $d_{MW}$	Input Inertia $J_1$	Tors. Stiffness $C_2$
		Nom. <sup>1)</sup> $M_{2N}$	Accel. $M_{2acc}$	Peak <sup>2)</sup> $M_{2NOT}$			Continuous		Cyclic			
Nom.	Exact	Nm	Nm	Nm	arcmin	EL 1,2,3,4	EL 5,6	All	mm	kgcm <sup>2</sup>	Nm/ arcmin	

## F4 (continued from previous page)

55.97	2015/36	700	700	1400	10/5	F402_0560 ME20	3700	3500	6000	$\leq 32$	4.7	39.0
						F402_0560 ME30	3500		5000	$\leq 38$	10.0	
70.06	1261/18	700	700	1400	10/5	F402_0700 ME20	3700	3500	6000	$\leq 32$	4.5	39.0
						F402_0700 ME30	3500		5000	$\leq 38$	9.8	
93.33	280/3	700	700	1400	10/5	F402_0930 ME20	3700	3500	6000	$\leq 24$	2.8	39.0
112.3	1235/11	700	700	1400	10/5	F402_1120 ME20	3700	3500	6000	$\leq 24$	2.7	39.0
139.8	559/4	700	700	1400	10/5	F402_1400 ME20	3700	3500	6000	$\leq 24$	2.7	39.0
181.5	4901/27	700	700	1400	10/6	F403_1820 ME20	3700	3500	6000	$\leq 24$	2.7	39.0
183.9	39715/216	700	700	1180	10/6	F403_1840 ME10	3800	3500	6000	$\leq 19$	0.7	39.0
216.4	11687/54	700	700	1400	10/6	F403_2160 ME20	3700	3500	6000	$\leq 24$	2.7	39.0
219.2	94705/432	700	700	1400	10/6	F403_2190 ME10	3800	3500	6000	$\leq 19$	0.7	39.0
270.9	36569/135	700	700	1400	10/6	F403_2710 ME20	3700	3500	6000	$\leq 24$	2.7	39.0
274.4	59267/216	700	700	1400	10/6	F403_2740 ME10	3800	3500	6000	$\leq 19$	0.7	39.0
360.9	3248/9	700	700	1400	10/6	F403_3610 ME20	3700	3500	6000	$\leq 24$	2.7	39.0
365.6	3290/9	700	700	1400	10/6	F403_3660 ME10	3800	3500	6000	$\leq 19$	0.7	39.0
434.1	14326/33	700	700	1400	10/6	F403_4340 ME20	3700	3500	6000	$\leq 24$	2.7	39.0
439.7	58045/132	700	700	1400	10/6	F403_4400 ME10	3800	3500	6000	$\leq 19$	0.7	39.0
547.4	26273/48	700	700	1400	10/6	F403_5470 ME10	3800	3500	6000	$\leq 19$	0.7	39.0

<sup>1)</sup> Maximum torque for continuous input 1500 RPM - horizontal output position.

<sup>2)</sup> Maximum momentary torque for emergency stops or heavy shock load. (Admissible stops per life of gearhead = 1,000 stops maximum.)

<sup>3)</sup> Backlash shown standard/reduced

# Selection Data



Reducer Ratio (i)		Output Torque			Backlash <sup>3)</sup> $\Delta\phi_2$	Part Number (Gearhead + Input)	Max. Input Speed RPM (n1)			Motor Shaft Max $\phi$ $d_{MW}$	Input Inertia $J_1$	Tors. Stiffness $C_2$
		Nom. <sup>1)</sup> $M_{2N}$	Accel. $M_{2acc}$	Peak <sup>2)</sup> $M_{2NOT}$			Continuous		Cyclic			
Nom.	Exact	Nm	Nm	Nm	arcmin		EL 1,2,3,4	EL 5,6	All	mm	kgcm <sup>2</sup>	Nm/ arcmin

## F6 (continued next page)

4.546	1273/280	580	710	880	10/7	F602_0045 ME30	2500	2100	3500	$\leq 38$	46.0	69.0
		640				F602_0045 ME40				$\leq 48$	68.0	
5.673	1407/248	650	880	1100	10/7	F602_0057 ME30	2500	2100	3500	$\leq 38$	34.0	70.0
		690				F602_0057 ME40				$\leq 48$	56.0	
7.159	3551/496	700	1000	1380	10/7	F602_0072 ME30	2900	2500	4500	$\leq 38$	26.0	71.0
		740				F602_0072 ME40				$\leq 48$	48.0	
8.995	1943/216	520	520	650	10/7	F602_0090 ME20	2900	2500	4500	$\leq 32$	15.0	70.0
		760	1000	1600		F602_0090 ME30				$\leq 38$	20.0	72.0
		800				F602_0090 ME40				$\leq 48$	42.0	
10.82	2077/192	560	630	790	10/7	F602_0110 ME20	3300	2800	5000	$\leq 32$	12.0	71.0
		820	1000	1600		F602_0110 ME30				$\leq 38$	17.0	72.0
		850				F602_0110 ME40	3000	4500	$\leq 48$	39.0		
13.61	871/64	590	740	920	10/7	F602_0135 ME20	3300	2800	5000	$\leq 32$	9.4	72.0
		860	1000	1600		F602_0135 ME30				$\leq 38$	15.0	
		920				F602_0135 ME40	3000	4500	$\leq 48$	37.0		
18.52	3445/186	1020	1100	2000	10/5	F602_0185 ME30	2900	2500	4500	$\leq 38$	17.0	77.0
						F602_0185 ME40				$\leq 48$	39.0	
23.27	1885/81	1100	1100	1690	10/5	F602_0230 ME20	2900	2500	4500	$\leq 32$	9.5	77.0
				2000		F602_0230 ME30				$\leq 38$	15.0	
				F602_0230 ME40		$\leq 48$				37.0		
27.99	2015/72	1100	1100	2000	10/5	F602_0280 ME20	3300	2800	5000	$\leq 32$	8.2	77.0
						F602_0280 ME30				$\leq 38$	14.0	
						F602_0280 ME40	3000	4500	$\leq 48$	36.0		
35.21	845/24	1100	1100	2000	10/5	F602_0350 ME20	3300	2800	5000	$\leq 32$	7.0	77.0
						F602_0350 ME30				$\leq 38$	12.0	
						F602_0350 ME40	3000	4500	$\leq 48$	34.0		
46.72	1495/32	1100	1100	2000	10/5	F602_0470 ME20	3500	3200	5500	$\leq 32$	6.0	77.0
						F602_0470 ME30				5000	$\leq 38$	
						F602_0470 ME40	3000	3000	4500		$\leq 48$	
55.71	390/7	1100	1100	2000	10/5	F602_0560 ME20	3500	3200	5500	$\leq 32$	5.5	77.0
						F602_0560 ME30				5000	$\leq 38$	

F Series: OFFSET – Versatile Outputs

<sup>1)</sup> Maximum torque for continuous input 1500 RPM - horizontal output position.

<sup>2)</sup> Maximum momentary torque for emergency stops or heavy shock load. (Admissible stops per life of gearhead = 1,000 stops maximum.)

<sup>3)</sup> Backlash shown standard/reduced



# F Series: OFFSET – Versatile Outputs

Reducer Ratio (i)		Output Torque			Backlash <sup>3)</sup> $\Delta\phi_2$	Part Number (Gearhead + Input)	Max. Input Speed RPM (n1)			Motor Shaft Max $\phi$ $d_{MW}$	Input Inertia $J_1$	Tors. Stiffness $C_2$
		Nom. <sup>1)</sup> $M_{2N}$	Accel. $M_{2acc}$	Peak <sup>2)</sup> $M_{2NOT}$			Continuous		Cyclic			
Nom.	Exact	Nm	Nm	Nm	arcmin		EL 1,2,3,4	EL 5,6	All	mm	kgcm <sup>2</sup>	Nm/ arcmin

## F6 (continued from previous page)

69.64	975/14	1100	1100	2000	10/5	F602_0700 ME20	3500	3200	5500	$\leq 32$	5.1	77.0
						F602_0700 ME30			5000	$\leq 38$	10.0	
93.33	280/3	1100	1100	2000	10/5	F602_0930 ME20	3500	3200	5500	$\leq 32$	4.7	77.0
						F602_0930 ME30			5000	$\leq 38$	10.0	
112.2	9425/84	1100	1100	2000	10/5	F602_1120 ME20	3500	3200	5500	$\leq 24$	3.0	77.0
139.8	559/4	1100	1100	2000	10/5	F602_1400 ME20	3500	3200	5500	$\leq 24$	2.8	77.0
180.6	8671/48	1100	1100	2000	10/6	F603_1810 ME20	3500	3200	5500	$\leq 24$	2.8	77.0
215.4	1508/7	1100	1100	2000	10/6	F603_2150 ME20	3500	3200	5500	$\leq 24$	2.8	77.0
269.3	1885/7	1100	1100	2000	10/6	F603_2690 ME20	3500	3200	5500	$\leq 24$	2.8	77.0
360.9	3248/9	1100	1100	2000	10/6	F603_3610 ME20	3500	3200	5500	$\leq 24$	2.7	77.0
433.8	54665/126	1100	1100	2000	10/6	F603_4340 ME20	3500	3200	5500	$\leq 24$	2.7	77.0
540.4	16211/30	1100	1100	2000	10/6	F603_5400 ME20	3500	3200	5500	$\leq 24$	2.7	77.0

<sup>1)</sup> Maximum torque for continuous input 1500 RPM - horizontal output position.

<sup>2)</sup> Maximum momentary torque for emergency stops or heavy shock load. (Admissible stops per life of gearhead = 1,000 stops maximum.)

<sup>3)</sup> Backlash shown standard/reduced