



Dimensional Data

“V” Shaft Output with “F” Output Flange – All Sizes

* See Motor Mounting Plate Option, page 113 for details.

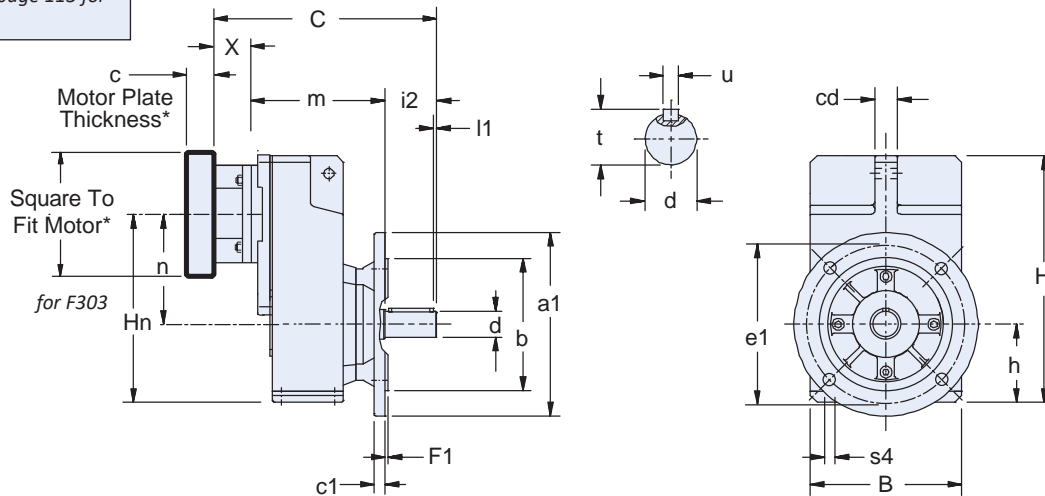

Table 1 Dimensions (mm)

Unit	a1	B	b _{j6}	c1	cd	e1	F1	H	h	Hn	i2	l1	n	s4
F1	160	145	110	10	20	130	3.5	238	74	176	50	5	102	9
F2	200	180	130	14	22	165	3.5	299	93	224	60	5	131	11
F3	250	206	180	15	30	215	4	335.5	106	219	70	5	149.5 ¹⁾	14
F4	250	230	180	15	30	215	4	370	116	285 ¹⁾	80	5	169 ¹⁾	14
F6	300	265	230	17	35	265	4	433	137	333	100	5	196	14

¹⁾ For F303, n is 113 with ME20; For F403, n is 132 with ME20 and Hn is 248.

Table 2 “V” Shaft Output Dimensions

Unit	Standard Shaft - in			Optional Shaft* - mm		
	d _{h6}	t	u	d _{k6}	t	u
F1	1.000	1.11	1/4 x 1/4 x 1-9/16	25	28	A8x7x40
F2	1.250	1.36	1/4 x 1/4 x 1-15/16	30	33	A8x7x50
F3	1.375	1.51	5/16 x 5/16 x 2-5/16	35	38	A10x8x60
F4	1.625	1.79	3/8 x 3/8 x 2-7/8	40	43	A12x8x70
F6	2.125	2.35	1/2 x 1/2 x 3-5/32	50	53.5	A14x9x90

*Metric output available on request

Table 3 Dimensions (mm)

Unit	ME10		ME20		ME30		ME40		Approx. Wt. lbs.
	C	m	C	m	C	m	C	m	
F102	219.5	129.5	233.5	133.5	—	—	—	—	38
F202	253	153	267	157	279	159	—	—	51
F203	290	190	—	—	—	—	—	—	64
F302	279.5	169.5	293.5	173.5	305.5	175.5	—	—	67
F303	316.5	206.5	336.5	216.5	—	—	—	—	73
F402	—	—	318.5	188.5	330.5	190.5	361.5	193.5	84
F403	341.5	221.5	361.5	231.5	—	—	—	—	91
F602	—	—	369.5	219.5	381.5	221.5	412.5	224.5	165
F603	—	—	412.5	262.5	—	—	—	—	177

Table 4 Motor Adapter Dimensions (mm)

Motor Adapter	Thickness ³⁾ c Min.	Motor Shaft d2 Max. ²⁾	X	Wt. lbs.
ME10	21	19	40	5
ME20	24	32	50	8
ME30	25	38	60	12
ME40	33	48	88	18

²⁾ If an adapter bushing is required it will be supplied as a component of the motor mounting plate.

³⁾ Motor plate maximum thickness (c) will vary with motor shaft length but will not be less than shown.

For approximate weight, add unit weight from Table 3 and adapter weight from Table 4.

F Series: OFFSET – Versatile Outputs

F Series: OFFSET – Versatile Outputs

“W” Single Bushing with “G” Pitch Circle Diameter (PCD) Tapped Holes – All Sizes

Important: For ease of installation, a 1/32" x 45° chamfer (minimum) is recommended for the output shaft end.

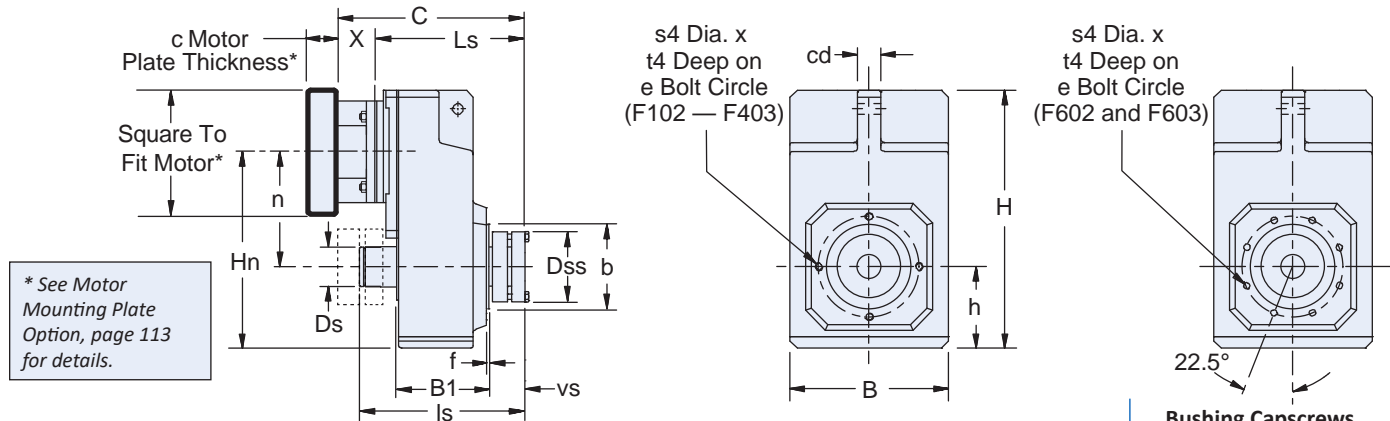

* See Motor Mounting Plate Option, page 113 for details.

Table 1 Dimensions (mm)

Unit	B	b ₆	B1	cd	Ds	Ds	Dss	e	f	H	h	Hn	ls	n	s4	t4	vs	Bushing Capscrews	
																		No. – Size Metric	Tightening Torque – Nm
F1	145	75	87	20	34.5	34.5	68	85	2.5	238	74	176	170.9	102	M8x1.25	13	30	6 – M6x25	10
F2	180	95	105	22	44.5	44.5	78	115	3	299	93	224	197.4	131	M8x1.25	13	39	8 – M6x30	10
F3	206	110	120	30	48	48	84	130	3.5	335.5	106	255.5	218.9	149.5 ¹⁾	M10x1.5	16	39	8 – M6x30	10
F4	230	110	135	30	54.5	54.5	97	130	3.5	370	116	285 ¹⁾	243.1	169 ¹⁾	M10x1.5	16	45	8 – M8x30	25
F6	265	130	166	35	64.5	64.5	105	165	3.5	433	137	333	275.3	196	M10x1.5	16	45	8 – M8x30	25

¹⁾ For F303, n is 113 with ME20; For F403, n is 132 with ME20 and Hn is 248.

Table 2 “WF” Single Side Bushings* – Stock Bores Sizes

Unit	Metric				Inches											
	20	30	35	3/4	1	1-3/16	1-1/4	1-3/8	1-7/16	1-1/2	1-5/8	1-11/16	1-3/4	1-7/8	1-15/16	2
F1	WF1-20	—	—	WF1-075	—	—	—	—	—	—	—	—	—	—	—	—
F2	—	WF2-30	—	—	WF2-100	WF2-103	—	—	—	—	—	—	—	—	—	—
F3	—	WF3-30	WF3-35	—	WF3-100	WF3-103	WF3-104	WF3-106	WF3-107	WF3-108	—	—	—	—	—	—
F4	—	—	—	—	WF4-100	WF4-103	WF4-104	WF4-106	WF4-107	WF4-108	—	—	—	—	—	—
F6**	—	—	—	—	—	—	—	—	WF5-107	WF5-108	WF5-110	WF5-111	WF5-112	WF5-114	WF5-115	WF5-200

*A complete bushing kit includes the locking ring assembly, tapered cone, support ring, and all hardware to mount the kit into the reducer. The bushing will accept a shaft with a tolerance of +0.000/-0.005.

** Bushing on side 6 is only available for 2 stage gear reducers without a cover.

Table 3 Dimensions (mm)

Unit	ME10		ME20		ME30		ME40		Approx. Wt. lbs.
	C	Ls	C	Ls	C	Ls	C	Ls	
F102	170	130	184	134	—	—	—	—	38
F202	197	157	211	161	223	163	—	—	51
F203	234	194	—	—	—	—	—	—	64
F302	212	172	226	176	238	178	—	—	67
F303	249	209	269	219	—	—	—	—	73
F402	—	—	247	197	259	199	290	202	84
F403	270	230	290	240	—	—	—	—	91
F602	—	—	278	228	290	230	321	233	165
F603	—	—	321	271	—	—	—	—	177

Table 4 Motor Adapter Dimensions (mm)

Motor Adapter	Thickness ³⁾ c Min.	Motor Shaft d2 Max. ²⁾	X	Wt. lbs.
ME10	21	19	40	5
ME20	24	32	50	8
ME30	25	38	60	12
ME40	33	48	88	18

²⁾ If an adapter bushing is required it will be supplied as a component of the motor mounting plate.

³⁾ Motor plate maximum thickness (c) will vary with motor shaft length but will not be less than shown.

For approximate weight, add unit weight from Table 3 and adapter weight from Table 4.



Dimensional Data

“W” Double Bushing with “G” Pitch Circle Diameter (PCD) Tapped Holes — Two Stage Units Only

Important: For ease of installation, a 1/32" x 45° chamfer (minimum) is recommended for the output shaft end. The double bushing cannot be mounted in sizes F203, F303, F403, or F603.

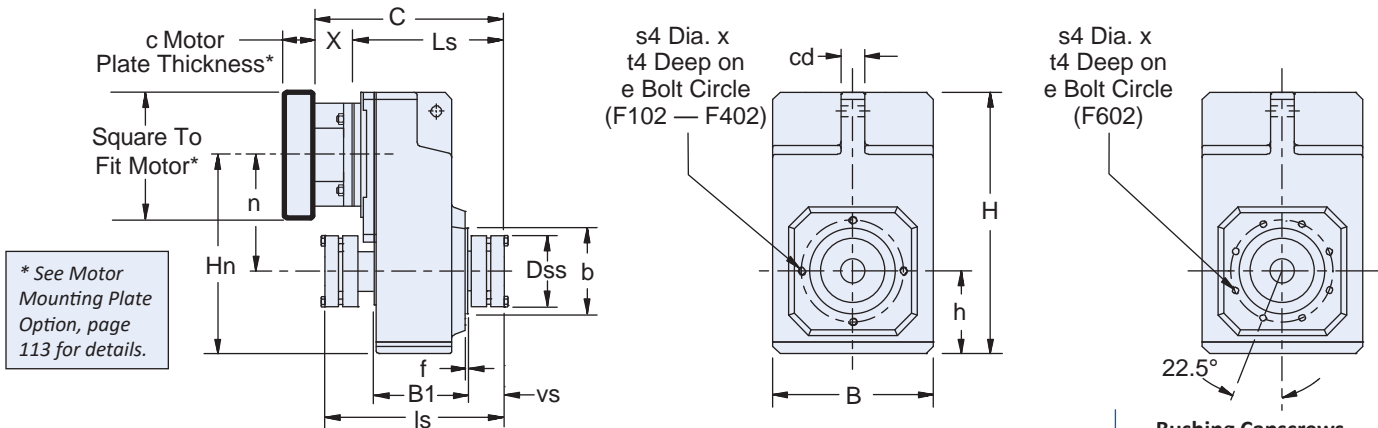

Table 1 Dimensions (mm)

Unit	B	b _{ig}	B1	cd	Dss	e	f	H	h	Hn	ls	n	s4	t4	vs	Bushing Capscrews	
																No. – Size Metric	Tightening Torque – Nm
F102	145	75	87	20	68	85	2.5	238	74	176	170.9	102	M8x1.25	13	30	6 – M6x25	10
F202	180	95	105	22	78	115	3	299	93	224	197.4	131	M8x1.25	13	39	8 – M6x30	10
F302	206	110	120	30	84	130	3.5	335.5	106	255.5	218.9	149.5	M10x1.5	16	39	8 – M6x30	10
F402	230	110	135	30	97	130	3.5	370	116	285	243.1	169	M10x1.5	16	45	8 – M8x30	25
F602	265	130	166	35	105	165	3.5	433	137	333	275.3	196	M10x1.5	16	45	8 – M8x30	25

Table 2 “WFN” Double Side Bushings* — Stock Bores Sizes

Unit	Metric				Inches													
	20	30	35	40	3/4	1	1-3/16	1-1/4	1-3/8	1-7/16	1-1/2	1-5/8	1-11/16	1-3/4	1-7/8	1-15/16	2	
F102	WFN1-20	—	—	—	WFN1-075	—	—	—	—	—	—	—	—	—	—	—	—	—
F202	—	WFN2-30	—	—	—	WFN2-100	WFN2-103	—	—	—	—	—	—	—	—	—	—	—
F302	—	WFN3-30	WFN3-35	—	—	WFN3-100	WFN3-103	WFN3-104	WFN3-106	WFN3-107	WFN3-108	—	—	—	—	—	—	—
F402	—	—	—	WFN4-40	—	WFN4-100	WFN4-103	WFN4-104	WFN4-106	WFN4-107	WFN4-108	—	—	—	—	—	—	—
F602	—	—	—	WFN5-40	—	—	—	—	—	WFN5-107	WFN5-108	WFN5-110	WFN5-111	WFN5-112	WFN5-114	WFN5-115	WFN5-200	

*A complete bushing kit includes the locking ring assembly, tapered cone, support ring, and all hardware to mount the kit into the reducer. The bushing will accept a shaft with a tolerance of +0.000/-0.005.

Table 3 Dimensions (mm)

Unit	ME10		ME20		ME30		ME40		Approx. Wt. lbs.
	C	Ls	C	Ls	C	Ls	C	Ls	
F102	170	130	184	134	—	—	—	—	38
F202	197	157	211	161	223	163	—	—	51
F302	212	172	226	176	238	178	—	—	67
F402	—	—	247	197	259	199	—	—	84
F602	—	—	278	228	290	230	321	233	165

Table 4 Motor Adapter Dimensions (mm)

Motor Adapter	Thickness ³⁾ c Min.	Motor Shaft d2 Max. ²⁾	X	Wt. lbs.
ME10	21	19	40	5
ME20	24	32	50	8
ME30	25	38	60	12
ME40	33	48	88	18

²⁾ If an adapter bushing is required it will be supplied as a component of the motor mounting plate.

³⁾ Motor plate maximum thickness (c) will vary with motor shaft length but will not be less than shown.

For approximate weight, add unit weight from Table 3 and adapter weight from Table 4.

F Series: OFFSET – Versatile Outputs

“A” Hollow Output with “F” Output Flange – All Sizes

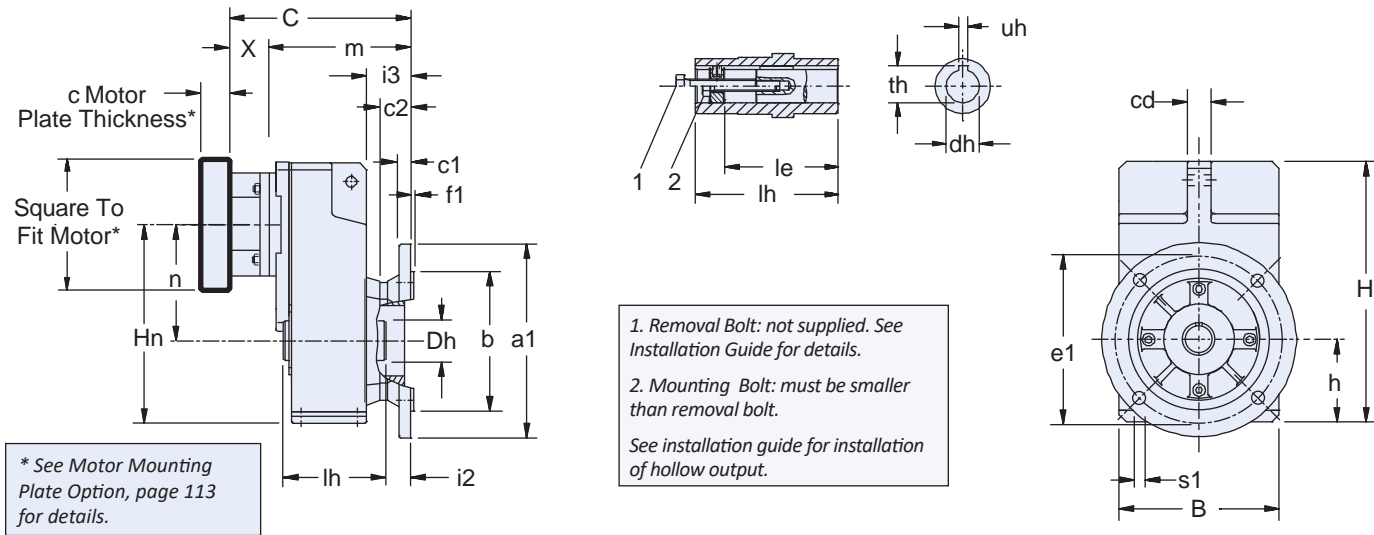

Table 1 Dimensions (mm)

Unit	a1	B	b _{j6}	c1	c2	cd	Dh	e1	f1	H	h	Hn	i2	i3	le	lh	s1	n
F1	160	145	110	10	32	20	35	130	3.5	238	74	176	25.5	44.5	73	95	9	102
F2	200	180	130	14	38	22	45	165	3.5	299	936	224	30	53	92	115	11	131
F3	250	206	180	15	40	30	50	215	4	335.5	106	255.5 ¹⁾	31.5	56.5	103	130	14	149.5 ¹⁾
F4	250	230	180	15	40	30	55	215	4	370	116	285 ¹⁾	31.5	56.5	114	145	14	169 ¹⁾
F6	300	265	230	17	40	35	70	265	4	433	137	333	29.5	60.5	143	180	14	196

¹⁾ For F303, Hn is 219 and n is 113 with ME20 For F403, Hn is 248 and n is 132 with ME20

Table 2 “A” Hollow Bore Dimensions (mm)

Unit	Standard Bore - inches			Optional Bore* - mm		
	dh _{g7}	th	uh	dh _{H7}	th	uh _{J59}
F1	0.750	0.84	0.187	20	22.8	6
F2	1.000	1.12	0.250	25	28.3	8
F3	1.250	1.37	0.250	30	33.3	8
F4	1.500	1.67	0.375	40	43.3	12
F6	2.000	2.23	0.500	50	53.8	14

For approximate weight, add unit weight from Table 3 and adapter weight from Table 4.

*Metric output available on request.

Table 3 Dimensions (mm)

Unit	ME10		ME20		ME30		ME40		Approx. Wt. lbs.
	C	m	C	m	C	m	C	m	
F102	169.5	129.5	183.5	133.5	—	—	—	—	38
F202	193	153	207	157	219	159	—	—	51
F203	230	190	—	—	—	—	—	—	64
F302	209.5	169.5	223.5	173.5	235.5	175.5	—	—	67
F303	246.5	206.5	266.5	216.5	—	—	—	—	73
F402	—	—	238.5	188.5	250.5	190.5	281.5	193.5	84
F403	261.5	221.5	281.5	231.5	—	—	—	—	91
F602	—	—	269.5	219.5	281.5	221.5	312.5	224.5	165
F603	—	—	312.5	262.5	—	—	—	—	177

Table 4 Motor Adapter Dimensions (mm)

Motor Adapter	Thickness ³⁾ c Min.	Motor Shaft d2 Max. ²⁾	X	Wt. lbs.
ME10	21	19	40	5
ME20	24	32	50	8
ME30	25	38	60	12
ME40	33	48	88	18

²⁾ If an adapter bushing is required it will be supplied as a component of the motor mounting plate.

³⁾ Motor plate maximum thickness (c) will vary with motor shaft length but will not be less than shown.



Dimensional Data

"A" Hollow Output with "G" Pitch Circle Diameter (PCD) Tapped Holes – All Sizes

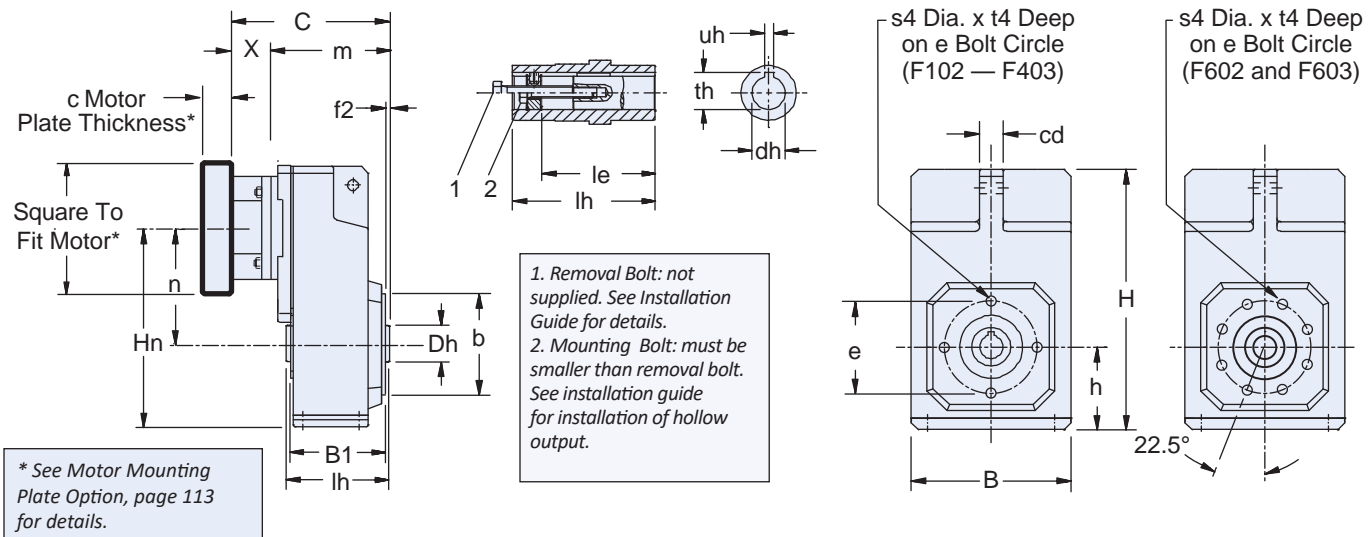

Table 1 "Dimensions (mm)

Unit	B	B1	b _{j6}	cd	Dh	e	f2	H	h	Hn	le	lh	n	s4	t4
F1	145	87	70	20	35	85	2.5	238	74	176	73	95	102	M8x1.25	13
F2	180	105	95	22	45	115	3	299	93	224	92	115	131	M8x1.25	13
F3	206	120	110	30	50	130	3.5	335.5	106	255.5 ¹⁾	103	130	149.5 ¹⁾	M10x1.5	16
F4	230	135	110	30	55	130	3.5	370	116	285 ¹⁾	114	145	169 ¹⁾	M10x1.5	16
F6	265	166	130	35	70	165	3.5	433	137	333	143	180	196	M10x1.5	16

¹⁾ For F303, Hn is 219 with ME20 and n is 113; For F403, Hn is 248 with ME20 and n is 132

Table 2 "A" Hollow Bore Dimensions (mm)

Unit	Standard Bore - inches			Optional Bore* - mm		
	dh _{g7}	th	uh	dh _{H7}	th	uh _{J59}
F1	0.750	0.84	0.187	20	22.8	6
F2	1.000	1.12	0.250	25	28.3	8
F3	1.250	1.37	0.250	30	33.3	8
F4	1.500	1.67	0.375	40	43.3	12
F6	2.000	2.23	0.500	50	53.8	14

*Metric output available on request.

Table 3 Dimensions (mm)

Unit	ME10		ME20		ME30		ME40		Approx. Wt. lbs.
	C	m	C	m	C	m	C	m	
F102	144	104	158	108	—	—	—	—	38
F202	163	123	177	127	189	129	—	—	51
F203	200	160	—	—	—	—	—	—	64
F302	178	138	192	142	204	144	—	—	67
F303	215	175	235	185	—	—	—	—	73
F402	—	—	207	157	219	159	250	162	84
F403	230	190	250	200	—	—	—	—	91
F602	—	—	240	190	252	192	283	195	165
F603	—	—	283	233	—	—	—	—	177

For approximate weight, add unit weight from Table 3 and adapter weight from Table 4.

Table 4 Motor Adapter Dimensions (mm)

Motor Adapter	Thickness ³⁾ c Min.	Motor Shaft d2 Max. ²⁾	X	Wt. lbs.
ME10	21	19	40	5
ME20	24	32	50	8
ME30	25	38	60	12
ME40	33	48	88	18

²⁾ If an adapter bushing is required it will be supplied as a component of the motor mounting plate.

³⁾ Motor plate maximum thickness (c) will vary with motor shaft length but will not be less than shown.

F Series: OFFSET – Versatile Outputs

F Series: OFFSET – Versatile Outputs

“A” Hollow Output with “NG” Foot Mounting – All Sizes

See Rubber Buffer
Option below for
mounting torque arms.

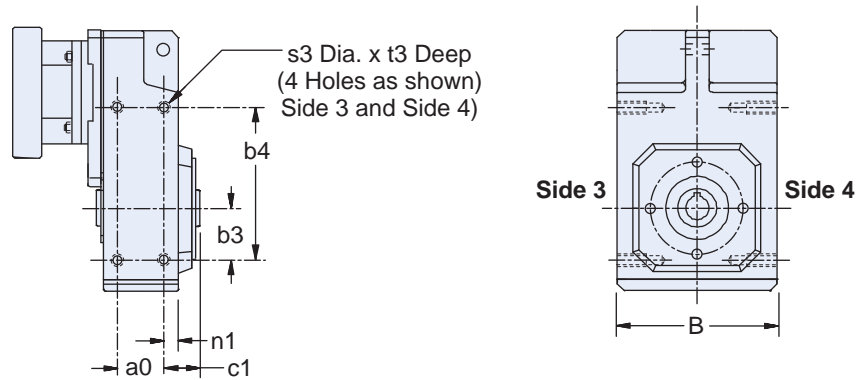

Table 1 Dimensions (mm)

Unit	a0	B	b3	b4	c1	n1	s3	t3
F1	50	142	40	140	29	10	M6	11
F2	64	176	55	175	33.5	10.5	M8	13
F3	72	204	60	200	37.5	12.5	M10	16
F4	87	228	70	220	37.5	12.5	M10	16
F6	108	262	85	270	46.5	15.5	M12	19

Rubber Buffer Option

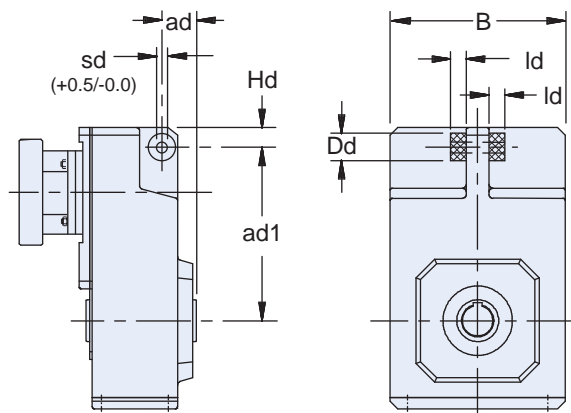

Table 2 “Rubber Buffer Dimensions (mm)

Unit	Part No.	ad	ad1	B	Dd	Hd	Id	sd
F1	25192	35	150	142	30	14	15	11
F2	25192	40	181	176	30	25	15	11
F3	25193	45	205	204	40	24.5	20	12.5
F4	25193	45	228	228	40	26	20	12.5
F6	25194	55	270	262	60	26	30	21

Order two (2) rubber buffers for each unit.

Torque arms are not supplied by STÖBER.



Dimensional Data

"S" Shrink Ring with "G" Pitch Circle Diameter (PCD) Tapped Holes – All Sizes

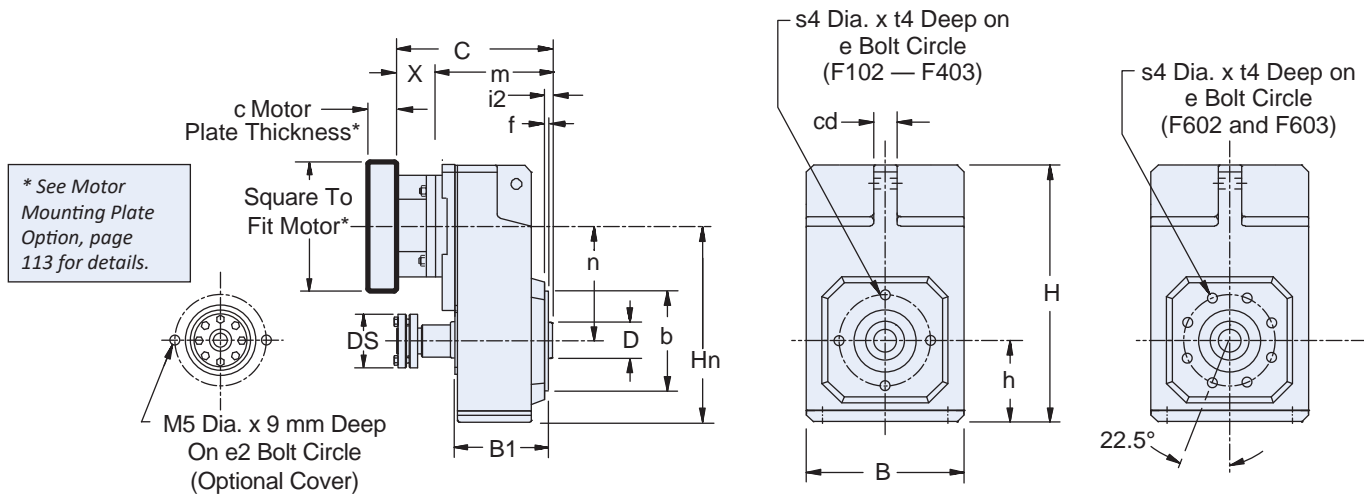

Table 1 Shaft Dimensions (mm)

Unit	B	B1	b _{j6}	cd	d _{h9}	D	Bore d ^{H7}	Shaft d _{h9}	d3	d4
F1	145	87	70	20	20	35	20	20	24	20.5
F2	180	105	95	22	25	45	25	25	30	25.5
F3	206	120	110	30	30	50	30	30	36	30.5
F4	230	135	110	30	40	55	40	40	50	40.5
F6	265	166	130	35	50	70	50	50	62	50.5

Table 2 Dimensions (mm)

Unit	DS	e	e2	f	H	h	Hn	i2	IHS	m ²	m ³	m ⁴	m ⁵	n	s4	t4
F1	50	85	58	2.5	238	74	176	6.5	146	20	31	25	26	102	M8x1.25	13
F2	60	115	72	3	299	93	224	8	175	20	37	25	32	131	M8x1.25	13
F3	72	130	78	3.5	335.5	106	255.5	8.5	192	25	37	30	32	149.5	M10x1.5	16
F4	90	130	83	3.5	370	116	285 ²⁾	8.5	210	40	45	45	40	169 ¹⁾	M10x1.5	16
F6	106	165	102	3.5	433	137	333	10.5	248	40	47	45	42	196	M10x1.5	16

¹⁾ For F303, Hn is 219 with ME20 and n is 113; For F403, Hn is 248 with ME20 and n is 132

Table 3 Dimensions (mm)

Unit	ME10		ME20		ME30		ME40		Approx. Wt. lbs.
	C	m	C	m	C	m	C	m	
F102	144	104	158	108	—	—	—	—	38
F202	163	123	177	127	189	129	—	—	51
F203	200	160	—	—	—	—	—	—	64
F302	178	138	192	142	204	144	—	—	67
F303	215	175	235	185	—	—	—	—	73
F402	—	—	207	157	219	159	250	162	84
F403	230	190	250	200	—	—	—	—	91
F602	—	—	240	190	252	192	283	195	165
F603	—	—	283	233	—	—	—	—	177

Table 4 Motor Adapter Dimensions (mm)

Motor Adapter	Thickness ³⁾ c Min.	Motor Shaft d2 Max. ²⁾	X	Wt. lbs.
ME10	21	19	40	5
ME20	24	32	50	8
ME30	25	38	60	12
ME40	33	48	88	18

²⁾ If an adapter bushing is required it will be supplied as a component of the motor mounting plate.

³⁾ Motor plate maximum thickness (c) will vary with motor shaft length but will not be less than shown.

For approximate weight, add unit weight from Table 3 and adapter weight from Table 4.

F Series: OFFSET – Versatile Outputs