

C Series: INLINE — Shaft Output

C Features

- 2:1 to 276:1 ratios (higher ratios available. Contact STÖBER.)
- Quiet running (As low as 53dB(A))
- Mounting flexibility to fit the application
- Adaptability: shafts available in metric or imperial, carbon or stainless steel to meet your requirements
- Optional food and corrosion resistant package
- Dual seals for extreme duty applications
- Error free motor mounting and quick changeover with toleranced pilot on motor plate
- Magnetic oil filtration to remove contaminants to prevent breakdowns
- Build and ship in one day
- Assembled in the USA

The STÖBER C Series offer performance, durability, and economy for a wide range of applications. High efficiency helical gearing keeps motor size to a minimum while running almost silently. Easily install the C series with a variety of mounting configurations, including the foot mounted option. Every gearbox is made to order. STÖBER will custom whatever you need to fit your application. Contact us today to learn more.

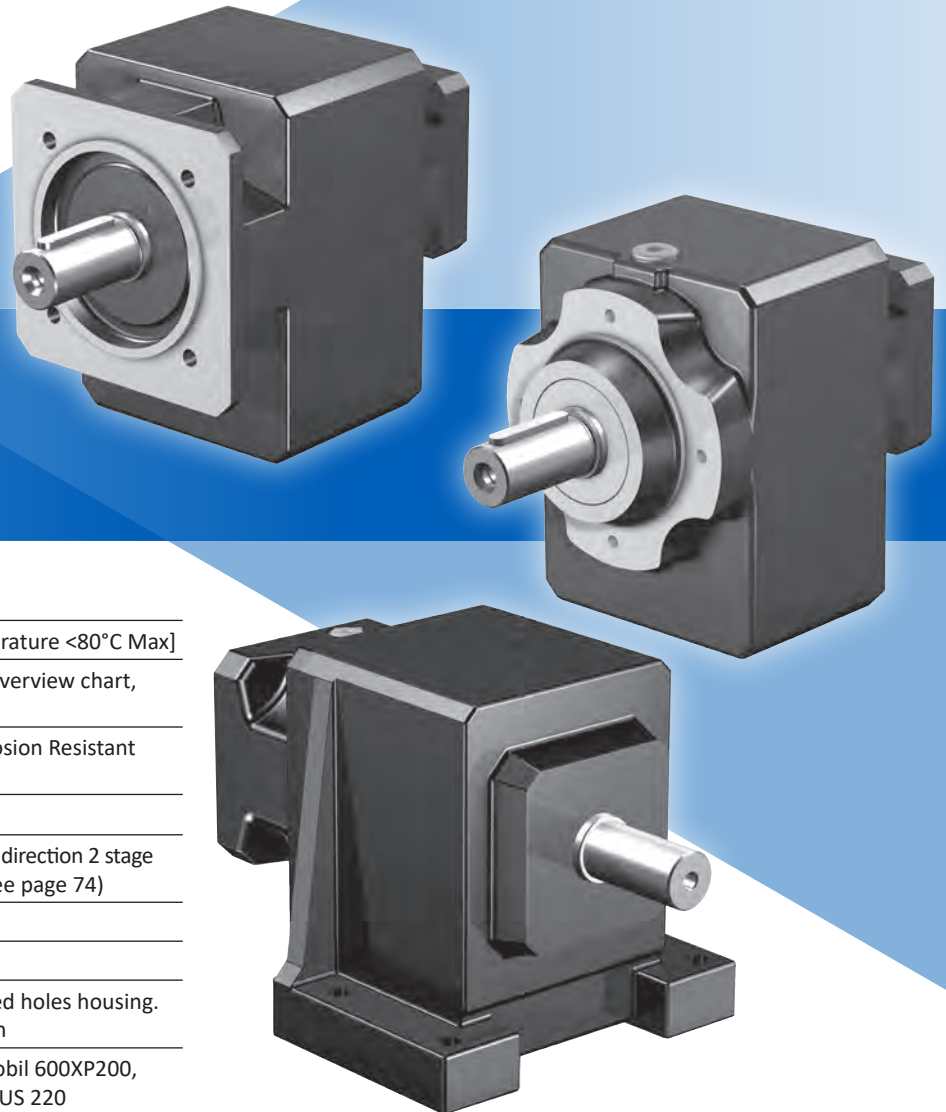

**SHIPS in
1 DAY!**
NO EXPEDITE FEE FOR 24
HOUR SERVICE

General Specifications

Ambient Temperature	0°C to +40°C (104°F) [Unit temperature <80°C Max]
Backlash	≤10 arcmins, (see performance overview chart, (page 75))
Coating	Standard Black (RAL-9005), Corrosion Resistant option, Food option
Degree of Protection	IP65
Direction of Rotation	Input and output rotate the SAME direction 2 stage units, opposite for 3 stage units (see page 74)
Efficiency	2 stage 97%; 3 stage 96%
Input RPM	Up to 6,000 RPM
Installation	Requires 10.9 fasteners for tapped holes housing. See page 306 for more information
Lubrication	Lubricated for life* - standard Mobil 600XP200, option food grade Mobil SHC CIBUS 220
Mounting Position	Must be specified, see page 74
Warranty	5 Year Limited (2 Years on normal wear items: bearings, seals, etc.)

* Scheduled lubrication is required for some larger frame C Series units (excluding F Food Duty and B Corrosion Resistant option). See page 77 for lubrication details.

Benefits of NEW ME Motor Adapters

- Higher torques
- Higher input speeds
- More compact with square coupling housing
- More clamp ring options, so less need for adapter bushings
- Clamp ring with roll pin

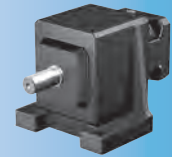

Overview

Selection Options At-a-Glance

Using the **Selection Data** table later in this section, select the C Series Gearhead with the appropriate performance and design options tailored to your motor choice and exact application requirements. Use the part number guide below as a reference to build a part number for the complete gearhead assembly.

Part Number Examples: 1 2 3 4 5 6 7 8 C 0 0 2 F 0020 ME10 B EL1*

Design Option	Part Number Code	Description
1 Series	C	Concentric inline helical
2 Size	0 1 2 3 4 5 6 7 8 9	10 sizes of gearhead
3 Generation	0 1	Version of gearhead
4 # of Stages	2 3	Two stage for ratios <70:1 Three stage >40:1
5 Housing	F G N Q	Round output flange Pitch Circle Diameter (PCD) tapped holes Foot mounting Square output flange (not bolt-on type)
6 Ratio	0020	Ratios range from 2:1 to 276:1 (0020=2:1; 0063=6.3:1; 2700=270:1)
7 Motor Adapter	ME10 – ME50	5 input sizes (see also motor mounting plate option)
8 Options	B F	Corrosion Resistant Duty (size C0 thru C8 only) Food Duty (size C0 thru C8 only)
* Mounting Position	EL1 EL2 EL3 EL4 EL5 EL6	Required special instruction for all units, see page 74

C Series: INLINE – Shaft Output

Options

ME Adapter Option

- MSS1 Seal – special input seal for longer life. Contact factory for this option.
- Peak Torque Booster – pinion securing element for shock loads, increasing peak torque up to 80%.

Lubrication Options

- Food grade or synthetic optionally available. Contact factory for this option.

Integrated Safety Brake

- ServoStop – provides dynamic braking during power failures or emergency stops in hazardous situations. Contact factory for this option.

Coating Option

- Corrosion Resistant Duty (**B** special option)
- Food Duty (**F** special option)

Food and Corrosion Resistant units are lubricated for life with double output seals (where possible), stainless output shaft, and heat cured paint.

ATEX

- ATmosphere EXplosible – rated for explosive environments. Contact factory for this option and allow additional time for delivery.

C Series: INLINE – Shaft Output

C Series Performance Overview

C Series performance is dependent on several factors including duty cycle, bearing design, gearhead size and stage configuration, among others. Use the chart below for preliminary evaluation, then use the following performance chart and selection information on the following pages for specific performance sizing and selection.

Size/Generation		C00	C10		C20		C30		
# of Stages		2	2	3	2	3	2	3	
Permissible Acceleration Torque	M_{2BMAX} Nm	72	140		230		400		
Output Torque Nom.	M_{2N} Nm	60	120		200		350		
Torsional Stiffness	C_2 Nm/arcmin	≤1.6	≤3.9	≤3.9	≤8.3	≤8.3	≤8.7	≤8.7	
Torsional Backlash ¹⁾	$\Delta\phi$ arcmin	≤16	≤15	≤15	≤14	≤16	≤13	≤13	
Input Speed Max. n_{1MAX}	Continuous	EL1, 2, 3, 4 (N1DBH)	4000	4000	4000	4000	4000	3700	3800
		EL5, 6 (N1DBV)	4000	3900	3900	3900	3900	3500	3500
	Cyclic	6000	6500	6500	6500	6500	6000	6000	
Efficiency (@nom torque)	%	97	97	96	97	96	97	96	
Weight	kg lbs	8.2 18	13.1 29	15.4 34	17.2 38	20.4 45	22.2 49	25.4 56	
Noise ²⁾	dB(A)	≤55	≤55		≤53		≤53		
Axial Load Max.	F_{2AMAX} N	500	850		1050		1400		
Radial Load Max. ³⁾	F_{2RMAX} N	1900	3400		4200		5650		
Tilting Moment Max. ³⁾	M_{2KMAX} Nm	80	190		260		350		

¹⁾ Tested at 1.5% of nominal torque and recorded on the output side of the gearhead. For lower backlash, contact STÖBER technical support.

²⁾ Measurement at one (1) meter distance with input speed (n_i) of 1500 RPM.

To calculate torque at higher input speeds, contact the factory.

³⁾ Rating based on output speed (n_o) of 20 RPM. For values at other speeds see page 77.

C Series Direction of Rotation

All 2 Stage Units

C002 C612
C102 C712
C202 C812
C302 C912
C402
C502

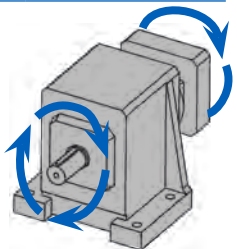

All 3 Stage Units

C103 C613
C203 C713
C303 C813
C403 C913
C503

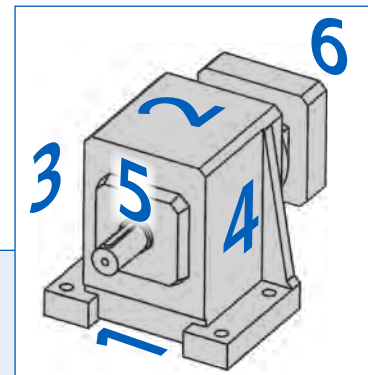
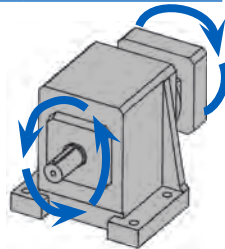

C Series Mounting Position Options

When ordering, the Mounting Position **MUST BE SPECIFIED** using one of the Mounting Position order codes below.

Note: the code relates to the unit's orientation side that faces down.

For example, EL1 has side 1 facing down, EL2 has side 2 facing down, etc.

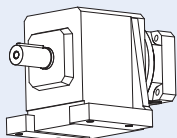

EL1

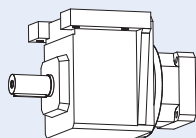

EL2

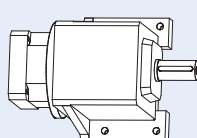

EL3

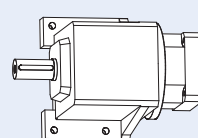

EL4

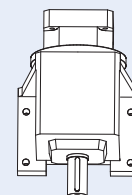

EL5

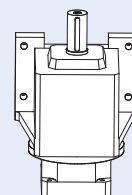

EL6



Overview

C Series: INLINE — Shaft Output

C40		C50		C61		C71		C81		C91	
2	3	2	3	2	3	2	3	2	3	2	3
600		920		1650		2760		4800		7210	8000
550		800		1450		2400		4200		6000	7000
≤22.0	≤22.0	≤23	≤23	≤74	≤74	≤122	≤122	≤204	≤204	≤392	≤393
≤12	≤12	≤12	≤12	≤10	≤10	≤10	≤10	≤10	≤10	≤10	≤10
3500	3500	3400	3400	3200	3200	3100	3100	2900	2900	2500	2800
3200	3200	3000	3000	2900	2900	2900	2900	2700	2700	2500	2600
5500	5500	5000	5000	4500	4500	4500	4500	4300	4300	4000	4000
97	96	97	96	97	96	97	96	97	96	97	96
32.2 71	35.3 78	43.0 95	50.3 111	52.1 115	72.0 159	90.1 199	100.1 221	145.9 322	154.9 342	270.0 596	307.1 678
≤61		≤61		≤61		≤67		≤67		≤73	
2400		3000		4000		5500		7500		9500	
9700		11,000		16,000		22,000		30,000		37,000	
750		900		1500		2400		3700		5200	

C Series Solid Output Shaft Options

Diameters in **BOLD BLUE** are readily available from inventory. Contact STÖBER Drives for delivery on other output sizes.

		C0	C1	C2	C3	C4	C5	C6	C7	C8	C9
Carbon Steel	Inches	3/4	1	1-1/4	1-1/4	1-5/8	1-5/8	2-1/8	2-3/8	2-7/8	3-5/8
	Metric	20	25	30	30	40	40	50	60	70	90
Stainless Steel*	Inches	3/4	1	1-1/4	1-1/4	1-5/8	1-5/8	2-1/8	2-3/8	2-7/8	—
	Metric	—	—	—	25	—	—	—	—	—	—

* Stainless steel options are ideal for food and corrosion resistant, harsh washdown environments.

C Series Standard & Optional Output Flange Sizes

BOLD BLUE are the standard flange size shipped with the unit unless otherwise specified. Optional flanges are not available for all sizes.

C0	C1	C2	C3	C4	C5	C6	C7	C8	C9
120	140	160	160	200	250	300	350	350	450
140	160	200	200	250	300			400	
160	200	250	250	300				450	

C Series: INLINE — Shaft Output

C Series Motor Mounting Plate Option (Motor information required with Motor Adapter ME option)

STOBER Servo Gearheads fit the motor of your choice with the appropriate motor mounting plate assembled between the motor and the gearhead.

NOTE: When ordering a gearhead:

- Specify the motor manufacturer and part number
- Provide the motor drawing with dimensions, or specify the motor mounting dimensions (per the list shown at right)

For a precise dimension on a specific motor, or for general assistance, we recommend you contact STOBER Technical Support.

Customer Required Dimensions for Properly Sized Motor Mounting Plate

d2	Motor Shaft Diameter (If an adapter bushing is required it will be supplied with the motor plate.)	
b6	Pilot Diameter	
e6	Bolt Circle Diameter	
s6	Bolt Diameter	
l5	Motor Shaft Length	
f6	Pilot Length	
a6	Square Flange (Optional – motor plate will typically be made to match this dimension.)	

Motor Mounting Plate Dimensions — mm (Gearhead Part Number Specific)

	ME10	ME20	ME30	ME40	ME50
Maximum Allowed Motor Shaft Dia. d2	19	32	38	48	60
Minimum Allowed Motor Plate Thickness c*	21	24	26	35	43

* Note that the c motor plate thickness is determined by the motor shaft length. The minimum motor plate thickness is the value listed.

C Series Motor Mounting Plate Access Hole

Access to the clamping screw for the motor coupling is located on the 270° side of the motor mounting plate at the location shown. If necessary, the motor mounting plate can be rotated in the field, if a 0°, 90° or 180° orientation for the access hole is desirable.

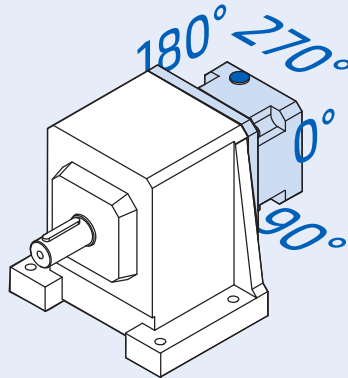

Permissible Motor Tilting Torque

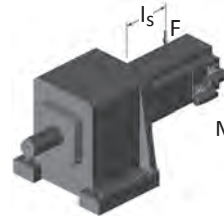

$$M_{1k} = F \times l_s \leq M_{1K}$$

The permissible tilting torque of the motor attached to the gear unit is a result of the static and dynamic load "F" from the motor weight, mass acceleration, and vibration multiplied by the distance from the center of gravity "l_s" of the motor.

Permissible Output Shaft Load and Tilting Moments*

Unit	Z ₂ mm	F _{2A} N	F _{2R} N	M _{2K} Nm
C0	20	500	1900	80
C1	30	850	3400	190
C2	30	1050	4200	260
C3	30	1400	5650	350
C4	35	2400	9700	750
C5	42	3000	11,000	900
C6	40	4000	16,000	1500
C7	45	5500	22,000	2400
C8	50	7500	30,000	3700
C9	55	9500	37,000	5200

* Refer to illustration and definitions on page 77. During EMERGENCY OFF operation (maximum stops per gearhead = 1000) the permissible values in the table for F_{2A}, F_{2R}, and M_{2K} can be multiplied by a factor of 2. The permissible load values given are valid with the load applied to the center of the output shaft (x₂).

M _{1K}	ME10	ME20	ME30	ME40	ME50
Nm	25	60	125	250	600

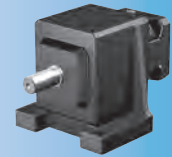

Overview

C Series Lubrication Maintenance

With STÖBER reducers very little maintenance is required under normal operating conditions. Units C002 thru C502/ C503 are supplied without breathers and are lubricated for life and maintenance free. Breathers are provided on standard units C612/C613 thru C912/C913, located as shown to the right*. STÖBER recommends changing the lubrication in breather supplied units after 10,000 hours for normal operating conditions or every 5000 hours for wet operating conditions.

*C612/C613 and larger units with the Food & Corrosion Resistant option exclude a breather. Contact STÖBER for details.

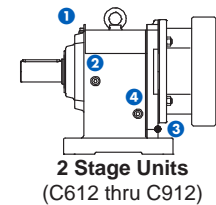

2 Stage Units
(C612 thru C912)

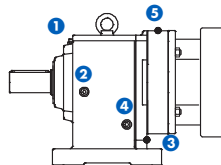

3 Stage Units
(C613 thru C913)

Drain Plug and Vent Location

Mounting Position	1	2 *	2a *	3	4	5
EL1	Vent			Drain		
EL2	Drain			Vent		
EL3		Vent	Drain			
EL4		Drain	Vent			
EL5	C612-C912	Drain		Vent		
	C613-C913	Drain				Vent
EL6	Vent			Drain		

* Position 2a is on the opposite side of 2.

Overhung Load Calculations

Pulling forces or overhung load of pulleys, sheaves, sprockets, etc. on the reducer output shaft must not exceed the allowable limits shown in the load/life/speed calculations below.

Note: Overhung load is measured at the center of the shaft extension. No overhung load is encountered when a reducer is flange mounted and/or coupling connected to another unit. However, the shafts of all components must be accurately aligned and secured to prevent pre-loading of the bearings and premature bearing failure.

Use the following formula to determine actual overhung load for a given drive:

$$\text{Imperial OHL (lbs)} = \frac{126,000 \times \text{HP} \times K}{D \times n}$$

$$\text{Metric OHL (N)} = \frac{19,100 \times \text{kW} \times K}{D \times n}$$

Where:

- OHL** Overhung load
- HP** Horsepower
- kW** Transmitted Kilowatt
- D** Pitch Diameter (inches or meters) of Sprocket, Gear, Sheave, Pulley, etc.
- n** Maximum Shaft RPM
- K** 1.00 Single Chain Drive; 1.25 Timing Belt Drive;
1.25 Spur or Helical Gear Drive; 1.50 V-Belt Drive; 2.50 Flat Belt Drive

C Series Load/Life/Speed Calculations

The permissible load and tilting moment values are based on an output speed of 20 RPM. For higher speeds the following applies, where n_2 is the desired speed:

$$F_{2axN} = \frac{F_{2ax20}}{\sqrt[3]{\frac{n_{2m*}}{20 \text{ rpm}}}} \quad F_{2radN} = \frac{F_{2rad20}}{\sqrt[3]{\frac{n_{2m*}}{20 \text{ rpm}}}} \quad M_{2kN} = \frac{M_{2k20}}{\sqrt[3]{\frac{n_{2m*}}{20 \text{ rpm}}}}$$

The application output tilting moment should be determined by the following formula:

$$M_{2k*} = \frac{2 \cdot F_{2ax*} \cdot Y_2 + F_{2rad*} \cdot (X_2 + Z_2)}{1000} \leq M_{2kN}$$

$$F_{2rad*} \leq F_{2radN} \quad F_{2ax*} \leq F_{2axN}$$

Where:

- Z₂** Distance of Shaft Shoulder to Center of Output Bearing
- n₂** Actual Average Output Speed
- X₂** Distance of the Shaft Shoulder to the Force Application Point
- Y₂** Distance of the Shaft Axis to the Axial Force Application Point
- F_{2ax*}** Actual Axial Force at Gear Unit Output
- F_{2ax100}** Permitted Axial Force
- F_{2rad100}** Permitted Radial Force ≤100RPM

All formulas shown are based on METRIC values

Upper case letters are permissible values. Lower case letters are for existing values.

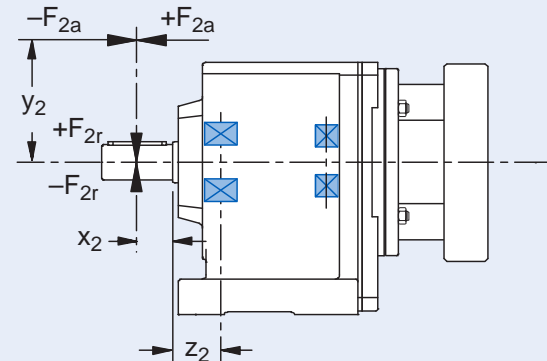

- F_{2rad,acc}** Radial Acceleration Force
- F_{2rad,acc*}** Radial Acceleration Force at Gear Unit Output
- M_{2K100}** Permitted Tilting Torque ≤100RPM
- M_{2K,acc}** Permitted Acceleration Tilting Torque
- M_{2k,acc*}** Permitted Acceleration Tilting Torque at Gear Unit Output
- C_{2K}** Tilting Stiffness

C Series: INLINE — Shaft Output

C Series: INLINE – Shaft Output

Reducer Ratio (i)		Output Torque			Backlash $\Delta\phi_2$	Part Number (Gearhead + Input)	Max. Input Speed RPM (n1)			Motor Shaft Max ϕ d _{MW}	Input Inertia J ₁	Tors. Stiffness C ₂
		Nom. ¹⁾ M _{2N}	Accel. M _{2acc}	Peak ²⁾ M _{2NOT}			Continuous	Cyclic				
Nom.	Exact	Nm	Nm	Nm	arcmin	EL 1,2,3,4	EL 5,6	All	mm	kgcm ²	Nm/ arcmin	

C0 (continued next page)

1.997	1480/741	35	46	58	20	C002_0020 ME10	3500	3000	6000	≤19	1.4	1.2
						C002_0020 ME20				≤24	3.3	
2.769	36/13	39	58	81	20	C002_0028 ME10	3500	3000	6000	≤19	1.1	1.2
						C002_0028 ME20				≤24	3.0	
3.067	46/15	40	60	89	20	C002_0031 ME10	3700	3600	6000	≤19	1.0	1.2
						C002_0031 ME20				≤24	2.9	
3.318	1702/513	41	62	97	20	C002_0033 ME10	3700	3600	6000	≤19	1.0	1.2
						C002_0033 ME20				≤24	2.9	
3.835	441/115	43	65	110	20	C002_0038 ME10	3700	3600	6000	≤19	0.9	1.2
						C002_0038 ME20				≤24	2.8	
4.149	1813/437	44	65	110	20	C002_0041 ME10	3700	3600	6000	≤19	0.9	1.2
						C002_0041 ME20				≤24	2.8	
4.680	117/25	46	65	110	20	C002_0047 ME10	4000	4000	6500	≤19	0.8	1.2
						C002_0047 ME20	3700	3700	6000	≤24	2.7	
5.063	481/95	47	65	110	20	C002_0051 ME10	4000	4000	6500	≤19	0.8	1.2
						C002_0051 ME20	3700	3700	6000	≤24	2.7	
5.824	99/17	49	65	110	20	C002_0058 ME10	4000	4000	6500	≤19	0.8	1.2
						C002_0058 ME20	3700	3700	6000	≤24	2.7	
6.300	2035/323	51	65	110	20	C002_0063 ME10	4000	4000	6500	≤19	0.8	1.2
						C002_0063 ME20	3700	3700	6000	≤24	2.7	
7.714	54/7	54	65	110	20	C002_0077 ME10	4000	4000	7000	≤19	0.7	1.2
						C002_0077 ME20	3700	3700	6000	≤24	2.6	
8.235	667/81	60	72	120	16	C002_0082 ME10	3700	3600	6000	≤19	0.9	1.6
						C002_0082 ME20				≤24	2.8	
9.228	1495/162	60	65	120	16	C002_0092 ME10	3700	3600	6000	≤19	0.9	1.6
						C002_0092 ME20				≤24	2.8	
10.30	1421/138	60	72	120	16	C002_0105 ME10	3700	3600	6000	≤19	0.8	1.6
						C002_0105 ME20				≤24	2.7	
11.54	3185/276	60	65	120	16	C002_0115 ME10	3700	3600	6000	≤19	0.8	1.6
						C002_0115 ME20				≤24	2.7	
12.57	377/30	60	72	120	16	C002_0125 ME10	4000	4000	6500	≤19	0.8	1.6
						C002_0125 ME20	3700	3700	6000	≤24	2.7	

¹⁾ Maximum torque for continuous input 1500 RPM - horizontal output position.

²⁾ Maximum momentary torque for emergency stops or heavy shock load. (Admissible stops per life of gearhead = 1,000 stops maximum.)

* Motor shaft adapter code (shaft diameter max - mm): ME10 (19), ME20 (32), ME30 (38), ME40 (48), ME50 (60)

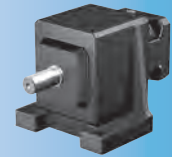

Selection Data

Reducer Ratio (i)		Output Torque			Backlash $\Delta\phi_2$	Part Number (Gearhead + Input)	Max. Input Speed RPM (n1)			Motor Shaft Max ϕ d_{MW}	Input Inertia J_1	Tors. Stiffness C_2
		Nom. ¹⁾ M_{2N}	Accel. M_{2acc}	Peak ²⁾ M_{2NOT}			Continuous		Cyclic			
Nom.	Exact	Nm	Nm	Nm	arcmin		EL 1,2,3,4	EL 5,6	All	mm	kgcm ²	Nm/arcmin

C0 (continued from previous page)

14.08	169/12	60	65	120	16	C002_0140 ME10	4000	4000	6500	≤ 19	0.8	1.6
						C002_0140 ME20	3700	3700	6000	≤ 24	2.7	
15.64	1595/102	60	72	120	16	C002_0155 ME10	4000	4000	6500	≤ 19	0.8	1.6
						C002_0155 ME20	3700	3700	6000	≤ 24	2.6	
17.53	3575/204	60	65	120	16	C002_0175 ME10	4000	4000	6500	≤ 19	0.8	1.6
						C002_0175 ME20	3700	3700	6000	≤ 24	2.6	
20.71	145/7	60	72	120	16	C002_0210 ME10	4000	4000	7000	≤ 19	0.7	1.6
						C002_0210 ME20	3700	3700	6000	≤ 24	2.6	
23.21	325/14	60	65	120	16	C002_0230 ME10	4000	4000	7000	≤ 19	0.7	1.6
						C002_0230 ME20	3700	3700	6000	≤ 24	2.6	
24.97	899/36	60	72	120	16	C002_0250 ME10	4000	4000	7000	≤ 19	0.7	1.6
						C002_0250 ME20	3700	3700	6000	≤ 24	2.6	
27.99	2015/72	60	65	120	16	C002_0280 ME10	4000	4000	7000	≤ 19	0.7	1.6
						C002_0280 ME20	3700	3700	6000	≤ 24	2.6	
31.26	2813/90	60	72	120	16	C002_0310 ME10	4000	4000	7000	≤ 19	0.7	1.6
						C002_0310 ME20	3700	3700	6000	≤ 24	2.6	
35.03	1261/36	60	65	120	16	C002_0350 ME10	4000	4000	7000	≤ 19	0.7	1.6
				120		C002_0350 ME20	3700	3700	6000	≤ 24	2.6	
41.77	3509/84	60	72	120	16	C002_0420 ME10	4000	4000	7000	≤ 19	0.6	1.6
46.82	7865/168	60	65	120	16	C002_0470 ME10	4000	4000	7000	≤ 19	0.6	1.6
49.94	899/18	60	72	120	16	C002_0500 ME10	4000	4000	7000	≤ 19	0.6	1.6
55.97	2015/36	60	65	120	16	C002_0560 ME10	4000	4000	7000	≤ 19	0.6	1.6
62.35	1247/20	60	72	120	16	C002_0620 ME10	4000	4000	7000	≤ 19	0.6	1.6
69.88	559/8	60	65	120	16	C002_0700 ME10	4000	4000	7000	≤ 19	0.6	1.6

C Series: INLINE — Shaft Output

¹⁾ Maximum torque for continuous input 1500 RPM - horizontal output position.

²⁾ Maximum momentary torque for emergency stops or heavy shock load. (Admissible stops per life of gearhead = 1,000 stops maximum.)

* Motor shaft adapter code (shaft diameter max - mm): ME10 (19), ME20 (32), ME30 (38), ME40 (48), ME50 (60)

C Series: INLINE – Shaft Output

Reducer Ratio (i)		Output Torque			Backlash $\Delta\phi_2$	Part Number (Gearhead + Input)	Max. Input Speed RPM (n1)			Motor Shaft Max ϕ d_{MW}	Input Inertia J_1	Tors. Stiffness C_2
		Nom. ¹⁾ M_{2N}	Accel. M_{2acc}	Peak ²⁾ M_{2NOT}			Continuous		Cyclic			
Nom.	Exact	Nm	Nm	Nm	arcmin		EL 1,2,3,4	EL 5,6	All	mm	kgcm ²	Nm/ arcmin

C1 (continued next page)

2.018	1128/559	47	47	59	18	C102_0020 ME10	3100	2600	5000	≤19	2.5	2.8
		70	100	150		C102_0020 ME20				≤32	5.9	3.0
						C102_0020 ME30				≤38	11.0	3.1
2.177	468/215	51	51	63	18	C102_0022 ME10	3100	2600	5000	≤19	2.5	2.8
		71	110	160		C102_0022 ME20				≤32	5.9	3.1
						C102_0022 ME30				≤38	11.0	
2.394	2303/962	74	110	170	18	C102_0024 ME20	3100	2600	5000	≤32	5.5	3.1
						C102_0024 ME30				≤38	11.0	
2.582	1911/740	75	110	190	18	C102_0026 ME20	3100	2600	5000	≤32	5.5	3.1
						C102_0026 ME30				≤38	11.0	
3.091	2491/806	63	72	90	18	C102_0031 ME10	3600	3100	6000	≤19	1.6	3.0
		80	120	220		C102_0031 ME20				≤32	5.0	3.1
						C102_0031 ME30	3500		5000	≤38	10.0	
3.334	2067/620	68	78	97	18	C102_0033 ME10	3600	3100	6000	≤19	1.6	3.0
		82	120	220		C102_0033 ME20				≤32	5.0	3.1
						C102_0033 ME30	3500		5000	≤38	10.0	
3.883	1363/351	69	90	110	18	C102_0039 ME10	3600	3100	6000	≤19	1.3	3.0
		86	130	220		C102_0039 ME20				≤32	4.8	3.1
						C102_0039 ME30	3500		5000	≤38	10.0	
4.189	377/90	74	98	120	18	C102_0042 ME10	3600	3100	6000	≤19	1.3	3.0
		89	130	220		C102_0042 ME20				≤32	4.7	3.1
						C102_0042 ME30	3500		5000	≤38	10.0	
4.658	3149/676	72	110	140	18	C102_0047 ME10	3800	3500	6000	≤19	1.2	3.1
		92	130	220		C102_0047 ME20				≤32	4.6	
						C102_0047 ME30	3500		5000	≤38	9.9	
5.025	201/40	77	120	150	18	C102_0050 ME10	3800	3500	6000	≤19	1.2	3.1
		94	130	220		C102_0050 ME20				≤32	4.6	
						C102_0050 ME30	3500		5000	≤38	9.9	
5.875	47/8	78	130	170	18	C102_0059 ME10	3800	3500	6000	≤19	1.0	3.1
		99		220		C102_0059 ME20				≤32	4.4	
							C102_0059 ME30		3500	5000	≤38	

¹⁾ Maximum torque for continuous input 1500 RPM - horizontal output position.

²⁾ Maximum momentary torque for emergency stops or heavy shock load. (Admissible stops per life of gearhead = 1,000 stops maximum.)

* Motor shaft adapter code (shaft diameter max - mm): ME10 (19), ME20 (32), ME30 (38), ME40 (48), ME50 (60)

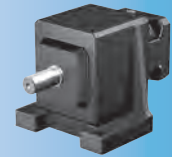

Selection Data

Reducer Ratio (i)		Output Torque			Backlash $\Delta\phi_2$	Part Number (Gearhead + Input)	Max. Input Speed RPM (n1)			Motor Shaft Max ϕ d_{MW}	Input Inertia J_1	Tors. Stiffness C_2
		Nom. ¹⁾ M_{2N}	Accel. M_{2acc}	Peak ²⁾ M_{2NOT}			Continuous		Cyclic			
Nom.	Exact	Nm	Nm	Nm	arcmin		EL 1,2,3,4	EL 5,6	All	mm	kgcm ²	Nm/arcmin

C1 (continued next page)

6.338	507/80	84	130	180	18	C102_0063 ME10	3800	3500	6000	≤19	1.0	3.1		
		100		220		C102_0063 ME20	3700			≤32	4.4			
						C102_0063 ME30	3500			5000	≤38		9.7	
7.796	3243/416	83	130	210	18	C102_0078 ME10	4000	3700	6500	≤19	0.9	3.1		
		110		220		C102_0078 ME20	3700			3700	6000		≤32	4.3
						C102_0078 ME30	3500			3500	5000		≤38	9.6
8.263	1537/186	120	140	240	15	C102_0083 ME10	3600	3100	6000	≤19	1.4	3.9		
						C102_0083 ME20				≤32	4.8			
						C102_0083 ME30	3500			5000	≤38		10.0	
9.326	3180/341	120	140	240	15	C102_0093 ME10	3600	3100	6000	≤19	1.3	3.9		
						C102_0093 ME20				≤32	4.7			
						C102_0093 ME30	3500			5000	≤38		10.0	
10.38	841/81	120	140	240	15	C102_0105 ME10	3600	3100	6000	≤19	1.2	3.9		
						C102_0105 ME20				≤32	4.6			
						C102_0105 ME30	3500			5000	≤38		9.9	
11.72	1160/99	120	140	240	15	C102_0115 ME10	3600	3100	6000	≤19	1.2	3.9		
						C102_0115 ME20				≤32	4.6			
						C102_0115 ME30	3500			5000	≤38		9.9	
12.46	1943/156	120	140	240	15	C102_0125 ME10	3800	3500	6000	≤19	1.0	3.9		
						C102_0125 ME20	3700			≤32	4.5			
						C102_0125 ME30	3500			5000	≤38		9.8	
14.06	2010/143	120	140	240	15	C102_0140 ME10	3800	3500	6000	≤19	1.0	3.9		
						C102_0140 ME20	3700			≤32	4.4			
						C102_0140 ME30	3500			5000	≤38		9.8	
15.71	377/24	120	140	240	15	C102_0155 ME10	3800	3500	6000	≤19	0.9	3.9		
						C102_0155 ME20	3700			≤32	4.3			
						C102_0155 ME30	3500			5000	≤38		9.7	
17.73	195/11	120	140	240	15	C102_0175 ME10	3800	3500	6000	≤19	0.9	3.9		
						C102_0175 ME20	3700			≤32	4.3			
						C102_0175 ME30	3500			5000	≤38		9.7	
20.84	667/32	120	140	240	15	C102_0210 ME10	4000	3900	6500	≤19	0.8	3.9		
						C102_0210 ME20	3700			3700	6000		≤32	4.2
						C102_0210 ME30	3500			3500	5000		≤38	9.6

C Series: INLINE — Shaft Output

¹⁾ Maximum torque for continuous input 1500 RPM - horizontal output position.

²⁾ Maximum momentary torque for emergency stops or heavy shock load. (Admissible stops per life of gearhead = 1,000 stops maximum.)

* Motor shaft adapter code (shaft diameter max - mm): ME10 (19), ME20 (32), ME30 (38), ME40 (48), ME50 (60)

C Series: INLINE – Shaft Output

Reducer Ratio (i)		Output Torque			Backlash $\Delta\phi_2$	Part Number (Gearhead + Input)	Max. Input Speed RPM (n1)			Motor Shaft Max ϕ d_{MW}	Input Inertia J_1	Tors. Stiffness C_2
		Nom. ¹⁾ M_{2N}	Accel. M_{2acc}	Peak ²⁾ M_{2NOT}			Continuous		Cyclic			
Nom.	Exact	Nm	Nm	Nm	arcmin		EL 1,2,3,4	EL 5,6	All	mm	kgcm ²	Nm/ arcmin

C1 (continued from previous page)

23.52	1035/44	120	140	240	15	C102_0240 ME10	4000	3900	6500	≤19	0.8	3.9
						C102_0240 ME20	3700	3700	6000	≤32	4.2	
						C102_0240 ME30	3500	3500	5000	≤38	9.6	
25.13	377/15	120	140	240	15	C102_0250 ME10	4000	3900	6500	≤19	0.8	3.9
						C102_0250 ME20	3700	3700	6000	≤24	2.7	
28.36	312/11	120	140	240	15	C102_0280 ME10	4000	3900	6500	≤19	0.8	3.9
						C102_0280 ME20	3700	3700	6000	≤24	2.7	
31.07	435/14	120	140	240	15	C102_0310 ME10	4000	3900	6500	≤19	0.7	3.9
						C102_0310 ME20	3700	3700	6000	≤24	2.6	
35.07	2700/77	120	140	240	15	C102_0350 ME10	4000	3900	6500	≤19	0.7	3.9
						C102_0350 ME20	3700	3700	6000	≤24	2.6	
41.57	1247/30	120	140	240	15	C102_0420 ME10	4000	3900	6500	≤19	0.7	3.9
						C102_0420 ME20	3700	3700	6000	≤24	2.6	
46.91	516/11	120	140	240	15	C102_0470 ME10	4000	3900	6500	≤19	0.7	3.9
						C102_0470 ME20	3700	3700	6000	≤24	2.6	
49.94	899/18	120	140	240	15	C102_0500 ME10	4000	3900	6500	≤19	0.7	3.9
56.36	620/11	120	140	240	15	C102_0560 ME10	4000	3900	6500	≤19	0.7	3.9
62.43	4495/72	120	140	240	15	C102_0620 ME10	4000	3900	6500	≤19	0.6	3.9
70.46	775/11	120	140	240	15	C102_0700 ME10	4000	3900	6500	≤19	0.6	3.9
81.64	31,349/384	120	140	240	15	C103_0820 ME10	4000	3900	6500	≤19	0.7	3.9
92.13	16,215/176	120	140	240	15	C103_0920 ME10	4000	3900	6500	≤19	0.7	3.9
111.1	1222/11	120	140	240	15	C103_1110 ME10	4000	3900	6500	≤19	0.7	3.9
137.3	10,575/77	120	140	240	15	C103_1370 ME10	4000	3900	6500	≤19	0.7	3.9
183.7	2021/11	120	140	240	15	C103_1840 ME10	4000	3900	6500	≤19	0.7	3.9
220.8	7285/33	120	140	240	15	C103_2210 ME10	4000	3900	6500	≤19	0.7	3.9
275.9	36,425/132	120	140	240	15	C103_2760 ME10	4000	3900	6500	≤19	0.7	3.9

¹⁾ Maximum torque for continuous input 1500 RPM - horizontal output position.

²⁾ Maximum momentary torque for emergency stops or heavy shock load. (Admissible stops per life of gearhead = 1,000 stops maximum.)

* Motor shaft adapter code (shaft diameter max - mm): ME10 (19), ME20 (32), ME30 (38), ME40 (48), ME50 (60)



Selection Data

Reducer Ratio (i)		Output Torque			Backlash $\Delta\phi_2$	Part Number (Gearhead + Input)	Max. Input Speed RPM (n1)			Motor Shaft Max ϕ d_{MW}	Input Inertia J_1	Tors. Stiffness C_2
		Nom. ¹⁾ M_{2N}	Accel. M_{2acc}	Peak ²⁾ M_{2NOT}			Continuous		Cyclic			
Nom.	Exact	Nm	Nm	Nm	arcmin		EL 1,2,3,4	EL 5,6	All	mm	kgcm ²	Nm/arcmin

C2 (continued next page)

2.009	432/215	110	120	150	17	C202_0020 ME20	3000	2600	4500	≤ 32	7.9	5.7
			160	350		C202_0020 ME30				≤ 38	13.0	5.9
2.184	2160/989	110	130	160	17	C202_0022 ME20	3000	2600	4500	≤ 32	7.8	5.7
			160	350		C202_0022 ME30				≤ 38	13.0	5.9
2.475	99/40	110	140	180	17	C202_0025 ME20	3000	2600	4500	≤ 32	6.9	5.8
						C202_0025 ME30				≤ 38	12.0	5.9
2.690	495/184	120	160	200	17	C202_0027 ME20	3000	2600	4500	≤ 32	6.8	5.8
						C202_0027 ME30				≤ 38	12.0	5.9
3.103	90/29	120	180	230	17	C202_0031 ME20	3500	3100	5000	≤ 32	6.1	5.9
						C202_0031 ME30				≤ 38	11.0	
3.373	2250/667	130	190	250	17	C202_0034 ME20	3500	3100	5000	≤ 32	6.0	5.9
						C202_0034 ME30				≤ 38	11.0	
3.888	486/125	78	91	110	17	C202_0039 ME10	3500	3100	5000	≤ 19	2.1	5.6
		130	200	280		C202_0039 ME20				≤ 32	5.5	5.9
						C202_0039 ME30				≤ 38	11.0	6.0
4.226	486/115	85	98	120	17	C202_0042 ME10	3500	3100	5000	≤ 19	2.1	5.7
		140	200	310		C202_0042 ME20				≤ 32	5.5	5.9
						C202_0042 ME30				≤ 38	11.0	6.0
4.667	14/3	81	110	140	17	C202_0047 ME10	3700	3500	5500	≤ 19	1.7	5.8
		140	200	340		C202_0047 ME20				≤ 32	5.1	6.0
						C202_0047 ME30	3500	5000	≤ 38	10.0		
5.072	350/69	88	120	150	17	C202_0051 ME10	3700	3500	5500	≤ 19	1.7	5.8
		140	200	350		C202_0051 ME20				≤ 32	5.1	6.0
						C202_0051 ME30	3500	5000	≤ 38	10.0		
5.791	666/115	86	130	170	17	C202_0058 ME10	3700	3500	5500	≤ 19	1.4	5.8
		150	200	350		C202_0058 ME20				≤ 32	4.8	6.0
						C202_0058 ME30	3500	5000	≤ 38	10.0		
6.295	3330/529	93	150	180	17	C202_0063 ME10	3700	3500	5500	≤ 19	1.4	5.9
		160	200	350		C202_0063 ME20				≤ 32	4.8	6.0
						C202_0063 ME30	3500	5000	≤ 38	10.0		
7.800	39/5	91	170	220	17	C202_0078 ME10	4000	3900	6500	≤ 19	1.1	5.9
		170	200	350		C202_0078 ME20	3700	3700	6000	≤ 32	4.5	6.0
						C202_0078 ME30	3500	3500	5000	≤ 38	9.9	

C Series: INLINE — Shaft Output

¹⁾ Maximum torque for continuous input 1500 RPM - horizontal output position.

²⁾ Maximum momentary torque for emergency stops or heavy shock load. (Admissible stops per life of gearhead = 1,000 stops maximum.)

* Motor shaft adapter code (shaft diameter max - mm): ME10 (19), ME20 (32), ME30 (38), ME40 (48), ME50 (60)

C Series: INLINE – Shaft Output

Reducer Ratio (i)		Output Torque			Backlash $\Delta\phi_2$	Part Number (Gearhead + Input)	Max. Input Speed RPM (n1)			Motor Shaft Max ϕ d_{MW}	Input Inertia J_1	Tors. Stiffness C_2
		Nom. ¹⁾ M_{2N}	Accel. M_{2acc}	Peak ²⁾ M_{2NOT}			Continuous		Cyclic			
Nom.	Exact	Nm	Nm	Nm	arcmin		EL 1,2,3,4	EL 5,6	All	mm	kgcm ²	Nm/ arcmin

C2 (continued next page)

8.190	475/58	200	230	400	14	C202_0082 ME20	3500	3100	5000	≤32	5.6	8.3
						C202_0082 ME30				≤38	11.0	
9.387	2450/261	200	230	400	14	C202_0094 ME20	3500	3100	5000	≤32	5.5	8.3
						C202_0094 ME30				≤38	11.0	
10.26	513/50	200	230	300	14	C202_0105 ME10	3500	3100	5000	≤19	1.8	8.2
				400		C202_0105 ME20				≤32	5.2	
						C202_0105 ME30				≤38	10.0	
11.76	294/25	200	230	340	14	C202_0120 ME10	3500	3100	5000	≤19	1.7	8.2
				400		C202_0120 ME20				≤32	5.2	
						C202_0120 ME30				≤38	10.0	
12.32	665/54	200	230	360	14	C202_0125 ME10	3700	3500	5500	≤19	1.5	8.2
				400		C202_0125 ME20				≤32	4.9	
						C202_0125 ME30	3500	5000	≤38	10.0	8.3	
14.12	3430/243	200	230	400	14	C202_0140 ME10	3700	3500	5500	≤19	1.5	8.2
						C202_0140 ME20				≤32	4.9	
							C202_0140 ME30	3500	5000	≤38	10.0	8.3
15.28	703/46	200	230	400	14	C202_0155 ME10	3700	3500	5500	≤19	1.3	8.2
						C202_0155 ME20				≤32	4.7	
							C202_0155 ME30	3500	5000	≤38	10.0	8.3
17.52	3626/207	200	230	400	14	C202_0175 ME10	3700	3500	5500	≤19	1.3	8.3
						C202_0175 ME20				≤32	4.7	
							C202_0175 ME30	3500	5000	≤38	10.0	
20.58	247/12	200	230	400	14	C202_0210 ME10	4000	3900	6500	≤19	1.1	8.3
						C202_0210 ME20	3700	3700	6000	≤32	4.5	
						C202_0210 ME30	3500	3500	5000	≤38	9.8	
23.59	637/27	200	230	400	14	C202_0240 ME10	4000	3900	6500	≤19	1.0	8.3
						C202_0240 ME20	3700	3700	6000	≤32	4.5	
						C202_0240 ME30	3500	3500	5000	≤38	9.8	
24.64	1577/64	200	230	400	14	C202_0250 ME10	4000	3900	6500	≤19	1.0	8.3
						C202_0250 ME20	3700	3700	6000	≤32	4.4	
						C202_0250 ME30	3500	3500	5000	≤38	9.7	

¹⁾ Maximum torque for continuous input 1500 RPM - horizontal output position.

²⁾ Maximum momentary torque for emergency stops or heavy shock load. (Admissible stops per life of gearhead = 1,000 stops maximum.)

* Motor shaft adapter code (shaft diameter max - mm): ME10 (19), ME20 (32), ME30 (38), ME40 (48), ME50 (60)

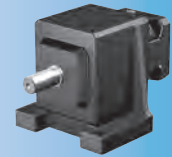

Selection Data

Reducer Ratio (i)		Output Torque			Backlash $\Delta\phi_2$	Part Number (Gearhead + Input)	Max. Input Speed RPM (n1)			Motor Shaft Max ϕ d_{MW}	Input Inertia J_1	Tors. Stiffness C_2
		Nom. ¹⁾ M_{2N}	Accel. M_{2acc}	Peak ²⁾ M_{2NOT}			Continuous		Cyclic			
Nom.	Exact	Nm	Nm	Nm	arcmin		EL 1,2,3,4	EL 5,6	All	mm	kgcm ²	Nm/arcmin

C2 (continued from previous page)

28.24	4067/144	200	230	400	14	C202_0280 ME10	4000	3900	6500	≤19	1.0	8.3
						C202_0280 ME20	3700	3700	6000	≤32	4.4	
						C202_0280 ME30	3500	3500	5000	≤38	9.7	
30.69	399/13	200	230	400	14	C202_0310 ME10	4000	3900	6500	≤19	0.9	8.3
						C202_0310 ME20	3700	3700	6000	≤24	2.8	
						C202_0310 ME30	3500	3500	5000	≤32	7.9	
35.18	1372/39	200	230	400	14	C202_0350 ME10	4000	3900	6500	≤19	0.9	8.3
						C202_0350 ME20	3700	3700	6000	≤24	2.8	
40.85	817/20	200	230	400	14	C202_0410 ME10	4000	3900	6500	≤19	0.8	8.3
						C202_0410 ME20	3700	3700	6000	≤24	2.7	
46.82	2107/45	200	230	400	14	C202_0470 ME10	4000	3900	6500	≤19	0.8	8.3
						C202_0470 ME20	3700	3700	6000	≤24	2.7	
49.23	1083/22	200	230	400	14	C202_0490 ME10	4000	3900	6500	≤19	0.7	8.3
						C202_0490 ME20	3700	3700	6000	≤24	2.6	
56.42	1862/33	200	230	400	14	C202_0560 ME10	4000	3900	6500	≤19	0.7	8.3
						C202_0560 ME20	3700	3700	6000	≤24	2.6	
61.35	2945/48	190	220	270	14	C202_0610 ME10	4000	3900	6500	≤19	0.7	8.3
70.32	7595/108	200	230	310	14	C202_0700 ME10	4000	3900	6500	≤19	0.7	8.3
79.59	7163/90	200	230	400	14	C203_0800 ME20	3700	3700	6000	≤24	2.7	8.3
80.62	11,609/144	200	230	400	14	C203_0810 ME10	4000	3900	6500	≤19	0.7	8.3
91.23	36,946/405	200	230	400	14	C203_0910 ME20	3700	3700	6000	≤24	2.7	8.3
92.4	29,939/324	200	230	400	14	C203_0920 ME10	4000	3900	6500	≤19	0.7	8.3
109.2	117,943/1080	200	230	400	14	C203_1090 ME20	3700	3700	6000	≤24	2.7	8.3
110.6	191,149/1728	200	230	400	14	C203_1110 ME10	4000	3900	6500	≤19	0.7	8.3
136.0	79,576/585	200	230	400	14	C203_1360 ME20	3700	3700	6000	≤24	2.7	8.3
137.8	16,121/117	200	230	400	14	C203_1380 ME10	4000	3900	6500	≤19	0.7	8.3
181.0	122,206/675	200	230	400	14	C203_1810 ME20	3700	3700	6000	≤24	2.7	8.3
183.4	99,029/540	200	230	400	14	C203_1830 ME10	4000	3900	6500	≤19	0.7	8.3
221.0	43,757/198	200	230	400	14	C203_2210 ME10	4000	3900	6500	≤19	0.7	8.3
275.4	356,965/1296	200	230	310	14	C203_2750 ME10	4000	3900	6500	≤19	0.7	8.3

C Series: INLINE – Shaft Output

¹⁾ Maximum torque for continuous input 1500 RPM - horizontal output position.

²⁾ Maximum momentary torque for emergency stops or heavy shock load. (Admissible stops per life of gearhead = 1,000 stops maximum.)

* Motor shaft adapter code (shaft diameter max - mm): ME10 (19), ME20 (32), ME30 (38), ME40 (48), ME50 (60)

C Series: INLINE – Shaft Output

Reducer Ratio (i)		Output Torque			Backlash $\Delta\phi_2$	Part Number (Gearhead + Input)	Max. Input Speed RPM (n1)			Motor Shaft Max ϕ d_{MW}	Input Inertia J_1	Tors. Stiffness C_2
		Nom. ¹⁾ M_{2N}	Accel. M_{2acc}	Peak ²⁾ M_{2NOT}			Continuous		Cyclic			
Nom.	Exact	Nm	Nm	Nm	arcmin		EL 1,2,3,4	EL 5,6	All	mm	kgcm ²	Nm/ arcmin

C3 (continued next page)

2.020	608/301	170	260	390	16	C302_0020 ME30	2700	2300	4000	≤38	16.0	6.9	
						C302_0020 ME40				≤48	38.0		
2.177	468/215	180	270	420	16	C302_0022 ME30	2700	2300	4000	≤38	16.0	6.9	
						C302_0022 ME40				≤48	38.0		
2.510	1634/651	190	280	490	16	C302_0025 ME30	2700	2300	4000	≤38	15.0	7.0	
						C302_0025 ME40				≤48	36.0	6.9	
2.705	1677/620	190	290	520	16	C302_0027 ME30	2700	2300	4000	≤38	14.0	7.0	
						C302_0027 ME40				≤48	36.0		
3.110	1045/336	180	180	230	16	C302_0031 ME20	3200	2800	4800	≤32	7.7	6.9	
		200	300	550		C302_0031 ME30				≤38	13.0		
						C302_0031 ME40				3000	4500		≤48
3.352	429/128	200	200	240	16	C302_0034 ME20	3200	2800	4800	≤32	7.5	6.9	
		210	310	550		C302_0034 ME30				≤38	13.0		
						C302_0034 ME40				3000	4500		≤48
3.878	190/49	200	230	280	16	C302_0039 ME20	3200	2800	4800	≤32	6.6	6.9	
		220	320	550		C302_0039 ME30				≤38	12.0		
						C302_0039 ME40				3000	4500		≤48
4.179	117/28	220	240	300	16	C302_0042 ME20	3200	2800	4800	≤32	6.6	7.0	
			330	550		C302_0042 ME30				≤38	12.0		
						C302_0042 ME40				3000	4500		≤48
4.675	589/126	210	270	340	16	C302_0047 ME20	3500	3100	5500	≤32	6.0	7.0	
		230	330	550		C302_0047 ME30				5000	≤38		11.0
						C302_0047 ME40				3000	3000		4500
5.038	403/80	230	290	370	16	C302_0050 ME20	3500	3100	5500	≤32	6.0	7.0	
		240	330	550		C302_0050 ME30				5000	≤38		11.0
						C302_0050 ME40				3000	3000		4500
5.859	2584/441	230	320	400	16	C302_0059 ME20	3500	3100	5500	≤32	5.4	7.0	
		250	330	550		C302_0059 ME30				5000	≤38		11.0
						C302_0059 ME40				3000	3000		4500
6.314	221/35	250	330	430	16	C302_0063 ME20	3500	3100	5500	≤32	5.4	7.0	
				550		C302_0063 ME30				5000	≤38	11.0	7.1
						C302_0063 ME40				3000	3000	4500	≤48

¹⁾ Maximum torque for continuous input 1500 RPM - horizontal output position.

²⁾ Maximum momentary torque for emergency stops or heavy shock load. (Admissible stops per life of gearhead = 1,000 stops maximum.)

* Motor shaft adapter code (shaft diameter max - mm): ME10 (19), ME20 (32), ME30 (38), ME40 (48), ME50 (60)

Selection Data



Reducer Ratio (i)		Output Torque			Backlash $\Delta\phi_2$	Part Number (Gearhead + Input)	Max. Input Speed RPM (n1)			Motor Shaft Max ϕ d_{MW}	Input Inertia J_1	Tors. Stiffness C_2
		Nom. ¹⁾ M_{2N}	Accel. M_{2acc}	Peak ²⁾ M_{2NOT}			Continuous		Cyclic			
Nom.	Exact	Nm	Nm	Nm	arcmin		EL 1,2,3,4	EL 5,6	All	mm	kgcm ²	Nm/arcmin

C3 (continued next page)

7.841	494/63	240	330	470	16	C302_0078 ME20	3700	3500	6000	≤32	4.9	7.0
		270		550		C302_0078 ME30	3500	3500	5000	≤38	10.0	7.1
				C302_0078 ME40		3000	3000	4500	≤48	32.0		
8.250	33/4	340	400	600	13	C302_0083 ME20	3200	2800	4800	≤32	6.6	8.7
				700		C302_0083 ME30			4800	≤38	12.0	
				C302_0083 ME40		3000	4500	≤48	34.0			
9.310	3575/384	350	350	680	13	C302_0093 ME20	3200	2800	4800	≤32	6.6	8.7
				700		C302_0093 ME30			4800	≤38	12.0	
				C302_0093 ME40		3000	4500	≤48	34.0			
10.29	72/7	350	400	700	13	C302_0105 ME20	3200	2800	4800	≤32	6.0	8.7
						C302_0105 ME30			4800	≤38	11.0	
						C302_0105 ME40	3000	4500	≤48	33.0		
11.61	325/28	350	350	700	13	C302_0115 ME20	3200	2800	4800	≤32	5.9	8.7
						C302_0115 ME30			4800	≤38	11.0	
						C302_0115 ME40	3000	4500	≤48	33.0		
12.40	62/5	350	400	700	13	C302_0125 ME20	3500	3100	5500	≤32	5.6	8.7
						C302_0125 ME30			5000	≤38	11.0	
						C302_0125 ME40	3000	3000	4500	≤48	33.0	
13.99	2015/144	350	350	700	13	C302_0140 ME20	3500	3100	5500	≤32	5.5	8.7
						C302_0140 ME30			5000	≤38	11.0	
						C302_0140 ME40	3000	3000	4500	≤48	33.0	
15.54	544/35	350	400	700	13	C302_0155 ME20	3500	3100	5500	≤32	5.1	8.7
						C302_0155 ME30			5000	≤38	11.0	
						C302_0155 ME40	3000	3000	4500	≤48	33.0	
17.54	1105/63	350	350	700	13	C302_0175 ME20	3500	3100	5500	≤32	5.1	8.7
						C302_0175 ME30			5000	≤38	11.0	
						C302_0175 ME40	3000	3000	4500	≤48	32.0	
20.80	104/5	350	400	700	13	C302_0210 ME20	3700	3500	6000	≤32	4.7	8.7
						C302_0210 ME30			5000	≤38	10.0	
						C302_0210 ME40	3000	3000	4500	≤48	32.0	
23.47	845/36	350	350	700	13	C302_0230 ME20	3700	3500	6000	≤32	4.7	8.7
						C302_0230 ME30			5000	≤38	10.0	
						C302_0230 ME40	3000	3000	4500	≤48	32.0	

C Series: INLINE — Shaft Output

¹⁾ Maximum torque for continuous input 1500 RPM - horizontal output position.

²⁾ Maximum momentary torque for emergency stops or heavy shock load. (Admissible stops per life of gearhead = 1,000 stops maximum.)

* Motor shaft adapter code (shaft diameter max - mm): ME10 (19), ME20 (32), ME30 (38), ME40 (48), ME50 (60)

C Series: INLINE – Shaft Output

Reducer Ratio (i)		Output Torque			Backlash $\Delta\phi_2$	Part Number (Gearhead + Input)	Max. Input Speed RPM (n1)			Motor Shaft Max ϕ d _{MW}	Input Inertia J ₁	Tors. Stiffness C ₂
		Nom. ¹⁾ M _{2N}	Accel. M _{2acc}	Peak ²⁾ M _{2NOT}			Continuous		Cyclic			
Nom.	Exact	Nm	Nm	Nm	arcmin	EL 1,2,3,4	EL 5,6	All	mm	kgcm ²	Nm/ arcmin	

C3 (continued from previous page)

24.80	124/5	350	400	700	13	C302_0250 ME20	3700	3500	6000	≤32	4.6	8.7
						C302_0250 ME30	3500		5000	≤38	9.9	
27.99	2015/72	350	350	700	13	C302_0280 ME20	3700	3500	6000	≤32	4.6	8.7
						C302_0280 ME30	3500		5000	≤38	9.9	
31.04	776/25	350	400	700	13	C302_0310 ME20	3700	3500	6000	≤32	4.4	8.7
						C302_0310 ME30	3500		5000	≤38	9.7	
35.03	1261/36	350	350	700	13	C302_0350 ME20	3700	3500	6000	≤32	4.4	8.7
						C302_0350 ME30	3500		5000	≤38	9.7	
41.35	2688/65	350	400	700	13	C302_0410 ME20	3700	3500	6000	≤24	2.8	8.7
46.67	140/3	350	350	700	13	C302_0470 ME20	3700	3500	6000	≤24	2.8	8.7
49.75	2736/55	350	400	700	13	C302_0500 ME20	3700	3500	6000	≤24	2.7	8.7
56.14	1235/22	350	350	700	13	C302_0560 ME20	3700	3500	6000	≤24	2.7	8.7
61.92	1548/25	330	400	660	13	C302_0620 ME20	3700	3500	6000	≤24	2.6	8.7
69.88	559/8	350	350	700	13	C302_0700 ME20	3700	3500	6000	≤24	2.6	8.7
80.43	6032/75	350	400	700	13	C303_0800 ME20	3700	3500	6000	≤24	2.7	8.7
81.47	1222/15	350	400	520	13	C303_0810 ME10	3800	3500	6000	≤19	0.7	8.7
90.76	4901/54	350	350	700	13	C303_0910 ME20	3700	3500	6000	≤24	2.7	8.7
91.93	39,715/432	350	350	590	13	C303_0920 ME10	3800	3500	6000	≤19	0.7	8.7
108.2	11,687/108	350	350	700	13	C303_1080 ME20	3700	3500	6000	≤24	2.7	8.7
109.6	94,705/864	350	350	700	13	C303_1100 ME10	3800	3500	6000	≤19	0.7	8.7
135.4	36,569/270	350	350	700	13	C303_1350 ME20	3700	3500	6000	≤24	2.7	8.7
137.2	59,267/432	350	350	700	13	C303_1370 ME10	3800	3500	6000	≤19	0.7	8.7
180.4	1624/9	350	350	700	13	C303_1800 ME20	3700	3500	6000	≤24	2.7	8.7
182.8	1645/9	350	350	700	13	C303_1830 ME10	3800	3500	6000	≤19	0.7	8.7
217.1	7163/33	350	350	700	13	C303_2170 ME20	3700	3500	6000	≤24	2.7	8.7
219.9	58,045/264	350	350	700	13	C303_2200 ME10	3800	3500	6000	≤19	0.7	8.7
273.7	26273/96	350	350	700	13	C303_2740 ME10	3800	3500	6000	≤19	0.7	8.7

¹⁾ Maximum torque for continuous input 1500 RPM - horizontal output position.

²⁾ Maximum momentary torque for emergency stops or heavy shock load. (Admissible stops per life of gearhead = 1,000 stops maximum.)

* Motor shaft adapter code (shaft diameter max - mm): ME10 (19), ME20 (32), ME30 (38), ME40 (48), ME50 (60)

Selection Data

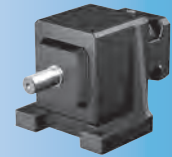

Reducer Ratio (i)		Output Torque			Backlash $\Delta\phi_2$	Part Number (Gearhead + Input)	Max. Input Speed RPM (n1)			Motor Shaft Max ϕ d_{MW}	Input Inertia J_1	Tors. Stiffness C_2
		Nom. ¹⁾ M_{2N}	Accel. M_{2acc}	Peak ²⁾ M_{2NOT}			Continuous	Cyclic				
Nom.	Exact	Nm	Nm	Nm	arcmin		EL 1,2,3,4	EL 5,6	All	mm	kgcm ²	Nm/arcmin

C4 (continued next page)

1.968	551/280	250	310	380	15	C402_0020 ME30	2500	2100	3500	≤38	27.0	16.0	
						C402_0020 ME40				≤48	48.0		
2.456	609/248	270	380	480	15	C402_0025 ME30	2500	2100	3500	≤38	22.0	16.0	
						C402_0025 ME40				≤48	44.0		
3.099	1537/496	290	440	600	15	C402_0031 ME30	2900	2500	4500	≤38	18.0	17.0	
						C402_0031 ME40				≤48	40.0		
3.894	841/216	230	230	280	15	C402_0039 ME20	2900	2500	4500	≤32	10.0	16.0	
		310	470	710		C402_0039 ME30				≤38	16.0		
						C402_0039 ME40				≤48	37.0		
4.682	899/192	240	270	340	15	C402_0047 ME20	3300	2800	5000	≤32	8.6	17.0	
						C402_0047 ME30				≤38	14.0		
		330	500	800		C402_0047 ME40	3000	4500	≤48	36.0			
5.891	377/64	260	320	400	15	C402_0059 ME20	3300	2800	5000	≤32	7.3	17.0	
		360	540	850		C402_0059 ME30				≤38	13.0		
						C402_0059 ME40	3000	4500	≤48	35.0			
7.816	2001/256	270	360	450	15	C402_0078 ME20	3500	3200	5500	≤32	6.1	17.0	
		400	550	850		C402_0078 ME30				≤38	12.0		
						C402_0078 ME40	3000	3000	4500	≤48	33.0		
8.285	3339/403	550	600	1100	12	C402_0083 ME30	2900	2500	4500	≤38	15.0	22.0	
						C402_0083 ME40				≤48	37.0		
9.261	3445/372	550	550	1100	12	C402_0093 ME30	2900	2500	4500	≤38	15.0	22.0	
						C402_0093 ME40				≤48	37.0		
10.41	406/39	550	600	760	12	C402_0105 ME20	2900	2500	4500	≤32	8.4	22.0	
				1100		C402_0105 ME30				≤38	14.0		
						C402_0105 ME40				≤48	36.0		
11.64	1885/162	550	550	850	12	C402_0115 ME20	2900	2500	4500	≤32	8.3	22.0	
										C402_0115 ME30	≤38		14.0
										C402_0115 ME40	≤48		36.0
12.52	651/52	550	600	910	12	C402_0125 ME20	3300	2800	5000	≤32	7.5	22.0	
				1100		C402_0125 ME30				≤38	13.0		
							C402_0125 ME40	3000	4500	≤48	35.0		
13.99	2015/144	550	550	1020	12	C402_0140 ME20	3300	2800	5000	≤32	7.4	22.0	
				1100		C402_0140 ME30				≤38	13.0		
							C402_0140 ME40	3000	4500	≤48	35.0		

C Series: INLINE — Shaft Output

¹⁾ Maximum torque for continuous input 1500 RPM - horizontal output position.

²⁾ Maximum momentary torque for emergency stops or heavy shock load. (Admissible stops per life of gearhead = 1,000 stops maximum.)

* Motor shaft adapter code (shaft diameter max - mm): ME10 (19), ME20 (32), ME30 (38), ME40 (48), ME50 (60)

C Series: INLINE – Shaft Output

Reducer Ratio (i)		Output Torque			Backlash $\Delta\phi_2$	Part Number (Gearhead + Input)	Max. Input Speed RPM (n1)			Motor Shaft Max ϕ d_{MW}	Input Inertia J_1	Tors. Stiffness C_2
		Nom. ¹⁾ M_{2N}	Accel. M_{2acc}	Peak ²⁾ M_{2NOT}			Continuous		Cyclic			
Nom.	Exact	Nm	Nm	Nm	arcmin	EL 1,2,3,4	EL 5,6	All	mm	kgcm ²	Nm/ arcmin	

C4 (continued from previous page)

15.75	63/4	550	600	1070	12	C402_0160 ME20	3300	2800	5000	≤32	6.6	22.0		
				1100		C402_0160 ME30			4500	≤38	12.0			
						C402_0160 ME40			3000	4500	≤48		34.0	
17.60	845/48	550	550	1100	12	C402_0175 ME20	3300	2800	5000	≤32	6.5	22.0		
									C402_0175 ME30		≤38		12.0	
									C402_0175 ME40	3000	4500		≤48	34.0
20.90	4347/208	550	600	1100	12	C402_0210 ME20	3500	3200	5500	≤32	5.7	22.0		
									C402_0210 ME30		5000		≤38	11.0
									C402_0210 ME40	3000	3000		4500	≤48
23.36	1495/64	550	550	1100	12	C402_0230 ME20	3500	3200	5500	≤32	5.7	22.0		
									C402_0230 ME30		5000		≤38	11.0
									C402_0230 ME40	3000	3000		4500	≤48
24.92	324/13	550	600	1100	12	C402_0250 ME20	3500	3200	5500	≤32	5.3	22.0		
									C402_0250 ME30		5000		≤38	11.0
27.86	195/7	550	550	1100	12	C402_0280 ME20	3500	3200	5500	≤32	5.3	22.0		
									C402_0280 ME30		5000		≤38	11.0
31.15	405/13	550	600	1100	12	C402_0310 ME20	3500	3200	5500	≤32	4.9	22.0		
									C402_0310 ME30		5000		≤38	10.0
34.82	975/28	550	550	1100	12	C402_0350 ME20	3500	3200	5500	≤32	4.9	22.0		
									C402_0350 ME30		5000		≤38	10.0
41.75	7056/169	550	600	1100	12	C402_0420 ME20	3500	3200	5500	≤32	4.6	22.0		
									C402_0420 ME30		5000		≤38	9.9
46.67	140/3	550	550	1100	12	C402_0470 ME20	3500	3200	5500	≤32	4.6	22.0		
									C402_0470 ME30		5000		≤38	9.9
50.19	1305/26	550	600	930	12	C402_0500 ME20	3500	3200	5500	≤24	2.9	22.0		
56.10	9425/168	550	550	1040	12	C402_0560 ME20	3500	3200	5500	≤24	2.9	22.0		
62.52	8127/130	500	600	960	12	C402_0630 ME20	3500	3200	5500	≤24	2.8	22.0		
69.88	559/8	550	550	1070	12	C402_0700 ME20	3500	3200	5500	≤24	2.8	22.0		
80.81	42,021/520	550	600	1100	12	C403_0810 ME20	3500	3200	5500	≤24	2.8	22.0		
90.32	8671/96	550	550	1100	12	C403_0900 ME20	3500	3200	5500	≤24	2.8	22.0		
107.7	754/7	550	550	1100	12	C403_1080 ME20	3500	3200	5500	≤24	2.8	22.0		
134.6	1885/14	550	550	1100	12	C403_1350 ME20	3500	3200	5500	≤24	2.8	22.0		
180.4	1624/9	550	550	1100	12	C403_1800 ME20	3500	3200	5500	≤24	2.7	22.0		
216.9	54,665/252	550	550	1040	12	C403_2170 ME20	3500	3200	5500	≤24	2.7	22.0		
270.2	16,211/60	550	550	1070	12	C403_2700 ME20	3500	3200	5500	≤24	2.7	22.0		

¹⁾ Maximum torque for continuous input 1500 RPM - horizontal output position.

²⁾ Maximum momentary torque for emergency stops or heavy shock load. (Admissible stops per life of gearhead = 1,000 stops maximum.)

* Motor shaft adapter code (shaft diameter max - mm): ME10 (19), ME20 (32), ME30 (38), ME40 (48), ME50 (60)

Selection Data

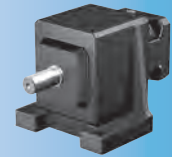

Reducer Ratio (i)		Output Torque			Backlash $\Delta\phi_2$	Part Number (Gearhead + Input)	Max. Input Speed RPM (n1)			Motor Shaft Max ϕ d_{MW}	Input Inertia J_1	Tors. Stiffness C_2
		Nom. ¹⁾ M_{2N}	Accel. M_{2acc}	Peak ²⁾ M_{2NOT}			Continuous		Cyclic			
Nom.	Exact	Nm	Nm	Nm	arcmin		EL 1,2,3,4	EL 5,6	All	mm	kgcm ²	Nm/arcmin

C5 (continued next page)

1.976	81/41	290	310	380	14	C502_0020 ME30	2400	2000	3200	≤38	40.0	20.0
						C502_0020 ME40				≤48	62.0	
						C502_0020 ME50				≤60	90.0	
3.077	477/155	350	480	600	14	C502_0031 ME30	2800	2400	4000	≤38	25.0	21.0
						C502_0031 ME40				≤48	47.0	
						C502_0031 ME50	2500	≤60	76.0	21.0		
3.867	58/15	390	600	750	14	C502_0039 ME30	2800	2400	4000	≤38	20.0	21.0
						C502_0039 ME40				≤48	42.0	
						C502_0039 ME50	2500	≤60	71.0			
4.629	162/35	270	270	340	14	C502_0046 ME20	3100	2700	4500	≤32	12.0	20.0
		400				C502_0046 ME30				≤38	18.0	
		520	700	880		C502_0046 ME40	3000	≤48	40.0	21.0		
						C502_0046 ME50	2500	2500	4000		≤60	69.0
5.850	117/20	440	770	970	14	C502_0059 ME30	3100	2700	4500	≤38	15.0	21.0
		C502_0059 ME40				3000				≤48	37.0	
		C502_0059 ME50				2500	2500	4000	≤60	66.0		
7.763	621/80	320	400	500	14	C502_0078 ME20	3400	3000	5000	≤32	7.8	21.0
		460				C502_0078 ME30				≤38	13.0	
		610	800	1110		C502_0078 ME40	3000	≤48	35.0	21.0		
						C502_0078 ME50	2500	2500	4000		≤60	64.0
8.263	1537/186	800	920	1600	12	C502_0083 ME30	2800	2400	4000	≤38	20.0	23.0
						C502_0083 ME40				≤48	42.0	
						C502_0083 ME50	2500	≤60	71.0			
9.261	3445/372	800	850	1600	12	C502_0093 ME30	2800	2400	4000	≤38	20.0	23.0
						C502_0093 ME40				≤48	42.0	
						C502_0093 ME50	2500	≤60	71.0			
10.38	841/81	800	920	1600	12	C502_0105 ME30	2800	2400	4000	≤38	18.0	23.0
						C502_0105 ME40				≤48	40.0	
						C502_0105 ME50	2500	≤60	69.0			
11.64	1885/162	800	850	1600	12	C502_0115 ME30	2800	2400	4000	≤38	17.0	23.0
						C502_0115 ME40				≤48	39.0	
						C502_0115 ME50	2500	≤60	68.0			

C Series: INLINE — Shaft Output

¹⁾ Maximum torque for continuous input 1500 RPM - horizontal output position.

²⁾ Maximum momentary torque for emergency stops or heavy shock load. (Admissible stops per life of gearhead = 1,000 stops maximum.)

* Motor shaft adapter code (shaft diameter max - mm): ME10 (19), ME20 (32), ME30 (38), ME40 (48), ME50 (60)

C Series: INLINE – Shaft Output

Reducer Ratio (i)		Output Torque			Backlash $\Delta\phi_2$	Part Number (Gearhead + Input)	Max. Input Speed RPM (n1)			Motor Shaft Max ϕ d_{MW}	Input Inertia J_1	Tors. Stiffness C_2
		Nom. ¹⁾ M_{2N}	Accel. M_{2acc}	Peak ²⁾ M_{2NOT}			Continuous		Cyclic			
Nom.	Exact	Nm	Nm	Nm	arcmin		EL 1,2,3,4	EL 5,6	All	mm	kgcm ²	Nm/ arcmin

C5 (continued next page)

12.43	87/7	720	720	900	12	C502_0125 ME20	3100	2700	4500	≤32	10.0	23.0		
						C502_0125 ME30				≤38	16.0			
		800	920	1600		C502_0125 ME40				3000	≤48		38.0	
						C502_0125 ME50				2500	2500		4000	≤60
13.93	195/14		810	1010	12	C502_0140 ME20	3100	2700	4500	≤32	10.0	23.0		
						C502_0140 ME30				≤38	16.0			
		800	850	1600		C502_0140 ME40				3000	≤48		37.0	
						C502_0140 ME50				2500	2500		4000	≤60
15.71	377/24				12	C502_0155 ME30	3100	2700	4500	≤38	14.0	23.0		
						C502_0155 ME40				3000	≤48		36.0	
		800	920	1600		C502_0155 ME50				2500	2500		4000	≤60
17.60	845/48				12	C502_0175 ME30	3100	2700	4500	≤38	14.0	23.0		
						C502_0175 ME40				3000	≤48		36.0	
		800	850	1600		C502_0175 ME50				2500	2500		4000	≤60
20.84	667/32			1330	12	C502_0210 ME20	3400	3000	5000	≤32	7.1	23.0		
						C502_0210 ME30				≤38	13.0			
				1600		C502_0210 ME40				3000	4500		≤48	34.0
						C502_0210 ME50				2500	2500		4000	≤60
23.36	1495/64			1490	12	C502_0230 ME20	3400	3000	5000	≤32	7.1	23.0		
						C502_0230 ME30				≤38	13.0			
				1600		C502_0230 ME40				3000	4500		≤48	34.0
						C502_0230 ME50				2500	2500		4000	≤60
25.07	2407/96			1440	12	C502_0250 ME20	3400	3000	5000	≤32	6.3	23.0		
						C502_0250 ME30				≤38	12.0			
				1600		C502_0250 ME40				3000	4500		≤48	34.0
						C502_0250 ME50				2500	2500		4000	≤60
28.10	5395/192				12	C502_0280 ME20	3400	3000	5000	≤32	6.3	23.0		
						C502_0280 ME30				≤38	12.0			
				1600		C502_0280 ME40				3000	4500		≤48	34.0
						C502_0280 ME50				2500	2500		4000	≤60
31.23	406/13				12	C502_0310 ME20	3400	3000	5000	≤32	5.7	23.0		
				1520		C502_0310 ME30				≤38	11.0			

¹⁾ Maximum torque for continuous input 1500 RPM - horizontal output position.

²⁾ Maximum momentary torque for emergency stops or heavy shock load. (Admissible stops per life of gearhead = 1,000 stops maximum.)

* Motor shaft adapter code (shaft diameter max - mm): ME10 (19), ME20 (32), ME30 (38), ME40 (48), ME50 (60)

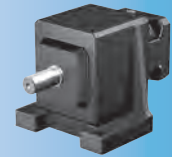

Selection Data

Reducer Ratio (i)		Output Torque			Backlash $\Delta\phi_2$	Part Number (Gearhead + Input)	Max. Input Speed RPM (n1)			Motor Shaft Max ϕ d_{MW}	Input Inertia J_1	Tors. Stiffness C_2
		Nom. ¹⁾ M_{2N}	Accel. M_{2acc}	Peak ²⁾ M_{2NOT}			Continuous	Cyclic				
Nom.	Exact	Nm	Nm	Nm	arcmin		EL 1,2,3,4	EL 5,6	All	mm	kgcm ²	Nm/arcmin

C5 (continued from previous page)

35.00	35/1	800	850	1600	12	C502_0350 ME20	3400	3000	5000	≤32	5.6	23.0
						C502_0350 ME30				≤38	11.0	
41.69	667/16	800	920	1600	12	C502_0420 ME20	3400	3000	5000	≤32	5.0	23.0
						C502_0420 ME30				≤38	10.0	
46.72	1495/32	800	850	1600	12	C502_0470 ME20	3400	3000	5000	≤32	5.0	23.0
						C502_0470 ME30				≤38	10.0	
49.82	1943/39	800	920	1600	12	C502_0500 ME20	3400	3000	5000	≤32	4.8	23.0
						C502_0500 ME30				≤38	10.0	
55.83	335/6	800	850	1600	12	C502_0560 ME20	3400	3000	5000	≤32	4.8	23.0
						C502_0560 ME30				≤38	10.0	
62.43	4495/72	710	860	1080	12	C502_0620 ME20	3400	3000	5000	≤24	3.0	23.0
69.97	10,075/144	800	850	1210	12	C502_0700 ME20	3400	3000	5000	≤24	3.0	23.0
80.60	19,343/240	800	920	1330	12	C503_0810 ME20	3400	3000	5000	≤24	2.9	23.0
90.32	8671/96	800	850	1490	12	C503_0900 ME20	3400	3000	5000	≤24	2.9	23.0
108.6	31,291/288	800	850	1600	12	C503_1090 ME20	3400	3000	5000	≤24	2.8	23.0
135.3	406/3	800	850	1600	12	C503_1350 ME20	3400	3000	5000	≤24	2.8	23.0
180.6	8671/48	800	850	1600	12	C503_1810 ME20	3400	3000	5000	≤24	2.8	23.0
215.9	1943/9	800	850	1600	12	C503_2160 ME20	3400	3000	5000	≤24	2.7	23.0
270.5	58,435/216	800	850	1210	12	C503_2710 ME20	3400	3000	5000	≤24	2.7	23.0

C Series: INLINE — Shaft Output

¹⁾ Maximum torque for continuous input 1500 RPM - horizontal output position.

²⁾ Maximum momentary torque for emergency stops or heavy shock load. (Admissible stops per life of gearhead = 1,000 stops maximum.)

* Motor shaft adapter code (shaft diameter max - mm): ME10 (19), ME20 (32), ME30 (38), ME40 (48), ME50 (60)

C Series: INLINE – Shaft Output

Reducer Ratio (i)		Output Torque			Backlash $\Delta\phi_2$	Part Number (Gearhead + Input)	Max. Input Speed RPM (n1)			Motor Shaft Max ϕ d_{MW}	Input Inertia J_1	Tors. Stiffness C_2
		Nom. ¹⁾ M_{2N}	Accel. M_{2ACC}	Peak ²⁾ M_{2NOT}			Continuous		Cyclic			
Nom.	Exact	Nm	Nm	Nm	arcmin	EL 1,2,3,4	EL 5,6	All	mm	kgcm ²	Nm/ arcmin	

C6 (continued next page)

4.184	2745/656	930	1220	1520	10	C612_0042 ME40	2300	1900	3000	≤48	79.0	70.0	
						C612_0042 ME50				≤60			107.0
5.083	61/12	990	1480	1850	10	C612_0051 ME40	2300	1900	3000	≤48	68.0	71.0	
						C612_0051 ME50				≤60			96.0
5.854	240/41	1040	1380	2130	10	C612_0059 ME40	2300	1900	3000	≤48	74.0	72.0	
						C612_0059 ME50				≤60			102.0
6.518	3233/496	830	1010	1260	10	C612_0065 ME30	2700	2300	3800	≤38	35.0	72.0	
		1070	1610	2370		C612_0065 ME40				≤48			58.0
						C612_0065 ME50				≤60			86.0
7.111	64/9	1110	1380	2590	10	C612_0071 ME40	2300	1900	3000	≤48	64.0	73.0	
						C612_0071 ME50				≤60			92.0
8.190	1769/216	910	1270	1580	10	C612_0082 ME30	2700	2300	3800	≤38	29.0	73.0	
		1160	1650	2900		C612_0082 ME40				≤48			51.0
						C612_0082 ME50				≤60			79.0
9.118	848/93	1160	1380	1770	10	C612_0091 ME30	2700	2300	3800	≤38	33.0	73.0	
		1200	1380	2600		C612_0091 ME40				≤48			56.0
						C612_0091 ME50				≤60			83.0
10.11	3721/368	960	1440	1800	10	C612_0100 ME30	3000	2600	4000	≤38	24.0	73.0	
		1240	1650	2900		C612_0100 ME40				≤48			47.0
						C612_0100 ME50				≤60			75.0
11.46	928/81	1280	1380	2220	10	C612_0115 ME30	2700	2300	3800	≤38	27.0	74.0	
		1300		2600		C612_0115 ME40				≤48			50.0
						C612_0115 ME50				≤60			78.0
12.58	2013/160	1030	1650	2120	10	C612_0125 ME30	3000	2600	4000	≤38	20.0	74.0	
		1340		2900		C612_0125 ME40				≤48			43.0
						C612_0125 ME50				≤60			71.0
14.15	976/69	1300	1380	2520	10	C612_0140 ME30	3000	2600	4000	≤38	23.0	74.0	
				2600		C612_0140 ME40				≤48			46.0
						C612_0140 ME50				≤60			74.0
16.20	1037/64	1090	1650	2290	10	C612_0160 ME30	3200	2900	4500	≤38	17.0	74.0	
				2900		C612_0160 ME40				≤48			39.0
						C612_0160 ME50				≤60			67.0
17.60	88/5	1300	1380	2600	10	C612_0175 ME30	3000	2600	4000	≤38	20.0	74.0	
						C612_0175 ME40				≤48			42.0
						C612_0175 ME50				≤60			70.0
19.61	549/28	1130	1650	2560	10	C612_0195 ME30	3200	2900	4500	≤38	15.0	74.0	
		1450				C612_0195 ME40				≤48			37.0
						C612_0195 ME50				≤60			66.0

¹⁾ Maximum torque for continuous input 1500 RPM - horizontal output position.

²⁾ Maximum momentary torque for emergency stops or heavy shock load. (Admissible stops per life of gearhead = 1,000 stops maximum.)

* Motor shaft adapter code (shaft diameter max - mm): ME10 (19), ME20 (32), ME30 (38), ME40 (48), ME50 (60)



Selection Data

Reducer Ratio (i)		Output Torque			Backlash $\Delta\phi_2$	Part Number (Gearhead + Input)	Max. Input Speed RPM (n1)			Motor Shaft Max ϕ d_{MW}	Input Inertia J_1	Tors. Stiffness C_2
		Nom. ¹⁾ M_{2N}	Accel. M_{2acc}	Peak ²⁾ M_{2NOT}			Continuous		Cyclic			
Nom.	Exact	Nm	Nm	Nm	arcmin		EL 1,2,3,4	EL 5,6	All	mm	kgcm ²	Nm/arcmin

C6 (continued next page)

22.67	68/3	1300	1380	2600	10	C612_0230 ME30	3200	2900	4500	≤38	16.0	74.0
						C612_0230 ME40	3000			≤48	39.0	
						C612_0230 ME50	2500			2500	4000	
24.93	5185/208	1170	1650	2900	10	C612_0250 ME30	3200	2900	4500	≤38	13.0	74.0
		1450				C612_0250 ME40	3000			≤48	35.0	
		C612_0250 ME50				2500	2500			4000	≤60	
27.43	192/7	1300	1380	2600	10	C612_0270 ME30	3200	2900	4500	≤38	15.0	74.0
						C612_0270 ME40	3000			≤48	37.0	
						C612_0270 ME50	2500			2500	4000	
32.41	1037/32	1220	1650	2900	10	C612_0320 ME30	3200	2900	4500	≤38	12.0	74.0
		1450				C612_0320 ME40	3000			≤48	34.0	
		C612_0320 ME50				2500	2500			4000	≤60	
34.87	1360/39	1300	1380	2600	10	C612_0350 ME30	3200	2900	4500	≤38	13.0	74.0
						C612_0350 ME40	3000			≤48	35.0	
						C612_0350 ME50	2500			2500	4000	
39.40	1891/48	1220	1280	1600	10	C612_0390 ME30	3200	2900	4500	≤38	11.0	74.0
45.33	136/3	1300	1380	2600	10	C612_0450 ME30	3200	2900	4500	≤38	12.0	74.0
						C612_0450 ME40	3000			≤48	34.0	
						C612_0450 ME50	2500			2500	4000	
55.11	496/9	1300	1380	2240	10	C612_0550 ME30	3200	2900	4500	≤38	11.0	74.0
68.89	620/9	1300	1380	2360	10	C612_0690 ME30	3200	2900	4500	≤38	10.0	74.0
49.28	31,537/640	1450	1550	1940	10	C613_0490 ME30	3200	2900	4500	≤38	11.0	74.0
63.46	48,739/768	1450	1650	2290	10	C613_0630 ME30	3200	2900	4500	≤38	10.0	74.0
75.81	5307/70	910	910	1140	10	C613_0760 ME20	3200	2900	4500	≤24	3.1	74.0
76.80	8601/112	1450	1650	2560	10	C613_0770 ME30	3200	2900	4500	≤38	10.0	74.0
88.78	799/9	1300	1380	2600	10	C613_0890 ME30	3200	2900	4500	≤38	10.0	74.0
97.63	243,695/2496	1450	1650	2900	10	C613_0980 ME30	3200	2900	4500	≤38	10.0	74.0
106.1	3712/35	1280	1280	1600	10	C613_1060 ME20	3200	2900	4500	≤24	3.0	74.0
107.4	752/7	1300	1380	2600	10	C613_1070 ME30	3200	2900	4500	≤38	10.0	74.0
126.9	48,739/384	1450	1650	2900	10	C613_1270 ME30	3200	2900	4500	≤38	10.0	74.0
134.8	15,776/117	1300	1380	1720	10	C613_1350 ME20	3200	2900	4500	≤24	2.9	74.0
136.6	15,980/117	1300	1380	2600	10	C613_1370 ME30	3200	2900	4500	≤38	10.0	74.0
175.3	7888/45	1300	1380	2010	10	C613_1750 ME20	3200	2900	4500	≤24	2.8	74.0
177.6	1598/9	1300	1380	2600	10	C613_1780 ME30	3200	2900	4500	≤38	10.0	74.0
213.1	28,768/135	1300	1380	2240	10	C613_2130 ME20	3200	2900	4500	≤24	2.8	74.0
266.4	7192/27	1300	1380	2360	10	C613_2660 ME20	3200	2900	4500	≤24	2.8	74.0

C Series: INLINE — Shaft Output

¹⁾ Maximum torque for continuous input 1500 RPM - horizontal output position.

²⁾ Maximum momentary torque for emergency stops or heavy shock load. (Admissible stops per life of gearhead = 1,000 stops maximum.)

* Motor shaft adapter code (shaft diameter max - mm): ME10 (19), ME20 (32), ME30 (38), ME40 (48), ME50 (60)

C Series: INLINE – Shaft Output

Reducer Ratio (i)		Output Torque			Backlash $\Delta\phi_2$	Part Number (Gearhead + Input)	Max. Input Speed RPM (n1)			Motor Shaft Max ϕ d_{MW}	Input Inertia J_1	Tors. Stiffness C_2
		Nom. ¹⁾ M_{2N}	Accel. M_{2ACC}	Peak ²⁾ M_{2NOT}			Continuous		Cyclic			
Nom.	Exact	Nm	Nm	Nm	arcmin	EL 1,2,3,4	EL 5,6	All	mm	kgcm ²	Nm/ arcmin	

C7 (continued next page)

4.259	477/112	1240	1240	1550	10	C712_0043 ME40	2200	1900	2800	≤48	128.0	112.0	
						C712_0043 ME50				≤60			156.0
5.311	1827/344	1550	1550	1930	10	C712_0053 ME40	2200	1900	2800	≤48	103.0	116.0	
						C712_0053 ME50				≤60			131.0
7.357	3480/473	1850	2140	2680	10	C712_0074 ME40	2200	1900	2800	≤48	97.0	119.0	
						C712_0074 ME50				≤60			125.0
8.490	4347/512	1940	2470	3090	10	C712_0085 ME40	2600	2300	3500	≤48	70.0	119.0	
						C712_0085 ME50	2500			≤60			98.0
9.912	4599/464	1180	1540	1920	10	C712_0099 ME30	2900	2600	4000	≤38	41.0	120.0	
		2050	2760	3610		C712_0099 ME40				≤48			64.0
						C712_0099 ME50				2500			2500
11.76	1035/88	2000	2300	4000	10	C712_0120 ME40	2600	2300	3500	≤48	68.0	121.0	
						C712_0120 ME50	2500			≤60			96.0
13.18	4851/368	1250	1820	2270	10	C712_0130 ME30	2900	2600	4000	≤38	31.0	121.0	
		2250	2760	4790		C712_0130 ME40				≤48			54.0
						C712_0130 ME50				2500			2500
13.73	4380/319	1630	2130	2660	10	C712_0135 ME30	2900	2600	4000	≤38	39.0	121.0	
		2000	2300	4000		C712_0135 ME40				≤48			62.0
						C712_0135 ME50				2500			2500
16.73	1071/64	1360	2180	2720	10	C712_0165 ME30	3100	2900	4500	≤38	25.0	121.0	
		2400	2760	4800		C712_0165 ME40	3000			≤48			47.0
						C712_0165 ME50	2500	2500	4000	≤60	75.0	122.0	
18.26	420/23	1730	2300	3150	10	C712_0185 ME30	2900	2600	4000	≤38	30.0	122.0	
		2000	2300	4000		C712_0185 ME40				≤48			53.0
						C712_0185 ME50				2500			2500
20.67	1323/64	1380	2260	2820	10	C712_0210 ME30	3100	2900	4500	≤38	20.0	122.0	
		2400	2760	4800		C712_0210 ME40	3000			≤48			43.0
						C712_0210 ME50	2500	2500	4000	≤60	71.0		
23.18	255/11	1880	2300	3770	10	C712_0230 ME30	3100	2900	4500	≤38	24.0	122.0	
		2000	2300	4000		C712_0230 ME40	3000			≤48			47.0
						C712_0230 ME50	2500			2500			4000
25.31	405/16	1450	2540	3170	10	C712_0250 ME30	3100	2900	4500	≤38	17.0	122.0	
		2400				C712_0250 ME40	3000			≤48			39.0
						C712_0250 ME50	2500	2500	4000	≤60	68.0		

¹⁾ Maximum torque for continuous input 1500 RPM - horizontal output position.

²⁾ Maximum momentary torque for emergency stops or heavy shock load. (Admissible stops per life of gearhead = 1,000 stops maximum.)

* Motor shaft adapter code (shaft diameter max - mm): ME10 (19), ME20 (32), ME30 (38), ME40 (48), ME50 (60)

Selection Data

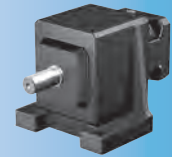

Reducer Ratio (i)		Output Torque			Backlash $\Delta\phi_2$	Part Number (Gearhead + Input)	Max. Input Speed RPM (n1)			Motor Shaft Max ϕ d_{MW}	Input Inertia J_1	Tors. Stiffness C_2
		Nom. ¹⁾ M_{2N}	Accel. M_{2acc}	Peak ²⁾ M_{2NOT}			Continuous		Cyclic			
Nom.	Exact	Nm	Nm	Nm	arcmin		EL 1,2,3,4	EL 5,6	All	mm	kgcm ²	Nm/arcmin

C7 (continued from previous page)

28.64	315/11	1910	2300	3910	10	C712_0290 ME30	3100	2900	4500	≤38	20.0	122.0
		2000		4000		C712_0290 ME40	3000			≤48	43.0	
						C712_0290 ME50	2500			2500	4000	
33.80	2163/64	1490	2760	3710	10	C712_0340 ME30	3100	2900	4500	≤38	14.0	122.0
		2400				C712_0340 ME40	3000			≤48	36.0	
						C712_0340 ME50	2500			2500	4000	
35.07	2700/77	2000	2300	4000	10	C712_0350 ME30	3100	2900	4500	≤38	17.0	122.0
						C712_0350 ME40	3000			≤48	39.0	
						C712_0350 ME50	2500			2500	4000	
41.02	2625/64	1530	2510	4070	10	C712_0410 ME30	3100	2900	4500	≤38	13.0	122.0
		2090				C712_0410 ME40	3000			≤48	35.0	
						C712_0410 ME50	2500			2500	4000	
46.82	515/11	2000	2300	4000	10	C712_0470 ME30	3100	2900	4500	≤38	14.0	122.0
						C712_0470 ME40	3000			≤48	36.0	
						C712_0470 ME50	2500			2500	4000	
56.82	625/11	2000	2300	4000	10	C712_0570 ME30	3100	2900	4500	≤38	13.0	122.0
						C712_0570 ME40	3000			≤48	35.0	
						C712_0570 ME50	2500			2500	4000	
69.55	765/11	2000	2120	2650	10	C712_0700 ME30	3100	2900	4500	≤38	12.0	122.0
50.85	18,711/368	2400	2760	4800	10	C713_0510 ME40	3000	2900	4500	≤48	34.0	122.0
64.55	4131/64	2400	2760	4800	10	C713_0650 ME40	3000	2900	4500	≤48	34.0	122.0
79.73	5103/64	2400	2760	4800	10	C713_0800 ME40	3000	2900	4500	≤48	34.0	122.0
80.97	20,727/256	2220	2260	2820	10	C713_0810 ME30	3100	2900	4500	≤38	11.0	122.0
89.42	6885/77	2000	2300	4000	10	C713_0890 ME40	3000	2900	4500	≤48	34.0	122.0
97.63	10,935/112	2400	2540	3170	10	C713_0980 ME40	3000	2900	4500	≤48	34.0	122.0
99.14	6345/64	2350	2530	3170	10	C713_0990 ME30	3100	2900	4500	≤38	10.0	122.0
110.5	1215/11	2000	2300	4000	10	C713_1100 ME40	3000	2900	4500	≤48	34.0	122.0
130.4	8343/64	2400	2760	3710	10	C713_1300 ME40	3000	2900	4500	≤48	33.0	122.0
132.4	33,887/256	2400	2760	3710	10	C713_1320 ME30	3100	2900	4500	≤38	10.0	122.0
135.3	72,900/539	2000	2300	4000	10	C713_1350 ME40	3000	2900	4500	≤48	34.0	122.0
137.3	10,575/77	2000	2300	4000	10	C713_1370 ME30	3100	2900	4500	≤38	10.0	122.0
180.6	13,905/77	2000	2300	4000	10	C713_1810 ME40	3000	2900	4500	≤48	33.0	122.0
183.4	24,205/132	2000	2300	4000	10	C713_1830 ME30	3100	2900	4500	≤38	10.0	122.0
219.2	16,875/77	2000	2300	4000	10	C713_2190 ME40	3000	2900	4500	≤48	33.0	122.0
222.5	29,375/132	2000	2300	4000	10	C713_2230 ME30	3100	2900	4500	≤38	10.0	122.0

C Series: INLINE — Shaft Output

¹⁾ Maximum torque for continuous input 1500 RPM - horizontal output position.

²⁾ Maximum momentary torque for emergency stops or heavy shock load. (Admissible stops per life of gearhead = 1,000 stops maximum.)

* Motor shaft adapter code (shaft diameter max - mm): ME10 (19), ME20 (32), ME30 (38), ME40 (48), ME50 (60)

C Series: INLINE – Shaft Output

Reducer Ratio (i)		Output Torque			Backlash $\Delta\phi_2$	Part Number (Gearhead + Input)	Max. Input Speed RPM (n1)			Motor Shaft Max ϕ d_{MW}	Input Inertia J_1	Tors. Stiffness C_2
		Nom. ¹⁾ M_{2N}	Accel. M_{2acc}	Peak ²⁾ M_{2NOT}			Continuous		Cyclic			
Nom.	Exact	Nm	Nm	Nm	arcmin	EL 1,2,3,4	EL 5,6	All	mm	kgcm ²	Nm/ arcmin	

C8 (continued next page)

6.670	767/115	1940	1940	2430	10	C812_0067 ME40	2500	2200	3500	≤48	164.0	139.0
						C812_0067 ME50				≤60		
9.043	208/23	2630	2630	3290	10	C812_0090 ME40	2500	2200	3500	≤48	153.0	197.0
						C812_0090 ME50				≤60		
10.15	944/93	2680	2950	3690	10	C812_0100 ME40	2700	2400	3800	≤48	106.0	143.0
		2950				C812_0100 ME50	2500			≤60		
12.75	5546/435	2578	3710	4637	10	C812_0125 ME40	2700	2400	3800	≤48	85.0	144.0
		3284				C812_0125 ME50	2500			≤60		
13.76	1280/93	3600	4010	5010	10	C812_0140 ME40	2700	2400	3800	≤48	101.0	201.0
						C812_0140 ME50	2500			≤60		
17.10	1180/69	3040	4800	6220	10	C812_0170 ME40	2900	2700	4300	≤48	67.0	144.0
		3990				C812_0170 ME50	2500	2500	4000	≤60		
17.29	1504/87	3600	4140	6290	10	C812_0175 ME40	2700	2400	3800	≤48	83.0	202.0
						C812_0175 ME50	2500			≤60		
20.26	6077/300	3140	4800	6760	10	C812_0200 ME40	2900	2700	4300	≤48	59.0	145.0
		4190				C812_0200 ME50	2500	2500	4000	≤60		
23.19	1600/69	3600	4140	7200	10	C812_0230 ME40	2900	2700	4300	≤48	66.0	203.0
						C812_0230 ME50	2500	2500	4000	≤60		
26.06	3127/120	3240	4800	7450	10	C812_0260 ME40	2900	2700	4300	≤48	50.0	145.0
		4200				C812_0260 ME50	2500	2500	4000	≤60		
27.47	412/15	3600	4140	7200	10	C812_0270 ME40	2900	2700	4300	≤48	58.0	203.0
						C812_0270 ME50	2500	2500	4000	≤60		
33.59	2183/65	3370	4800	8400	10	C812_0340 ME40	2900	2700	4300	≤48	44.0	145.0
		4200				C812_0340 ME50	2500	2500	4000	≤60		
35.33	106/3	3600	4140	7200	10	C812_0350 ME40	2900	2700	4300	≤48	50.0	203.0
						C812_0350 ME50	2500	2500	4000	≤60		
39.94	2596/65	3470	3690	4610	10	C812_0400 ME40	2900	2700	4300	≤48	40.0	145.0
		3690				C812_0400 ME50	2500	2500	4000	≤60		
45.54	592/13	3600	4140	7200	10	C812_0460 ME40	2900	2700	4300	≤48	44.0	203.0
						C812_0460 ME50	2500	2500	4000	≤60		
54.15	704/13	3600	4140	6250	10	C812_0540 ME40	2900	2700	4300	≤48	40.0	203.0
						C812_0540 ME50	2500	2500	4000	≤60		
65.96	10,620/161	4190	4800	6220	10	C813_0660 ME40	2900	2700	4300	≤48	35.0	203.0
68.89	620/9	3600	4140	6750	10	C812_0690 ME40	2900	2700	4300	≤48	37.0	203.0
						C812_0690 ME50	2500	2500	4000	≤60		
49.18	49,914/1015	3710	3710	4640	10	C813_0490 ME40	2900	2700	4300	≤48	37.0	203.0

¹⁾ Maximum torque for continuous input 1500 RPM - horizontal output position.

²⁾ Maximum momentary torque for emergency stops or heavy shock load. (Admissible stops per life of gearhead = 1,000 stops maximum.)

* Motor shaft adapter code (shaft diameter max - mm): ME10 (19), ME20 (32), ME30 (38), ME40 (48), ME50 (60)

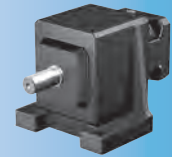

Selection Data

Reducer Ratio (i)		Output Torque			Backlash $\Delta\phi_2$	Part Number (Gearhead + Input)	Max. Input Speed RPM (n1)			Motor Shaft Max ϕ d_{MW}	Input Inertia J_1	Tors. Stiffness C_2
		Nom. ¹⁾ M_{2N}	Accel. M_{2acc}	Peak ²⁾ M_{2NOT}			Continuous		Cyclic			
Nom.	Exact	Nm	Nm	Nm	arcmin		EL 1,2,3,4	EL 5,6	All	mm	kgcm ²	Nm/arcmin

C8 (continued from previous page)

78.13	54,693/700	4200	4800	6760	10	C813_0780 ME40	2900	2700	4300	≤48	35.0	204.0
79.34	285,619/3600	2460	2490	3110	10	C813_0790 ME30	2900	2700	4300	≤38	12.0	203.0
89.44	14,400/161	3600	4140	7200	10	C813_0890 ME40	2900	2700	4300	≤48	35.0	204.0
90.82	18,800/207	2810	2860	3570	10	C813_0910 ME30	2900	2700	4300	≤38	12.0	204.0
100.5	28,143/280	4200	4800	7450	10	C813_1010 ME40	2900	2700	4300	≤48	34.0	204.0
105.9	3708/35	3600	4140	7200	10	C813_1060 ME40	2900	2700	4300	≤48	35.0	204.0
107.6	4841/45	3330	3370	4210	10	C813_1080 ME30	2900	2700	4300	≤38	12.0	204.0
129.5	58,941/455	4200	4800	8400	10	C813_1300 ME40	2900	2700	4300	≤48	34.0	204.0
136.3	954/7	3600	4140	7200	10	C813_1360 ME40	2900	2700	4300	≤48	34.0	204.0
138.4	2491/18	3600	3720	4650	10	C813_1380 ME30	2900	2700	4300	≤38	11.0	204.0
175.6	15,984/91	3600	4140	7200	10	C813_1760 ME40	2900	2700	4300	≤48	34.0	204.0
178.4	6956/39	3600	4140	5250	10	C813_1780 ME30	2900	2700	4300	≤38	11.0	204.0
208.9	19,008/91	3600	4140	6250	10	C813_2090 ME40	2900	2700	4300	≤48	34.0	204.0
212.1	8272/39	3600	4140	6250	10	C813_2120 ME30	2900	2700	4300	≤38	10.0	204.0
265.7	1860/7	3600	4140	6750	10	C813_2660 ME40	2900	2700	4300	≤48	33.0	204.0
269.8	7285/27	3600	4140	6750	10	C813_2700 ME30	2900	2700	4300	≤38	10.0	204.0

C Series: INLINE — Shaft Output

¹⁾ Maximum torque for continuous input 1500 RPM - horizontal output position.

²⁾ Maximum momentary torque for emergency stops or heavy shock load. (Admissible stops per life of gearhead = 1,000 stops maximum.)

* Motor shaft adapter code (shaft diameter max - mm): ME10 (19), ME20 (32), ME30 (38), ME40 (48), ME50 (60)

C Series: INLINE – Shaft Output

Reducer Ratio (i)		Output Torque			Backlash $\Delta\phi_2$	Part Number (Gearhead + Input)	Max. Input Speed RPM (n1)			Motor Shaft Max ϕ d_{MW}	Input Inertia J_1	Tors. Stiffness C_2
		Nom. ¹⁾ M_{2N}	Accel. M_{2acc}	Peak ²⁾ M_{2NOT}			Continuous		Cyclic			
Nom.	Exact	Nm	Nm	Nm	arcmin		EL 1,2,3,4	EL 5,6	All	mm	kgcm ²	Nm/ arcmin

C9

20.15	2257/112	4800	5630	7030	10	C912_0200 ME50	2500	2500	4000	≤60	120.0	260.0
28.63	2405/84	6000	6500	9990	10	C912_0290 ME50	2500	2500	4000	≤60	116.0	391.0
32.13	3599/112	5140	6760	8440	10	C912_0320 ME50	2500	2500	4000	≤60	88.0	261.0
39.30	4087/104	5190	7210	10370	10	C912_0390 ME50	2500	2500	4000	≤60	80.0	261.0
45.66	3835/84	6000	6500	12000	10	C912_0460 ME50	2500	2500	4000	≤60	87.0	392.0
55.83	335/6	6000	6500	12000	10	C912_0560 ME50	2500	2500	4000	≤60	79.0	392.0
69.97	10,075/144	5520	5520	6900	10	C912_0700 ME50	2500	2500	4000	≤60	73.0	392.0
64.59	295,545/4576	7000	8000	12780	10	C913_0650 ME50	2500	2500	4000	≤60	68.0	392.0
77.73	60,939/784	4990	5630	7030	10	C913_0780 ME40	2800	2600	4000	≤48	37.0	392.0
79.06	115,107/1456	7000	8000	14000	10	C913_0790 ME50	2500	2500	4000	≤60	67.0	392.0
91.76	8075/88	6000	6500	12000	10	C913_0920 ME50	2500	2500	4000	≤60	68.0	393.0
99.42	20,679/208	7000	8000	14000	10	C913_0990 ME50	2500	2500	4000	≤60	66.0	393.0
110.4	21,645/196	6000	6500	9990	10	C913_1100 ME40	2800	2600	4000	≤48	37.0	392.0
112.3	3145/28	6000	6500	12000	10	C913_1120 ME50	2500	2500	4000	≤60	67.0	393.0
126.1	183,549/1456	7000	8000	14000	10	C913_1260 ME50	2500	2500	4000	≤60	65.0	393.0
141.3	565/4	6000	6500	12000	10	C913_1410 ME50	2500	2500	4000	≤60	66.0	393.0
176.1	34,515/196	6000	6500	12000	10	C913_1760 ME40	2800	2600	4000	≤48	35.0	393.0
179.1	5015/28	6000	6500	12000	10	C913_1790 ME50	2500	2500	4000	≤60	65.0	393.0
215.4	3015/14	6000	6500	12000	10	C913_2150 ME40	2800	2600	4000	≤48	35.0	393.0

¹⁾ Maximum torque for continuous input 1500 RPM - horizontal output position.

²⁾ Maximum momentary torque for emergency stops or heavy shock load. (Admissible stops per life of gearhead = 1,000 stops maximum.)

* Motor shaft adapter code (shaft diameter max - mm): ME10 (19), ME20 (32), ME30 (38), ME40 (48), ME50 (60)